

**OPERATION
AND
MAINTENANCE
MANUAL
WITH
PARTS LIST**

MODEL: B 2-10
SERIAL No.: 107753 through 151285
MANUAL No.: MB-210-06

****IMPORTANT****

READ AND FOLLOW INSTRUCTIONS GIVEN IN SAFETY AND
OPERATIONS SECTIONS, AND THOSE SECTIONS RELATED TO
YOUR SERVICE AND REPAIR RESPONSIBILITIES.

***TAYLOR-DUNN* MFG. CO.**

Commercial and Industrial Vehicles Since 1949

2114 W. Ball Rd., Anaheim, CA 92804 (714) 956-4040 (fax) (714) 956-0504
Mailing Address: P.O. Box 4240, Anaheim, California 92803



TAYLOR-DUNN[®]
Commercial and Industrial Vehicles Since 1949



**The Best Way To Go About
Your Business**

TABLE of CONTENTS

SECTION 1: INTRODUCTION	3
About This Manual	4
Notational Conventions	4
Vehicle Descriptions	5
Standard Specifications	6
Taking Delivery of Your Vehicle	7
SECTION 2: OPERATING GUIDELINES	9
Safety Rules and Guidelines	10
Driver Training	11
Vehicle Controls	12
Driving	14
Loading/Unloading	14
Parking	14
Towing	14
Storing/Returning The Car to Service	14
SECTION 3: SCHEDULED MAINTENANCE AND SERVICE PROCEDURES	17
Maintenance Guidelines	18
Maintenance Checklist	19
Lubrication Chart	20
Troubleshooting Guide	21
Maintenance Procedures	
Brakes	22
Accelerator System	32
Front Axle	34
Steering	38
Front Suspension	43
Rear Suspension	46
Rear Drive and Differential	49
Drive motor	57
Batteries	60
Tires	62
Electrical System	64
Electrical Troubleshooting	65
Charging System	76
Charger Troubleshooting	76
SECTION 4: ILLUSTRATED PARTS LIST	79
Front Axle	80
Front Suspension	82
Front Shocks	84
Steering	86
Steering Gear	88
Park Brake	90
Deadman Seat Brake	92
Master Cylinder & Brake Linkage	94
Hydraulic Brake Lines	96
Front Brakes	98
Rear Brakes	100
Chargers	102
Motors	104,106
Belt Drive	108

TABLE of CONTENTS

SECTION 4: ILLUSTRATED PARTS LIST (continued)

Power Traction Drive	110
Rear Differential	112
Rear Axle	114
Rear Suspension	116
Rear Tires	118
Control Panel	120
Control Panel-EE	122
Accelerator Module	124
Instrumentation	126
Batteries	128
Decals & Miscellaneous Standard Parts	130
Miscellaneous Standard Parts-Cont'd	132

OPTIONAL PARTS

Reverse Warning/Motion Beeper	134
Hitches	134
Directional Signals	136
Seat Belts	136
Pole Mounted Strobe Light	136
Cowl Mounted Emergency Light	136
Cowl w/Windshield	138
Cab	138
Windshield Wipers	138
Strobe Light On Cab	140
Mirrors, Cowl, Cab, or Door Mounted	140
Mirror, Inside Cab	140
Mirror, Winks, Inside Cab	140
Cab Doors, Naugahyde	142
Cab Doors, Metal	142
Surrey Top Cover	144
Fiberglass Top Cover	144
Fixed 2nd Seat	146
Deck, Fixed 2nd Seat	146
Deck Cover, Diamond Plate, Fixed 2nd Seat	146
Fixed 3rd Seat	146
Deck Cover, Diamond Plate, 2 Piece, Standard Bed	148
Side Panels, 12"	148
Foldaway 2nd Seat	150
Deckboard, Foldaway 2nd Seat	150
Deck Cover, Diamond Plate, Foldaway 2nd Seat	150
Deckboard, Lockable, 2 Piece	152
Box, Double Doors, Side & Rear Windows	154
Tool Box Doors, Side	156
Tool Box Doors, Rear	156
Stake Sides, Standard Bed	158
Stake Sides, Fixed 2nd Seat	160
Stake Sides, Foldaway 2nd Seat	162
Nurse's Seat, Black Cushions	164
Deck, Galvanized, Ambulance	164
Ambulance Safety Panels	164

INTRODUCTION



About This Manual

This manual provides you with information you need to safely operate and maintain this vehicle.

We assume that those who will perform maintenance or repair operations are trained vehicle service technicians capable of performing minor and major repairs and qualified to use the tools required.

We also assume that they have or will attend a training program designed to familiarize them with the safe operation and use of this particular vehicle.

This manual contains the following major sections:

Section 1: Introduction

Contains information about how to use this manual, a description of the B2-10, how to do an incoming inspection and vehicle specifications.

Section 2: Vehicle Operation

Provides safety rules and guidelines describes the driver training program and explains the operation of each control on the B2-10.

Section 3: Maintenance and Service Procedures

Contains a scheduled maintenance checklist lubrication diagram troubleshooting guide recommended spare parts list, and detailed maintenance procedures.

Also contains service procedures in for each assembly found in the B2-10. Each major heading contains procedures organized in logical order.

Section 4: Illustrated Parts

Includes an illustration and parts list for each assembly that has replaceable parts for the B2-10.

Notational Conventions

The following types of notations are used throughout this manual:

▲ WARNING

A warning indicates a potentially hazardous situation which, if not avoided, could result in serious injury or worse. Be sure you exercise special care and follow any instructions provided in a warning message.

▲ CAUTION

A caution indicates a potentially hazardous situation which calls attention to unsafe practices, or if not avoided, may result in minor or moderate injury. Be sure you exercise special care and follow any instructions provided in a caution message.



A note provides additional information about a subject.

Vehicle Description

This manual applies to vehicles with serial numbers starting at 107753.

The B2-10 is designed to be driven on smooth surfaces in and around industrial plants, nurseries, institutions, motels, mobile home parks and resorts.

This vehicle is not designed to be driven on public highways. It is not designed to go in excess of 15 mph, whether on a level or a downhill surface. Driving at a speed higher than 15 mph may result in steering difficulty, motor damage, and/or loss of control. It is not designed to be towed in excess of 5 mph.

The B2-10 can handle a total payload (incl. cargo, optional equipment, and driver) of up to 2400 lbs. Various options are available to enable you to customize the vehicle to suit your particular needs. Consult your Taylor-Dunn® salesperson or representative for current options.

This vehicle conforms to requirements for Type E or Type EE (optional) vehicles as described in O.S.H.A. Standard Section 1910.178 (Powered Industrial Trucks) and with all applicable portions of the American National Standard for Personnel and Burden Carriers (ANSI B56.8).

The model and serial number for this vehicle are imprinted on a decal located on the top of the right front wheel well, under the passenger seat. The serial number is stamped in the center park brake mounting plate, between the seats, and can be seen by looking between the seats behind the park brake lever.

NOTE *Your vehicle may have special modifications and options which are not covered in this manual. If the information you need is not in this manual, please contact your Taylor-Dunn® salesperson or representative.*

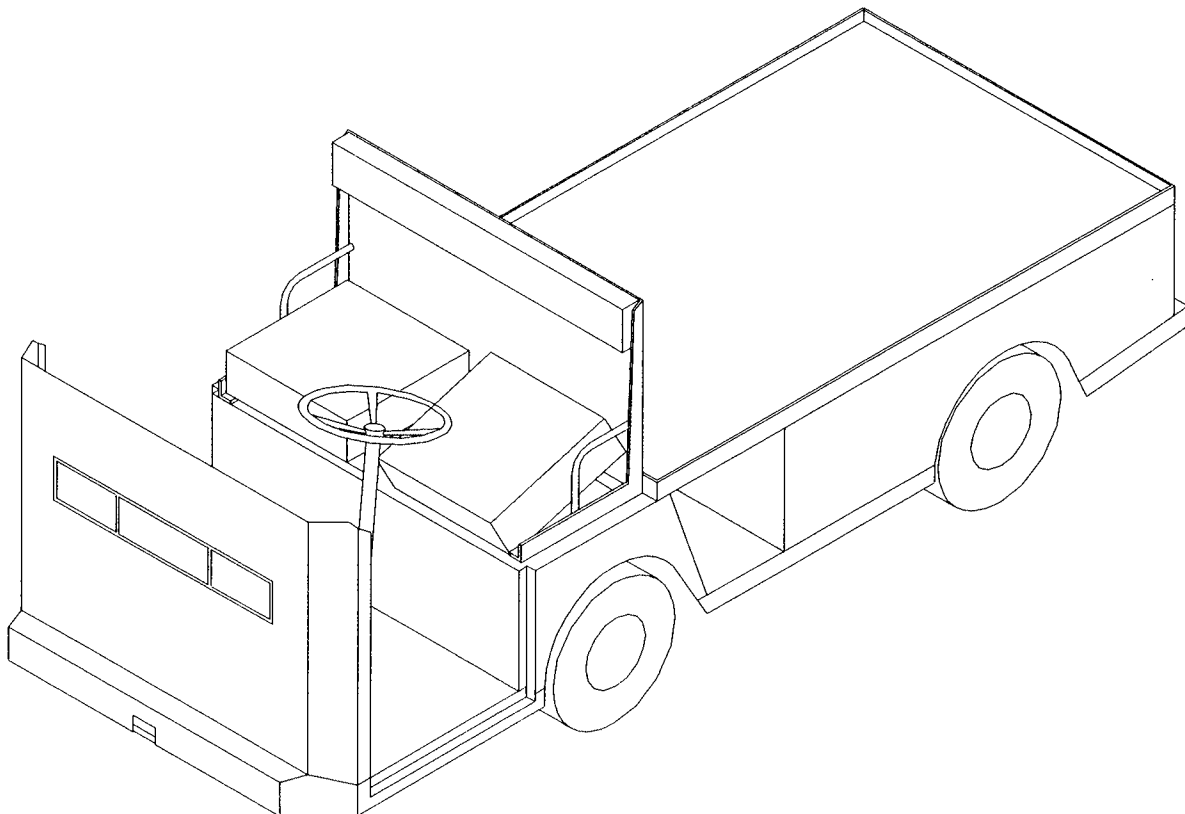

Standard Specifications

ITEM	SPECIFICATION
Standard Dimensions	302L x 114W x 122H (centimeters)
	119L x 45W x 48H (inches)
	Bed Size: 74 x 44-3/4 (inches)
Unit Weight (including batteries)	459 kg
	1013 lbs
Turning Radius	317 centimeters
	125 inches
Transmission	Belt Drive 12:1 reduction
Brakes	Rear Hydraulic Discs, Hand Operated Park Brake
Motor	DC series wound 36V, 6 hp @ 1,400 rpm
Tires	Pneumatic 5.70 x 8, Load Range B
Tire Pressure	50 psi maximum
Maximum Load	2,400 lbs (including driver and optional equipment)
Batteries	6 volt, 217 amp hour, lead acid (6 ea)

Taking Delivery of Your Vehicle

THIS VEHICLE SHOULD BE INSPECTED IMMEDIATELY AFTER DELIVERY. Use the following guidelines to make sure there are no obvious problems.

Inspecting the Vehicle

Examine the contents of all packages and accessories that may have come in separate packages with this vehicle. Make sure everything listed on the packing slip is there. Nothing should look broken or damaged.

Examine any visible wiring for obvious signs of damage. Check that all connections are secure.

Check that battery connections are tight and all cells are filled.

Inspect the tires for obvious wear or damage. Check the tire pressure. Make sure that all wheel lugs are secure.

Check the body, seats, windshield, trim, and other external parts for obvious damage.

Checking the Controls

Operate each of the following controls before turning on the key switch:

- Accelerator pedal
- Brake pedal
- Forward - reverse selector lever
- Parking brake
- Steering wheel
- Horn
- Lights

Each control should operate smoothly and easily without sticking or requiring undue effort.

What To Do If You Find A Problem

If you find a problem with this vehicle you must immediately file a claim with the carrier. The claim must be filed within 48 hours of receiving this vehicle. Forward a copy of the damage claim to your Taylor-Dunn® dealer.

⚠ WARNING

Do not repair modify or adjust any part of this vehicle unless you are authorized to do so. Incorrect repairs may result in injury to yourself and others and cause the invalidation of your warranty.



The Best Way To Go About Your Business

OPERATING GUIDELINES



Safety Rules and Guidelines

▲WARNING

Do not weld, cut, or in any way modify the frame of this vehicle.

Modifications to the frame may compromise the integrity and strength of the original design. This may cause structural failure and/or loss of control, resulting in serious injury.

Modification of the frame structure of this vehicle is strictly prohibited without prior written authorization of Taylor-Dunn Mfg. Inc.

It is the responsibility of the owner of this vehicle to assure that the operator understands the various controls and operating characteristics of this vehicle and obeys the following safety rules and guidelines (extracted from the American National Standards Institute Personnel and Burden Carriers ANSI B56.8).

This vehicle is designed to be driven over smooth surfaces in and around places such as warehouses, nurseries, motels, parks, and resorts. Before you drive this vehicle please observe the following safety rules and guidelines:

▲WARNING

This vehicle is not designed to be driven on public highways. The drive is built to order. It is available in speeds up to 15 mph. This is the speed at which the vehicle travels on a level surface with no load. Do not exceed this speed. Exceeding this speed may result in steering difficulty, motor damage, and/or loss of control. The vehicle should not be towed at more than 5 mph.

▲WARNING

Always use Taylor-Dunn® replacement parts when repairing or replacing damaged parts on your vehicle. Incorrect or inferior parts may result in injury to yourself and others and cause the invalidation of your warranty.

- Do not drive this vehicle unless you are a qualified and trained operator.
- Keep all body parts (head, arms, legs) inside this vehicle while it is moving.
- Drive slowly when making a turn especially if the ground is wet slippery or when driving on an incline.
- This vehicle may overturn easily if turned sharply when driving at high speeds, especially when on an incline.
- Drive only on level surfaces or on surfaces having an incline of no more than 10% (5.6 degrees.).
- Do not drive over loose objects, holes or bumps.
- Observe all traffic regulations and speed limits.
- Keep to the right under normal conditions.
- Maintain a safe distance from all objects.
- Keep the vehicle under control at all times.
- Yield right of way to pedestrians, ambulances, fire trucks, or other vehicles in emergency situations.
- Do not overtake another vehicle at intersections, blind spots, or other dangerous locations.
- Keep a clear view ahead at all times.

Driver Training Program

The owner of this vehicle shall conduct an Operator Training program for all those who will be operating this vehicle. The training program shall not be condensed for those claiming to have previous vehicle operation experience. Successful completion of the Operator Training program shall be required for all personnel who operate this vehicle.

The Operator Training program shall include the following:

- Operation of this vehicle under circumstances normally associated with your particular environment.
- Emphasis on the safety of cargo and personnel.
- All safety rules contained within this manual.
- Proper operation of all vehicle controls.
- A vehicle operation and driving test.

Driver Qualifications.

Only those who have successfully completed the Operator Training program are authorized to drive this vehicle. Operators must possess the visual auditory physical and mental ability to safely operate this vehicle as specified in the American National Standards Institute Controlled Personnel and Burden Carrier ANSI B56.8.

The following are minimum requirements necessary to qualify as an operator of this vehicle:

- Demonstrate a working knowledge of each control.
- Understand all safety rules and guidelines as presented in this manual.
- Know how to properly load and unload cargo.
- Know how to properly park this vehicle.
- Recognize an improperly maintained vehicle.
- Demonstrate ability to handle this vehicle in all conditions.

Vehicle Controls

The following describes the use of each control on this vehicle. Refer to Figure 2-1.



Some controls are optional equipment and may not be installed on this vehicle.

Key Switch

A key switch, located on the right side of the instrument console, starts the vehicle. Rotate the key clockwise to turn the vehicle on, counterclockwise to turn the vehicle off.

▲WARNING

The key switch should be in the off position whenever the driver is off of the vehicle.

This switch is also designed to secure and disable the vehicle. You can remove the key **ONLY** when the key switch is in the OFF position.

Seat Interlock Switch

A switch, located under the driver's seat, disables the vehicle when the driver leaves the seat. The driver must be seated for the vehicle to operate. This is an added safety feature and should never be bypassed.

Forward/Off/Reverse Switch

The forward/off/reverse rocker switch, located on the right side of the instrument panel, determines the direction of travel (forward or reverse) of the vehicle. Push the top of the switch to make the vehicle go forward. Push the bottom of the switch to go in reverse. Position the switch in the center for off.

▲CAUTION

DO NOT SHIFT from forward to reverse or vice-versa while the vehicle is in motion. Make sure the vehicle is completely stopped before shifting.

▲WARNING

The shift switch has a center off position. The shift switch should be in the off position with the park brake set whenever the operator leaves the driver's seat.

Accelerator Pedal

The accelerator pedal, located in the driver's area, to the right of the brake pedal, controls the speed of the vehicle, and is designed for right foot operation. It operates the same way as the accelerator in an automobile. Depress the pedal to increase the vehicle's speed, release the pedal to stop increasing the speed.

Use the brake pedal to slow the vehicle on down grades.

▲CAUTION

DO NOT use the accelerator to keep the vehicle from rolling on a grade. The brake should always be used to stop or hold the vehicle on a grade. Using the accelerator will result in motor damage.

Steering

The B2-10 steering is a automotive type steering system. Turn the steering wheel clockwise to turn to the right, and turn the steering wheel counterclockwise to turn to the left.

Foot Brake Pedal

The foot brake pedal, located to the right of the steering column, is for operation with the right foot only. Apply pressure to the brake pedal to slow the vehicle down. The brake pedal slows the vehicle according to the amount of pressure you apply. Removing your foot from the pedal releases the braking action.

Park Brake Lever

The park brake is actuated with a hand lever, which is located between the driver and passenger seats. To set the park brake, pull the lever up until it locks. To release the park brake, pull up, push the release button, and lower the handle.

⚠ CAUTION

Do not operate the vehicle with the parking brake applied. Severe motor or control damage will result.

Horn button

The horn button is located on the dash shelf, to the right of the instrument console. Depress the button to sound the horn and release the button to turn it off.

Headlight switch

The headlight switch is located on the left side of the instrument panel, and toggles the headlights on and off.

Hour Meter (optional)

The hour meter is located on the instrument panel. This tracks the number of hours the vehicle has been in operation.

Battery Status Indicator

The battery status indicator is located on the instrument panel. The normal operating range is in the green zone. The vehicle needs charging if it is in the yellow zone to the left. If it is in the red zone to the left the vehicle should be taken out of service immediately to be charged.

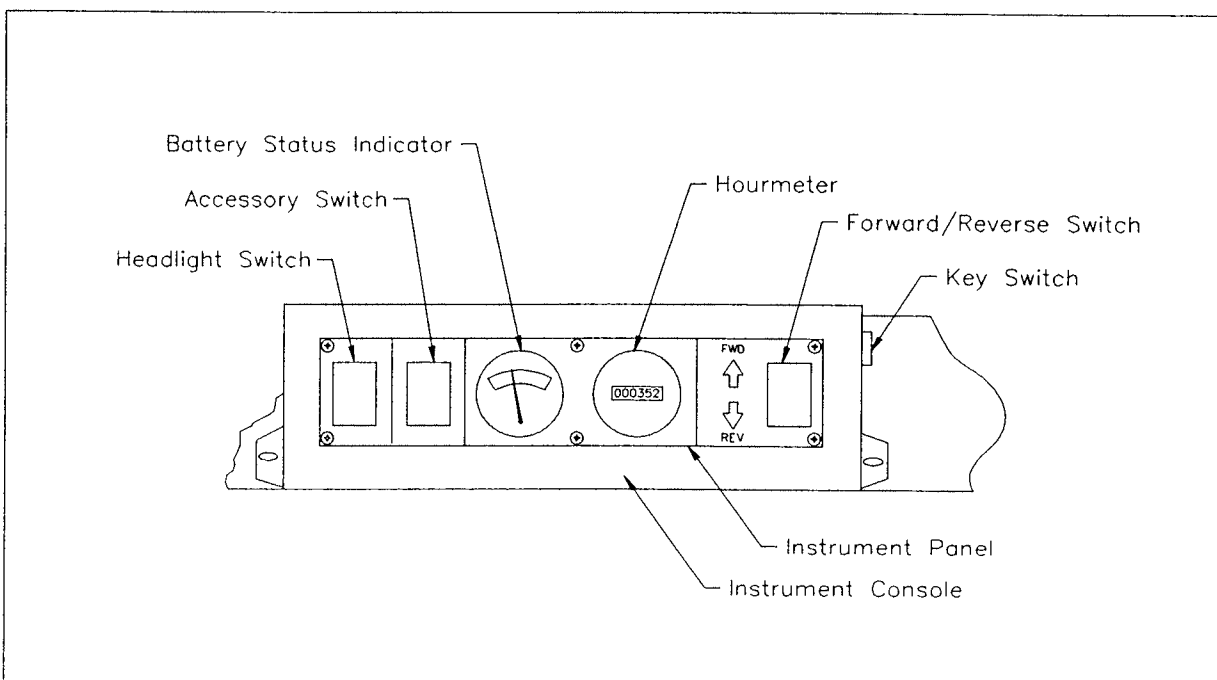

Figure 2-1

Driving

- Slow down and sound the horn when approaching a corner or other blind intersection.
- No horseplay or dangerous driving.
- Do not drive this vehicle in hazardous areas unless this vehicle is approved and labeled for such operation.
- Immediately report any accident or vehicle problem to your supervisor.

Loading and Unloading

- Do not load cargo that can easily fall off this vehicle.
- Do not exceed the cargo load capacity of this vehicle.
- Do not carry more than the maximum number of passengers allowed for this vehicle.
- Be extra careful when handling cargo that is longer, wider or higher than this vehicle.

Parking

- Set the parking brake and place the forward/off/reverse lever in the off position before leaving the vehicle.
- If you will be away from this vehicle turn off the key switch, remove the key and take the key with you.
- If you park this vehicle on an incline block the wheels.
- Do not block fire aisles, fire equipment or stairways.

Towing

- To tow this vehicle attach a tow strap to the front of the frame and place the forward/off/reverse shift lever in the off position.
- Use another driver to steer this vehicle while it is being towed; be sure the driver uses the brakes when the towing vehicle slows or stops.

▲WARNING

Do not exceed 5 MPH or carry any passengers while towing this vehicle.

Storing and Returning to Service

- Do not store batteries in a discharged condition. Fill, charge and clean batteries fully before putting in storage
- Lube all grease fittings.
- Spray all exposed metal surfaces, except brake surfaces, with a light oil.
- Clean and dry all exposed electrical connections.
- Inflate tires to proper pressure and then block them off the ground.
- If stored for a prolonged period the batteries should be charged as follows;

Storage Temperature	Charge
Below 40°F	Every 6 months
40° - 60°F	Every 2 months
Above 60°F	Once a month

Returning to Service

- Check state of charge of batteries and charge if necessary.
- Perform **ALL** maintenance checks in the periodic check list in section 3.
- Test drive before putting into normal service.

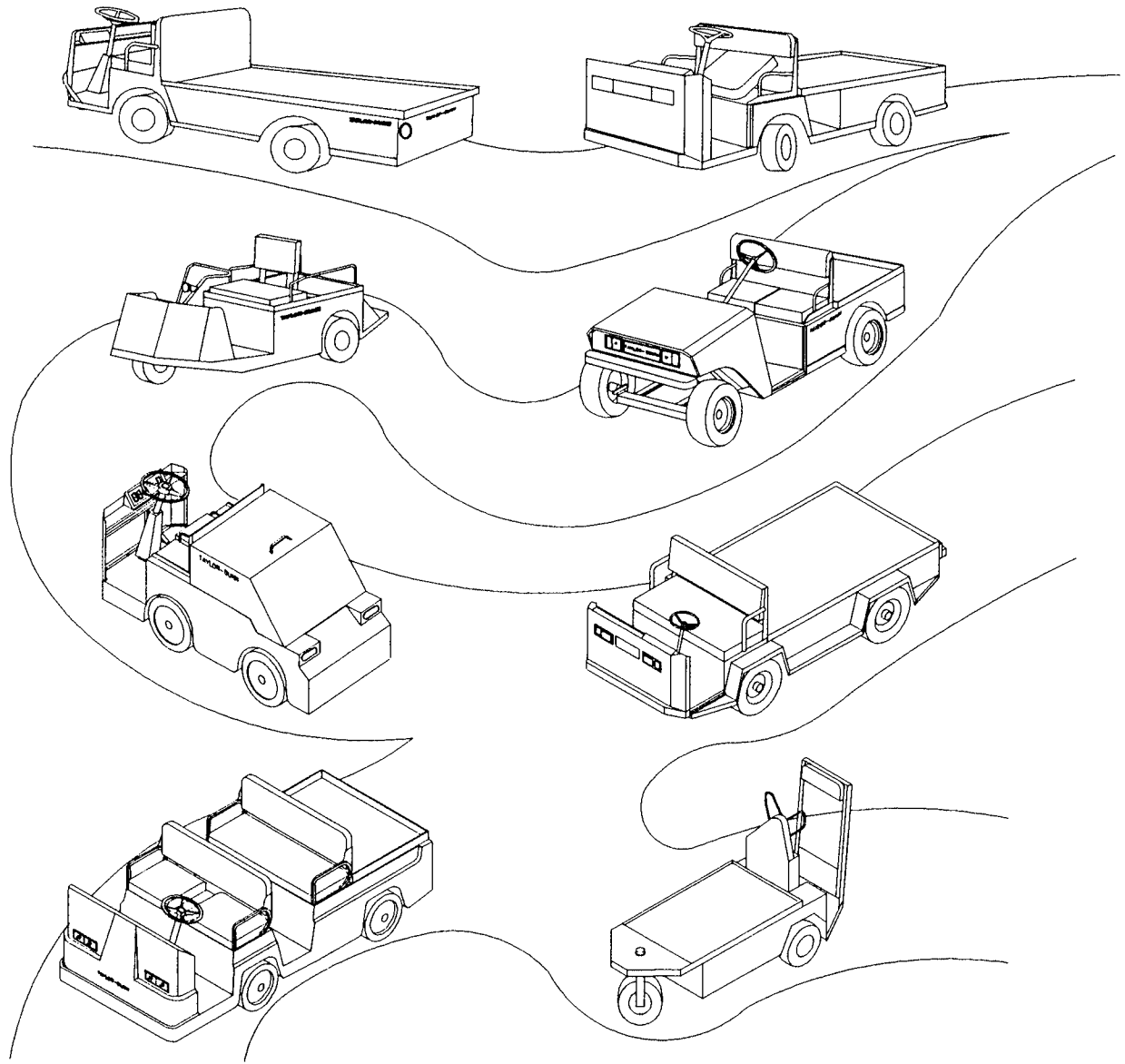

**You're in great company
with Taylor-Dunn®**

**SCHEDULED MAINTENANCE
AND
SERVICE PROCEDURES**



SECTION 3

This section explains how to perform the scheduled maintenance procedures. Use the Maintenance Checklist to determine how often you should perform each procedure. Vehicle maintenance or repairs should only be performed by a qualified mechanic.

This section contains the following:

- Maintenance guidelines.
- Maintenance checklist.
- Lubrication chart.
- Troubleshooting guide.
- Detailed maintenance procedures.

Maintenance Guidelines

- Allow only qualified and authorized personnel to maintain, repair, adjust, and inspect the vehicle.
- Before starting any repairs or maintenance immobilize the vehicle by turning the key switch off, removing the key and setting the park brake.
- Disconnect both of the main battery leads before working on or disconnecting any electrical component or wire.
- Block the chassis with jack stands before working under a raised vehicle.
- Conduct vehicle performance checks in an authorized area where safe clearance exists.

▲ CAUTION

Always raise the drive wheels off of the ground when testing the electrical system

- Before starting the vehicle follow the recommended safety procedures in Section 2, "Vehicle Operation".
- Avoid fire hazards and have fire protection equipment present in the work area. Do not use an open flame to check level or leakage of battery electrolyte. Do not use open pans of fuel or flammable fluids for cleaning parts.
- Ventilate the work area properly.
- Regularly inspect and maintain in a safe working condition: brakes, steering mechanisms, speed and directional control mechanisms, warning devices, lights, governors, guards and safety devices.
- Inspect and maintain battery limit switches, protective devices, electrical conductors and connections in conformance with Taylor-Dunn®'s recommended procedures.
- Keep the vehicle in clean condition to minimize fire hazards and facilitate detection of loose or defective parts.

▲ WARNING *Always use Taylor-Dunn® replacement parts when repairing or replacing damaged parts on your vehicle. Incorrect or inferior parts may result in injury to yourself and others and cause the invalidation of your warranty.*

PERIODIC MAINTENANCE CHECKLIST					
Maintenance Item	Weekly (20 hrs)	Monthly (80 hrs)	Quarterly (250 hrs)	Semi-annually (500 hrs)	Annually (1000 hrs)
Check tire pressure	X				
Check and fill batteries (use distilled water only)	X				
Check foot brake system		X			
Check brake linkage		X			
Check steering bearings for play		X			
Lubricate at all grease fittings			X		
Lubricate moving parts which do not have grease fittings (use all purpose oil)			X		
Clean and tighten all wire connections			X		
Wash batteries with water (use soda if necessary)			X		
Check brake lining for wear, replace as needed				X	
Check front wheel bearings for play, adjust as needed				X	
Check differential oil				X	
Change differential oil					X
Check nuts and bolts for looseness					X
Clean and re-grease front wheel bearings					X
Check motor brushes					X

Lubrication Chart

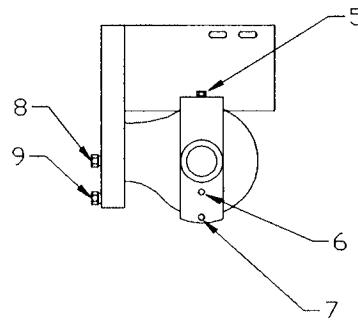
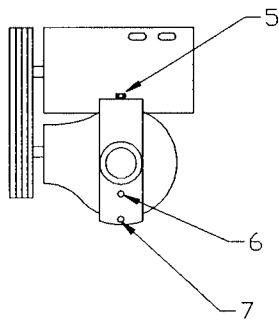
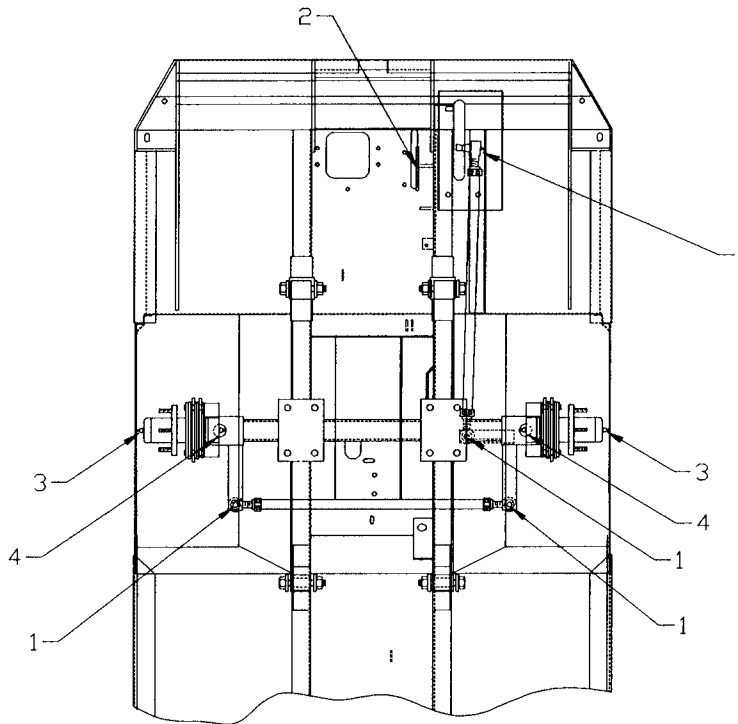

Item No.	Description	Locations	Lubricant Type
1	Steering Ball Joints	4	General Purpose Grease
2	Brake Pedal Linkage	1	General Purpose Grease
3	Front Wheel Bearings	2	Wheel Bearing Grease
4	King Pin	2	General Purpose Grease
5	Differential Fill Plug	1	SAE 140 API GL-5 hypoid gear oil- 2-1/4 qts
6	Differential Level Plug	1	
7	Differential Drain Plug	1	
8	Chain Case Fill Plug	1	SAE 140 API GL-5 hypoid gear oil-1 pint
9	Chain Case Drain Plug	1	

Troubleshooting Guide

SYMPTOM	PROBABLE CAUSE*
Steering Pulls in One Direction	Front End Out of Alignment
	Low Tire Pressure
Hard Steering	Dry Lube Points in Steering Linkage
	Damaged King Pin/Ball Joint
	Low Tire Pressure
Excessive Steering Play	Worn Ball Joints
	Mis-adjusted or Worn Steering Gear
	Loose Steering Linkage
Lack of Power or Slow Operation	Dragging Brake
	Dragging Park Brake
	Damaged Speed Control
	Low Batteries
	Worn Drive Gears
Erratic Power or No Power	Damaged Speed Control
	Loose Wire Connection(s)
	Damaged Motor/ Worn Motor Brushes
	Batteries Discharged or Damaged
Abnormal Noise	Worn Drive Gears or Bearings
	Worn Axle Bearing (front or rear)
	Worn Motor Bearings
	Drive Chain Out of Adjustment
	Loose Wheel Lug Nuts
Oil Leak in Rear Wheel Bearing Area	Wheel Bearing and/or Gasket Failed
	Drive Overfilled
Brake Pedal Soft or Spongy	Air in Brake Lines
	Worn Master Cylinder
Brake Pedal Low	Worn Brake Lining (1/16" wear limit)
	Brake Fluid Low
	Brakes Out of Adjustment
Braking Power Low	Worn Brake Lining (1/16" wear limit)
	Brake Shoes/Pads Contaminated With Fluid
	Brake Pedal Linkage Binding
	Brakes Out of Adjustment
	Air in Brake Lines
*Probable causes are to be used as a guide only. They list some of the probable causes, but are not limited to these causes.	

Brake System

BRAKE LINKAGE

The brake system consists of standard rear hydraulic brakes, and optional front hydraulic brakes. These brakes are not adjustable and require only periodic inspection to ensure that they are in good operating condition, or to replace brake pads. There is adjustment in the linkage from the master cylinder to the brake pedal.

Brake Adjustment or Replacement

If the brake pedal travels to the floorboard and does not have full braking power, either the master cylinder is out of fluid, or the pedal linkage is out of adjustment. Refer to figure 3-1

To adjust the brake pedal linkage:

- Place blocks under the wheels to prevent vehicle movement.

- Disconnect the main positive and negative at the batteries.
- Loosen the jam nut on the push rod.
- Rotate the push rod until the rod is contacts the master cylinder plunger, then back off 1/8".
- Tighten the jam nut from the push rod to the brake rod.

To replace the brake pedal or linkage:

- Remove the return spring. Replace as necessary.
- Loosen the jam nut on the push rod.
- Remove the clevis pin at the brake pedal.
- Remove the brake rod and push rod. Replace as necessary.
- Remove the locknut from the brake pedal mount.

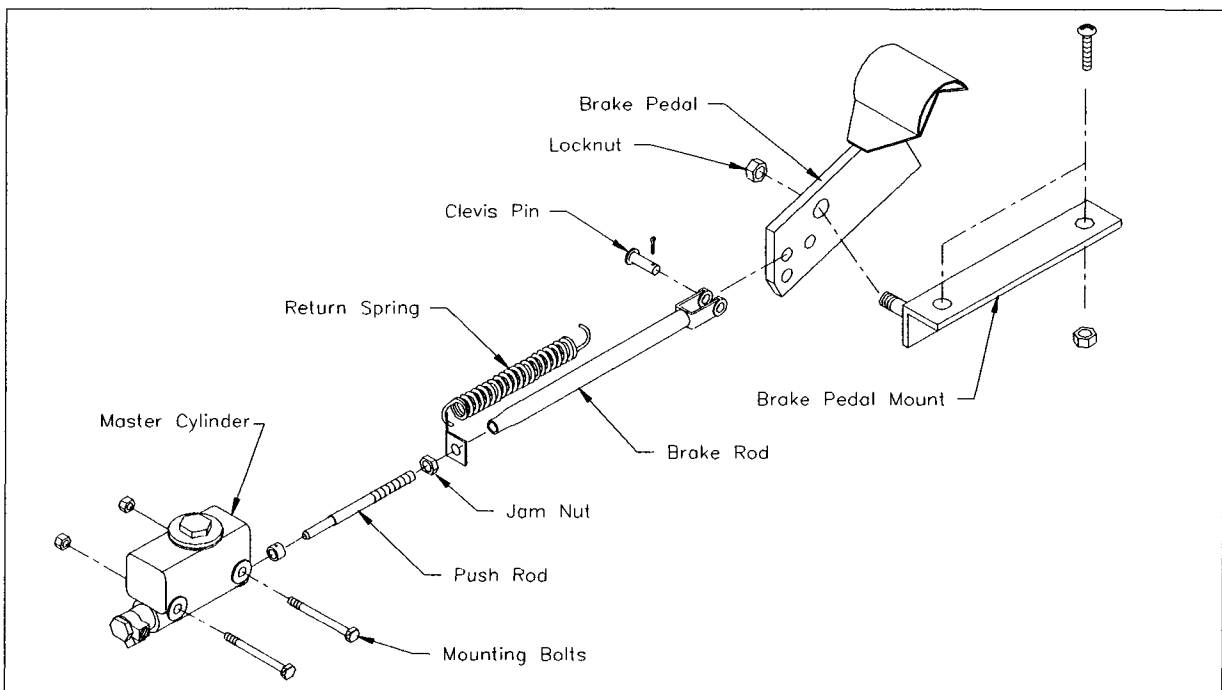

Figure 3-1

- Remove the screws holding the brake pedal mount to the floorboard.
- Remove and replace the brake pedal as necessary.
- Install brake pedal by reversing these procedures. **Always use new cotter pins** (see WARNING!).
- Reinstall the master cylinder by reversing the previous procedures.
- Bleed the brakes to remove air from the system. Use only DOT 5 brake fluid.

▲ WARNING

Always use new cotter pins. Cotter pins used more than once are weakened and may break, resulting in linkage and brake failure.

MASTER CYLINDER

The brake fluid level in the master cylinder should be checked periodically. The proper level of fluid is 1/4" from the top of the chamber. Use only DOT 5 brake fluid.

If the master cylinder is not functioning properly, use the following procedure to remove it.

To remove the master cylinder:

- Place blocks under the wheels to prevent vehicle movement.
- Disconnect the main positive and negative at the batteries.
- Loosen and remove the brake line from the master cylinder. Use a pan to catch any brake fluid which may spill from the brake line and master cylinder.
- Loosen and remove the master cylinder mounting bolts and remove the master cylinder.
- Repair or replace the master cylinder as necessary. See the Illustrated Parts List for replacement parts.

Bleeding The Brakes

If a brake line has been disconnected, or the master cylinder has been removed, the entire hydraulic system must be bled to remove any air from the system. The best way to bleed the brakes is to have one person at the brake pedal, and another person opening and closing the bleeder valve.

To bleed the brake system:

- Add DOT 5 brake fluid to the master cylinder.
- Apply pressure to the brake pedal and pump once or twice for maximum pedal height.
- Loosen one bleeder valve located on the hydraulic brake body at the wheel farthest from the master cylinder. Use a pan to catch the excess brake fluid.
- Depress the brake pedal fully and close the bleeder valve at the bottom of the pedal stroke.
- Repeat the brake pedal stroke until a steady stream of brake fluid flows from the bleeder valve, approximately four strokes.

NOTE *Do not let the fluid level in the master cylinder get too low, as air may enter the brake lines. Keep the level high by constantly adding fluid.*

- Repeat the bleeding process for each wheel having a hydraulic brake.

- Replace the brake pads and reassemble the brake to the retainer bracket (see figure 3-2).

⚠ WARNING

Always use new locknuts. Locknuts become less effective if used more than once.

If the locknuts holding the brake to the drive come loose, serious injury may occur.

- Install new grade 8 locknuts and brake mounting bolts.
- Tighten the bolts to 11 ft-lbs.
- Test the brakes to ensure proper installation and braking.

Hydraulic Brake Body

Use the following procedure to remove and repair the hydraulic brake body for any wheel that has a hydraulic brake.

To repair the brake body:

- Follow the procedure to replace the rear brake pads. If a front brake body (optional) must be repaired, use the same procedure, but raise the front of the vehicle and remove the front wheel.
- Remove the brake hose from the brake body. Use a pan to catch brake fluid.
- Carefully remove the two pistons, rubber boots, and o-rings from the brake body. The pistons are brittle and may chip or break easily.
- Clean and dry the brake body completely. Be sure no contaminants are left in the brake body.

- Inspect the interior of the brake body. If any damage or wear is found, the body must be replaced.
- Replace all damaged parts and reassemble the brake body using clean DOT 5 brake fluid as a lubricant.

NOTE Use tool #41-350-13 to install the rubber boots, see figure 3-3.

- Reconnect the brake hose using thread sealant, and install the brake body to the retainer bracket using new grade 8 locknuts and bolts.

⚠ WARNING

Always use new locknuts. Locknuts become less effective if used more than once.

If the locknuts holding the brake to the drive come loose, serious injury may occur.

- Tighten the bolts to 11 ft-lbs.
- Bleed the brake. Refer to Bleeding The Brakes procedure.
- Test the brakes to ensure proper installation and braking.

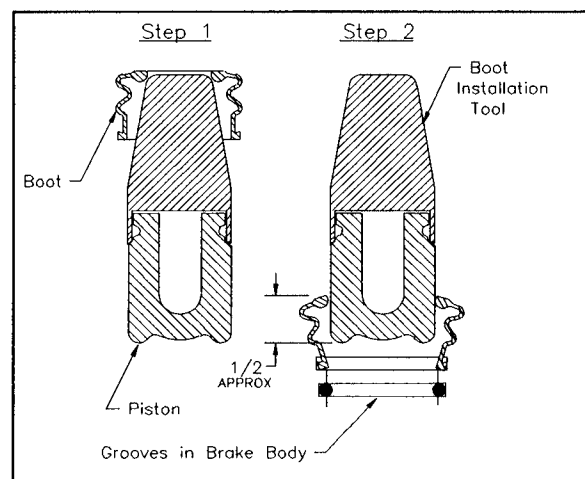

Figure 3-3

SECTION 3

FRONT BRAKES (optional)

If your vehicle is equipped with front hydraulic brakes, they should be periodically inspected for any possible leaks and to check the wear of the brake pads.

The front brake rotors are an integral part of each front hub. If the rotors are damaged or worn, the hub must be replaced.

Front Brake Pads

To remove and replace the front brake pads:

- Place blocks under the rear wheels to prevent vehicle movement.
- Disconnect the main positive and negative at the batteries.
- Raise the front of the vehicle and support with jack stands.

WARNING

Always use a lifting strap, hoist, and jack stands, of adequate capacity to lift and support the vehicle.

Failure to use lifting and support devices of rated load capacity may result in serious injury.

- Remove the front wheels.
- Remove the two 1/4" brake body bolts (see figure 3-4).

NOTE *Do not let the brake body hang by the brake hose. Support the brake body to prevent damage to the hose.*

- Inspect the spacers for wear and replace as necessary.
- Replace the spacer bushings in the axle retainer bracket.

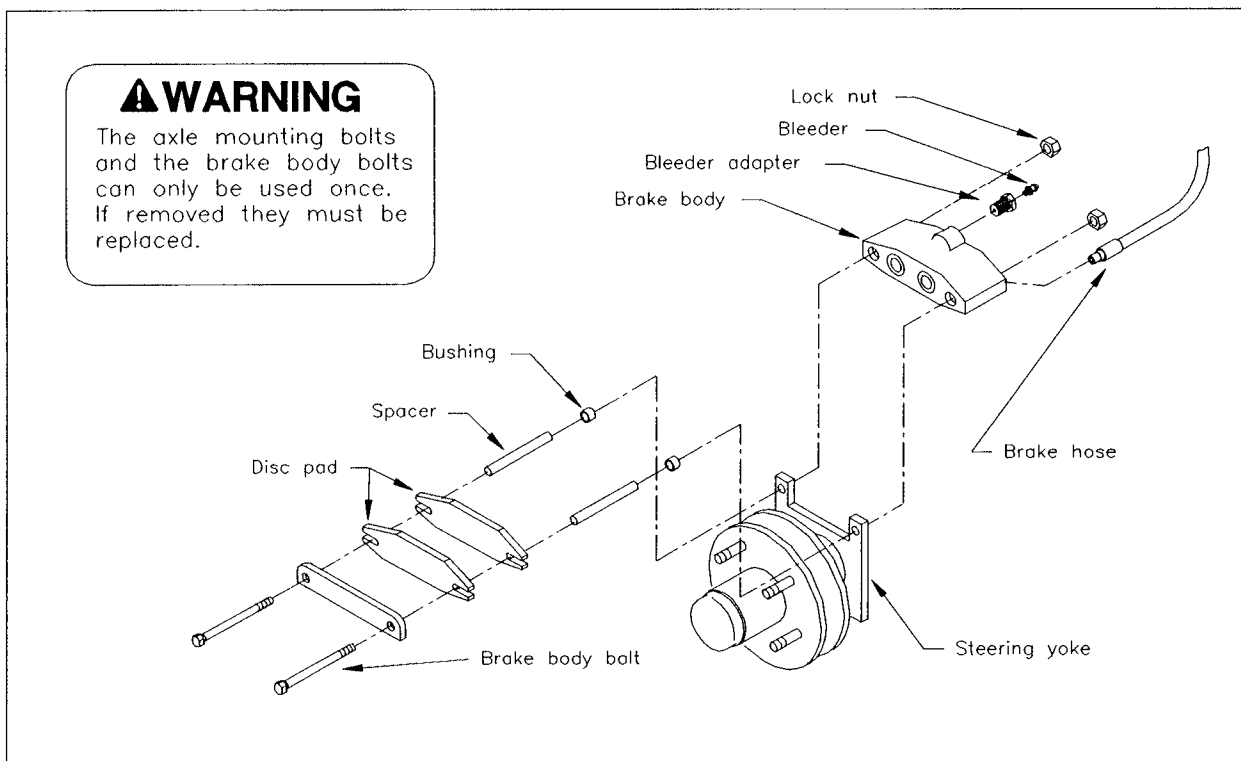

Figure 3-4

- Replace the brake pads and reassemble the brake to the retainer bracket (see figure 3-2).

⚠ WARNING

Always use new locknuts. Locknuts become less effective if used more than once.

If the locknuts holding the brake to the drive come loose, serious injury may occur.

- Install new grade 8 locknuts and brake mounting bolts.
- Tighten the bolts to 11 ft-lbs.
- Test the brakes to ensure proper installation and braking.

PARKING BRAKE

The park brake lever activates the rear brakes through a bar connecting to a cross shaft, which pulls a brake rod connected to each brake caliper.

Park Brake Adjustment

As the brake pads wear, the park brake lever will gain more travel. Proper adjustment for the park brake lever is so that when the lever is pulled up, it clicks on to the second or third ratchet stop.

To properly adjust the park brake lever:

- Place blocks under the rear wheels to prevent vehicle movement.
- Disconnect the main positive and negative at the batteries.
- Loosen the jam nut at the clevis connected to the park brake lever.
- With the park brake lever lowered, position the clevis pin in the cross shaft tabs so that it hits the rear edge of the slot in the brake bar. The cross shaft tabs

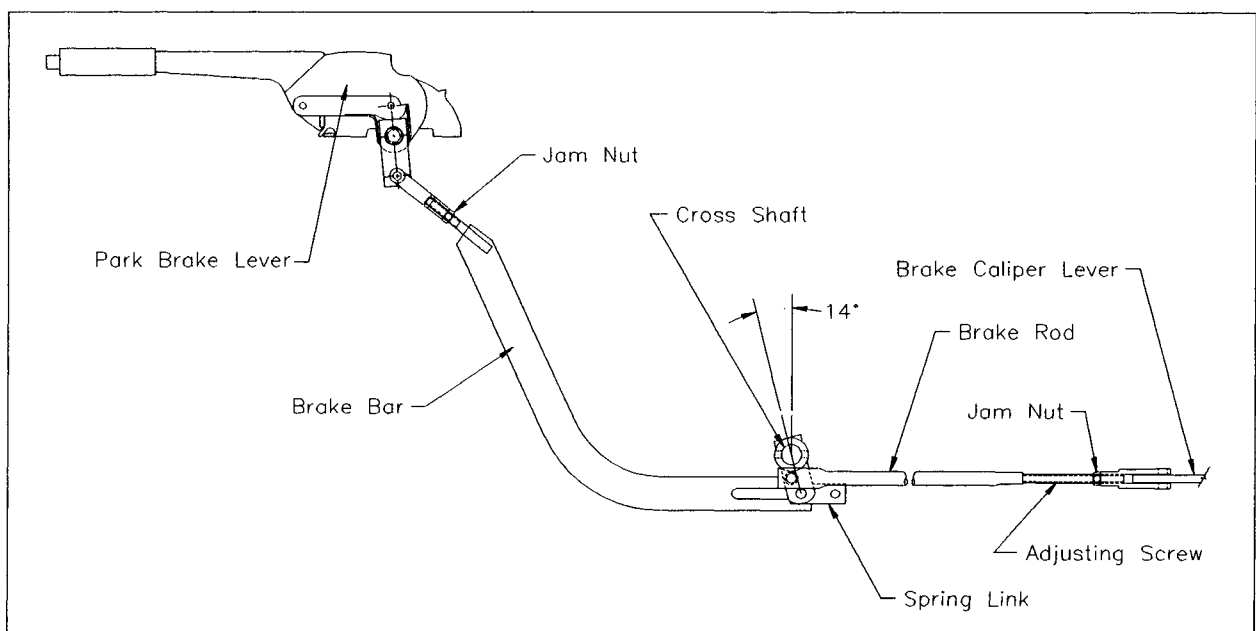

Figure 3-5

SECTION 3

should be 14° to the rear of center (see figure 3-5). Adjust the clevis at the park brake lever arm, if necessary.

- Tighten the jam nut at the clevis.
- Loosen the jam nut at the clevis connected to the brake caliper lever.
- Turn the adjusting screw until the brake pads are slightly engaged and there is no play. Back off the adjusting screw until the park brake lever engages its ratchet two or three stops.

Park Brake Replacement

To replace any part of the park brake linkage or the park brake lever:

- Disconnect the brake rod from the cross shaft and from the caliper lever.
- Remove, replace, and reinstall the return spring as necessary.
- Remove the clevis pins from the brake bar clevis and the cross shaft, and remove the brake bar.
- Replace the brake bar if necessary.
- Remove the park brake lever mounting bolts.
- Remove the park brake lever and replace as necessary.
- Adjust the linkage as described in the 'Park Brake Adjustment' procedure.

▲WARNING

Always use new cotter pins. Old cotter pins may be weak or partially broken and may fall out, which could result in park brake failure, causing serious injury

DEAD MAN SEAT BRAKE (optional)

The dead man seat brake incorporates a park brake and a seat interlock switch, to disconnect the key switch circuit and set the park brake whenever the driver is not seated in the driver's seat.

▲WARNING

Never stand up while the vehicle is in motion. If the driver stands up, the dead man seat brake will engage, which could result in serious injuries.

Deadman Seat Linkage Replacement & Adjustment

The deadman seat linkage is set at the factory and should not require adjustment. However, if the seat brake link has been replaced, the linkage will need to be adjusted.

To replace and adjust the linkage use the following procedure and refer to figure 3-7:

- Loosen the jam nut on the seat brake link.
- Remove the clevis pin from the clevis on the seat brake link.
- Remove the clevis pin holding the seat brake link to the cross shaft and remove the seat brake link.
- If any of the seat returns springs need replacing, remove the spring(s) and install the new spring(s). Leave the springs disconnected from the seat frame.
- If the brake push rod needs to be replaced, remove the clevis pin holding it to the seat frame, remove, and install the new brake push rod.

- If the seat frame itself must be replaced, disconnect all springs and push rods by removing all clevis pins, and remove the seat frame by removing the clevis pins holding it to the vehicle frame.
- Remove the seat cushion from the seat frame, install the new seat frame to the seat cushion, and reinstall the seat frame to the vehicle frame.
- After replacing any damaged parts, adjust the park brake as described in 'Park Brake Adjustment'.
- With the seat frame in the lowered and flat position, rotate the clevis on the seat brake link so that the hole is in line with the hole in the seat link arm.
- Install the return springs to the seat frame.
- Reinstall the clevis pin to the seat brake link and the seat link arm. Use new cotter pins.

⚠ WARNING

Always use new cotter pins. Old cotter pins may be weak or partially broken and may fall out, which could result in park brake failure, causing serious injury

Seat Shock Replacement

The dead man seat brake also has a shock absorber which is mounted from the vehicle frame to the seat frame.

To replace the seat shock, use the following procedure and refer to figure 3-8:

- Disconnect all springs and linkages to the seat frame.
- Remove the lower shock mounting bolt and nut.
- Remove the upper shock mounting bolt and nut, and remove the shock.
- Install the new shock by reversing the procedure above.

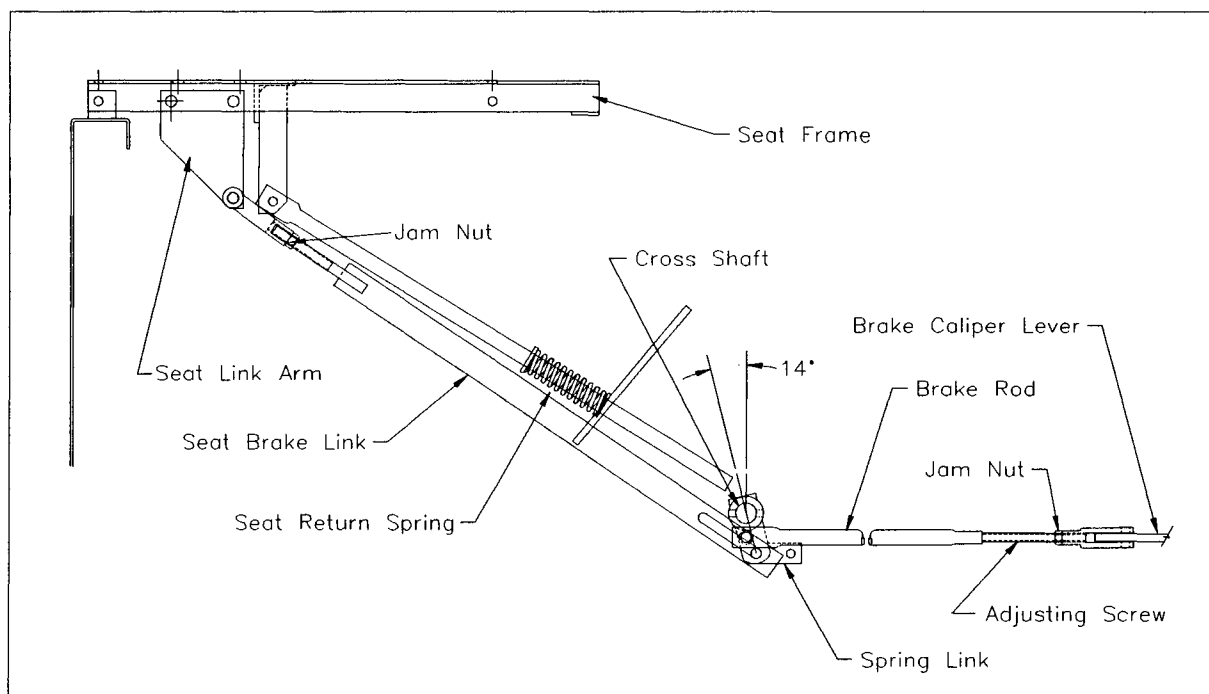

Figure 3-7

SECTION 3

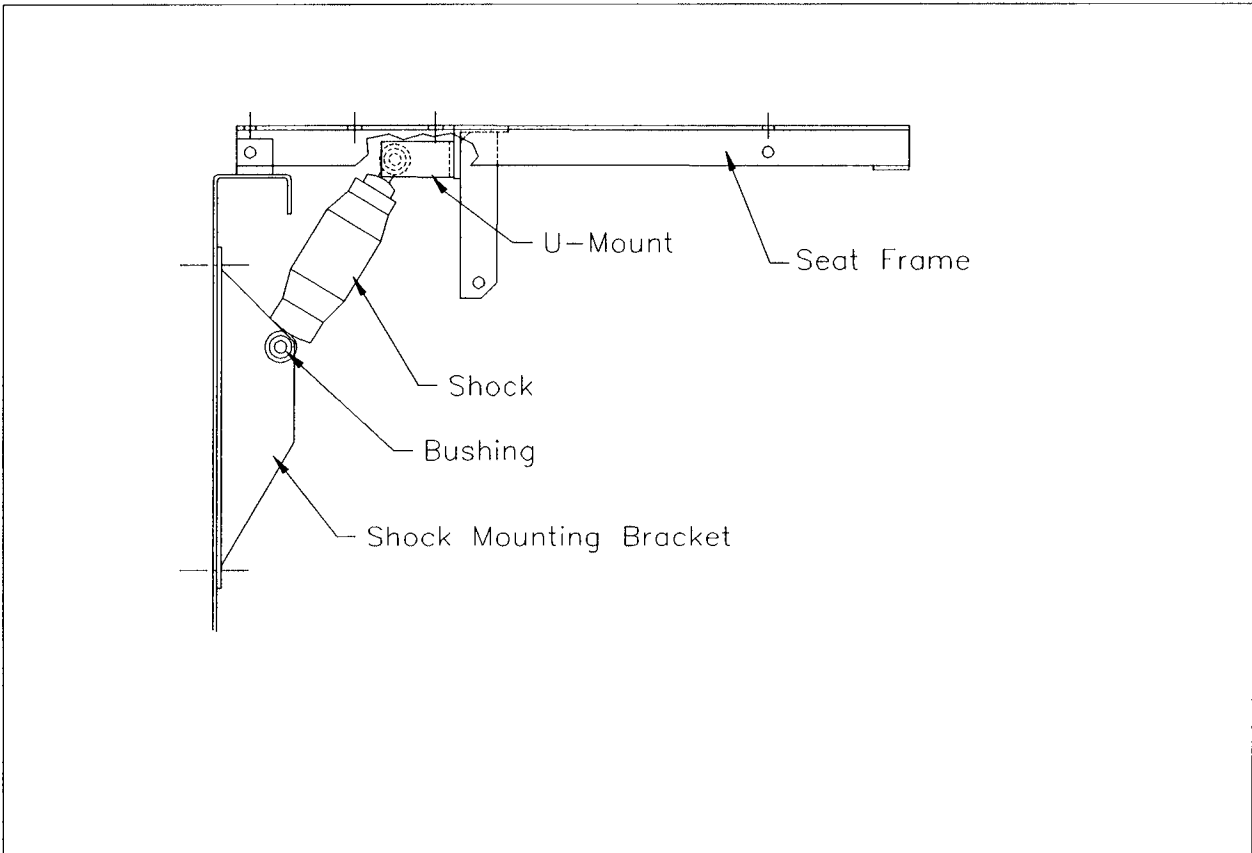

Figure 3-8

Hydraulic Brake Lines

If any of the hydraulic brake lines become damaged, use the following procedure to remove and replace them, and refer to figure 3-9.

- Install the new brake line.
 - Bleed the brakes as described in the 'Bleeding The Brakes' procedure.
-
- Place blocks under the rear wheels to prevent vehicle movement.
 - Disconnect the main positive and negative at the batteries.
 - Loosen the hydraulic fitting on one end of the brake line to be replaced. Use a pan to catch the brake fluid.
 - Loosen the hydraulic fitting on the other end of the brake line to be replaced. Use a second pan to catch the brake fluid.

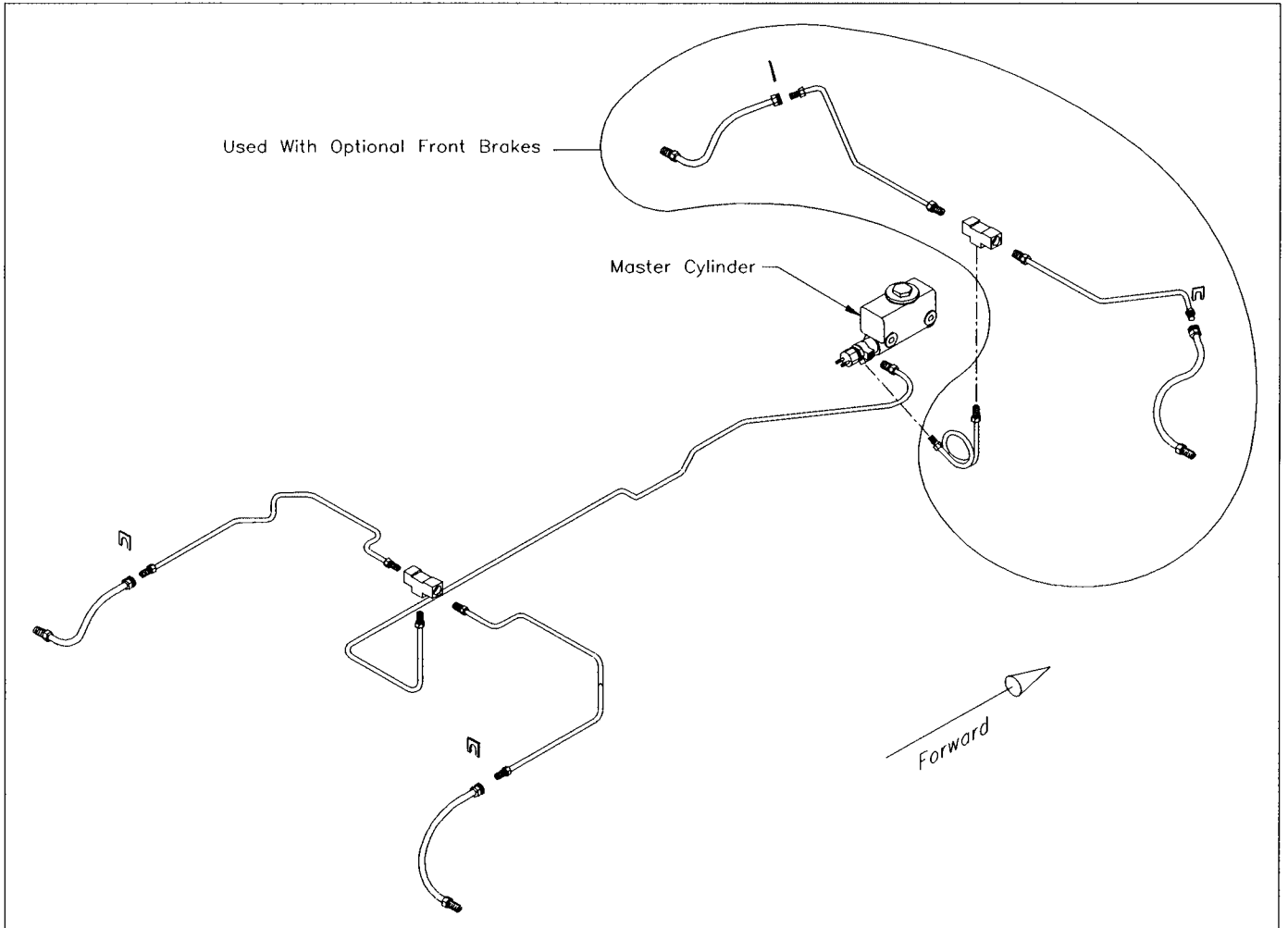

Figure 3-9

Accelerator System

The accelerator system consists of the accelerator pedal and accelerator module. The accelerator module connects to the main wire harness through an quick disconnect plug. For testing the acclerator module, refer to 'Electrical Troubleshooting' in the Electrical System section.

Accelerator Module Replacement

To remove or replace the accelerator pedal or accelerator module, use the following procedure and refer to figure 3-10.

- Place blocks under the rear wheels to prevent vehicle movement.
- Disconnect the main positive and negative at the batteries.
- Remove the bolts holding the pedal mount to the accelerator module arm and replace the pedal or pedal mount if damaged or bent.

- Disconnect the plug in the wire harness from the module.
- Remove the bolts holding the accelerator module to the floorboard and module mounting plate.
- Repair or replace the accelerator module as necessary.
- Reinstall the module to the floorboard and mounting plate.
- Reinstall the pedal and pedal mount to the module.
- Reconnect the plug to the wire harness.
- Test drive the vehicle.

Accelerator Module Return Spring

The accelerator module lever arm is spring loaded to return the pedal to its original position. The return spring, located in the module around the lever arm shaft, is replaceable.

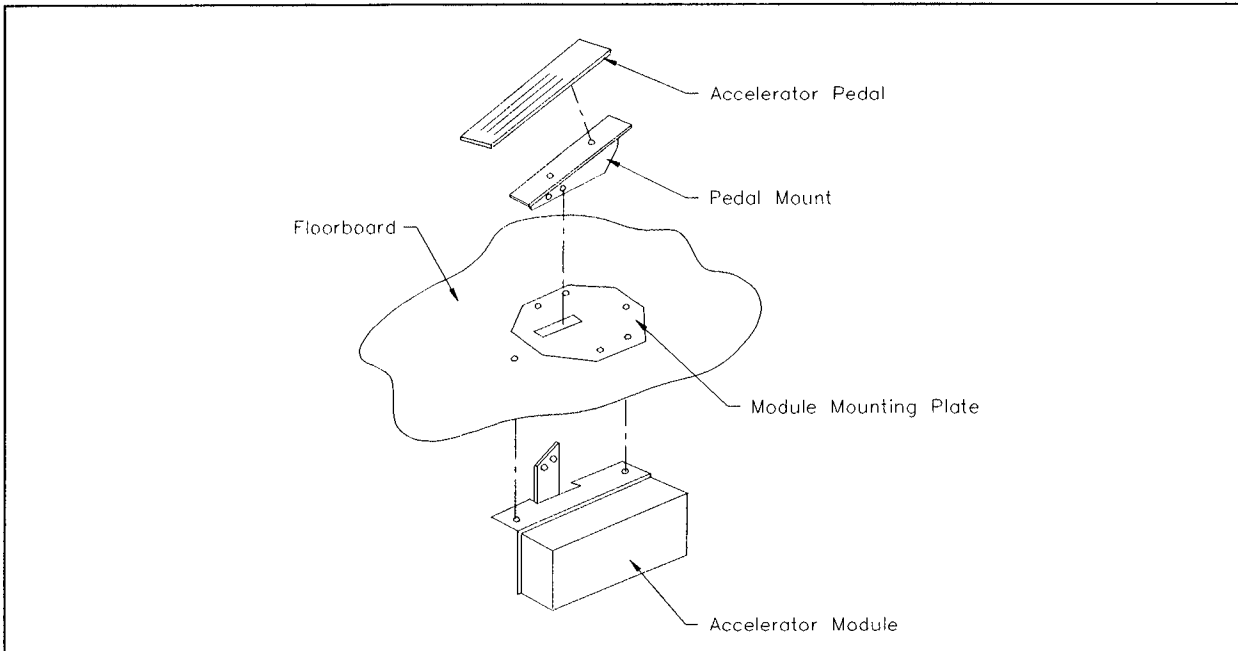

Figure 3-10

Use the following procedure to replace the lever return spring and refer to figure 3-11.

- Remove the accelerator module as described in the 'Accelerator Module Replacement' procedure.
- Remove the accelerator module cover by removing the four screws.
- Remove the circlip holding the lever shaft to the module.
- Slide the shaft and spring out of the module as shown by arrow in figure 3-11.
- Install new spring, placing the shorter spring end, through the washer, and into the module.
- Insert the lever shaft into the module, and insert the longer spring end into the lever.
- Rotate and push the lever into position. Tap the lever if necessary, to allow the circlip to be installed.
- Install the circlip and install the module cover.
- Reinstall the module into the vehicle as described in the 'Accelerator Module Replacement' procedure.

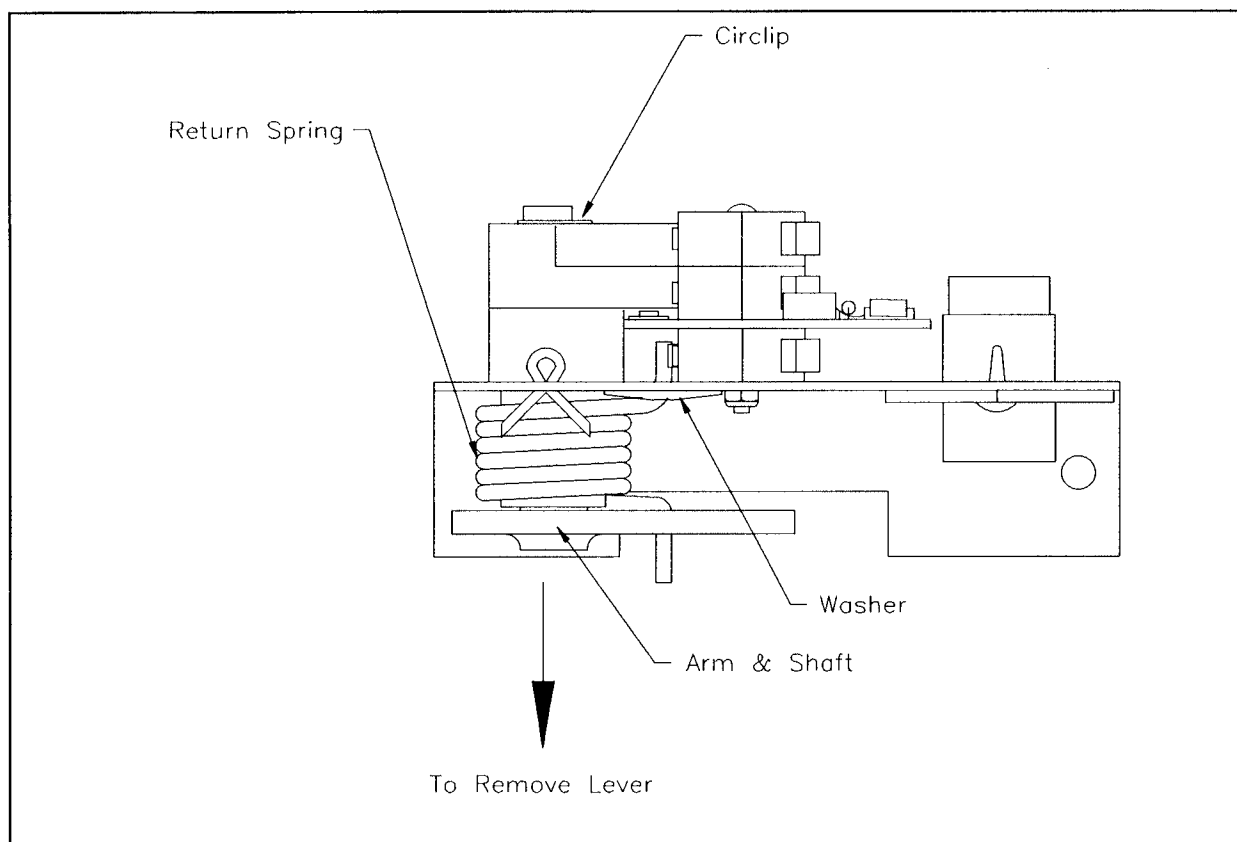

Figure 3-11

Front Axle

The standard front axle consists of a welded tubular steel axle, two yokes, two king pins, and two hubs with bearings. Disc brakes are optional.

Front Axle Replacement

If the front axle or leaf springs are bent or damaged, the axle must be removed and the damaged parts replaced.

Use the following procedure to remove the front axle and springs Refer to figure 3-12.

- Place blocks under the rear wheels to prevent vehicle movement.
- Disconnect the main positive and negative at the batteries.
- Raise the front end of the vehicle and support with jack stands.

▲WARNING

Always use a lifting strap, hoist, and jack stands, of adequate capacity to lift and support the vehicle.

Failure to use lifting and support devices of rated load capacity may result in serious injury.

- Remove the front wheels.
- If the front axle is equipped with hydraulic brakes, disconnect the brake hoses from the brake body. Use a pan to catch any brake fluid.
- Remove the hydraulic brakes as described in the Front Brakes section.
- Remove the hub dust caps and remove the spindle nuts.

- Remove the hubs and bearings, being careful not to let the bearings fall to the ground.
- Remove the drag link and steering adjustment sleeve.
- Remove the leaf spring rear mounting bolts, be careful not to let the axle pivot and drop suddenly.

▲CAUTION

Support the axle and leaf springs when removing the spring mounting bolts, as the axle will pivot and drop suddenly.

- With the axle properly supported, remove the leaf spring front mounting bolts.
- Remove the axle and leaf springs from the vehicle.
- If the leaf spring need to be replaced, refer to the Suspension Removal and Replacement procedure.
- Remove the nuts from the king pins, and remove the king pins. The king pins will need to be tapped out of the yoke from the bottom. Be careful to support the yokes when the king pins are removed.
- Inspect the bushings in the axle sleeves for wear and replace as necessary. Clean all surfaces of the bushings and king pins. The bushings will need to be pressed into place.

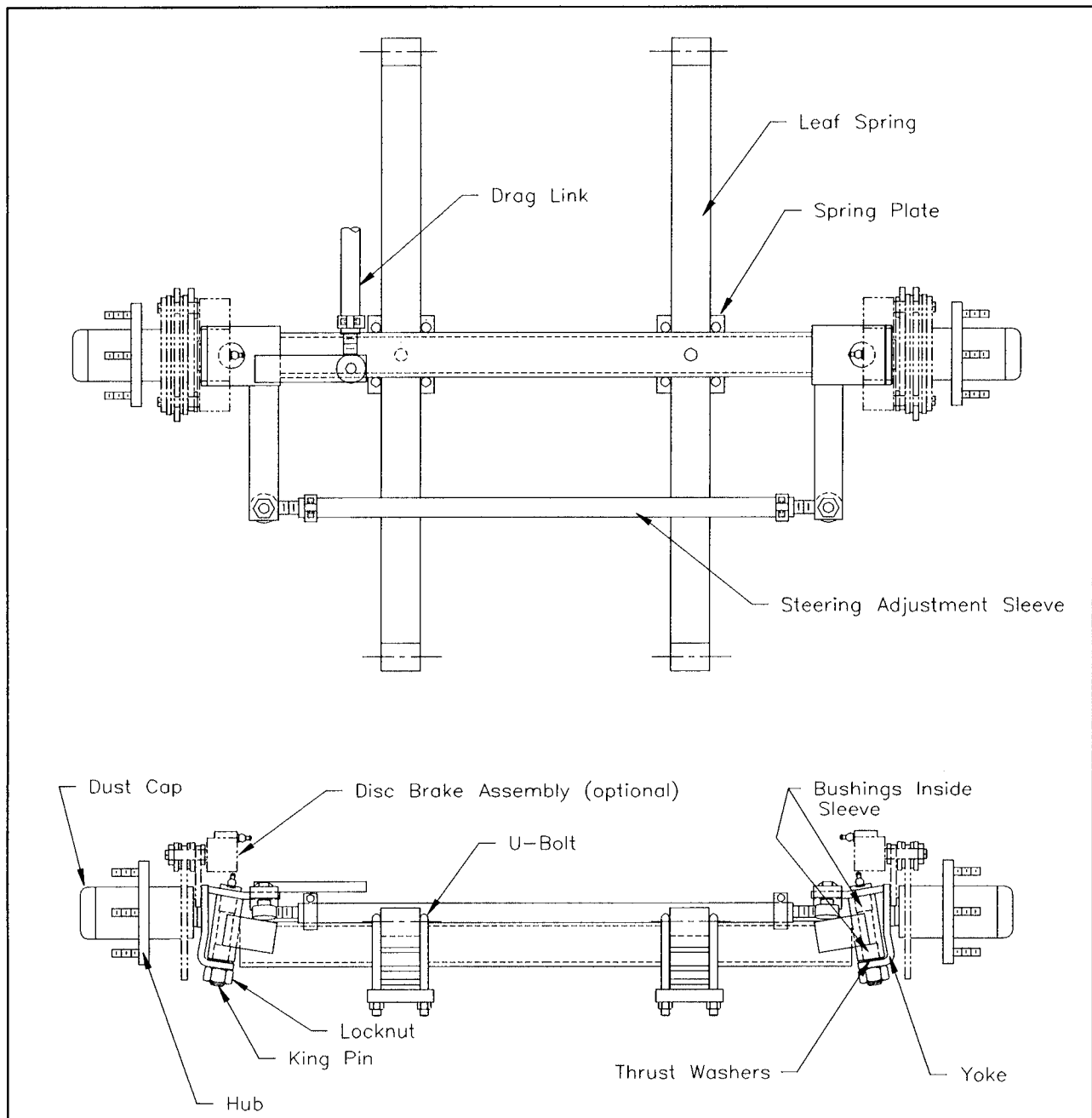

Figure 3-12

- Reinstall the leaf springs to the existing or new front axle. Refer to the Suspension Removal and Replacement procedure.
- Install yokes, thrust washers, and king pins to the ends of the axle. The king pin will have to be tapped in from the top to be seated properly.
- Tighten new locknut on the king pin until it comes in contact with the yoke. **Do not** tighten and squeeze the legs of the yoke together.
- Install the axle and springs to the vehicle frame. Use new locknuts. Tighten the nuts until tight to spring hangers, then back off 1/4 turn.

⚠ WARNING

Always use new locknuts. Locknuts become less effective after being removed, and their locking ability is diminished. Failure to use new locknuts may cause the axle to become loose from the springs and result in serious injury.

- Reinstall the drag link and steering adjustment sleeve to the yoke arms. Use new cotter pins.

⚠ WARNING

Always use new cotter pins. Cotter pins used more than once can become weak or broken. Failure to use new cotter pins may cause the ball joint to become disconnected resulting in loss of steering and serious injury.

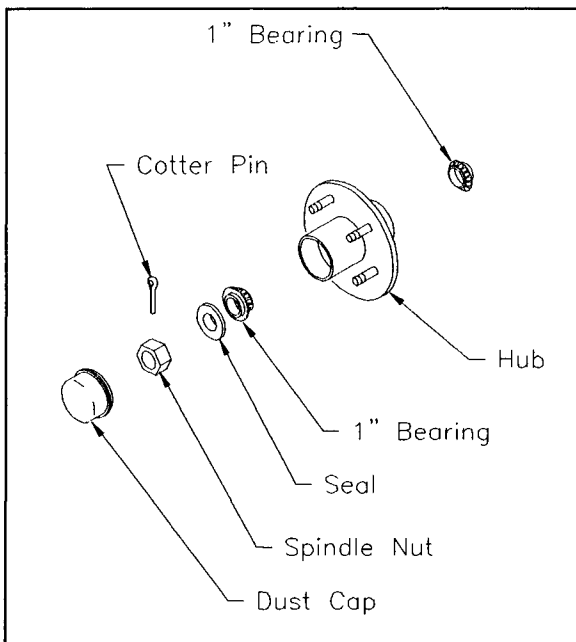

Figure 3-13

- Apply wheel bearing grease to the bearings in the hub and reinstall the hubs onto the spindles.
- Tighten the spindle nut to 30 ft-lbs while rotating the hub to seat the bearings.
- Back off the spindle nut to the next slot on the nut aligns with the cotter pin hole, and install a new cotter pin. The hub should turn freely with no bearing end play. Refer to figure 3-13.
- If equipped with hydraulic front brakes, reinstall the hydraulic brakes as described in Front Brakes section.
- Reinstall the wheels onto the hubs.
- Adjust the toe-in of the front wheels. See 'Adjusting The Toe-in'.

Adjusting The Toe-in

The toe-in is the angle of the front wheels, either in or out, and is determined by measuring the distance from the center of one tire to the center of the other tire.

Toe-in should be checked periodically as routine maintenance, and should also be set after replacement of the front axle, axle yokes, or steering adjustment sleeve.

To adjust the toe-in:

- Place blocks under the rear wheels to prevent vehicle movement.
- Disconnect the main positive and negative at the batteries.
- Raise the front end of the vehicle and support with jack stands.

⚠ WARNING

Always use a lifting strap, hoist, and jack stands, of adequate capacity to lift and support the vehicle. Failure

to use lifting and support devices of rated load capacity may result in serious injury.

- Using a marking pencil, rotate the tire while holding the pencil against the center of the tire. This will draw a line around the center of the tire. Mark both tires.
- Loosen the steering adjustment sleeve clamps, so that the sleeve may be turned.
- With the wheels straight ahead, measure the distance from the line on one tire to the line on the other tire, first at the front of the tires, then at the back. Toe-in should be 0" difference between the two dimensions, to 1/4" less on the front measurement.
- Adjust the steering adjustment sleeve until the toe-in is as described above.
- Tighten the clamps on the adjustment sleeve.

Steering

The steering system consists of the steering wheel, steering gear, pitman arm, and drag link.

Steering Removal and Replacement

To replace components of the steering system, use the following procedure and refer to figure 3-14.

- Remove the cover from the center of the steering wheel.
- Remove the nut holding the steering wheel onto the steering shaft. With the wheels straight ahead, remove the steering wheel using a steering wheel puller.
- Remove the drag link from the pitman arm.
- Remove the six bolts holding the steering column to the floorboard and remove the column, steering gear, and pitman arm.
- If the steering gear or pitman arm need to be replaced, remove the pitman arm from the steering gear output shaft.
- Remove the three bolts holding the steering gear to the steering column and remove the gear and shaft.
- Loosen the set screws on the steering shaft and remove it from the gear.

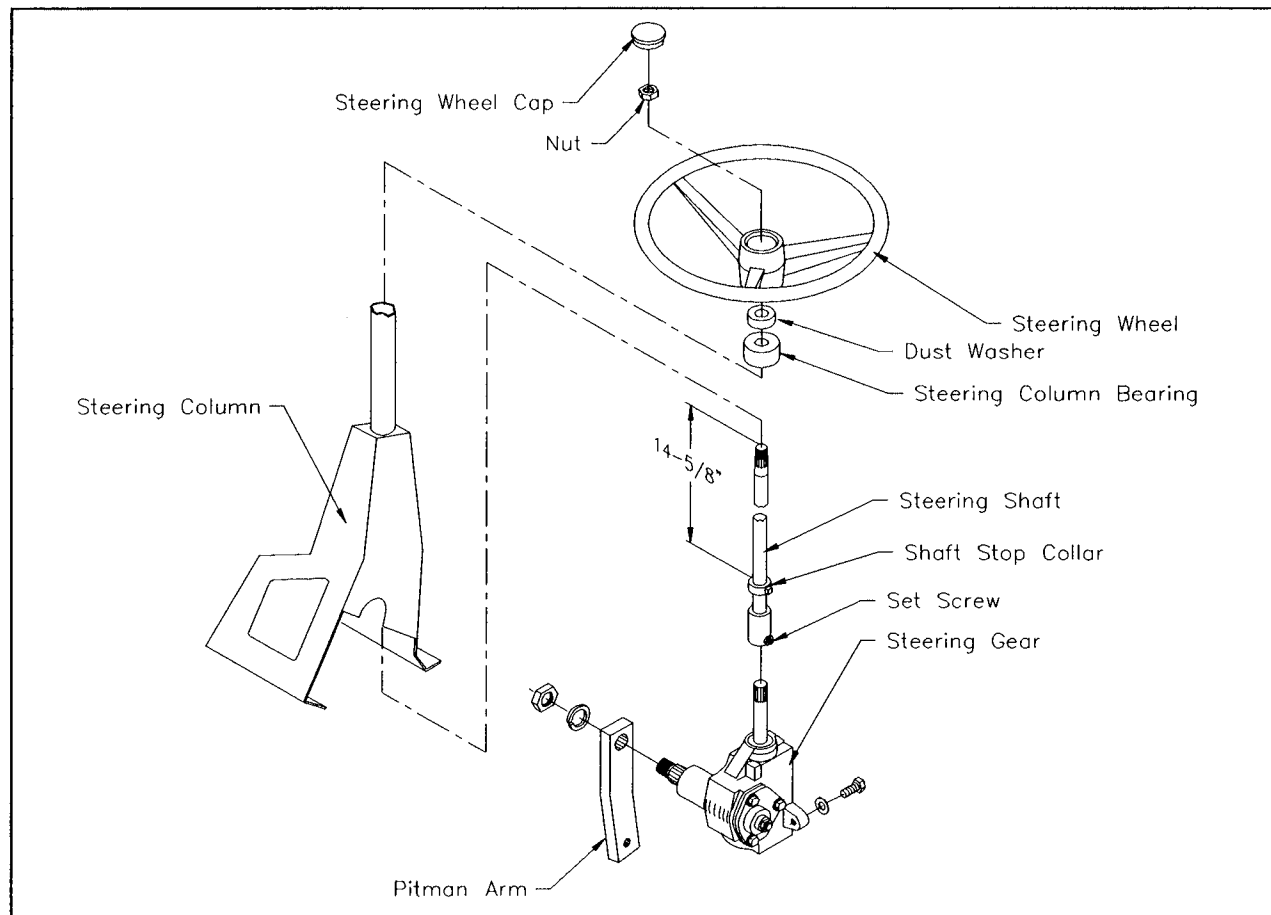

Figure 3-14

- If the steering shaft is to be replaced, remove the shaft stop collar from the shaft.
- If parts are to be replaced within the steering gear, see Steering Gear Repair procedure.
- If the steering gear must be replaced, install the steering shaft onto the new steering gear and tighten the set screw.
- Install the shaft stop collar onto the shaft and tighten at 14-5/8" from top of steering shaft (see figure 3-14).
- Install the steering gear and shaft into the steering column and tighten mounting bolts.
- Install the steering wheel onto the steering shaft and tighten down nut.
- With the steering column still loose from the vehicle, turn the steering wheel completely in one direction, then completely in the other. Count the number of turns. There should be 6-1/3 turns total.
- Start with the steering wheel turned in one direction, and turn the wheel back

toward center 3-1/6 turns and hold there.

- If the steering column has been replaced, install the steering stops to the dimensions shown in figure 3-15 and tighten down the jam nuts on each.
- With the steering column on its side, the output shaft up, install the pitman arm approximately mid-way between the steering stops and tighten down to 70 ft-lbs (see figure 3-15).
- Install the steering column to the floorboard. Use new locknuts.

▲ WARNING

Always use new locknuts. Locknuts become less effective after being removed, and their locking ability is diminished. Failure to use new locknuts may cause the steering column to become loose and could result in serious injury.

- Adjust the drag link and install to pitman arm. Use a new cotter pin-see WARNING! next page. See Drag Link Adjustment for proper adjustment.

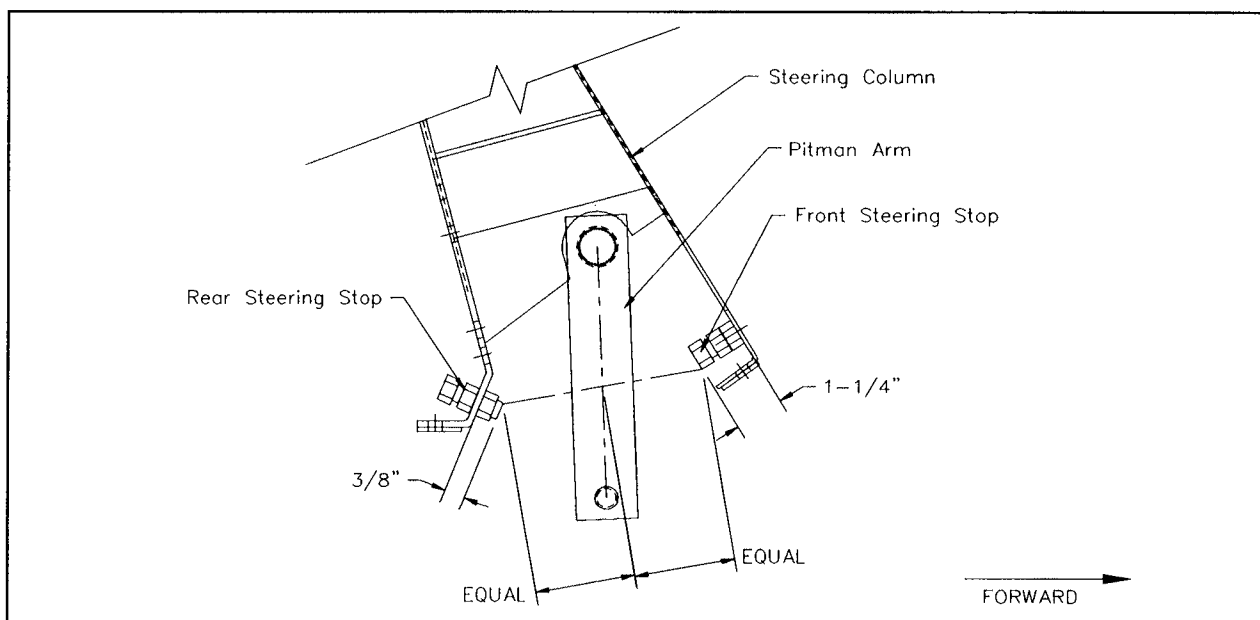

Figure 3-15

SECTION 3

Drag Link Adjustment

For proper drag link adjustment use the following procedure:

- Loosen the clamp on the drag link, on the disconnected end.
- With the wheels straight ahead, and the steering wheel and pitman arm in middle of their travel, rotate the ball joint until it slips into the pitman arm.
- Install the nut onto the ball joint and tighten. Use a new cotter pin.

⚠ WARNING

Always use new cotter pins. Cotter pins used more than once can become weak or broken. Failure to use new cotter pins may cause the ball joint to become disconnected resulting in loss of steering and serious injury.

- Tighten clamp on the drag link.

Steering Gear Adjustment

End Play

The end play of the input shaft may be adjusted so that the input shaft does not move up and down, or wobble in any way.

To adjust the end play use the following procedure and refer to figure 3-16.

- Loosen the adjustment jam nut on the bottom of the steering gear.
- Tighten the adjusting nut so that there is not end play.
- Tighten the jam nut.

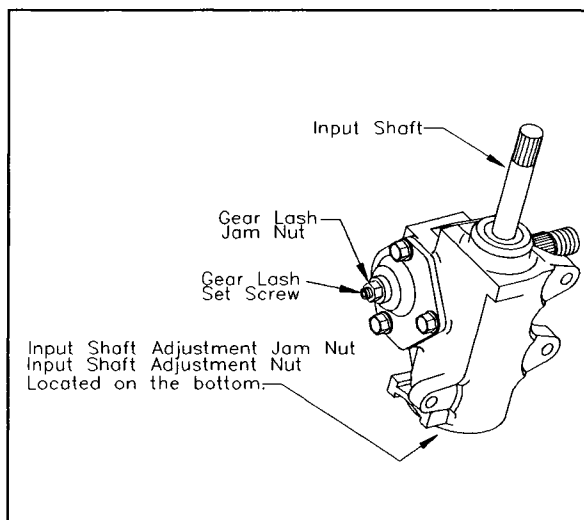

Figure 3-16

Gear Lash

The gear lash is amount of play between the input shaft and the output shaft. It is how far the input shaft is turned before the output shaft begins to move.

To adjust the gear lash use the following procedure and refer to figure 3-16.

- Disconnect the drag link from the pitman arm.
- Loosen the set screw jam nut.
- Tighten the set screw so that there is a slight drag when the steering gear passes through the center of its travel. (about 3 turns from lock).
- Tighten the jam nut. Do not allow the set screw to turn while tightening the jam nut.
- Reinstall the drag link to the pitman arm. Use a new cotter pin-see **WARNING!** on this page..

Steering Gear Disassembly and Repair

To replace components of the steering gear, use the following procedure and refer to figure 3-18.

- After removing the steering gear, mount it in a vise to hold it securely. Be careful not to damage any mounting surfaces.
- Rotate the worm shaft until it is centered.
- Remove the pre-load adjuster nut and the screws holding the side cover in place.
- Remove the side cover by turning the adjusting screw clockwise through the cover.
- Remove the adjusting screw and shim keeping them together.
- Remove the pitman shaft seal using a screwdriver or punch. Replace as necessary.
- Remove the pitman shaft from the housing.
- Remove the worm bearing adjuster locknut, worm bearing adjuster, bearing cup, and lower worm bearing. Replace as necessary.
- Remove worm shaft and ball nut assembly from housing, being careful not to damage the worm shaft seal.
- Remove the ball guide clamp, ball guides, and balls from the ball nut. Slowly turn the shaft to aid in removing the balls.
- Remove the ball nut from the shaft. Be sure all of the balls are out of the ball nut before removing.
- Remove the upper worm bearing cup using a puller and slide hammer.
- Inspect all bearings, bearing cups, seals, worm grooves, and teeth for scoring,

pitting, or wear. Replace any parts having this type of wear.

- Inspect the worm shaft seal. If damaged, remove with a screwdriver or punch, replace, and tap new seal into place.



All seals and bearings should be prelubricated before reassembly.

- Reinstall the upper bearing cup.
- Position ball nut on shaft as shown in figure 3-17.
- Divide balls into two equal groups and install into the ball nut and ball guides, using all purpose grease to help hold them in place. Rock the worm shaft slightly to aid in installing the balls.

CAUTION

Do not rotate the worm shaft while installing balls. Balls may enter the crossover passage between circuits in the ball nut, causing improper operation.

- Place upper bearing onto worm shaft.

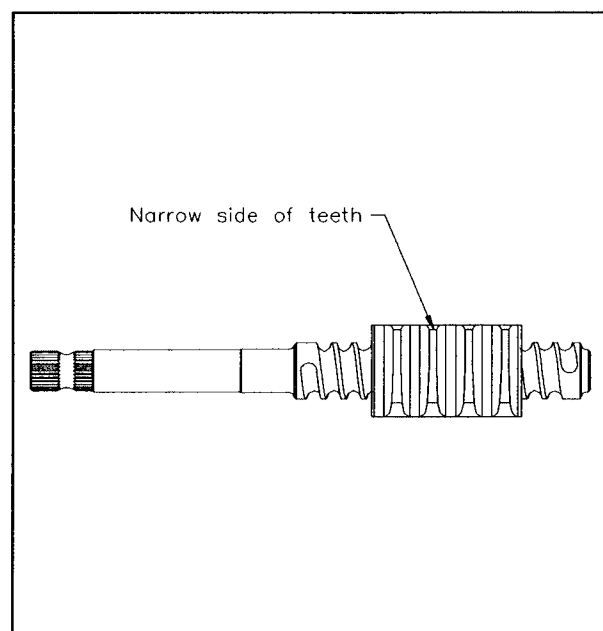

Figure 3-17

SECTION 3

- Position ball nut in the center of the worm shaft grooves and install shaft, ball nut, and bearing into the housing. Be careful not to damage the worm shaft seal.
- Install lower bearing retainer, lower worm bearing, bearing cup, worm bearing adjuster, and adjuster locknut. Adjuster should be installed just tight enough to hold the bearing in place.
- Install pitman shaft adjusting screw and shim to pitman shaft.

NOTE *Screw must be free to turn but have no more than .002" end play. If end play in screw in slot is too tight or too loose, select a new shim to give proper clearance.*

- Install the pitman shaft and adjusting screw with ball nut and pitman shaft gear centered in housing.
- Install side cover and gasket onto the adjusting screw. Turn the screw counter-

clockwise until it projects through the cover 5/8" to 3/4". Install the side cover bolts, leaving one out for injecting grease.

- Tighten the pitman shaft adjusting screw so that the teeth of the shaft and the ball nut engage but do not bind.
- Install the pitman shaft seal over the pitman shaft and into the housing.
- Fill the steering gear with high grade chassis lubricant through the side cover bolt hole.
- Turn the steering gear from one lock to the other lock checking for unusual binds.

NOTE *Never allow the ball nut to contact the ends of the ball races in the worm. Damage may occur to the ball guides.*

- Make the final steering gear adjustments as described in the Steering Gear Adjustment procedure.

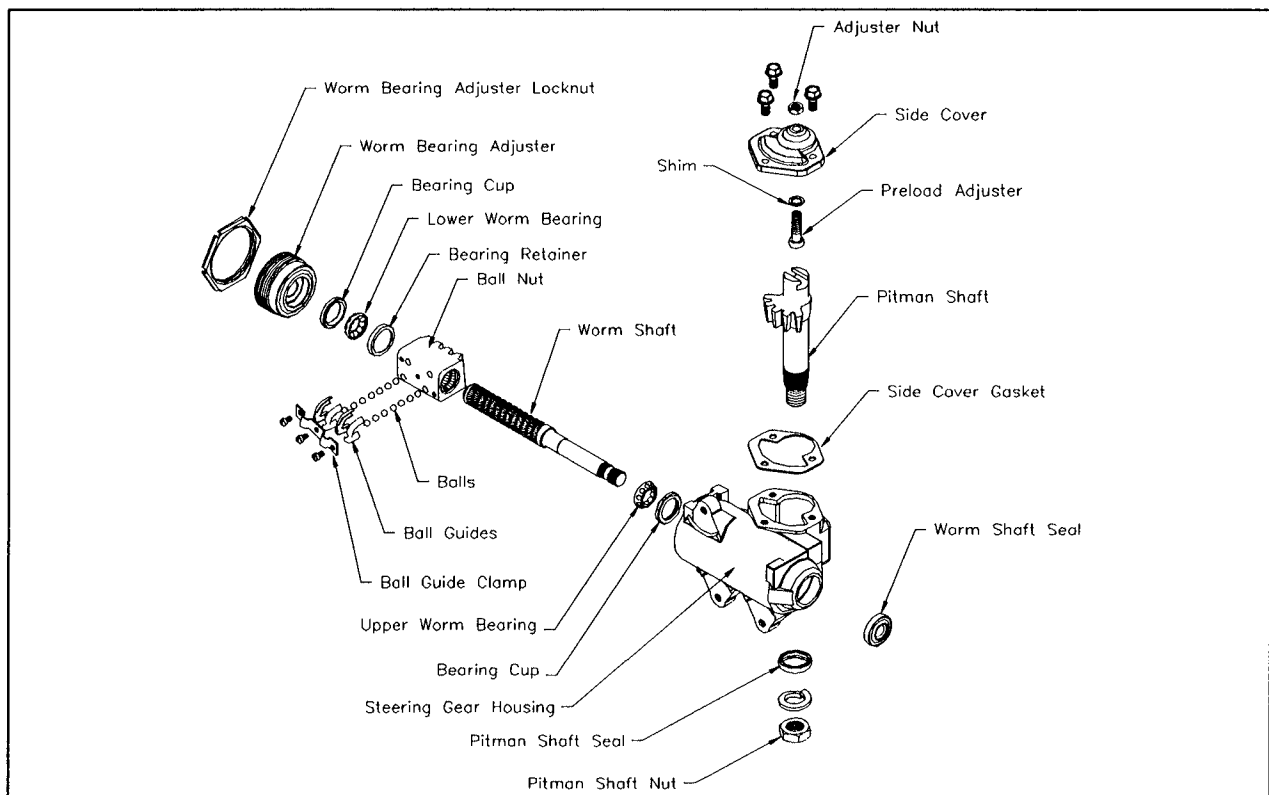

Figure 3-18

Front Suspension

The front suspension consists of the leaf springs, spring plates, u-bolts, and mounting hardware. If any of the suspension components need to be replaced, use the Suspension Removal and Replacement procedure and refer to figure 3-19.

Suspension Removal and Replacement

To remove and replace components of the suspension system:

- Place blocks under the rear wheels to prevent vehicle movement.
- Disconnect the main positive and negative at the batteries.
- Raise the front end of the vehicle, securely supporting the front axle and the vehicle frame.
- Remove the drag link from the axle.
- With the front axle properly supported, remove the leaf spring mounting bolts front and rear.

WARNING

Always use a lifting strap, hoist, and jack stands, of adequate capacity to lift and support the vehicle.

Failure to use lifting and support devices of rated load capacity may result in serious injury.

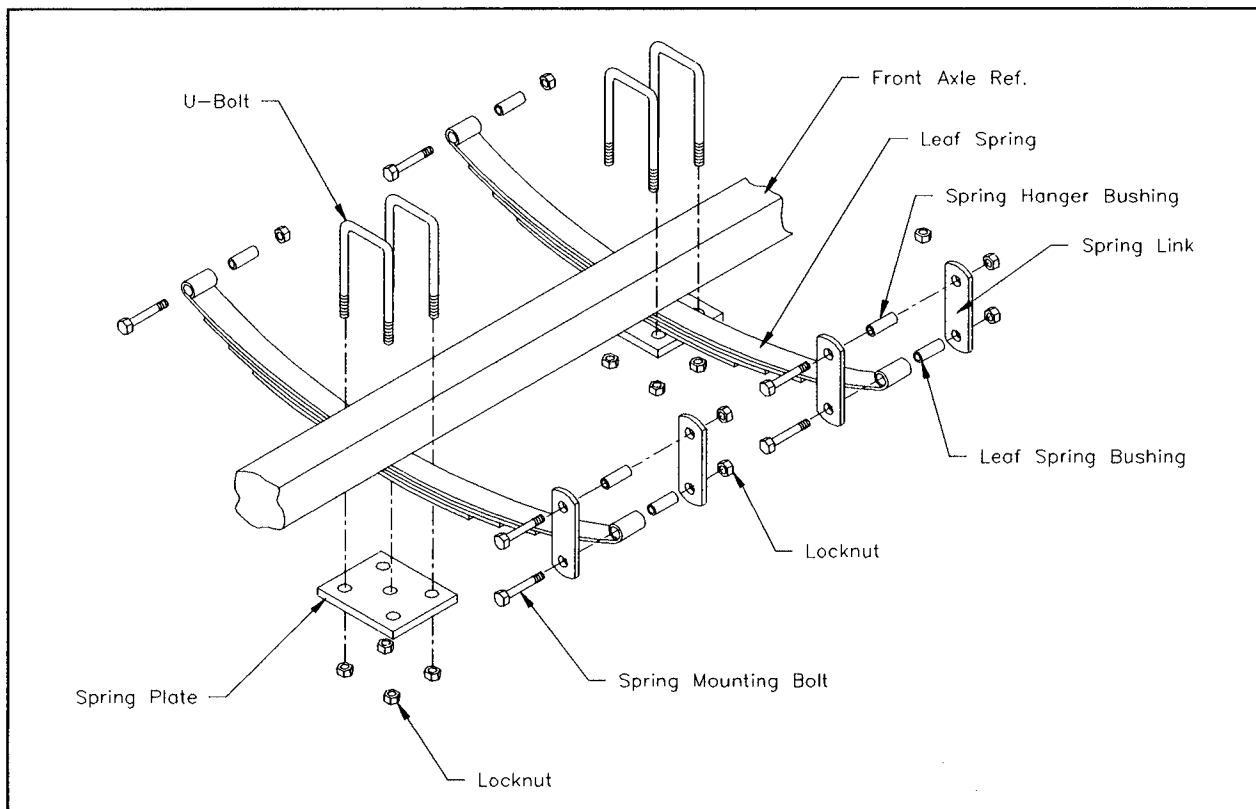

Figure 3-19

⚠ CAUTION

After the leaf springs are free from the vehicle frame, the axle will also be free from the frame. If equipped with hydraulic front brakes, do not let the axle hang on the brake hoses, as they will become damaged. The axle must be properly supported in its original position.

- Remove the u-bolts holding the springs to the axle. Be careful not to let the leaf springs fall suddenly.
- Remove the leaf springs from the vehicle.
- Inspect the bushings in the leaf spring eyes for wear and replace as necessary.
- Remove the rear spring links and inspect the bushings in the frame spring hanger for wear and replace as necessary.
- If the leaf springs are to be replaced, install them to the front axle leaving the u-bolts and nuts slightly loose. The leaf springs must be allowed to move to ensure a proper fit to the frame mounts. Use new locknuts.

⚠ WARNING

Always use new locknuts. Locknuts become less effective after being removed, and their locking ability is diminished. Failure to use new locknuts may cause the axle to become loose from the springs and result in serious injury.

- Install leaf springs to the frame and tighten. Use new locknuts-see previous WARNING!
- Adjust the drag link if necessary, and install drag link to the axle arm. Refer to Drag Link Adjustment procedure.

- Lower the vehicle and test drive.

Front Shocks Replacement (optional)

If your vehicle is equipped with front shocks, use the following procedure to remove and replace them. Refer to figure 3-20.

- Place blocks under the rear wheels to prevent vehicle movement.
- Disconnect the main positive and negative at the batteries.
- Raise the front end of the vehicle and support with jack stands.

⚠ WARNING

Always use a lifting strap, hoist, and jack stands, of adequate capacity to lift and support the vehicle.

Failure to use lifting and support devices of rated load capacity may result in serious injury.

- Remove the nuts and washers holding the shocks to the mounts.
- Remove the lower shock mounts.
- Remove the shocks from the vehicle.
- Install the new shocks to the upper mount and install the nuts and washers loosely. Use new locknuts-see WARNING!
- Install the lower shock mounts into the shocks and install the nuts and washers loosely. Use new locknuts-see WARNING!
- Install the lower shock mount onto the u-bolts and tighten down the nuts. Use new locknuts-see WARNING! on previous page.

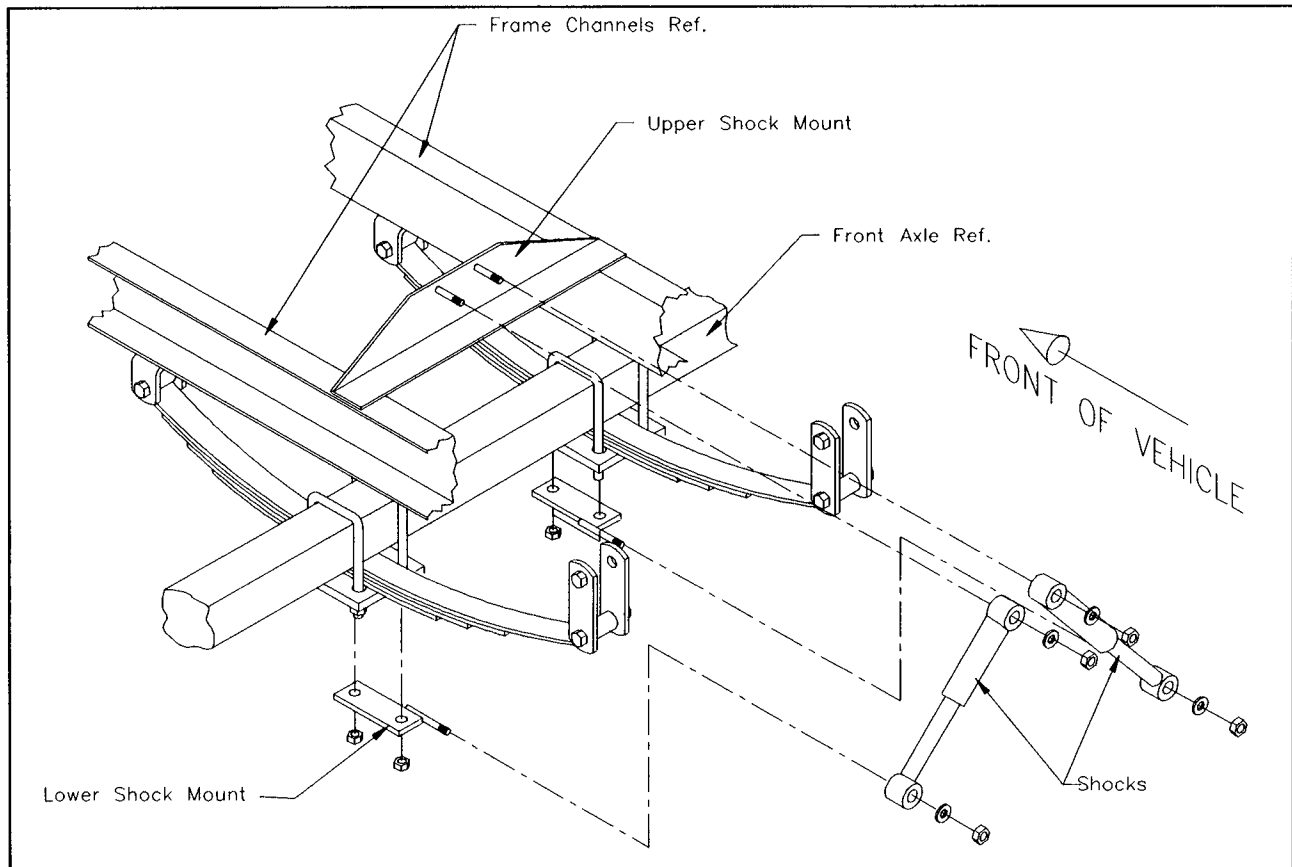

Figure 3-20

NOTE *Raise or lower the vehicle to allow the lower shock mount to sit flat on the spring plate and be installed with minimum of effort.*

- Tighten the nuts holding the shocks to the mounts.
- Lower the vehicle and test drive.

Rear Suspension

The rear suspension consists of the leaf springs, spring plates, and mounting hardware. If any of the suspension components need to be replaced, use the Suspension Removal and Replacement procedure, and refer to figure 3-21.

Suspension Removal and Replacement

To remove and replace components of the suspension system:

- Place blocks under the front wheels to prevent vehicle movement.
- Disconnect the main positive and negative at the batteries.

- Raise the rear of the vehicle, securely supporting both the differential and the frame of the vehicle.

⚠ WARNING

Always use a lifting strap, hoist, and jack stands, of adequate capacity to lift and support the vehicle. Failure to use lifting and support devices of rated load capacity may result in serious injury.

- Remove the nuts holding the lower spring plate to the leaf springs.
- Remove the spring mounting bolts from

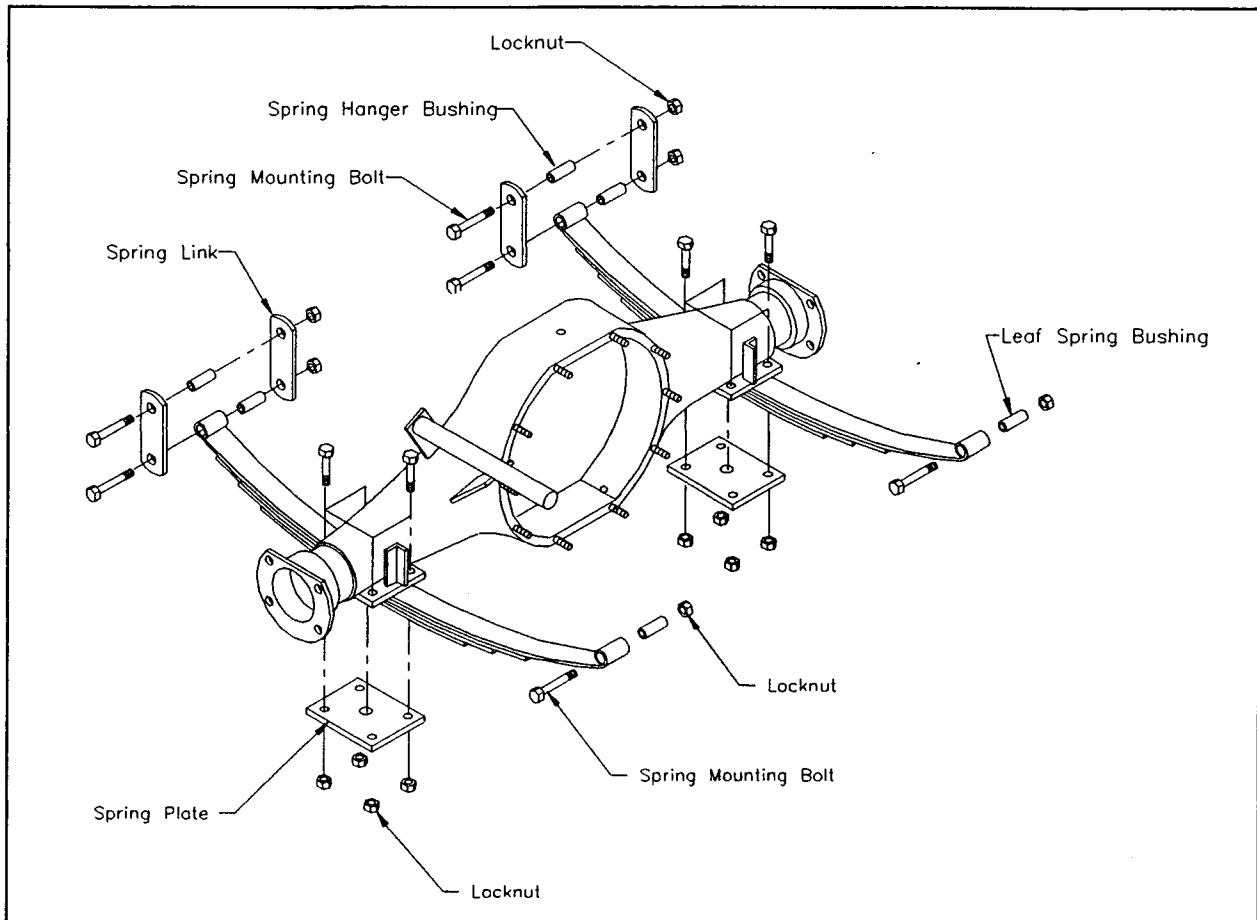

Figure 3-21

- Remove the spring mounting bolts from the front of the springs.
- Remove the spring mounting bolts from the rear of the springs, being careful not to let the spring drop suddenly.
- Inspect the leaf spring or the leaf spring bushings and replace as necessary.
- Remove the bolt holding the spring links to the rear spring mounts.
- Inspect the rear spring mount bushings and replace as necessary.
- Reinstall the spring links, but don't tighten completely. Use new locknuts.

▲WARNING

Always use new locknuts. Locknuts become less effective after being removed, and their locking ability is diminished. Failure to use new locknuts may cause the differential or the springs to become loose and result in serious injury.

- Install the front and rear spring mounting bolts and tighten until the nut contacts the mount or link. Use new locknuts.
- Install the bolts and nuts to the lower spring plate and tighten. Use new locknuts.
- Lower vehicle and test drive.

Rear Shock Replacement (optional)

If your vehicle is equipped with rear shocks, use the following procedure to remove and replace them. Refer to figure 3-22.

- Place blocks under the front wheels to prevent vehicle movement.
- Disconnect the main positive and negative at the batteries.
- Raise the rear end of the vehicle and support with jack stands.

▲WARNING

Always use a lifting strap, hoist, and jack stands, of adequate capacity to lift and support the vehicle.

Failure to use lifting and support devices of rated load capacity may result in serious injury.

- Remove the nuts and washers holding the shocks to the mounts.
- Remove the lower shock mounts.
- Remove the shocks from the vehicle.
- Install the new shocks to the upper mount and install the nuts and washers loosely. Use new locknuts-see WARNING! this page.
- Install the lower shock mounts into the shocks and install the nuts and washers loosely. Use new locknuts-see WARNING! this page.
- Install the lower shock mounts onto the lower spring plates and tighten down the nuts. Use new locknuts-see WARNING! this page.

NOTE *Raise or lower the vehicle to allow the lower shock mount to sit flat on the spring plate and be installed with minimum of effort*

SECTION 3

- Tighten the nuts holding the shocks to the mounts.
- Lower the vehicle and test drive.

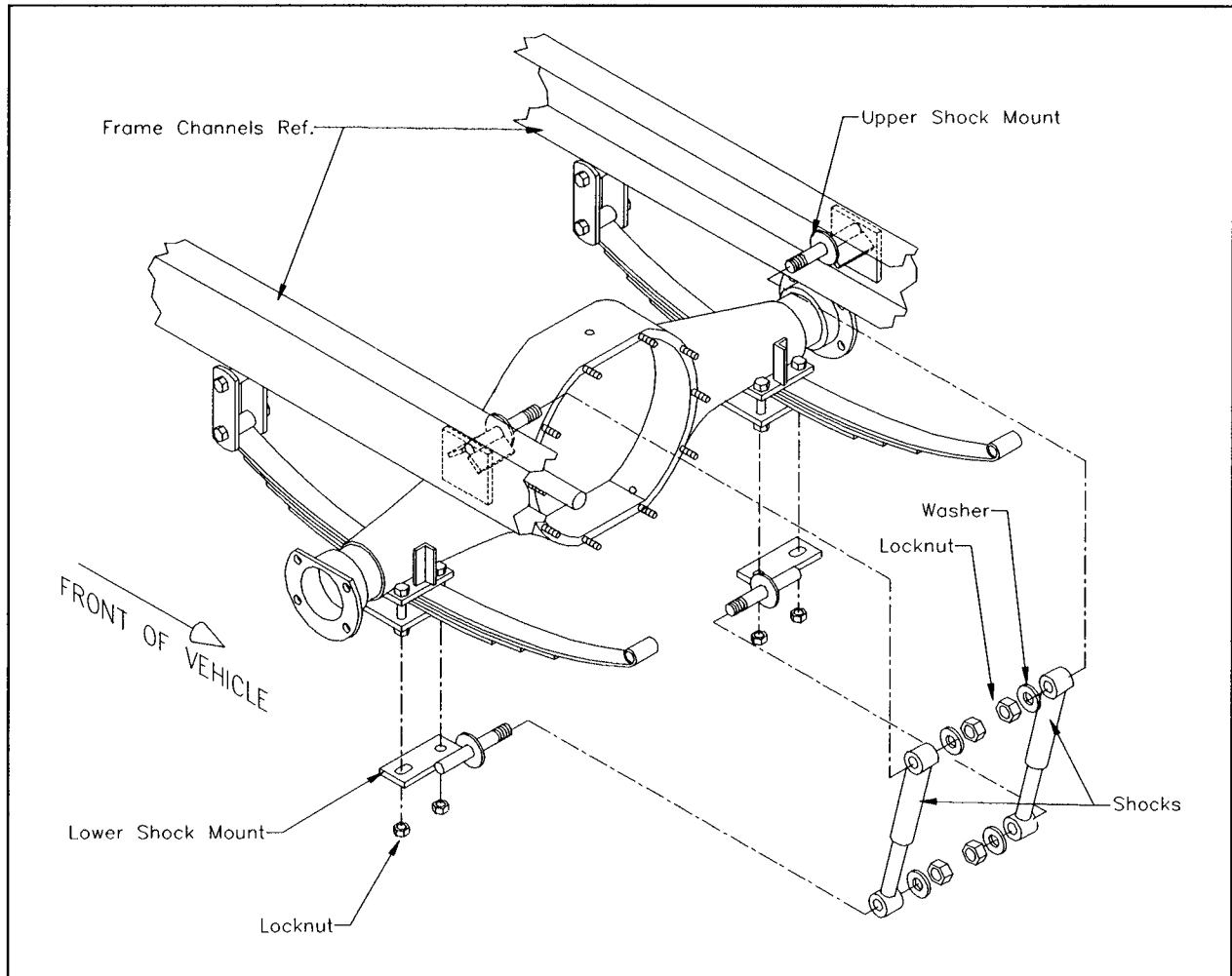

Figure 3-22

Rear Drive and Differential

BELT DRIVE

The belt drive system uses an automotive type differential which is driven by two pulleys and four v-belts.

Belt Adjustment

The drive belts will loosen during normal use and should be adjusted to ensure maximum performance. Use the following procedures for belt adjustment. Refer to figure 3-23 and 3-24.

- Disconnect the main positive and negative at the batteries.
- Place blocks under the rear wheels to prevent vehicle movement.
- Slightly loosen the nuts on the motor mount.
- Loosen the jam nut on the motor adjustment bracket.
- Turn the adjustment bolt on the adjustment bracket until the belts have a deflection of 1/4" max. for each belt.
- Tighten the jam nut on the adjustment bracket.
- Tighten the nuts on the motor mount.

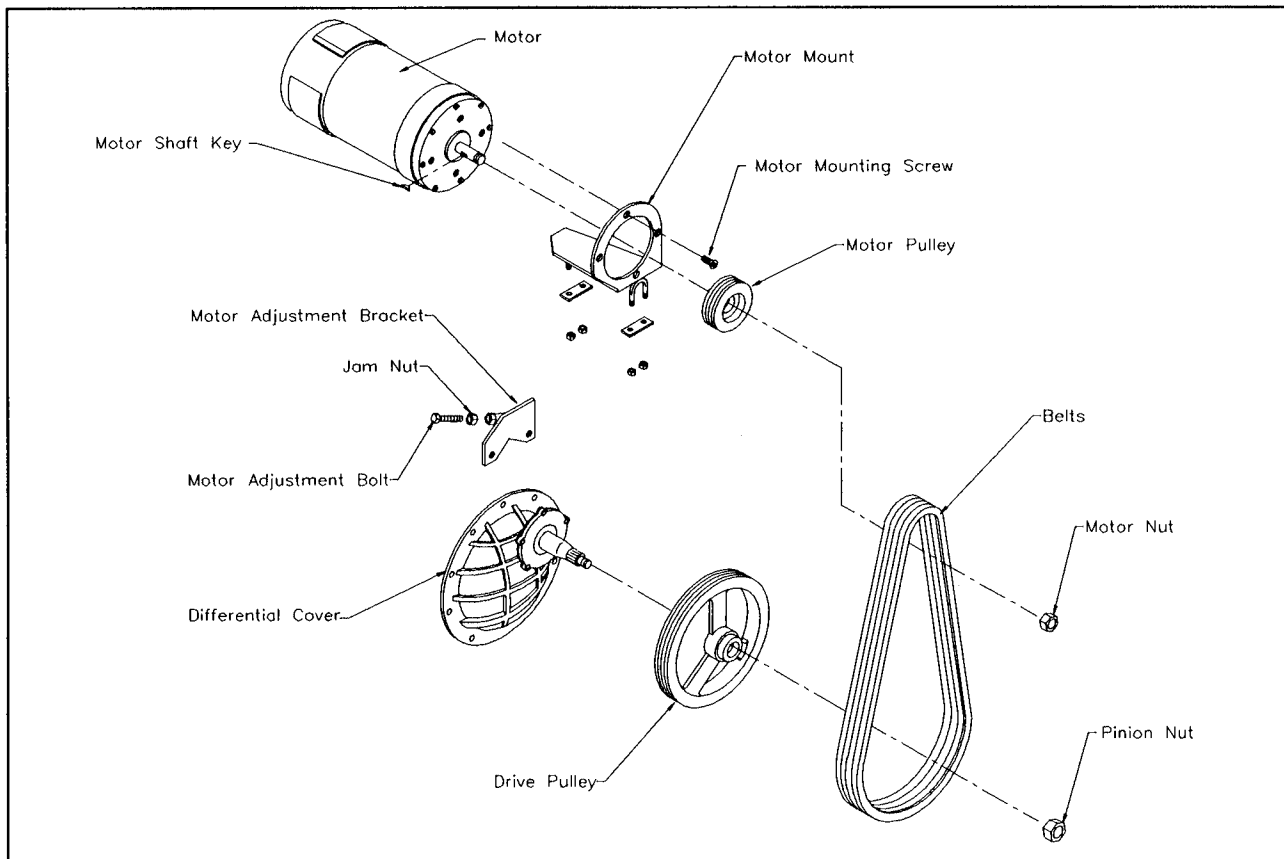

Figure 3-23

SECTION 3

Belt and Pulley Replacement

If the belts or pulley need to be replaced, use the following procedure. Refer to figure 3-23.

- Disconnect the main positive and negative at the batteries.
- Place blocks under the rear wheels to prevent vehicle movement.
- Slightly loosen the nuts on the motor mount.
- Loosen the jam nut on the motor adjustment bracket.
- Turn the adjustment bolt on the adjustment bracket until the belts are loose enough to remove from the motor pulley.
- Remove and replace the motor pulley or the drive pulley as necessary.
- Install new pulleys using new nuts. Torque the pinion nut to 175 ft-lbs.

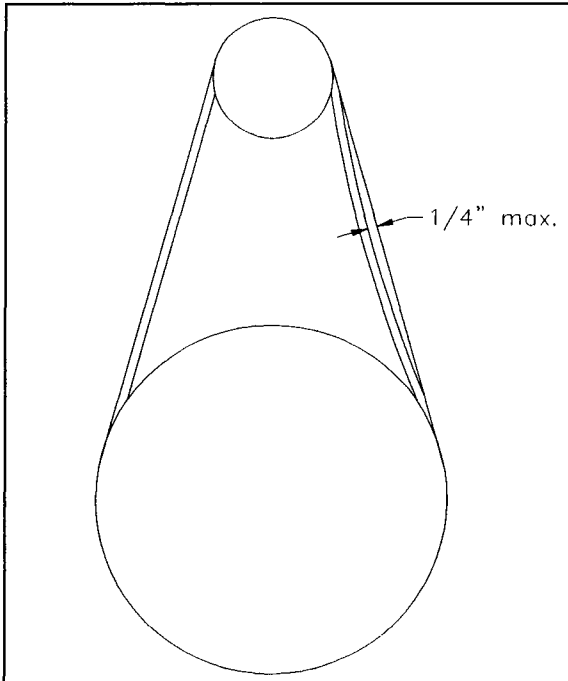

Figure 3-24

- Install new belts as necessary.
- Turn the motor adjustment bolt until the belts are tight. See Belt Adjustment procedure.
- Tighten the jam nut on the adjustment bracket.
- Tighten the nuts on the motor mount.

POWER TRACTION DRIVE (optional)

The power traction direct drive system uses an automotive type differential which is driven by the fully sealed chain and sprockets. The drive chain is enclosed in the chain case and is lubricated by oil from within. The chain connects the motor to the differential with a small and a large gear of a specified size and ratio.

Drive Chain Adjustment

The drive chain will loosen during normal use and should be adjusted to ensure maximum performance. Use the following procedures for chain adjustment.

To adjust the drive chain:

- Disconnect the main positive and negative at the batteries.
- Place blocks under the rear wheels to prevent vehicle movement
- Place a drip pan under the chain case to catch any oil that may spill.
- Loosen the nuts on the motor mounting plate just enough to let the motor and plate move freely (see figure 3-25).
- Loosen the chain adjusting screw jam nut.

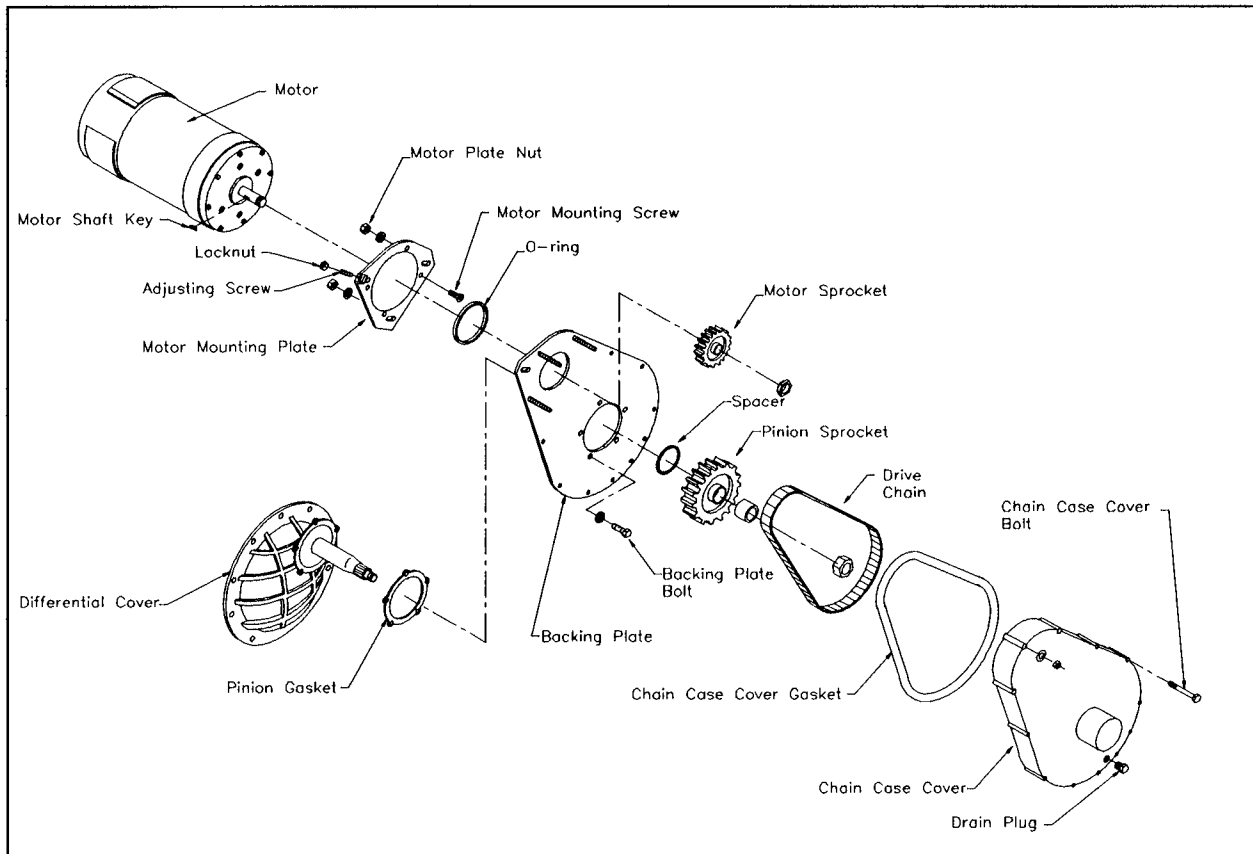

Figure 3-25

For vehicles using a motor in which the motor fan is visible through the motor side vents, use the following procedure:

- Turn the chain adjusting screw and tighten the chain so that the ends of the motor fan blades have 1/8" to 1/4" free play.
- Tighten the three motor mounting plate nuts.
- Tighten the chain adjusting screw locknut while preventing the adjusting screw from turning.



If the top of the adjusting screw is close to the jam nut (1/16"), it is time to replace the drive chain.

Chain Adjustment Schedule	
Interval	Period
First	100 hours
Second	200 hours
Thereafter	Every 400 hours

For vehicles using a motor that does not have a motor fan, use the following procedure:

- Block the front wheel, front and rear.
- Raise the rear of the vehicle so that the rear tires are just off the ground.

▲WARNING

Always use a lifting strap, hoist, and jack stands, of adequate capacity to lift and support the vehicle.

Failure to use lifting and support devices of rated load capacity may result in serious injury.

- Connect the main battery leads.
- Press on the accelerator and run the drive at moderate speed.
- Tighten the adjusting screw until the drive noise noticeably rises, then back off the adjusting screw to the point where the drive noise lowers.

Drive Chain and Sprocket Replacement

Should the drive chain or sprockets become worn or damaged, use the following procedures for replacing these parts.

To replace the drive chain or sprockets:

- Disconnect the main positive and negative at the batteries.
- Place blocks under the wheels to prevent vehicle movement.
- Depress the foot pedal forward to the full on position. Hold the foot pedal or the mechanical control linkage in this position to remove the brake drum and shoe.
- Loosen and remove the 1/2" bolt and the brake shoe assembly components (see figure 3-25).
- Remove the pinion nut and brake drum.
- Remove the drain plug and drain the oil from the chain case housing.

- Remove the bolts holding the chain case cover to the backing plate, and remove the chain case cover.
- Loosen the nuts on the motor mounting plate just enough to let the motor and plate move freely.
- Loosen the chain adjusting screw completely.
- Remove the drive chain, and if necessary the pinion sprocket and motor sprocket. Note the position and location of the spacers behind the pinion sprocket for proper reassembly.
- Install new sprockets and drive chain as needed.
- Use a new pinion seal and gaskets for the chain case cover.
- To properly center the pinion seal onto the pinion shaft, insert a centering tool (Taylor-Dunn® # 41-352-01) onto the outside of the chain case cover.

▲WARNING

If the chain case and pinion seal is not centered correctly, the seal will leak oil onto the brake drum and shoe.

This may cause the brake to fail and lead to serious injury.

- Install the old pinion nut and tighten to 100 ft-lbs.
- Install the brake drum and shoe assembly.
- Remove the old pinion nut and install the new pinion nut, and tighten to 175 ft-lbs.

- Add 1 pint of hypoid gear oil to the chain case at the fill plug. See the lubrication chart at the beginning of this section for the specified oil type.
- Adjust the chain tension as described in the 'Drive Chain Adjustment' procedure.

Differential Service and Repair

If the internal components of the differential are determined to be worn and need to be replaced, use the following procedure. Refer to figure 3-26.

To disassemble the differential:

- Disconnect the main positive and negative at the batteries.

- Block the front wheel, front and rear.
- Raise the rear of the vehicle so that the rear tires are just off the ground.

⚠ WARNING

Always use a lifting strap, hoist, and jack stands, of adequate capacity to lift and support the vehicle.

Failure to use lifting and support devices of rated load capacity may result in serious injury.

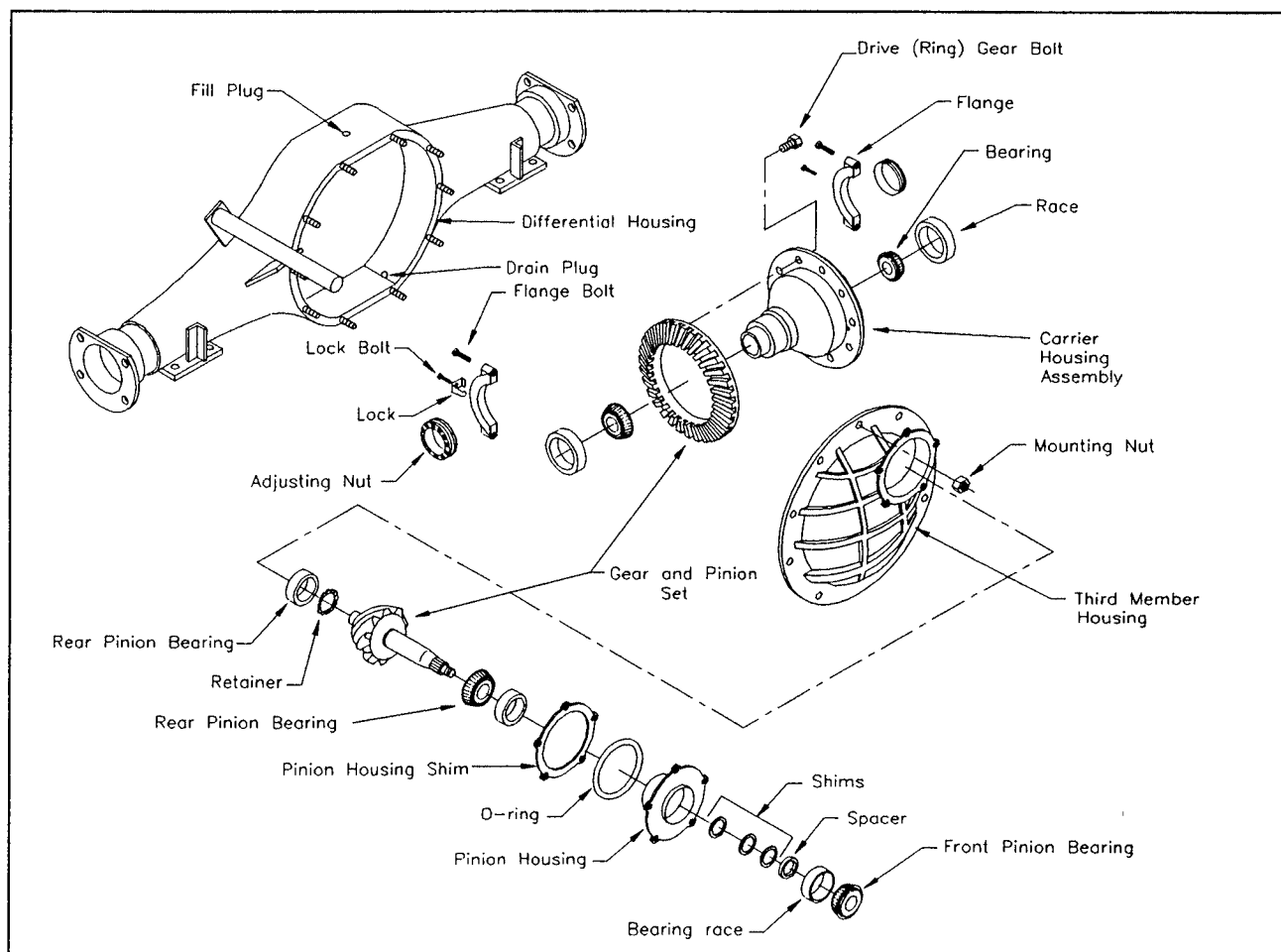

Figure 3-26

SECTION 3

- Drain the oil from the chain case and remove the brake, chain case cover, chain, and sprockets, as described the 'Drive Chain and Sprocket Replacement' section.
- Carefully remove the motor from the chain case backing plate. Support the motor while removing the mounting nuts, as it is heavy and may damage the mounting studs, or drop suddenly.
- Remove the rear wheels.
- Drain the oil from the differential by removing the drain plug.
- At this point the drive should be removed from the frame. The drive will be much easier to work on.
- Lower the vehicle until the drive is just supported and remove the drive mounting bolts.
- Raise the rear of the vehicle and remove the drive from the vehicle.
- Using a slide hammer, remove the axles about 4" from the drive housing.
- Remove the third member housing by removing the mounting nuts from the drive.
- Remove the carrier bearing flanges and the carrier assembly from the housing.
- Remove the pinion housing from the third member. Do not lose the shims from the pinion housing.
- Replace any worn or damaged bearings, races, or gears. Use new seals.
- Lubricate all bearings and gears during assembly.
- If the ring gear is disassembled from the carrier housing, the ring gear mounting bolts should be tightened to 72 ft-lbs upon reassembly. Tighten the bolts in a diagonal pattern, not a circular pattern.
- If the pinion bearings or gears are replaced, the pinion housing must be re-shimmed. See the procedure-'Shimming The Pinion Housing'.

Shimming The Pinion Bearing

If a pinion bearing is replaced, the bearing shims that were originally installed with the bearings may or may not work with the new bearing(s). If more shims are needed, see the Illustrated Parts List section on the differential third member for shim part numbers.

To check the pinion bearings and shims:

- Lubricate the bearings with general purpose grease, or oil from the drive.

CAUTION

Always lubricate the internal moving parts of the drive. Failure to apply lubricant to newly replaced or otherwise unlubricated parts will cause damage to those parts, and may lead to a breakdown of the system.

- With the pinion housing removed from the differential third member, install the drive sprocket and brake drum, or an equivalent spacer, onto the pinion shaft. Tighten to 100 ft-lbs.
- The pinion gear should turn freely with zero radial play, or movement.
- Disassemble the pinion housing and add or remove shims as required.

Shimming The Pinion Housing

If the pinion gear is replaced, a new pinion housing shim may be required for the proper mesh, or seating of the pinion gear to the ring gear.

On the flat surface of the small shaft end of the pinion gear is located a number. This number designates a decimal number to be added or subtracted to the standard shim size (see Adjustment to Standard Shim table). The standard shim thickness is .015". Shims are available in thicknesses from .005" to .021", in increments of .001" (i.e. .006", .007" etc.).

Use the following table to match the number on the pinion gear and determine the shim thickness needed for that particular pinion gear. Example:

The number on the pinion gear shaft is +4.

$.015" + .004" = .019"$ =shim thickness.

Adjustment Of Standard Shim	
If the number is:	Adjust standard by:
+0	No adjustment
+1	Add .001
+2	Add .002
+3	Add .003
+4	Add .004
+5	Add .005
-1	Subtract .001
-2	Subtract .002
-3	Subtract .003
-4	Subtract .004
-5	Subtract .005

Backlash Adjustment

The backlash is the amount of play of the ring gear when meshing with the pinion gear.

To adjust the backlash:

- Install the correctly shimmed pinion gear and housing to the third member housing.
- Temporarily install the drive sprocket and brake drum to the pinion shaft. Torque the old pinion nut to 100 ft-lbs.
- Install the carrier housing and ring gear assembly. Tighten the carrier bearing flange bolts to 15 ft-lbs.
- Move the carrier housing and ring gear tight to the pinion gear.
- Tighten the carrier bearing adjusting nuts to contact the bearings.
- Slightly loosen the adjusting nut on the ring gear side of the third member.
- Tighten the adjusting nut on the opposite side to eliminate backlash, but not so tight as to cause binding.
- Tighten the adjusting nut on the ring gear side so that the backlash is .008" to .012".
- Tighten the carrier bearing flange bolts to 40-55 ft-lbs.

SECTION 3

To reassemble the differential and drive:

- Reverse the procedures used for disassembly.
- Lubricate all bearings, gears, and moving parts upon reassembly.
- With the differential completely assembled and rear axles installed, add 2-1/4 qts of gear oil to the differential through the fill plug. See the 'Lubrication Chart' in this section for the oil specification.

Rear Axle or Bearing Replacement

If the rear axle or bearings need to be replaced, use the following procedure.

To replace the rear axle or axle bearing:

- Disconnect the main positive and negative at the batteries.
- Block the front wheel, front and rear.
- Raise the rear of the vehicle so that the rear tires are just off the ground.

▲WARNING

Always use a lifting strap, hoist, and jack stands, of adequate capacity to lift and support the vehicle.

Failure to use lifting and support devices of rated load capacity may result in serious injury.

- Remove the rear wheel on the axle to be removed.
- Remove the four bolts holding the axle retainer and axle to the housing.
- Using a slide hammer, remove the axle from the housing.

- Remove the bearing retainer and bearing from the axle shaft with a press.
- Press the new bearing and bearing retainer onto the axle shaft. Be sure to place the axle retainer onto the shaft first.

▲WARNING

Do not reuse the old bearing retainer. Failure to install a new retainer may cause the axle to slip out of the drive and lead to serious injury.

- Remove and replace the oil seal and gasket from the housing.
- Install the axle into the housing and install the four bolts through the axle retainer and housing.

NOTE *Always use new locknuts to replace any locknuts removed from the vehicle. Locknuts can be used and removed only once. They become less effective when they are used more than one time.*

Drive Motor

The drive motor requires very little maintenance. The brushes should be inspected every one or two years for wear.

Some motors may have brush inspection cover, which can be removed for easy inspection. Motors not having brush inspection covers have a hole in which a rod can be inserted to determine brush wear. If the distance the rod travels into the hole is 1-1/2" or more, the brushes must be replaced.

If the brushes wear too much, the commutator could become damaged. If the motor or components of the motor have become damaged or need replacement, use the following procedure.

Replacement of Motor Brushes

To remove the drive motor and motor brushes on a belt drive unit:

- Place blocks under the wheels to prevent vehicle movement.
- Disconnect the main positive and negative at the batteries.
- Slightly loosen the nuts on the motor mount.
- Loosen the jam nut on the motor adjustment bracket.
- Turn the adjustment bolt on the adjustment bracket until the belts are loose enough to remove from the motor

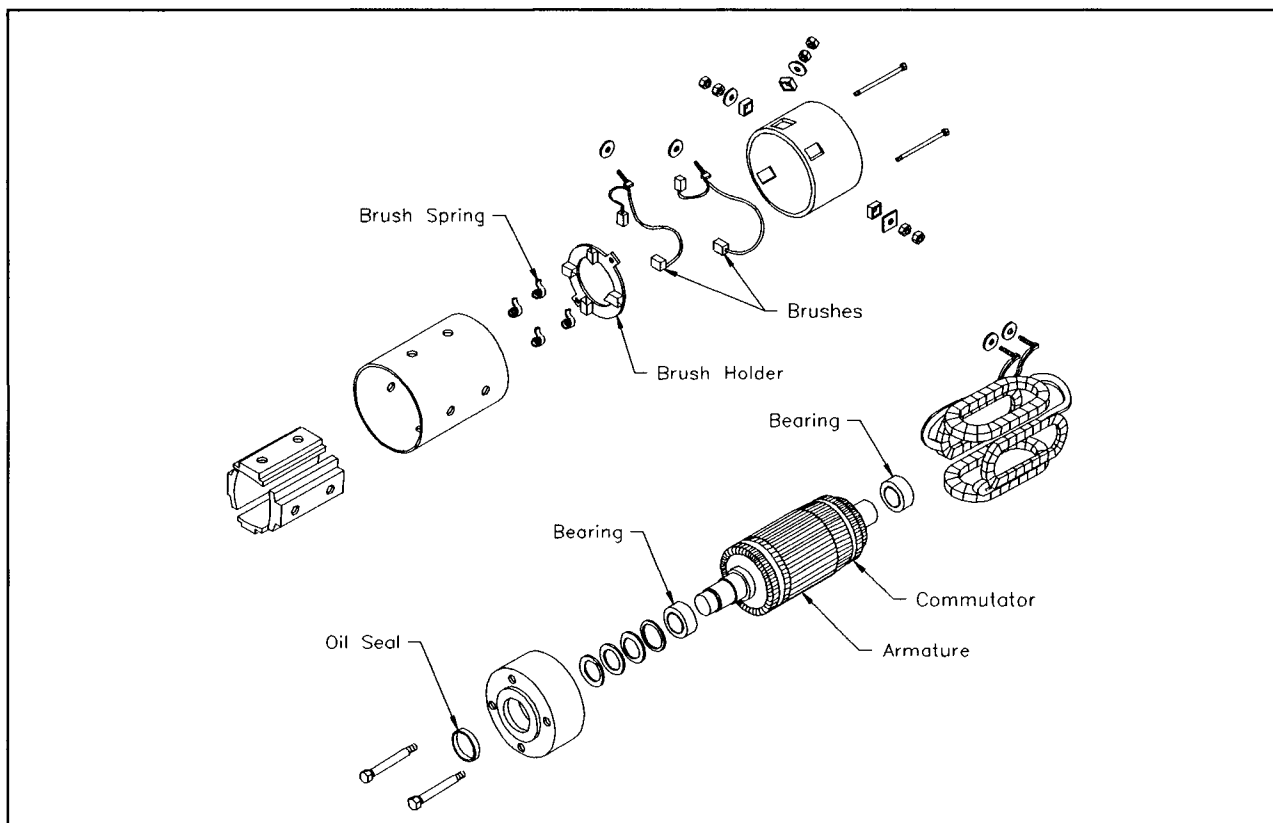

Figure 3-27

SECTION 3

pulley.

- Remove the nut holding the motor pulley in place and remove the pulley.
- With the motor properly supported, remove the four bolts holding the motor to the mount and remove the motor.

For power traction drives:

- Remove the drain plug and drain the oil from the chain case housing.
- Remove the bolts holding the chain case cover to the backing plate, and remove the chain case cover.
- Loosen the nuts on the motor mounting plate just enough to let the motor and plate move freely.
- Loosen the chain adjusting screw completely.
- Remove the drive chain and motor sprocket.
- Carefully remove the motor from the chain case backing plate. Support the motor while removing the mounting nuts, as it is heavy and may damage the mounting studs, or drop suddenly.

- Remove the motor end cover revealing the brush holder and brushes. Disassemble the brush studs from the end cover (see figure 3-27).
- Remove the worn brushes and replace as required.

NOTE *The minimum length of the brushes required for proper motor operation is 1/2". It is recommended that all the brushes be replaced at the same time.*

Armature Inspection

The armature can be removed and inspected for signs of damage as follows:

- If any solder has been thrown from the armature, the motor must be replaced. Check the inside of the motor housing around the commutator for bits of solder.
- If the commutator is grooved, it must be cut on a lathe.
- Measure the undercut on the commutator. If it is less than .025", then the mica must be undercut (see figure 3-28).
- Measure the commutator diameter. If it

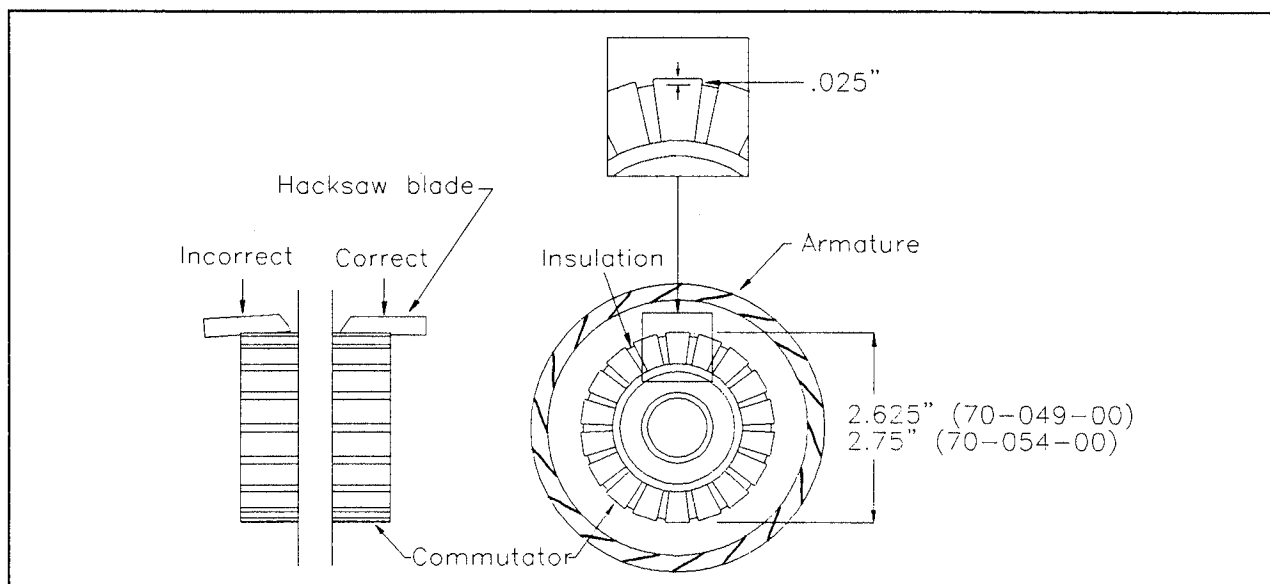

Figure 3-28

less than the minimum operational diameter, then the armature is worn out and the motor must be replaced (see figure 3-28).

- Spin the bearings by hand. If any vibration or roughness is felt, then they must be replaced. The bearings will need to be pressed out of the motor housing.
- Replace worn or damaged parts as necessary, and reassemble the motor.
- Install the motor to the motor mount but do not tighten mounting bolts completely.
- Turn the motor adjustment bolt until the belts are tight. See Belt Adjustment procedure.
- Tighten the jam nut on the adjustment bracket.
- Tighten the nuts on the motor mount.
- Lower vehicle and test drive.

Batteries

The batteries should be kept dry and clean of electrolyte, and free of dirt. This will prevent corrosion to the battery terminals and wiring, as well as a safer operating environment.

⚠ WARNING

Battery electrolyte is poisonous and dangerous. It contains sulfuric acid. Avoid contact with skin, eyes, or clothing. DO NOT INGEST. Wear rubber gloves and safety glasses when servicing the batteries.

Cleaning

Dry dirt can be easily wiped or brushed off of the batteries. Wet dirt or wetness on the covers indicates the presence of battery acid.

To clean the batteries:

- Use nonmetallic brush with flexible bristles and a strong solution of water and baking soda (1 lb of soda to 1 gal. of water) to wash the top of the batteries.
- Continue until all bubbling stops, which indicates that the acid has been neutralized. *Do not get any of the soda solution in the battery cells.*
- Rinse thoroughly with clean water.

Servicing

To check the electrolyte level:

- Check the electrolyte in all of the batteries. If low, fill with distilled water to the correct level (see figure 3-29).

⚠ CAUTION

Do not overfill the batteries. If the batteries are filled to full, they may leak electrolytic acid.

- Clean the batteries as described previously.
- Clean the cell caps, battery posts, and battery box area with water.

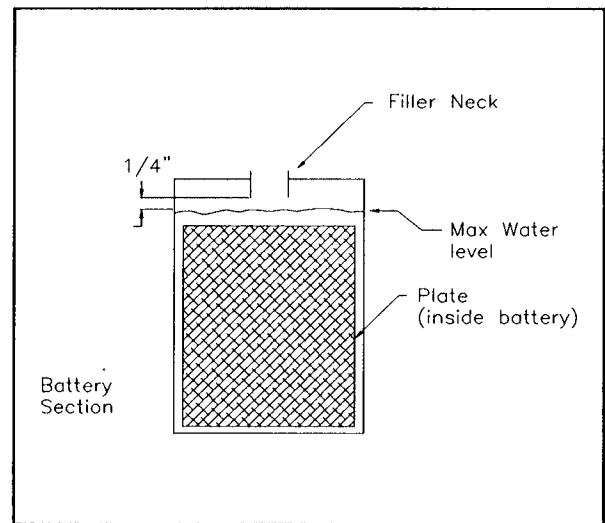

Figure 3-29

Charging**⚠ WARNING**

Batteries produce an explosive gas when charging. DO NOT smoke, produce an open flame, or sparks when checking, servicing, or charging the batteries.

⚠ WARNING

Explosive mixtures of hydrogen gas are present within the battery cells at all times. Do not charge or work on the batteries in an area where open flames (including gas furnaces, or water heaters), sparks, cigarettes, or any other source of combustion are present.

Always provide ample ventilation in rooms where batteries are being charged.

To charge the batteries:

- Check the electrolyte in all of the batteries. If low, fill with distilled water to the correct level (see figure 3-29).
- Park the vehicle in an approved area for charging, and plug the charger in.
- Allow the charger to cycle completely before unplugging.

Storage

The following pointers will help extend the life of the batteries when storing your vehicle for any reason.

- Clean and check the electrolyte and charge level of the batteries. Do not store a battery low in electrolyte or in a low state of charge.
- Recharge batteries not in use every 1 to 2 months.
- Store the vehicle in a cool dry place.
- If the batteries are removed from the vehicle, do not place them directly on the ground, concrete, or solid metal surface. Store the batteries on a wooden surface.

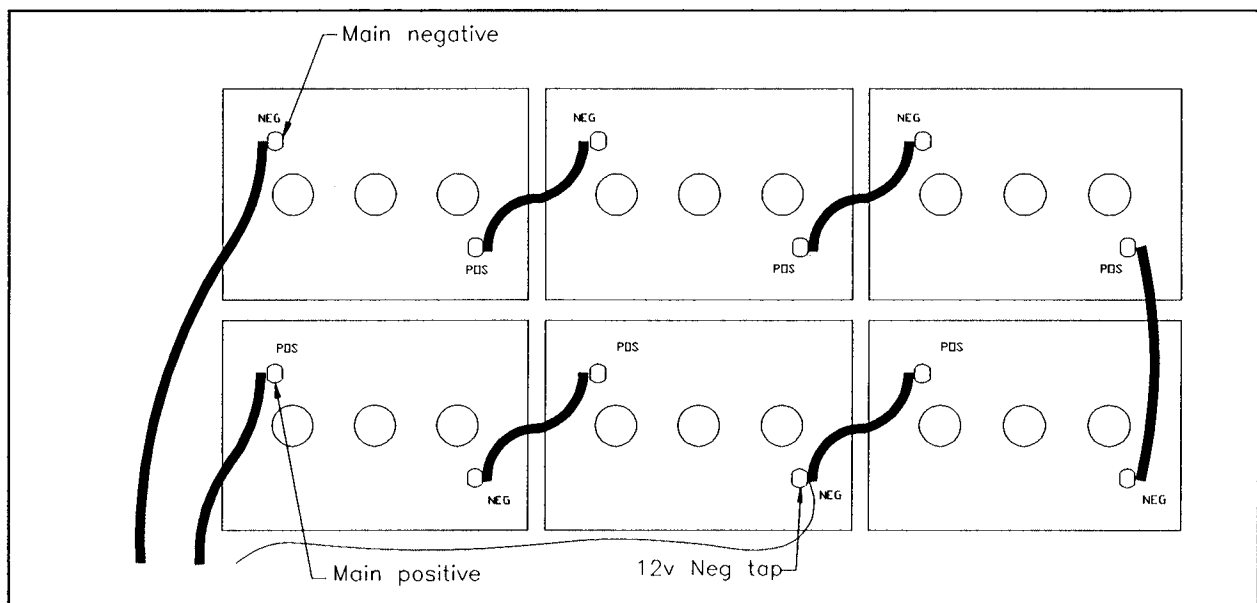

Figure 3-30 Battery Position and Wiring

Tires

The model B2-10 is equipped with 5.70" x 8.00" pneumatic load range B tires as standard equipment. Maximum tire pressure for these tires is 50 psi. The optional 8.50" x 8.00" terra tires have a maximum tire pressure of 22 psi.

⚠ WARNING

Avoid over inflating or under inflating the tires. Failure to keep the tires at the proper pressure will cause increased tire wear and could lead to tire failure. Over inflating could cause rim failure and explosion, resulting in serious or worse injuries.

For proper tire care:

- Check the tires for nicks or grooves and replace if necessary.
- Regularly check the tire pressure and inflate to the maximum pressure.
- When replacing the tire only, be sure that the tire is properly seated on the rim.

⚠ WARNING

When mounting a tire onto a rim, if the beads are not seated on the rim properly and the tire is being inflated, serious injury may occur.

⚠ CAUTION

Solid cushion tires and wheels are heavy. Use proper lifting and support devices when removing from the vehicle or transporting.

Split Rim Wheels

If your vehicle is equipped with split rim wheels, use the following procedure to disassemble the wheel.

- After the wheel is removed from the vehicle, deflate the tire by removing the valve stem core.

⚠ WARNING

Always completely deflate the tire before disassembling the split rim wheel, or removing the tire from the wheel.

Failure to deflate the tire may result in serious injury.

- Loosen and remove the bolts holding the wheel halves together.
- Replace wheel or tire as necessary.
- Reassemble wheel and tire. When assembling the wheel, be sure the tube does not get pinched between the wheel halves.
- Inflate tire to maximum pressure.

Electrical System

The model B2-10 runs on a 36 volt battery powered system, which includes a 12 volt accessory system. The electrical system consists of the control panel, accelerator module, motor, and batteries. The control panel contains the speed controller, solenoids, circuit breakers, and horn (see figure 3-31). This panel may be easily removed from the vehicle. See the Illustrated Parts List for identification of these components.

The B2-10 features an electrical interlock which disconnects the key switch circuit when the operator is not sitting in the driver's seat.

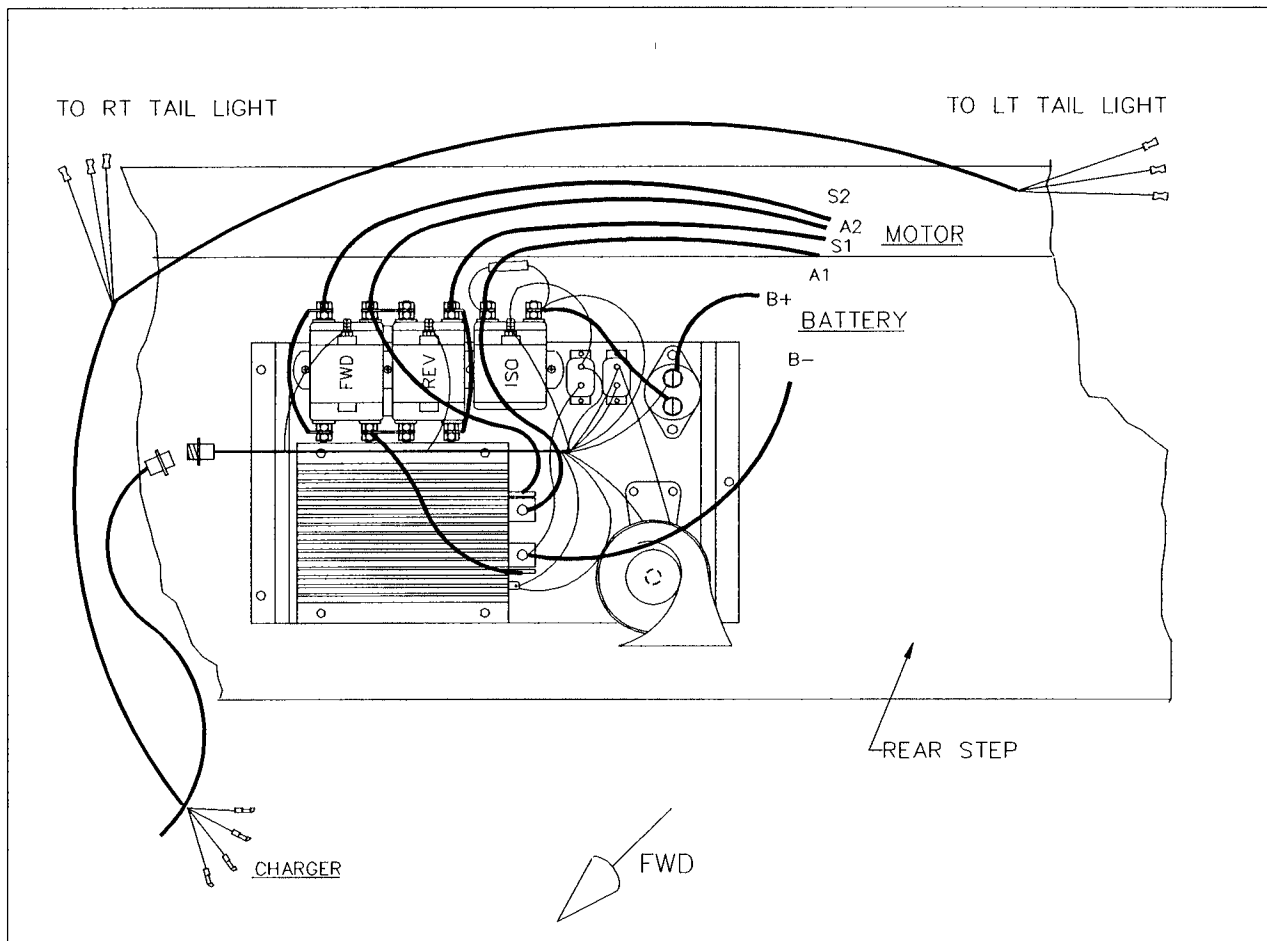

Figure 3-31

SECTION 3

ELECTRICAL TROUBLESHOOTING

If the vehicle has a problem which has been diagnosed as electrical, use the following guidelines and procedures to locate the problem.

Tools required:

Volt-Ohm meter
Test light (voltage equal to MAX battery voltage)
9/16" comb. wrench
1/2" comb. wrench
62-027-31 test harness

Parameters:

- All voltage tests done are referenced to battery negative unless otherwise specified.*
- Battery volts = full voltage available from batteries at time of test.*
- In all tests the key switch is on. Safety switches (if equipped) are on.*
- This test procedure must be performed in the order it was written. Starting the testing in the middle, or skipping sections, may result in incorrect readings and false conclusions.*
- All tests done on the motor assume that the vehicle is not running.*
- If a problem is found and corrected, and the vehicle still does not operate correctly, the testing procedure must be started again at the beginning.*

▲WARNING

DURING ALL TESTS, BOTH DRIVE WHEELS JACKED UP OFF THE GROUND, SUPPORTED BY JACK STANDS, AND WITH THE FRONT WHEEL BLOCKED.

AFTER ANY REPAIRS ARE MADE COMPLETELY TEST VEHICLE BEFORE LOWERING TO GROUND

START: If the truck runs in one direction only, go to the 'SOLENOID' section.

Control Wires at PMC

1. With the accelerator pedal depressed to engage MS1 only (creep speed), and the directional switch in forward or reverse:
 - a) Test voltage at PIN #2 on the PMC (see figure 3-32). If not 6-6.5 V, then go to 'ACCELERATOR MODULE' section.
 - b) Test voltage at PIN "KSI" on the PMC. If not battery voltage, then go to 'KSI' section.

2. With the accelerator pedal fully depressed.
 - a) Test voltage at PIN #2 on the PMC. If not 11-11.5 V, then go to 'ACCELERATOR MODULE' section.

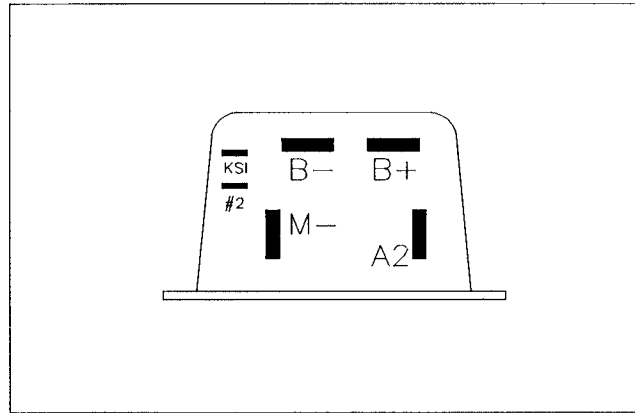

Figure 3-32

Power Wiring



All tests in this section are with the resistor at the ISO solenoid disconnected. Reconnect the resistor when done with this section.

1. With the accelerator pedal depressed to engage MS1 only (creep speed).
 - a) Test voltage from battery negative to "B+" on the PMC. If not battery voltage, then go to 'SOLENOIDS' section.
 - b) Test voltage from "B+" on the PMC to "B-" on the PMC. If not battery voltage, then check the wire and connections from battery negative to "B-" on the PMC. **>STOP**
 - c) Using the ohm meter (R x 10), check the ISO resistor. If not 250 ohms, replace the resistor.



A defective resistor causes intermittent operation of control.

2. Reconnect the resistor.
3. With the accelerator pedal depressed fully.
 - a) Test voltage from "M-" on the PMC to "B+" on the PMC. If not battery voltage, then the PMC is bad. **>STOP**
 - b) Connect the test light across MOTOR S1-S2 terminals. If the light is ON, then the field is open. **>STOP**
 - c) Connect the test light across MOTOR A1-A2 terminals. If the light is ON, then the armature is open. **>STOP**

GO TO SOLENOIDS

SECTION 3

Accelerator Module (magnetic or solid state only)

NOTE *These tests are done at the accelerator using the 62-027-31 test harness.*

1. With the accelerator pedal depressed to engage MS1 only (creep speed).
 - a) Test voltage at PIN #4. If not battery voltage, then go to 'KSI' section.
 - b) Test voltage from PIN #4(+) to PIN #9(-). If not battery voltage, then check the wire from PIN #9 to circuit breaker, and the circuit breaker. **>STOP**
 - c) Test voltage at PIN #2. If not 6-6.5 V, then the accelerator module is bad. **>STOP**
 - d) Test voltage at PIN #5. If not battery voltage, then the accelerator module is bad. **>STOP**

NOTE *A broken return spring will cause no output at PIN #5.*

1. With the accelerator pedal fully depressed.
 - a) Test voltage at PIN #2. If not 11-11.5 v. then the accelerator module may need adjusting or is bad. **>STOP**
 - b) If voltage at MODULE (PIN #2) are good but at PMC (PIN #2) are bad then check the wire in PIN #2 from the module to the PMC. **>STOP**

KSI

1. Check the key switch and/or safety interlock switches (if equipped) for continuity.
 - a) Check the forward/off/reverse switch.
 - b) Check control wiring. **>STOP**

Solenoids

1. Using an ohm meter (R x 10), check the ISO resistor. If not 250 ohms, replace the resistor.

NOTE *A defective resistor causes intermittent operation of control.*

1. If the vehicle travels forward only, then go to 'FORWARD ONLY'.
2. If the vehicle travels in reverse only, then go to 'REVERSE ONLY'.
3. Place the directional switch in the off position.
 - a) If the ISO solenoid clicks when the accelerator pedal is depressed, then go to 'ISO'.

4. Test voltage from battery positive to the ISO coil negative.
 - a) If not battery voltage, then check the negative control wiring and the circuit breaker. **>STOP**
5. With the accelerator pedal fully depressed.
 - a) Test voltage across the ISO coil. If not battery voltage, then check the wiring, MS1, safety switches, and key switch. **>STOP**
 - b) Test voltage across the ISO coil. If battery voltage, then the ISO coil is bad. **>STOP**

ISO

1. Connect the test light across the ISO power contacts and depress the accelerator pedal fully.
 - a) If the light is on, then the ISO solenoid is bad. **>STOP**
 - b) If the light is off, then check the power wiring to the batteries and to the PMC for opens. **>STOP**

FORWARD ONLY

1. Place the directional switch in neutral.
2. Depress the accelerator pedal. Move the directional switch to reverse.
 - a) If the reverse solenoid clicks, then go to 'REVERSE CONTACTS'.
 - b) If the reverse solenoid does not click, check voltage from battery positive to the negative coil terminal on the reverse solenoid. If not battery voltage, then check the solenoid coil bus bar connections. **>STOP**
 - c) Check the voltage across the reverse solenoid coil.
 - i) If battery voltage, then the reverse solenoid is bad. **>STOP**
 - ii) If not battery voltage, check the control wiring and directional switch. **>STOP**

REVERSE CONTACTS

1. Connect the test light across the normally closed contacts of the forward solenoid (see figure 3-33).
2. Depress the accelerator pedal fully.
 - a) If the light is on, then the forward solenoid is bad. **>STOP**
3. Connect the test light across the normally open contacts of the reverse solenoid.
4. Depress the accelerator pedal fully.
 - a) If the light is on, then the reverse solenoid is bad. **>STOP**
5. If the light did not come on, then check all power wiring for opens. **>STOP**

SECTION 3

REVERSE ONLY

1. Place the directional switch in neutral.
2. Depress the accelerator pedal. Move the directional switch to forward.
 - a) If the forward solenoid clicks, then go to 'FORWARD CONTACTS'.
 - b) If the forward solenoid does not click, check voltage from battery positive to the negative coil terminal on the forward solenoid. If not battery voltage, then check the solenoid coil bus bar connections. **>STOP**
 - c) Check voltage across forward solenoid coil.
 - i) If battery voltage, then the forward solenoid is bad. **>STOP**
 - ii) If not battery voltage, then check the wiring and directional switch. **>STOP**

FORWARD CONTACTS

1. Connect the test light across the normally closed contacts of the reverse solenoid (see figure 3-33).
2. Depress the accelerator pedal fully.
 - a) If the light is on then the reverse solenoid is bad. **>STOP**
3. Connect the test light across the normally open contacts of the forward solenoid.
4. Depress the accelerator pedal fully.
5. If the light is on then the forward solenoid is bad. **>STOP**
6. If light DID NOT come on then check all power wiring for opens. **>STOP**

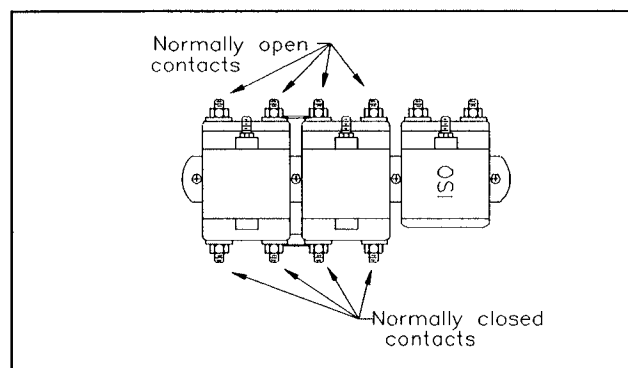
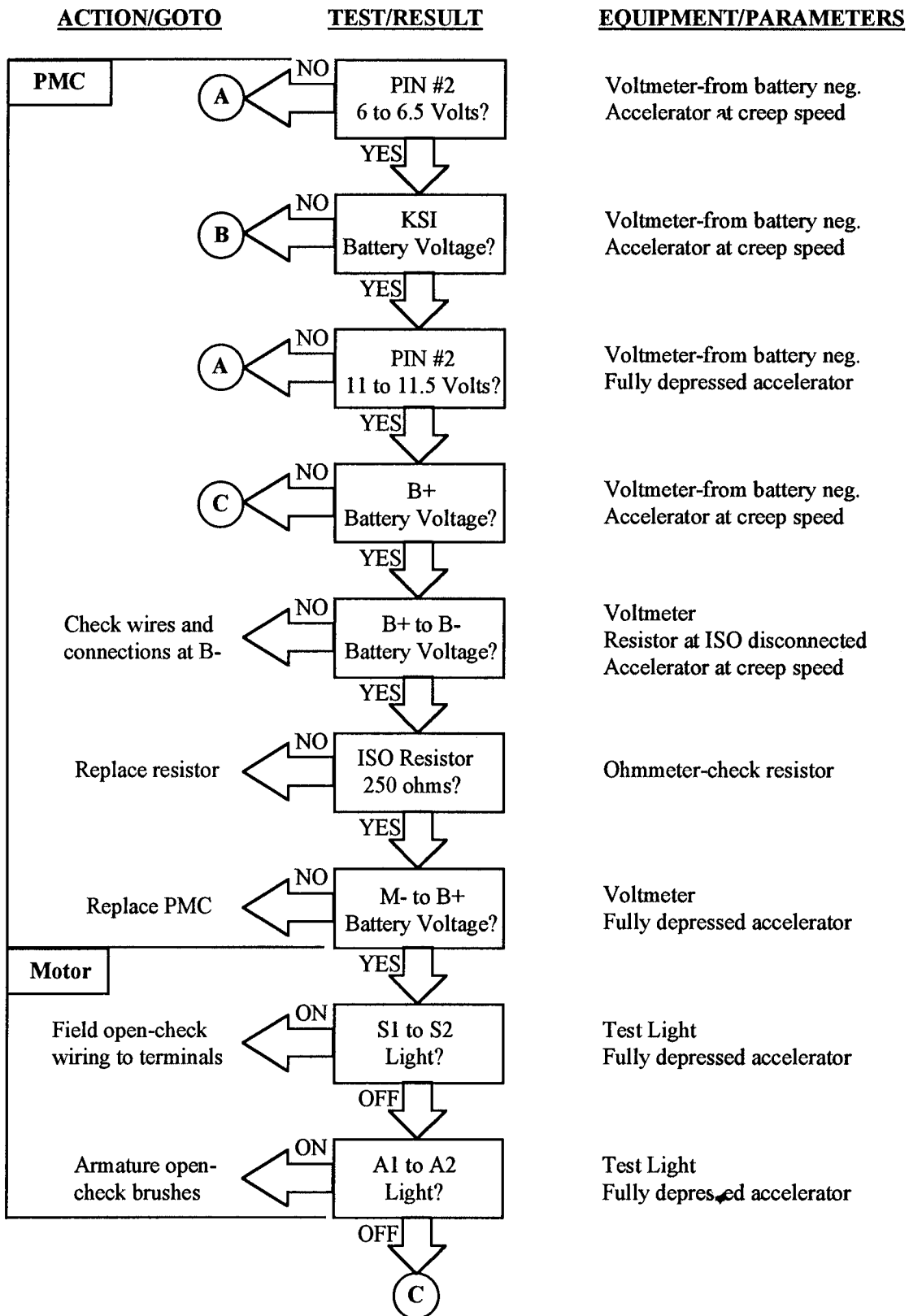

Figure 3-33

If you reached this point without a solution then you may have an unanticipated problem or have made an error during testing.

Electrical Troubleshooting Flow Chart



Electrical Troubleshooting Flow Chart

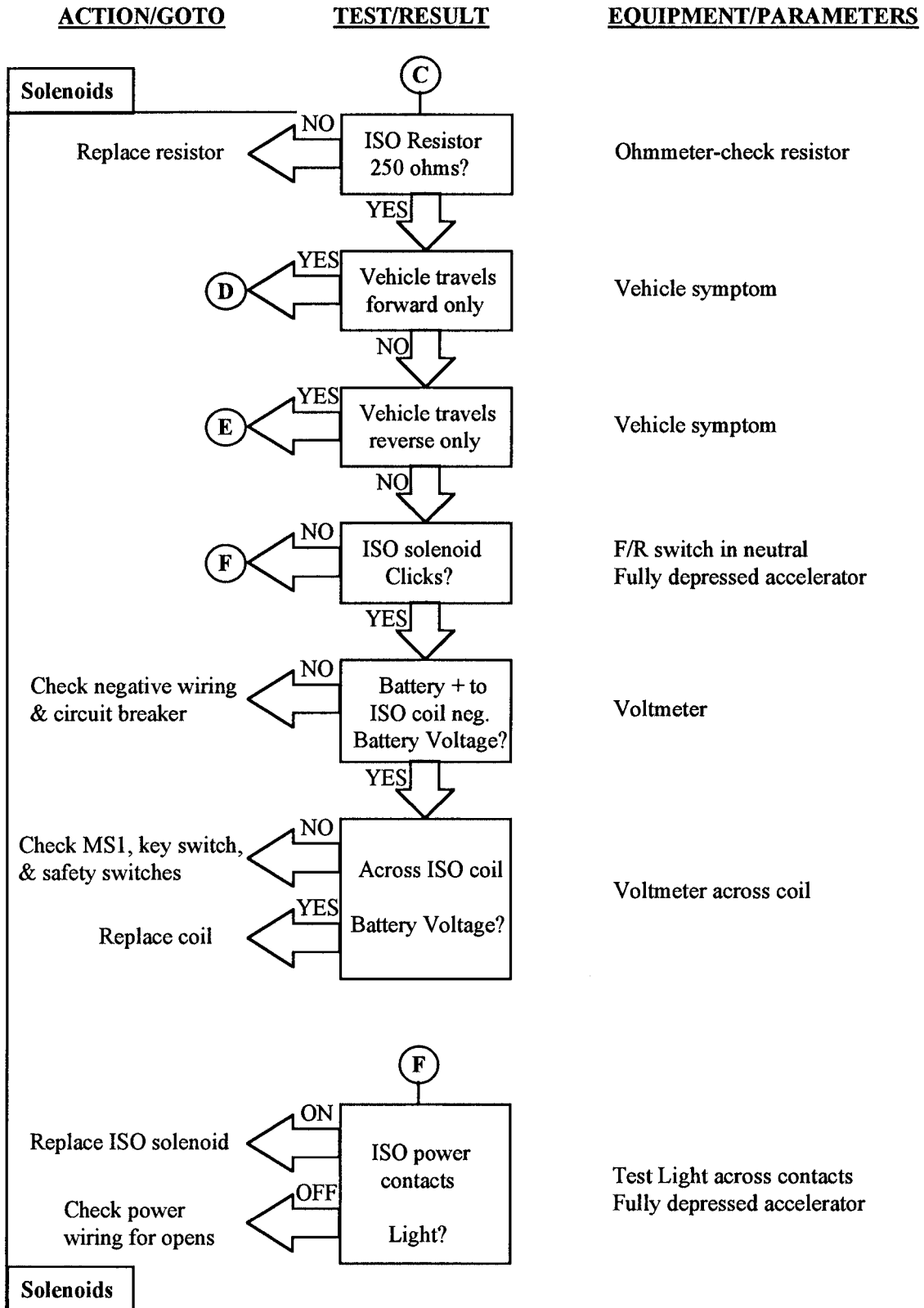

Electrical Troubleshooting Flow Chart

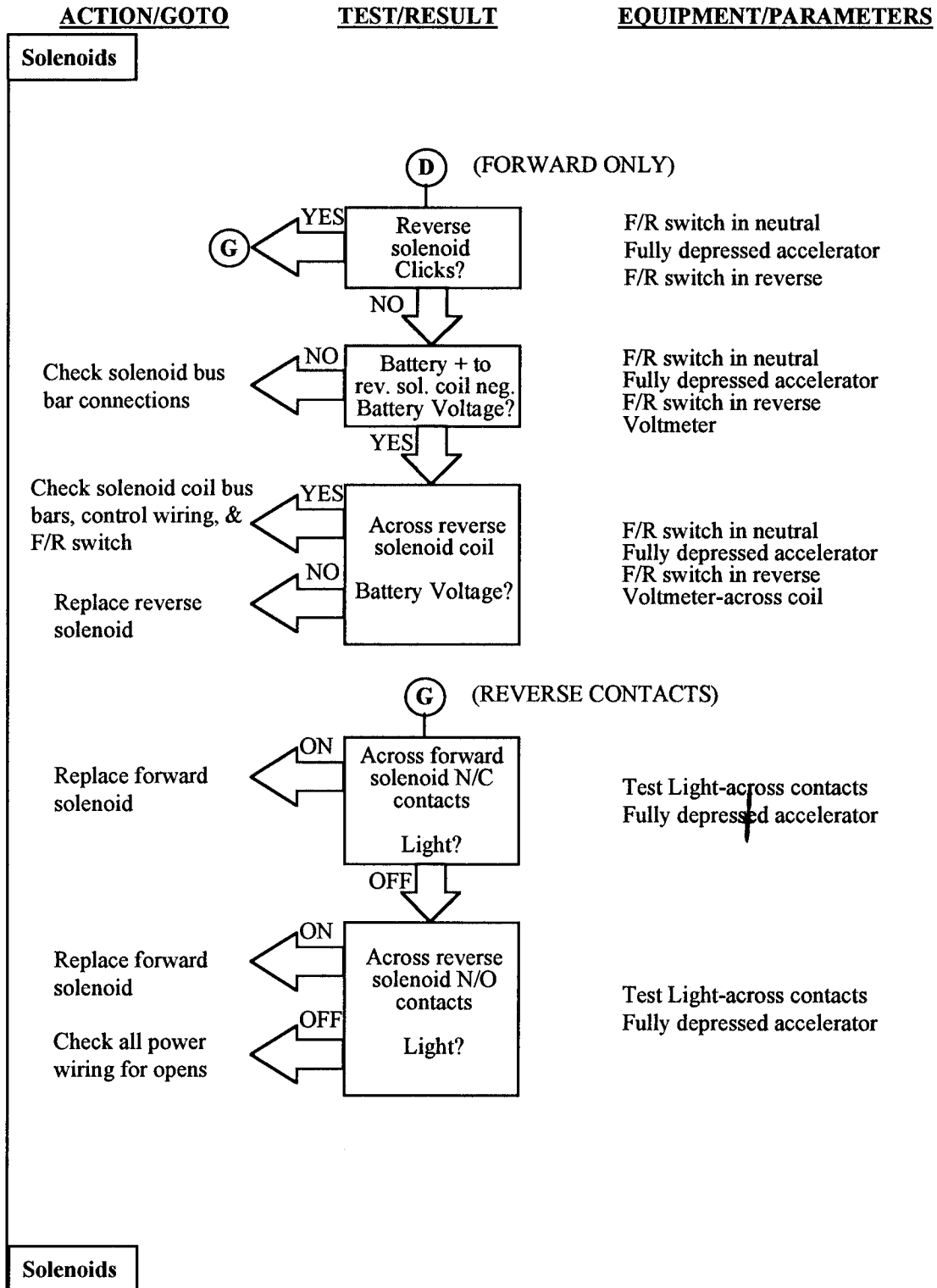

Electrical Troubleshooting Flow Chart

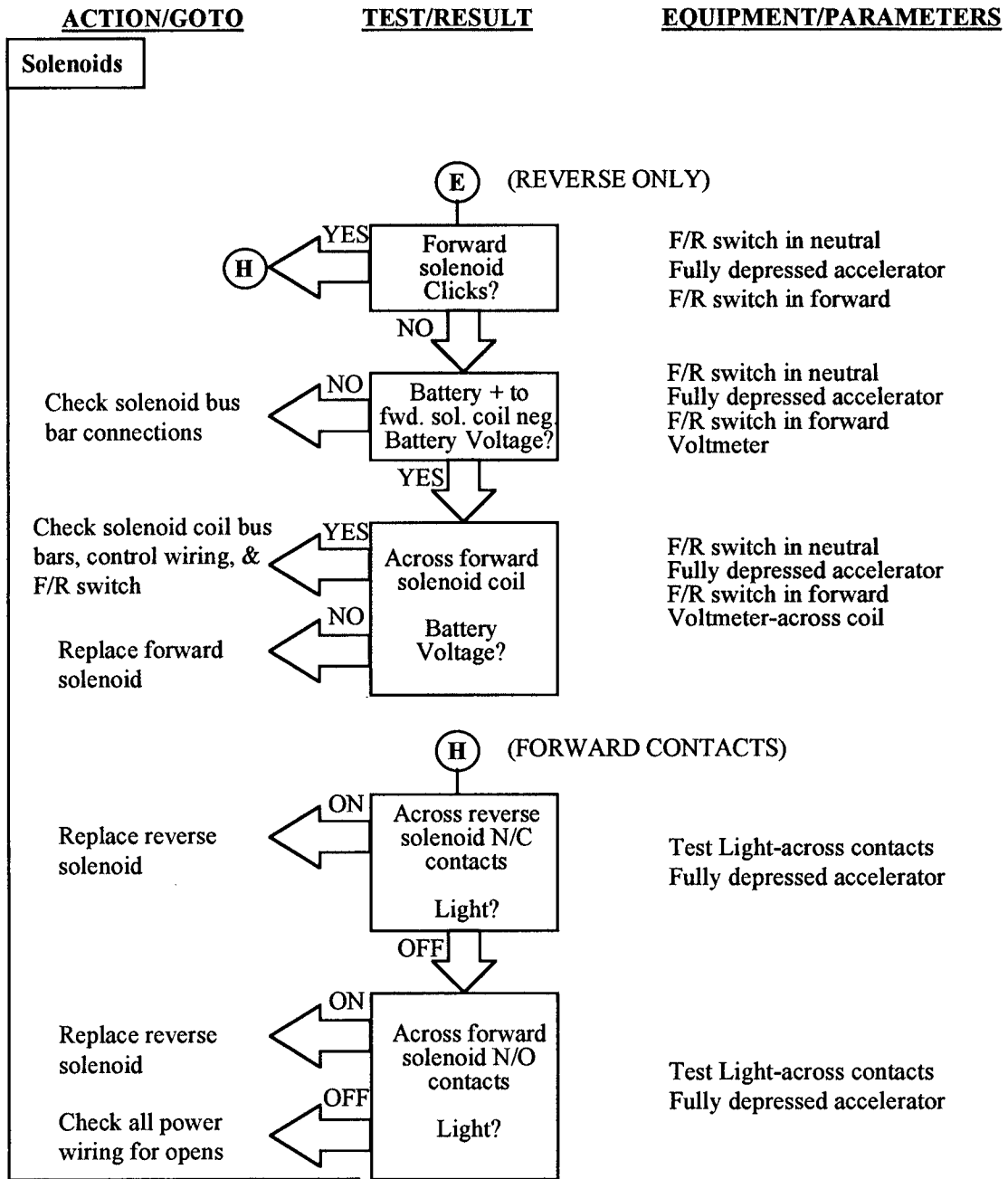

Electrical Troubleshooting Flow Chart

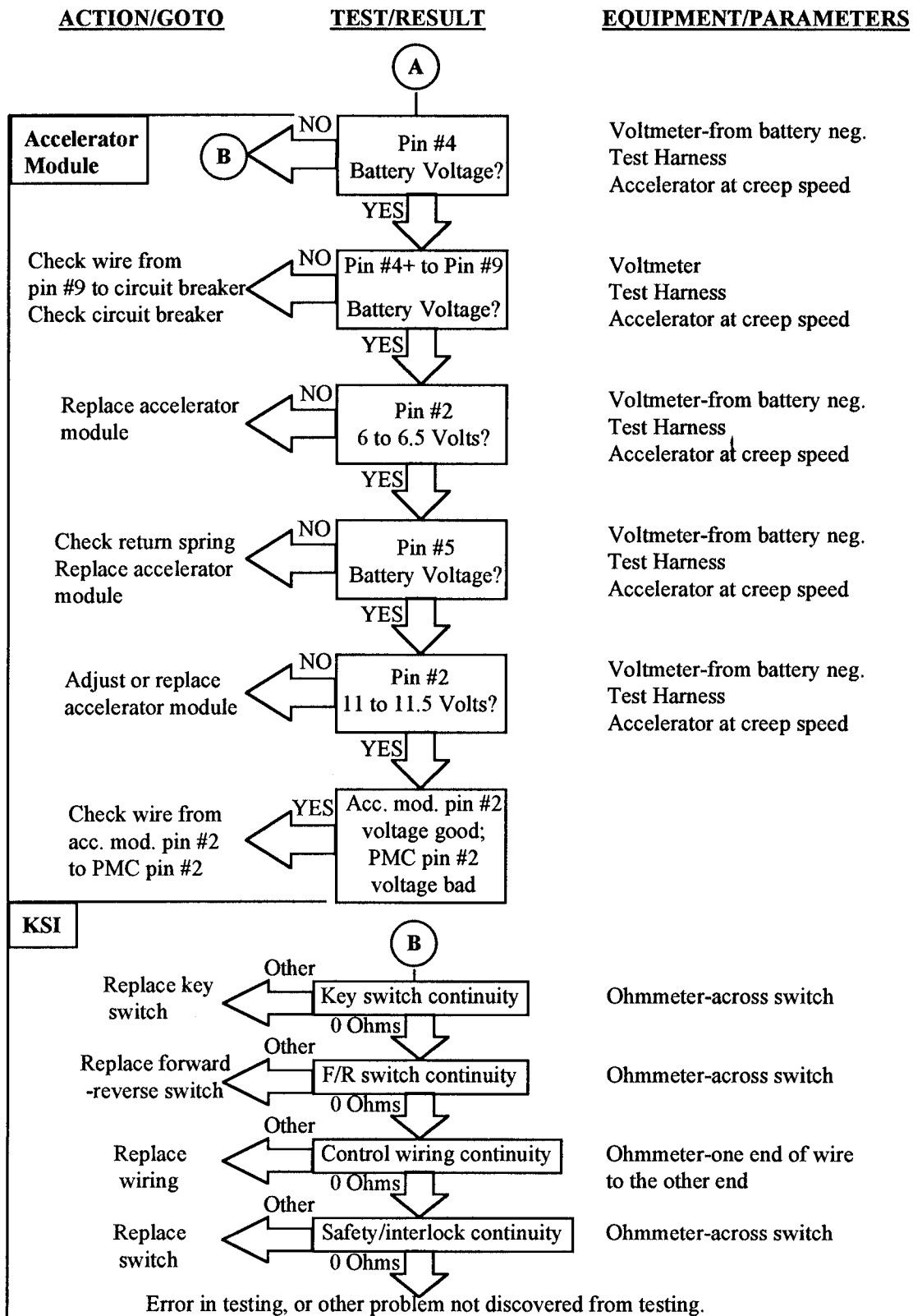

SECTION 3

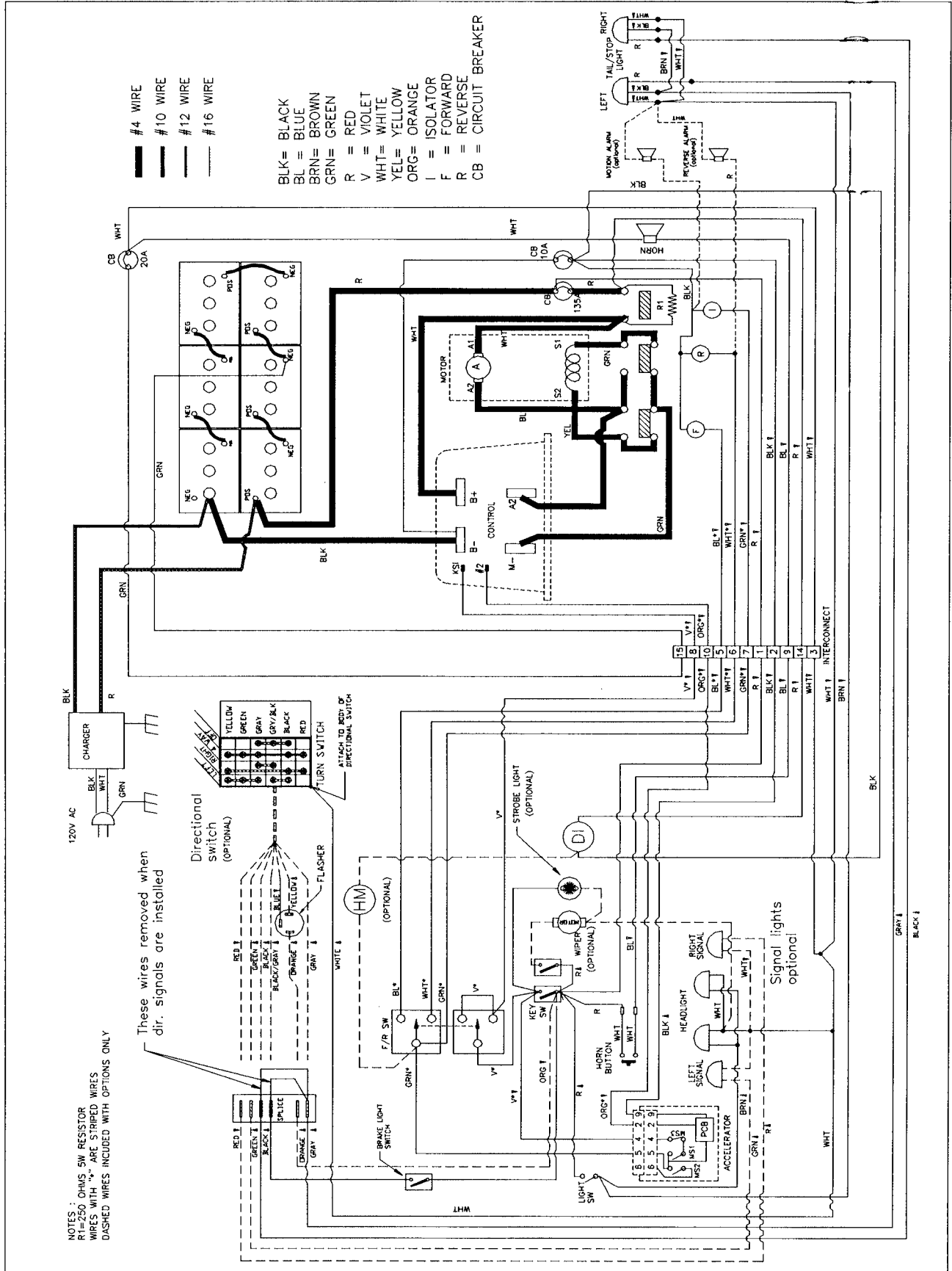

Electrical Wiring Diagram

Charging System

The model B 2-10 uses a 36 volt built-in charger as standard equipment. See the Illustrated Parts List for replaceable parts and part numbers.

If the charger is not properly charging the batteries, use the following guidelines and procedures to determine the cause of the failure.

LESTER CHARGER TROUBLESHOOTING

Standard:

Built-in charger: 79-305-05-model 07460 type 36LC25-8ET

Optional:

Portable charger:	79-305-20-model 7710-32 type 36LC25-8ET
Built-in charger (40 amp):	79-306-25-model 13745 type 36LC40-8ET
Portable charger (40 amp):	79-306-20-model 09475-31 type 36LC40-8ET
Built-in export charger:	79-304-65-model 11860 type 36LC25-8ET
Portable export charger:	79-304-60-model 7030-01 type 36LC25-8ET
Portable export charger (40 amp):	79-306-90-model 12315-31 type 36LC40-8ET

⚠ WARNING

HIGH VOLTAGE and HIGH DC CURRENT. If you do not understand any part of these tests, refer testing to a qualified electrical mechanic.

⚠ WARNING

Prevent the truck from moving. Before performing maintenance on any vehicle, disconnect the batteries, set the parking brake, and block the wheels

START:

1. Disconnect the charger from the AC and DC source.
2. If this is a built in charger then remove the charger from the truck.
3. Remove the charger cover.

⚠ WARNING

High voltage may be stored in the capacitor. Discharge the capacitor with an insulated screwdriver before proceeding. Do not touch the screwdriver blade while discharging the capacitor.

1. Inspect all internal wiring and repair as necessary.
2. Inspect the fuse link and replace if bad.
3. Test the diodes.
 - a) Use a VOM set at R x 100 ohms scale.
 - b) Remove one lead from one diode (see figure 3-34).
 - c) Connect the test leads across one diode. The meter should either deflect to the right side of scale or not at all.
 - d) Reverse the polarity on the diode test leads. You should get the opposite reading of the previous test.
 - e) If you get the same reading in both polarities, then the diode is bad.
 - f) Repeat the test on the other diode.
 - g) Reconnect the lead removed in step 6B to the diode.

NOTE *It is recommended to replace the diodes as a set.*

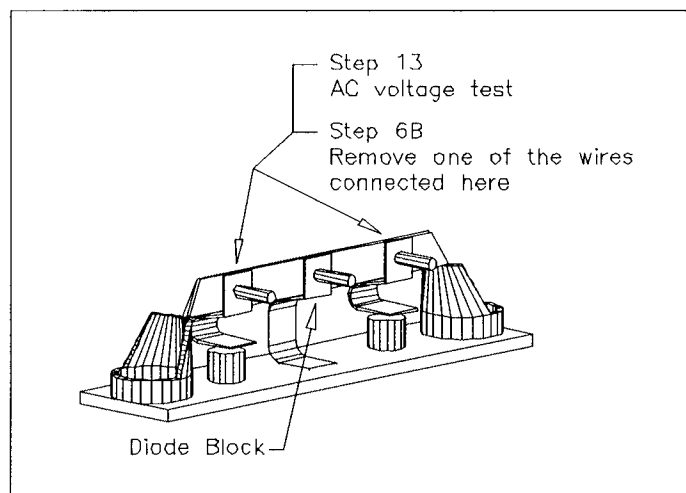

Figure 3-34

7. Test the capacitor.

- a) Use an analog VOM set at its highest ohms scale. Preferably R x 10,000.

⚠ WARNING

High voltage may be stored in the capacitor. Discharge the capacitor with an insulated screwdriver. Do not touch screwdriver blade while discharging capacitor.

- b) Disconnect one lead from the capacitor.
- c) Connect the test leads across the capacitor. The needle should deflect to low ohms reading and then slowly return to infinity (left side of scale). If the needle stays on low ohms reading or does not deflect at all, then the capacitor is bad.

NOTE *Check the capacitor in both polarities*

- d) Reconnect the lead removed in step 7B.

8. Reconnect the DC source only.

9. Measure DC voltage from the diode block (+) to the fuse assembly (-).

- a) If you do not get battery voltage, then the wiring to the battery is bad.

10. If the charger is equipped with an ammeter, then check the continuity across the meter.

- a) If you do not get 0 ohms, then the meter is bad.

⚠ WARNING

Electrical shock hazard! After next step there will be un-insulated high voltage in the charger.

⚠ WARNING

The charger must be grounded! The green wire from the AC cord must be electrically attached to the charger cabinet.

11. Reconnect the AC source.

- a) Measure AC input voltage at 1/4" spade connectors on timer (see figure 3-35, terminals 1 and 2).
- b) If not at approximate charger AC voltage listed on the charger spec. plate, then AC input is bad.

Possible AC input problems:

SECTION 3

- Wiring to AC cord.
- AC cord or plug.
- House wiring or circuit breaker. To test, plug a known to be good light into the wall receptacle.

12. Measure AC output voltage at timer (see figure 3-35, terminals 2 and 3).

- a) If it is not the same as the input voltage, then the timer is bad.

13. Measure AC voltage at diodes (see figure 3-34).

- a) If not 75-90 VAC (on 25 amp chargers only), then the transformer is bad.

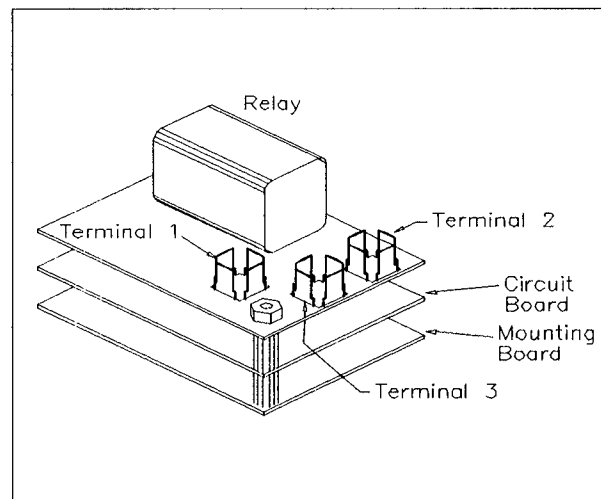

Figure 3-35

ILLUSTRATED PARTS LIST



SECTION 4

FRONT AXLE

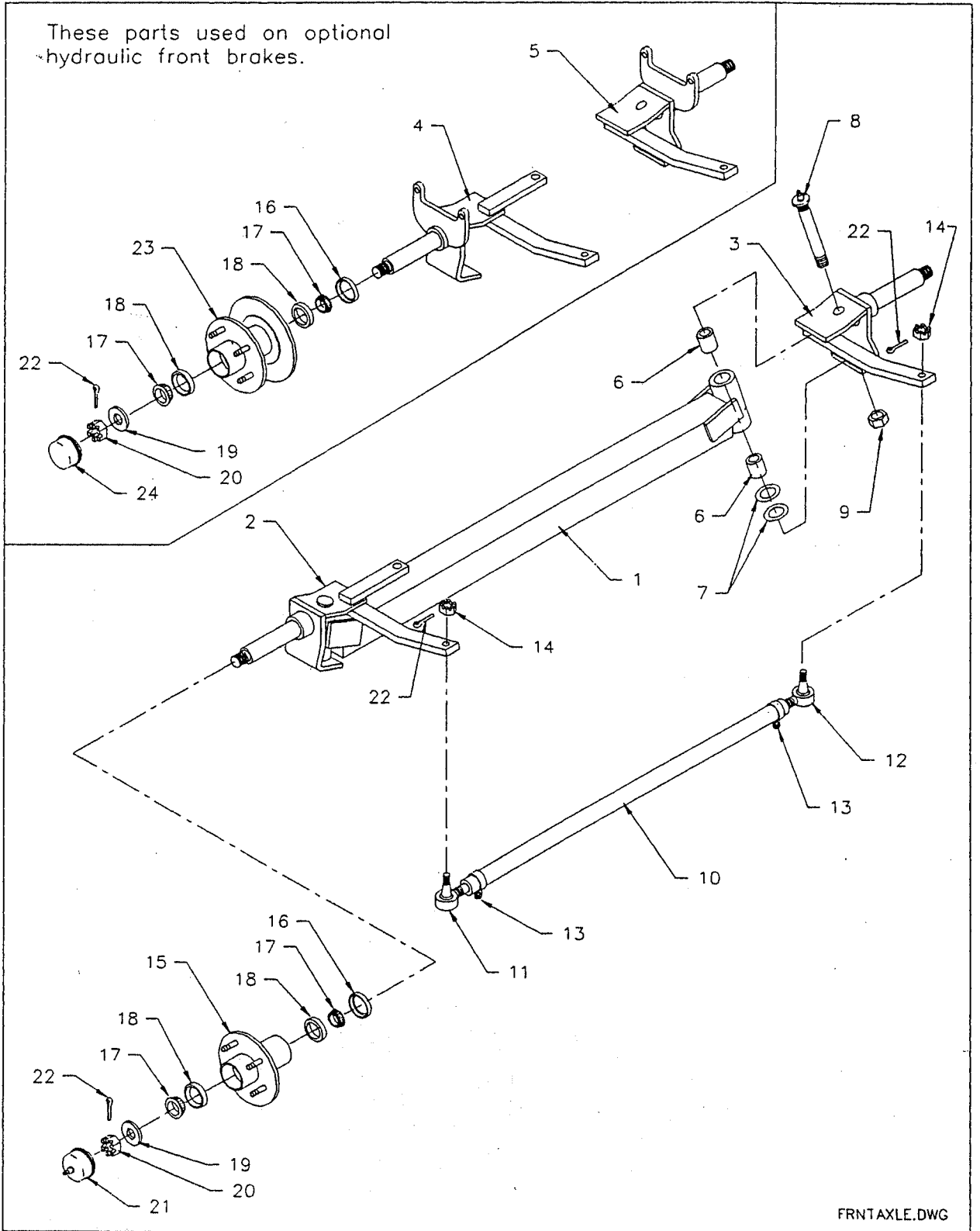

FRONT AXLE			
Item No.	Part No.	Description	Qty
1	15-210-00	Front Axle	1
2	14-210-98	Axle Yoke, Left	1
3	14-210-99	Axle Yoke, Right	1
4	14-210-88	Axle Yoke, Hydraulic Disc, Left (optional)	1
5	14-210-89	Axle Yoke, Hydraulic Disc, Right (optional)	1
6	32-240-55	Bushing, Metal Backed Teflon, 5/8"	4
7	97-180-55	Thrust Washer, Metal Backed Teflon, 5/8"	4
8	21-020-15	King Pin, 5/8" x 1-1/4", w/fitting	2
9	88-189-81	Locknut, 5/8NC	2
10	18-041-00	Steering Sleeve, 22-1/2"	1
11	86-501-98	Ball Joint, Left	1
12	86-501-99	Ball Joint, Right	1
13	86-510-00	Ball Joint Clamp	2
14	88-159-85	Nut, Slotted, 1/2NF	2
15	12-124-00	Hub, 5 Stud, 1" Bearing (includes #16,17,18)	2
16	45-338-00	Seal, 1-1/4" ID	2
17	80-017-00	Bearing, Tapered, 1" ID	2
18	80-103-00	Race, Tapered Bearing	2
19	88-228-61	Washer, 3/4" SAE	2
20	88-239-85	Nut, Slotted, 3/4NF	2
21	92-104-00	Dust Cap, w/fitting	2
22	88-527-11	Cotter Pin, 1/8" x 1"	4
23	12-158-10	Hub, 5 Stud, 1" Bearing, w/Disc (includes #16,17,18)	2
24	92-104-01	Dust Cap	2

15-210-60 Hydraulic Front Axle

SECTION 4

FRONT SUSPENSION

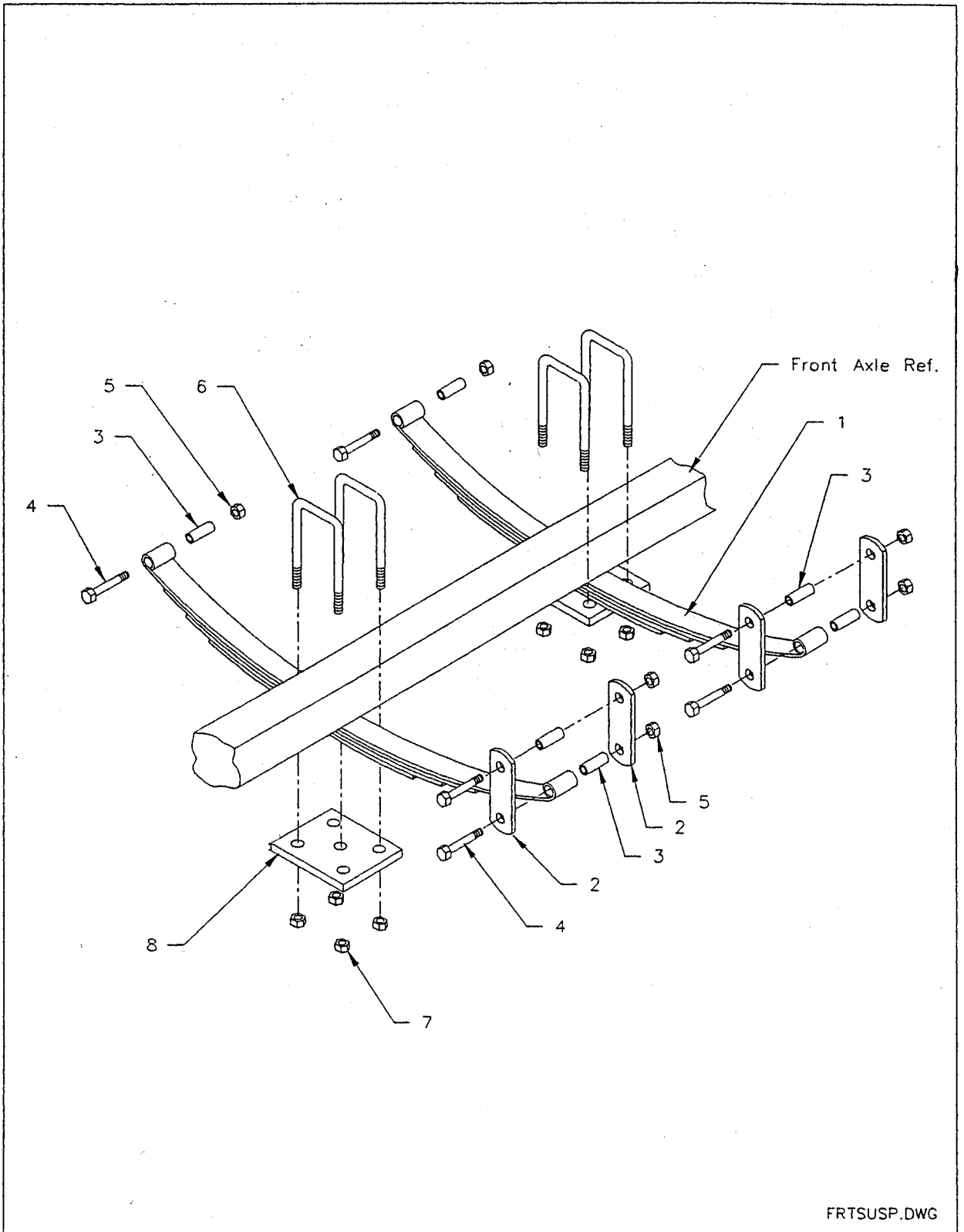

FRTSUSP.DWG

FRONT SUSPENSION			
Item No.	Part No.	Description	Qty
1	85-512-10	Leaf Spring, 1-3/4" x 27-3/8"	2
2	16-870-10	Spring Link	4
3	32-213-00	Bushing, 3/4" OD x 1.656" Long	6
4	96-248-00	Bolt, 9/16NF x 3"	12
5	88-169-82	Locknut, 9/16NF, Grade C	12
6	96-123-00	U-Bolt, 3/8NC x 2"	4
7	88-109-81	Locknut, 3/8NC	8
8	16-865-02	Spring Plate	2

SECTION 4

FRONT SHOCKS (optional)

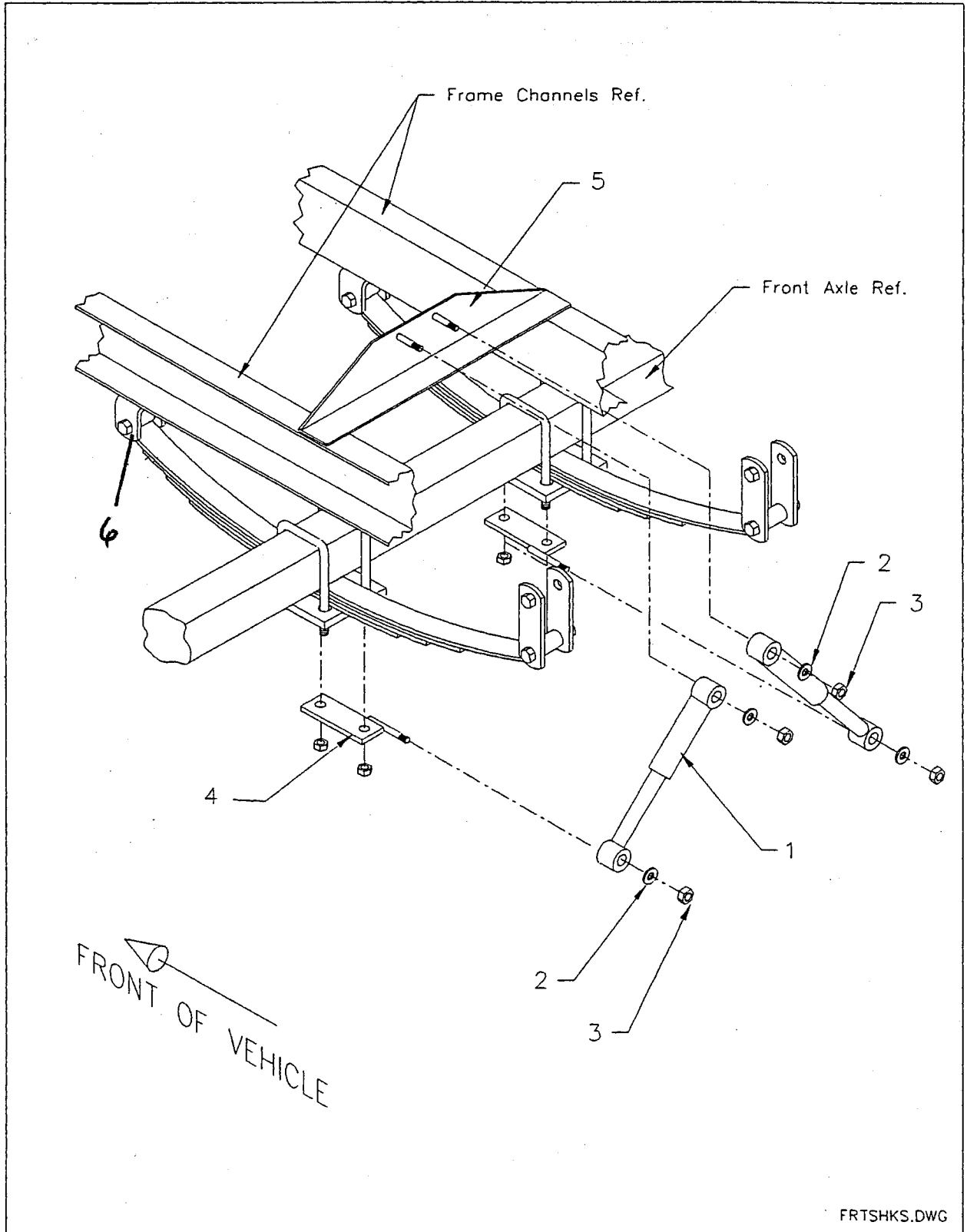

FRONT SHOCKS (optional)			
Item No.	Part No.	Description	Qty
1	86-602-00	Shock Absorber	2
2	88-128-60	Washer, 7/16	4
3	88-129-81	Locknut, 7/16NC	4
4	86-602-13	Lower Shock Mount	2
5	86-602-25	Upper Shock Mount (bolt on)	1
--	86-602-61	Kit, Front Shocks (includes #1,2,3,4,5)	1

6 85-499-00 LEAF SPRING EYE

SECTION 4

STEERING

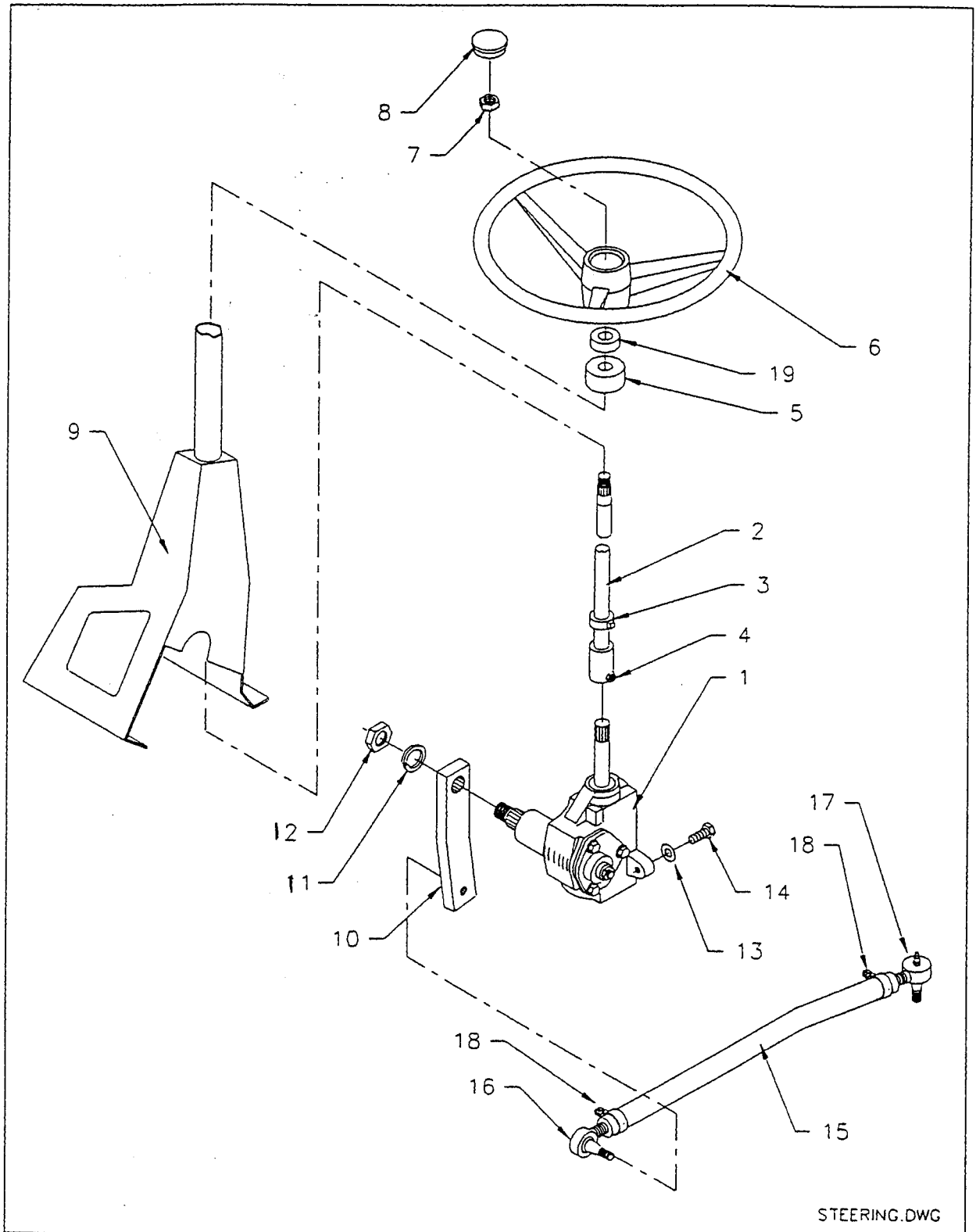

STEERING.DWG

STEERING			
Item No.	Part No.	Description	Qty
1	18-308-21	Steering Gear	1
2	21-031-33	Steering Shaft, 17.938" Long <i>20-031-13</i>	1
3	17-110-00	Collar, 3/4" Shaft	1
4	88-080-04	Bolt, 5/16NC x 3/8" Hex Hd	1
5	80-400-10	Sealed Bearing, 3/4"	1
6	19-011-20	Steering Wheel	1
7	88-199-82	Jam Nut, 5/8NF	1
8	19-011-25	Cover, Steering Wheel	1
9	00-210-17	Steering Column Weldment	1
10	18-111-30	Pitman Arm	1
11	88-268-62	Lock Washer, 7/8"	1
12	88-279-82	Jam Nut, 7/8NF	1
13	88-128-62	Lock Washer, 7/16"	3
14	88-120-15	Bolt, 7/16NC x 1" Hex Hd	3
15	18-057-11	Sleeve, Drag Link	1
16	86-501-98	Ball Joint, Left	1
17	86-501-99	Ball Joint, Right	1
18	86-510-00	Clamp, Ball Joint	2
19	97-200-00	Dust Washer	1

SECTION 4

STEERING GEAR

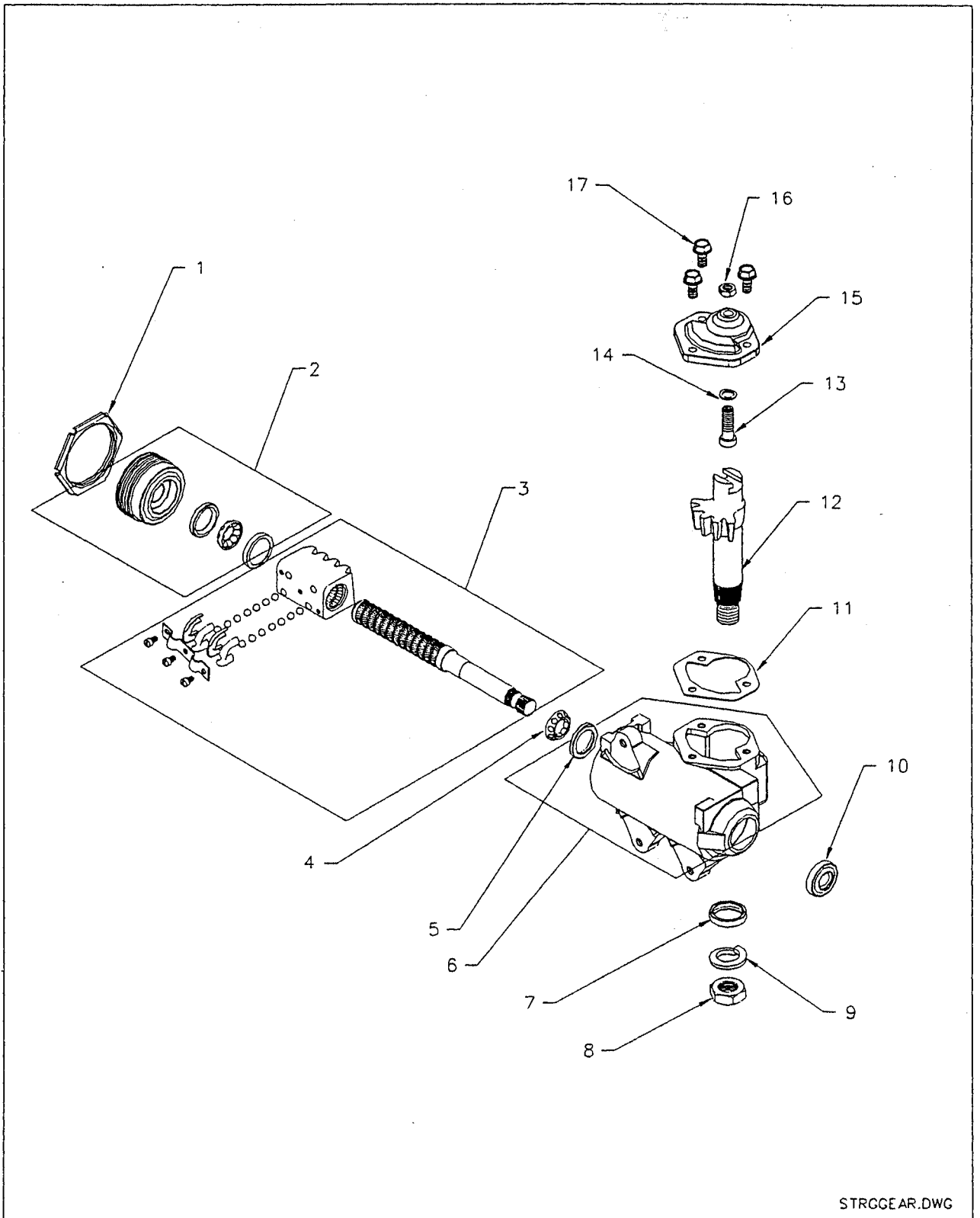

STRGGEAR.DWG

STEERING GEAR (18-308-21)			
Item No.	Part No.	Description	Qty
1	18-308-70	Locknut, Worm Bearing Adjuster	1
2	18-308-71	Adjuster Assembly	1
3	18-308-72	Worm Assembly	1
4	18-308-23	Upper Worm Bearing	1
5	18-308-22	Upper Worm Bearing Race	1
6	18-308-77	Housing, Steering Gear	1
7	18-308-78	Seal, Pitman Shaft	1
8	18-308-80	Nut, Pitman Shaft	1
9	18-308-81	Lock Washer, Pitman Shaft	1
10	18-308-79	Seal, Worm Shaft	1
11	18-308-82	Gasket, Side Cover	1
12	18-308-76	Pitman Shaft	1
13	18-308-75	Lash Adjuster	1
14	18-308-85	Shim Kit	1
15	18-308-84	Side Cover	1
16	18-308-86	Nut, Lash Adjuster	1
17	18-308-83	Bolt, Side Cover	3

Saginaw 18-308-21

Fits all vehicles if that's the type of steering gear installed in the vehicle. There is a difference in the shaft.

SECTION 4

PARK BRAKE

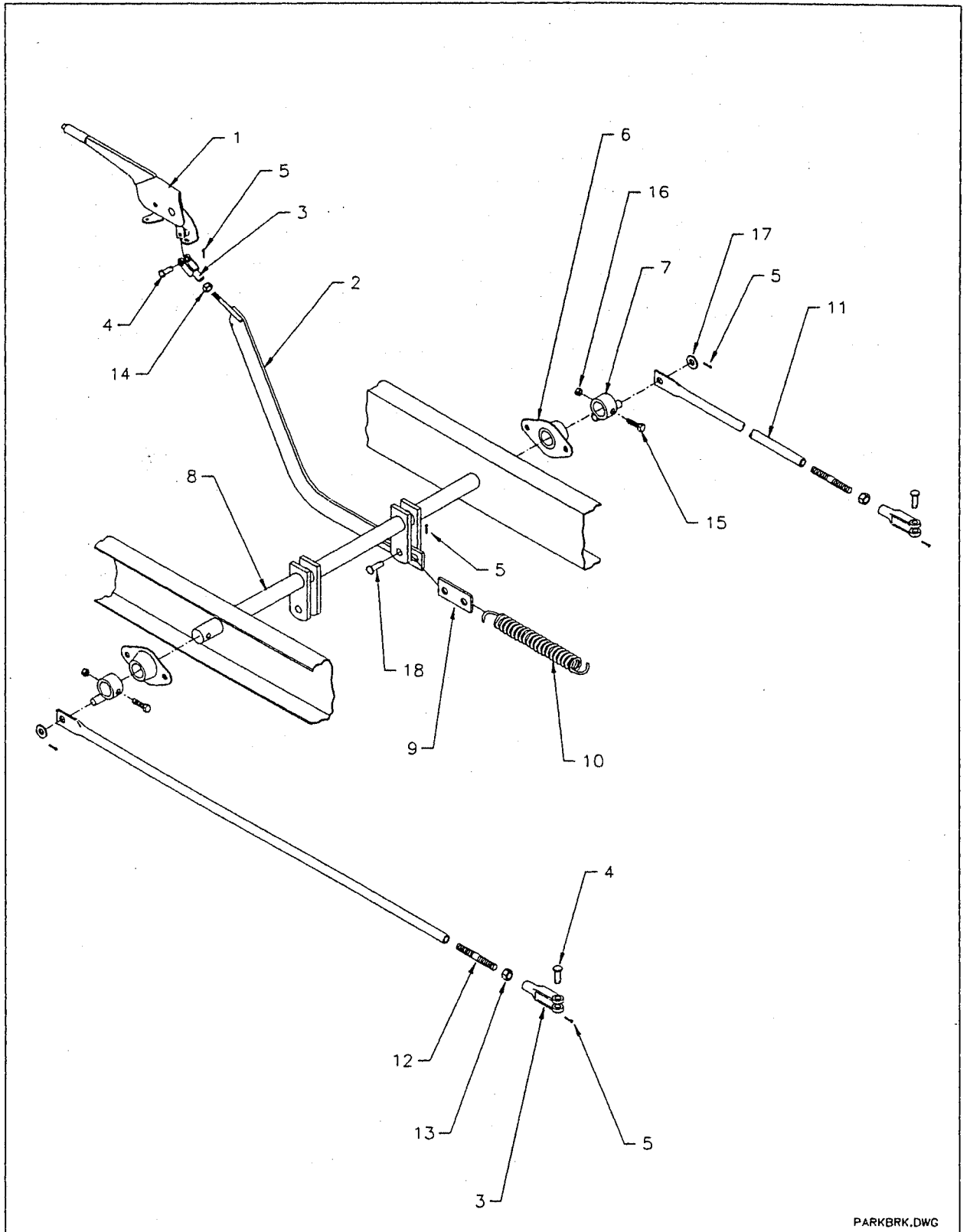

PARKBRK.DWG

PARK BRAKE			
Item No.	Part No.	Description	Qty
1	51-344-10	Lever, Park Brake, w/Tab	1
2	05-210-86	Hand Brake Bar	1
3	96-763-00	Clevis, 5/16"	3
4	96-773-00	Clevis Pin, 5/16" x 1" Long	3
5	88-517-09	Cotter Pin, 3/32" x 3/4" Long	6
6	80-410-20	Bearing, Brake Shaft	2
7	00-210-05	Rotor, Brake Rod	2
8	06-210-11	Brake Cross Shaft	1
9	02-210-72	Spring Link	1
10	85-295-00	Spring, Extension	1
11	02-210-01	Park Brake Rod	2
12	96-343-00	Screw, Brake Adjusting	2
13	88-099-80	Nut, 5/16NF	2
14	88-089-80	Nut, 5/16NC	1
15	88-060-14	Bolt, 1/4NC x 1-1/2" Hex Hd	2
16	88-069-81	Nut, 1/4NC	2
17	88-108-60	Washer, 3/8" Cut	2
18	96-772-00	Clevis Pin, 3/8" x 1" Long	1

SECTION 4

DEADMAN SEAT BRAKE (optional)

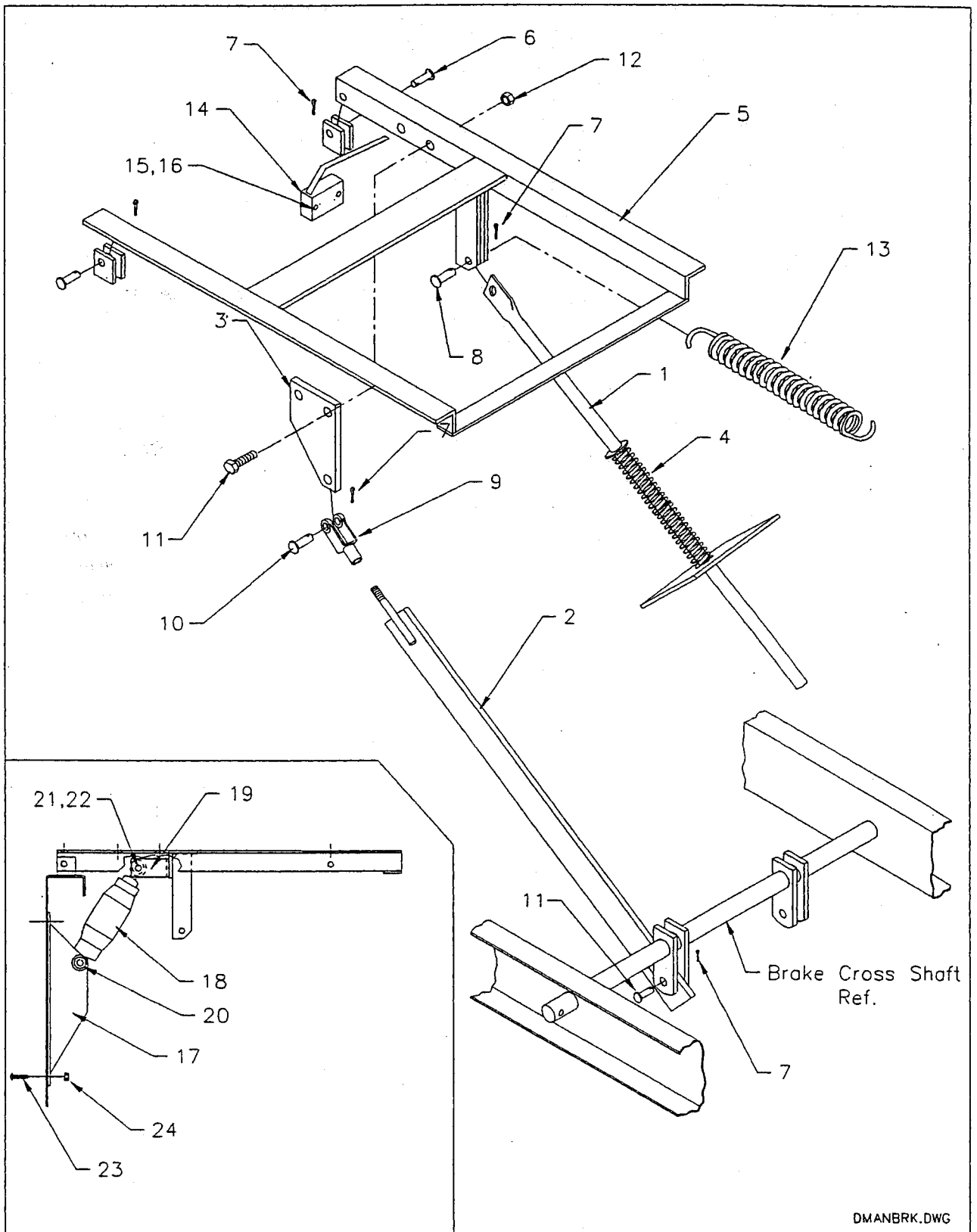

DEADMAN SEAT BRAKE			
Item No.	Part No.	Description	Qty
1	00-210-24	Brake Push Rod	1
2	02-210-50	Seat Brake Link	1
3	02-210-60	Seat Link Arm	1
4	85-123-00	Spring, Deadman Seat	1
5	00-210-03	Seat Frame	1
6	96-773-00	Clevis Pin, 5/16" x 1" Long	2
7	88-517-09	Cotter Pin, 3/32" x 3/4" Long	5
8	96-773-10	Clevis Pin, 5/16" x 1-1/8" Long	1
9	96-762-00	Clevis, 3/8"	1
10	96-772-00	Clevis Pin, 3/8" x 1-1/8" Long	1
11	88-100-09	Bolt, 3/8NC x 3/4" Hex Hd.	2
12	88-109-81	Locknut, 3/8NC	2
13	85-234-00*	Spring, Extension, 1" OD x 5-1/2"	1
14	71-135-01**	Seat Switch	1
15	88-014-13**	Screw, 6-32 x 1-1/4" Round Hd.	2
16	88-019-86**	Locknut, 6-32	2
17	00-210-31	Mount, Seat Shock	1
18	86-007-00	Shock Absorber	1
19	02-210-91	U-Mount, Seat Shock	1
20	32-207-10	Bushing, Rubber, 3/8" x 5/8" x 1" Long	2
21	88-080-15	Bolt, 5/16NC x 1-3/4" Hex Hd	2
22	88-089-81	Locknut, 5/16NC	2
23	88-065-09	Screw, 1/4NC x 3/4 Phillips Truss Hd	2
24	88-069-87	Nut, 1/4NC Keps	2

* This part is used on the standard vehicle without the deadman seat option.

** These parts are standard on all vehicles.

SECTION 4

MASTER CYLINDER & BRAKE LINKAGE

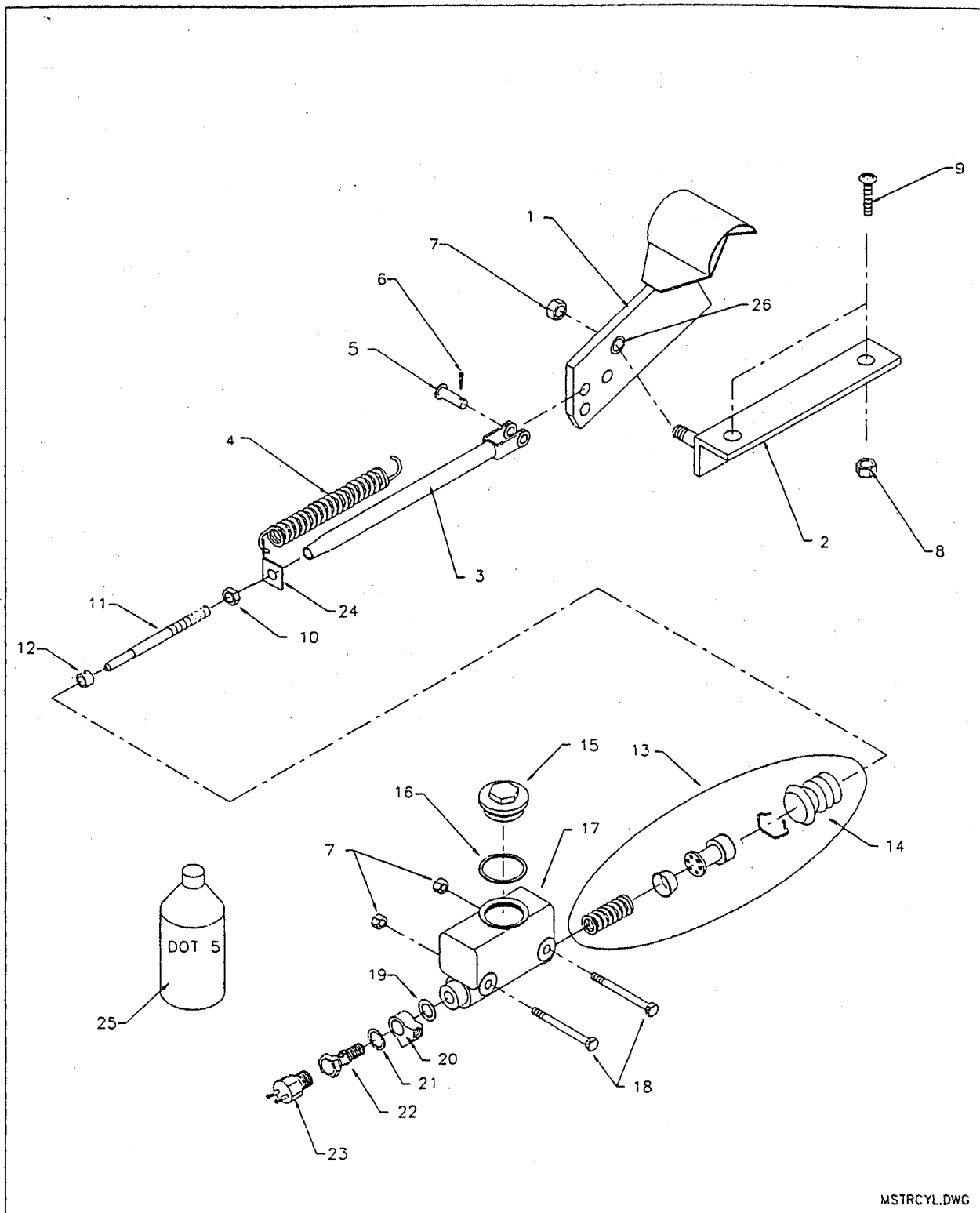

MSTRCYL.DWG

MASTER CYLINDER & BRAKE LINKAGE			
Item No.	Part No.	Description	Qty
1	05-210-97	Brake Pedal	1
2	00-210-21	Mount, Brake Pedal	1
3	00-210-08	Rod, Hydraulic Brake	1
4	85-233-00	Spring, Extension, 1" OD x 5-1/2"	1
5	96-772-00	Clevis Pin, 3/8" x 1"	1
6	88-527-11	Cotter Pin, 1/8" x 1"	1
7	88-109-81	Locknut, 3/8NC	1
8	88-069-81	Locknut, 1/4NC	2
9	88-065-09	Bolt, 1/4NC x 3/4" Phillips Truss Hd	2
10	88-119-80	Nut, 3/8NF	1
11	50-009-00	Rod, Master Cylinder Push	1
12	17-104-00	Collar, 3/8" ID	1
13	99-510-61	Master Cylinder Rebuild Kit	1
14	99-510-51	Rubber Boot	1
15	99-510-52	Cap, Master Cylinder	1
16	99-510-53	Gasket, Master Cylinder Cap	1
17	99-510-02	Master Cylinder (includes: 13, 15, 16)	1
18	88-101-20	Bolt, 3/8NC x 3" Hex Hd, Grade 5	2
19	99-572-00	Washer, Small Dia.	1
20	99-565-00	Y-Fitting	1
21	99-571-00	Washer, Large Dia.	1
22	99-578-00	Bolt, Stop Light	1
23	71-110-00	Switch, Hydraulic Brake Light	1
24	06-210-03	Clip, Spring Anchor	1
25	94-410-00	Brake Fluid, Hydraulic, Dot 5 (12 oz container)	1
26	32-240-40	Bearing, 3/8", Metal Backed Teflon	1

HYDRAULIC BRAKE LINES

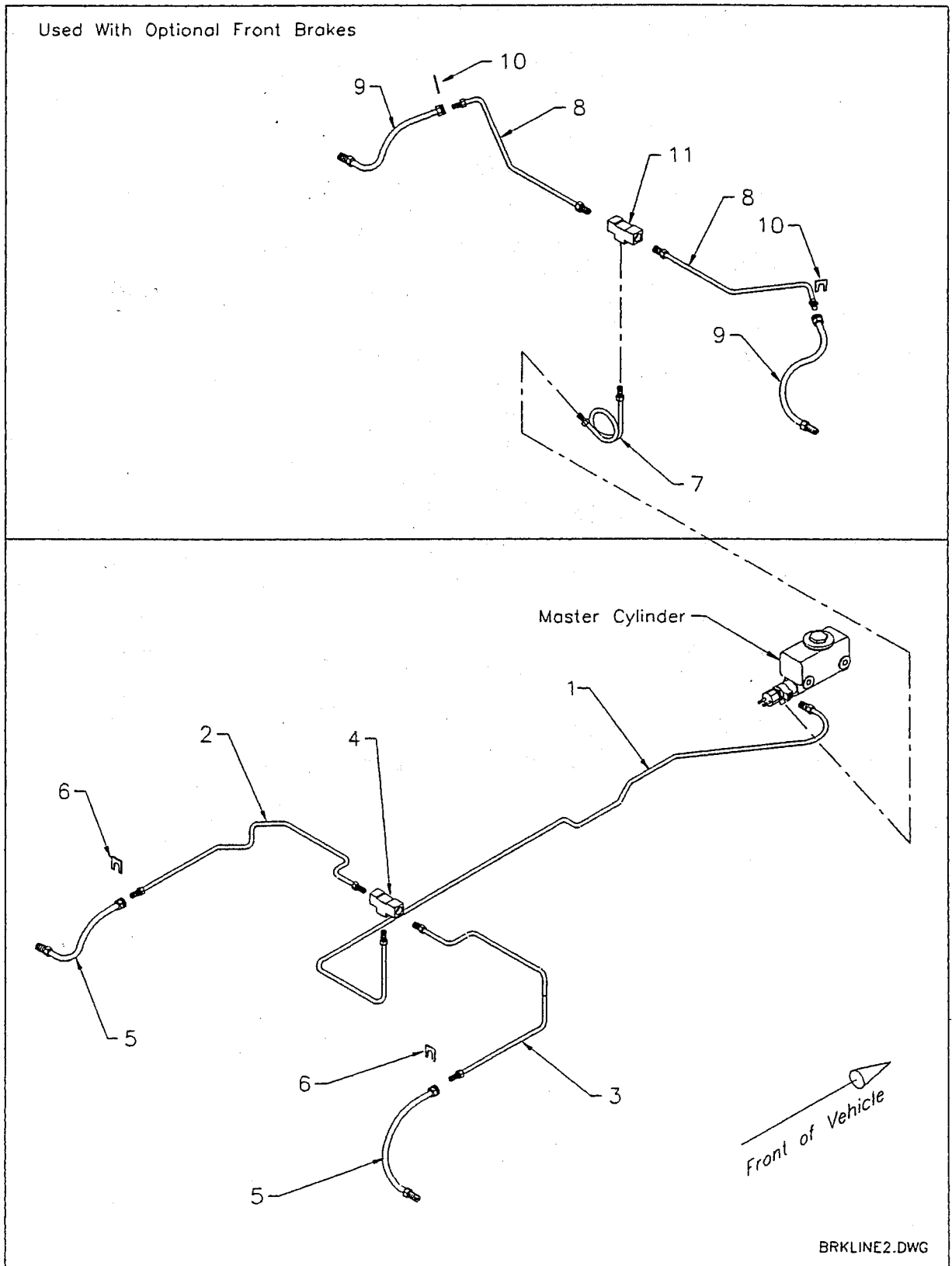

HYDRAULIC BRAKE LINES			
Rear			
Item No.	Part No.	Description	Qty
1	99-607-51	Brake Line, 51 Long	1
2	99-605-55	Brake Line, Left	1
3	99-605-56	Brake Line, Right	1
4	99-564-00	T-Fitting	1
5	99-580-20	Brake Hose	2
6	99-576-00	Clip, Brake Hose	2
Front (optional)			
7	99-607-51	Brake Line, 51 Long	1
8	99-603-53	Brake Line, Front	2
9	99-580-20	Brake Hose	2
10	99-576-00	Clip, Brake Hose	2
11	99-564-00	T-Fitting	1

SECTION 4

FRONT BRAKES (optional)

⚠ WARNING

The brake body mounting nuts can only be used once. If removed they must be replaced.

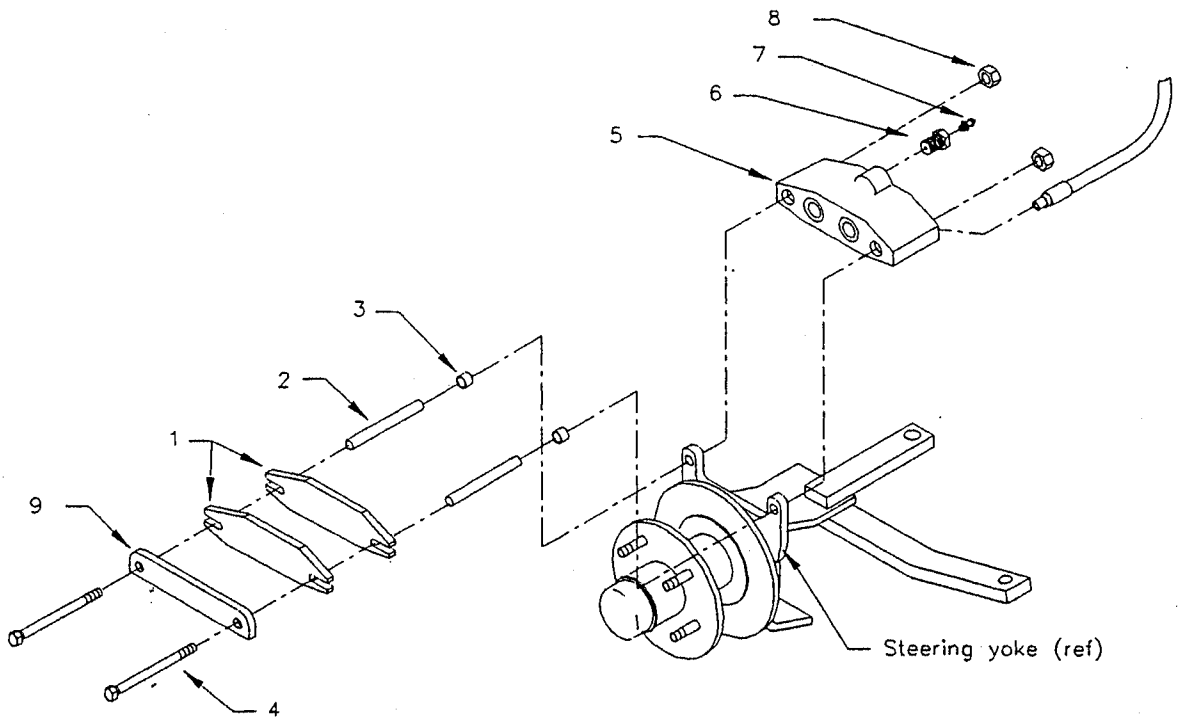

FRNTBRK.DWG

FRONT BRAKES (optional)			
Item No.	Part No.	Description	Qty*
1	41-348-70	Pad, Disc Brake	2
2	41-348-52	Spacer, Disc Brake	2
3	32-240-40	Bushing, Mounting Bracket	2
4	88-067-21	Brake Body Bolt	2
5	41-350-70	Hydraulic Brake Body, Lt or Rt	1
6	99-588-01	Bleeder Fitting	1
7	99-588-00	Bleeder Valve	1
8	88-069-82	Locknut, 1/4NC, Grade 8; DO NOT REUSE!	2
9	41-350-51	Secondary Plate	1

* Quantities are for one brake assembly only. The left brake assembly is shown in the illustration.

SECTION 4

REAR BRAKES

⚠ WARNING

The brake body bolt nuts can only be used once. If removed they must be replaced.

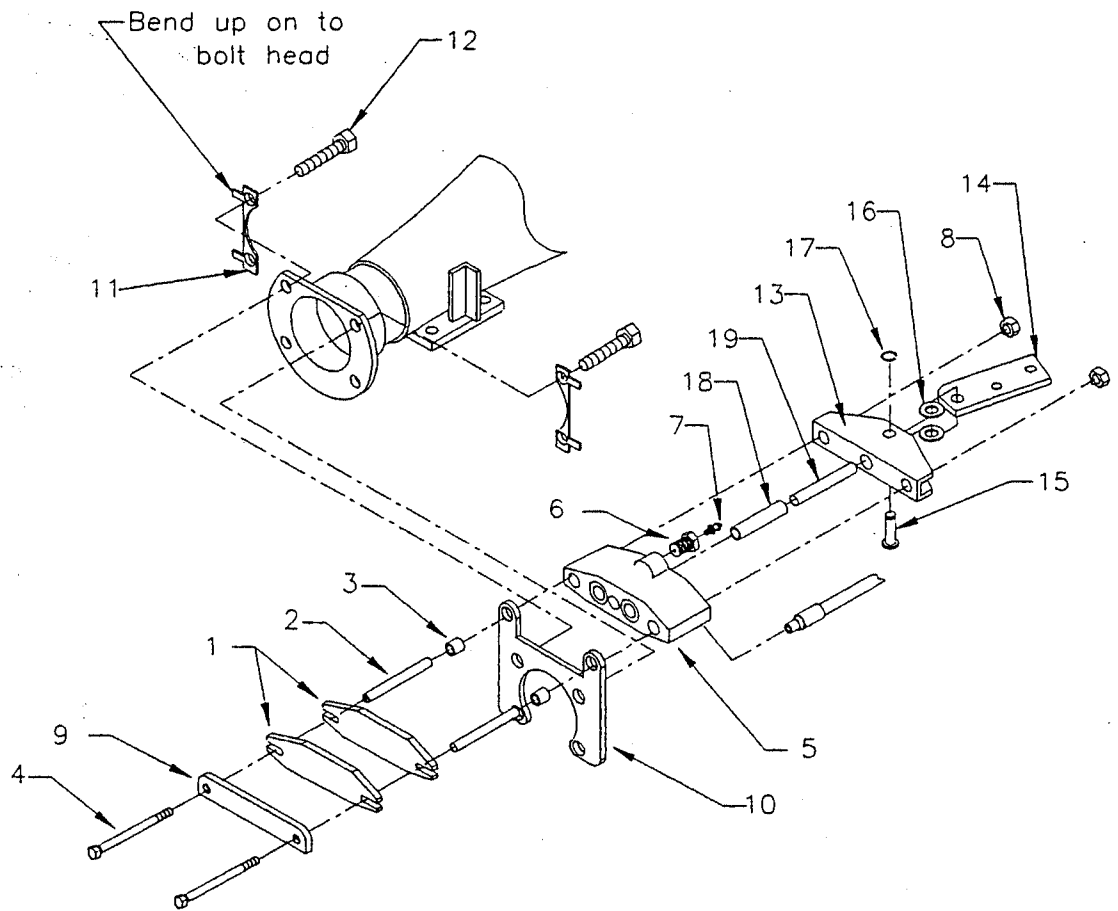

REARBRK.DWG

REAR BRAKES			
Item No.	Part No.	Description	Qty*
	41-350-86	Hydraulic Brake Assembly, Left	1
	41-350-87	Hydraulic Brake Assembly, Right	1
1	41-348-70	Pad, Disc Brake	2
2	41-348-52	Spacer, Disc Brake	2
3	32-240-40	Bushing, Mounting Bracket	2
4	88-067-21	Brake Body Bolt	2
5	41-350-70	Hydraulic Brake Body, Lt or Rt	1
6	99-588-01	Bleeder Fitting	1
7	99-588-00	Bleeder Valve	1
8	88-069-82	Locknut, 1/4NC, Grade 8; DO NOT REUSE!	2
9	41-350-51	Secondary Plate	1
10	41-350-08	Bracket, Hydraulic Disc Brake	1
11	41-350-05	Clip, Bolt Locking	2
12	96-328-00	Bolt, 3/8NC x 5/8", Grade 5	4
13	41-350-12	Bracket, Park Brake	1
14	41-350-53	Arm, Park Brake	1
15	41-350-52	Clevis Pin, Hydraulic Disc Brake	1
16	88-100-00	Washer, .341" ID x .105" Thick	2
17	88-840-11	Retaining Ring, 5/16"	1
18	32-220-03	Bushing, 3/8" OD x 5/16" ID x 1-3/4"	1
19	41-350-56	Pin, Park Brake	1

* Quantities are for one brake assembly only. The left brake assembly is shown in the illustration.

CHARGERS

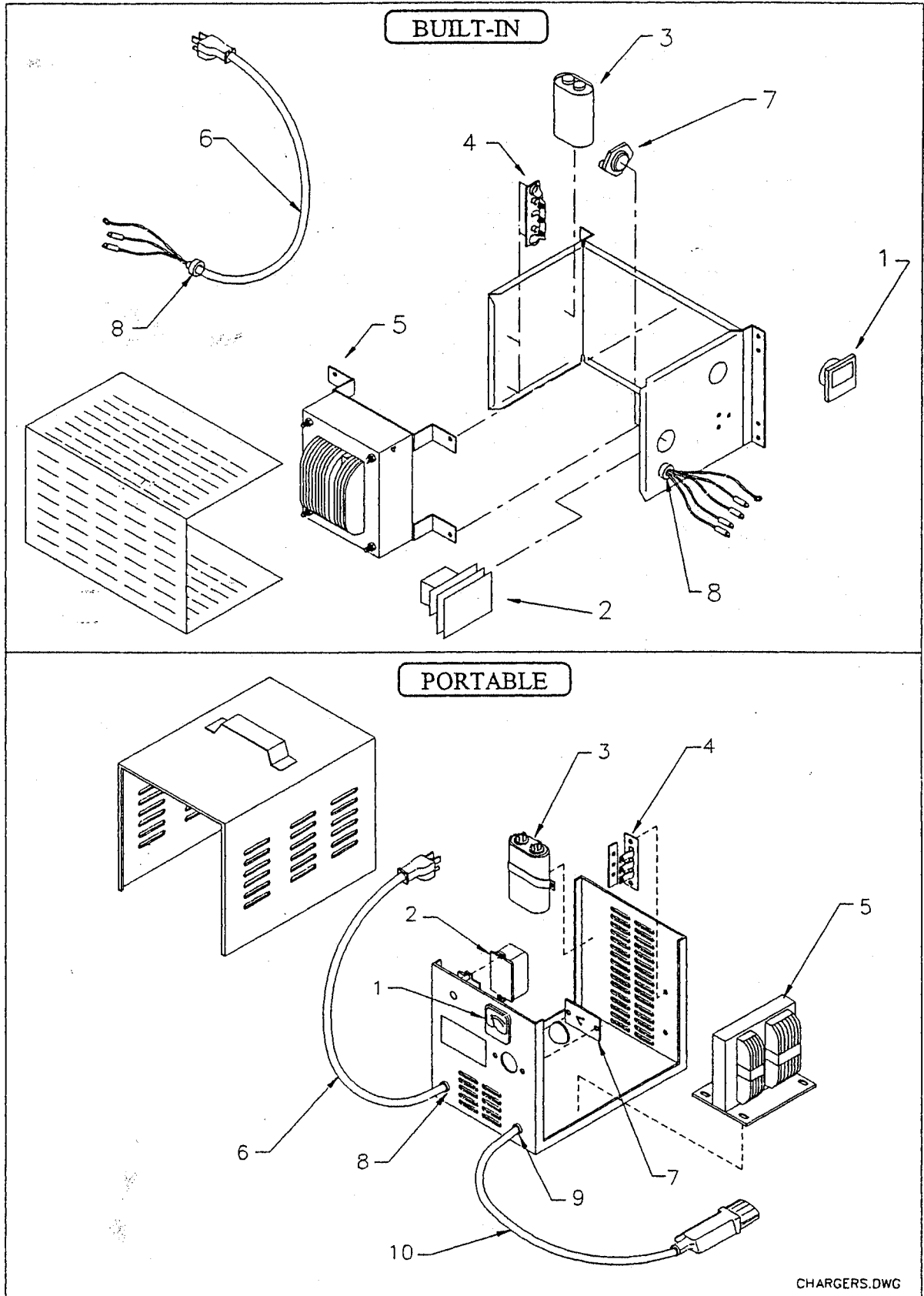

CHARGERS.DWG

CHARGERS (36V 25A)					
Item No.	Description	BUILT-IN	PORTABLE		Qty
Standard	Charger-Complete	79-305-05	79-305-20		1
	Charger Manufacturer I.D. No.:	07460	7710-32		
1	Ammeter	79-851-10	79-851-10		1
2	Timer	79-805-67	79-805-63		1
3	Capacitor	79-902-00	79-902-00		1
4	Heat Sink Assembly with Diodes	79-749-13	79-749-13		1
5	Transformer	79-644-31	79-644-27		1
6	Cordset, AC, w/Plug	79-575-30	79-575-10		1
7	Fuse Assembly	79-831-00	79-831-00		1
8	Bushing, for AC Cordset	79-530-00	79-530-00		1
9	Bushing, for DC Cordset	N.A.	79-530-00		1
10,10a	DC Cord	N.A.	79-566-10,11		1
Not Shown	Harness, Portable Charger	N.A.	75-107-10		1
CHARGERS (36V 40A)					
Optional	Charger-Complete	79-306-25	79-306-20		1
	Charger Manufacturer I.D. No.:	13745	09475-31		
1	Ammeter	79-852-00	79-852-00		1
2	Timer	79-805-67	79-805-63		1
3	Capacitor	79-902-00	79-902-00		1
4	Heat Sink Assembly with Diodes	79-749-10	79-749-10		1
5	Transformer	--	--		
6	Cordset, AC, w/Plug	79-575-30	79-575-10		1
7	Fuse Assembly	79-831-11	79-831-11		1
8	Bushing, for AC Cordset	79-530-00	79-530-00		1
9	Bushing, for DC Cordset	N.A.	79-531-00		1
10	DC Cord w/Shielded Plug	N.A.	79-567-10		1
Not Shown	Harness, Portable Charger	N.A.	--		1
EXPORT CHARGERS					
Optional	Charger-Complete	79-304-65(B.I.)	79-304-60	79-306-90	1
	Charger Mfr. I.D. No.:	11860	7030-01	12315-31	
1	Ammeter	79-851-10	79-851-10	79-852-00	1
2	Timer	79-805-67	79-805-67	79-805-63	1
3	Capacitor	79-902-00	79-902-00	79-902-00	1
4	Heat Sink Assy w/Diodes	79-749-13	79-749-13	79-749-10	1
5	Transformer	79-644-31	79-644-31	--	1
6	Cordset, AC, w/Plug	79-575-30	79-575-30	79-575-10	1
7	Fuse Assembly	79-831-00	79-831-00	79-831-11	1
8	Bushing, for AC Cordset	79-530-00	79-530-00	79-530-00	1
9	Bushing, for DC Cordset	N.A.	79-530-00	79-531-00	1
10,10a	DC Cord	N.A.	79-566-10,11	79-567-10,11	1
Not Shown	Harness, Portable Charger	N.A.	75-107-10	75-107-10	1

SECTION 4

MOTORS

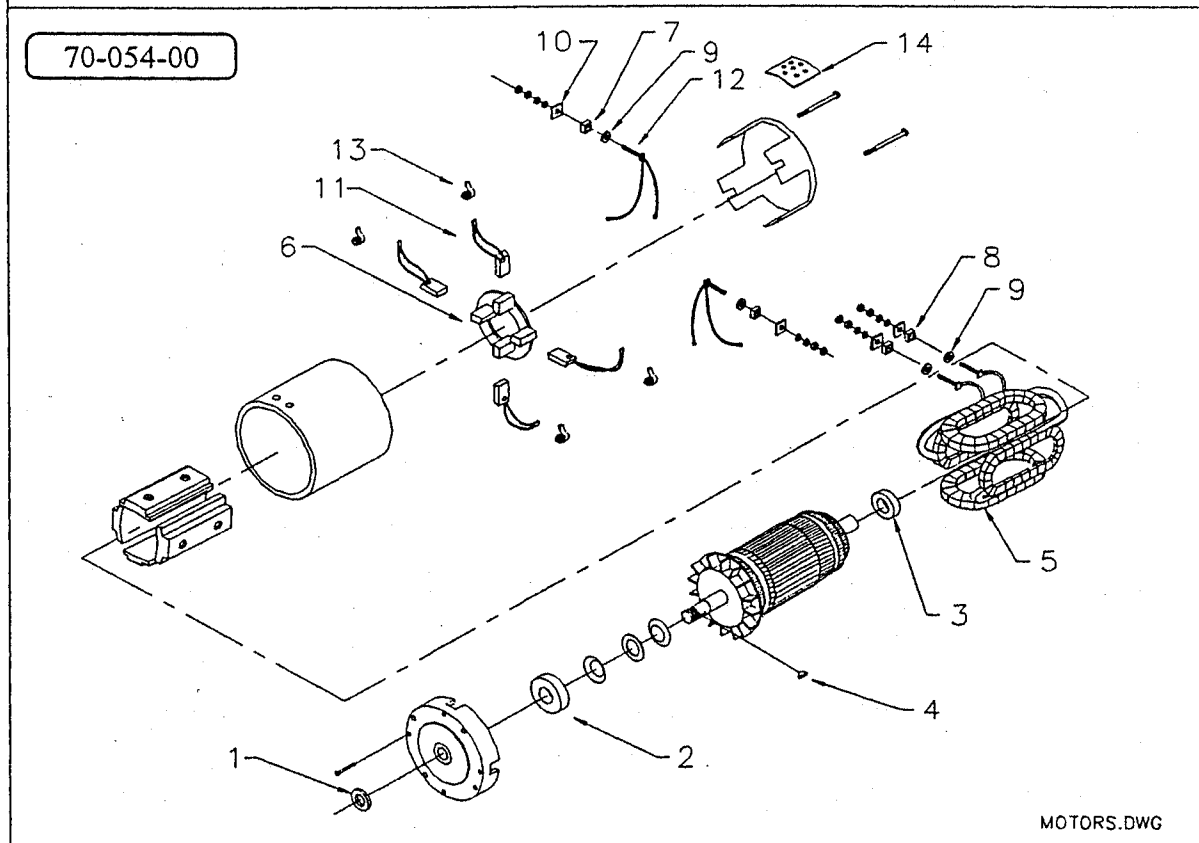
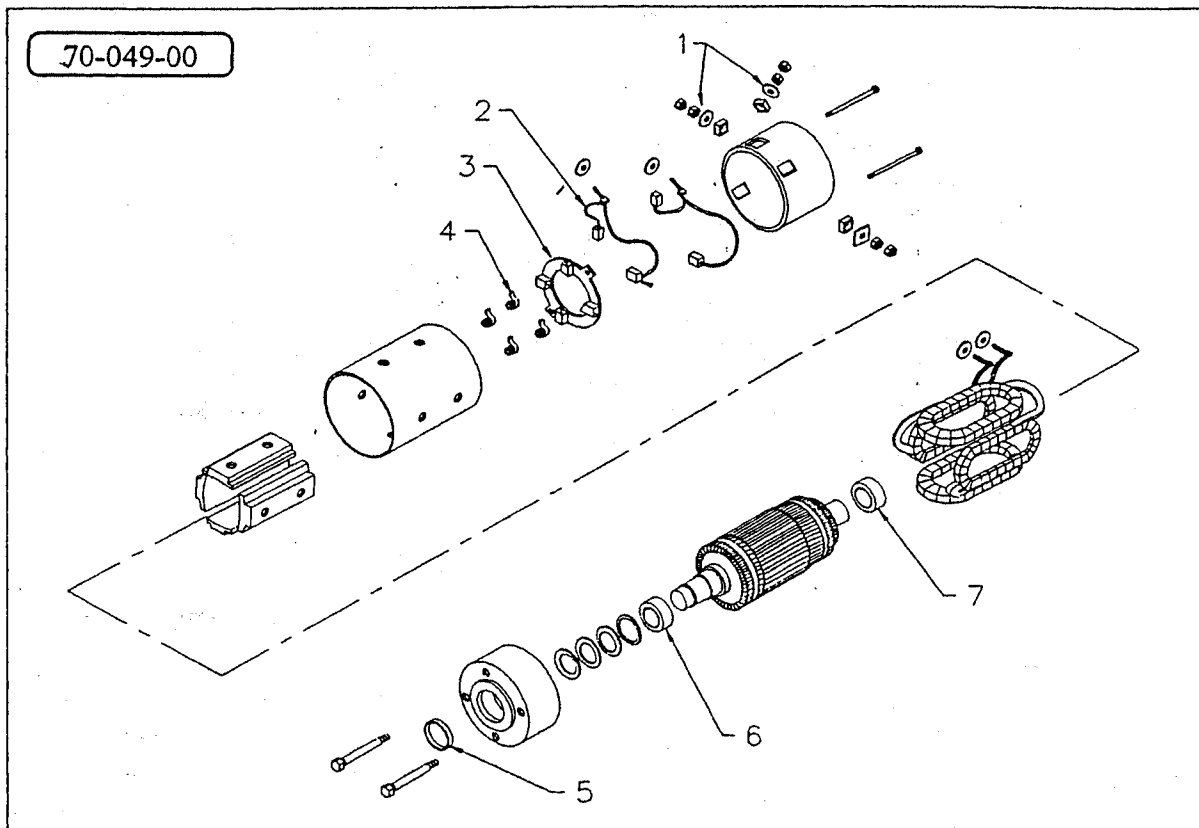

MOTORS.DWG

MOTORS			
Item No.	Part No.	Description	Qty
	70-049-00	Motor-Complete; G.E. #5BC58JBS6110	1
1	70-210-62	Insulator Kit	1
2	70-104-00	Brush Assembly, w/Stud	2
3	70-172-00	Brush Holder Assembly	1
4	85-412-00	Brush Spring	4
5	45-506-00	Oil Seal	1
6	80-504-00	Ball Bearing	1
7	80-209-00	Ball Bearing	1
	70-054-00	Motor-Complete; G.E. #5BC49JB399	1
1	45-508-00	Oil Seal	1
2	80-504-00	Ball Bearing	1
3	80-200-00	Ball Bearing	1
4	97-100-00	Woddruff Key	1
5	70-203-10	Field Coil Set	1
6	70-104-10	Brush Holder (includes #12,13)	1
7	98-622-00	Insulator Bushing	2
8	98-623-00	Insulator Bushing	2
9	97-178-00	Fiber Washer	4
10	97-179-00	Fiber Washer	2
11	70-105-00	Brush	4
12	n/a	Crossover, w/Terminal	2
13	85-412-00	Brush Spring	4
14	30-802-00	Brush Cover	4
	70-210-62	Insulator Kit (includes #7,8,9,10)	2

SECTION 4

MOTORS-cont'd

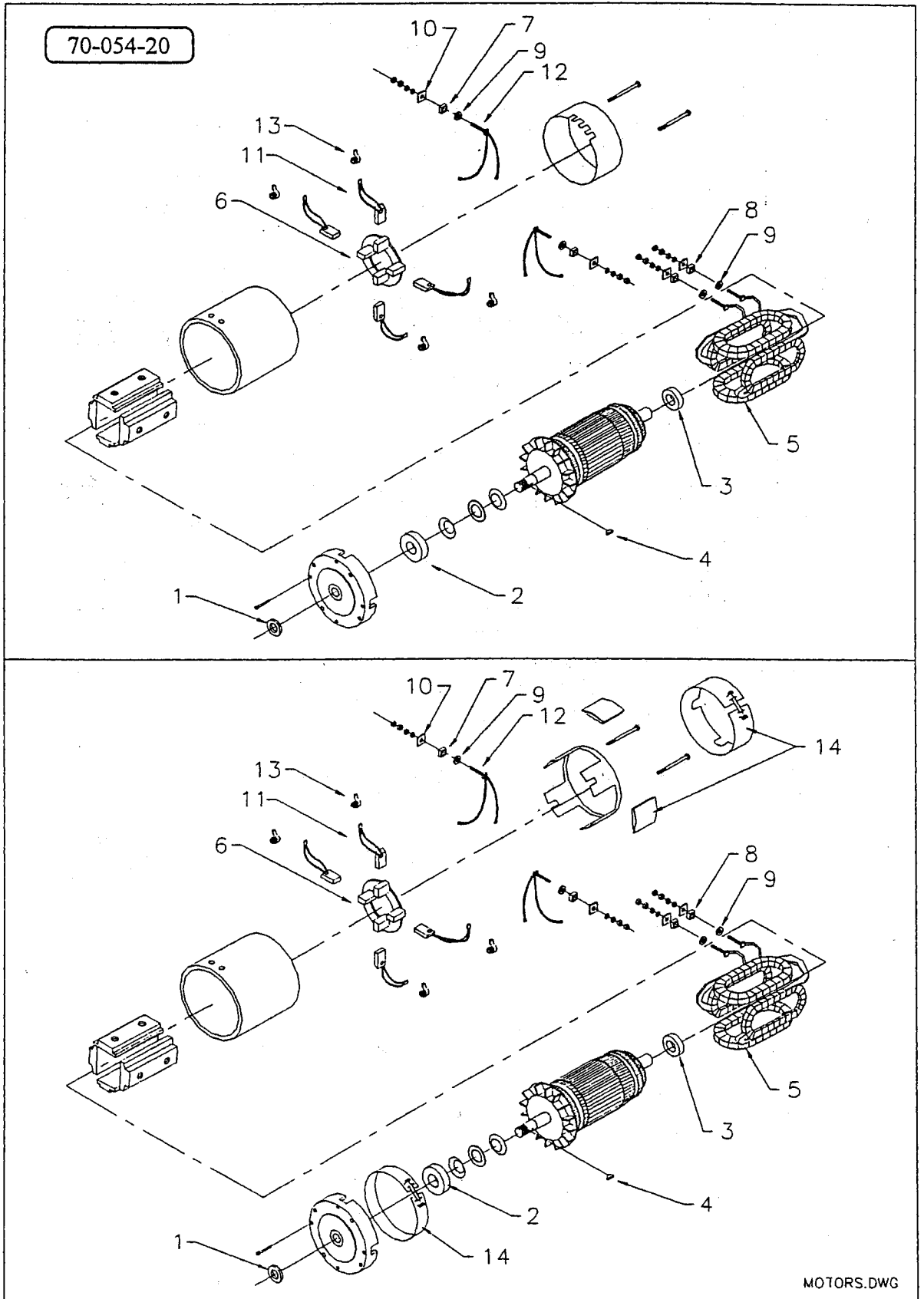

MOTORS-cont'd			
Item No.	Part No.	Description	Qty
	70-054-20	Motor-Complete; G.E. #5BC49JB430; ('EE' rated)	1
1	45-508-00	Oil Seal	1
2	80-504-00	Ball Bearing	1
3	80-200-00	Ball Bearing	1
4	97-100-00	Woddruff Key	1
5	70-203-10	Field Coil Set	1
6	70-104-10	Brush Holder (includes #12,13)	1
7	98-622-00	Insulator Bushing	2
8	98-623-00	Insulator Bushing	2
9	97-178-00	Fiber Washer	4
10	97-179-00	Fiber Washer	2
11	70-105-00	Brush	4
12	n/a	Crossover, w/Terminal	2
13	85-412-00	Brush Spring	4
Alternate Configuration*			
	70-054-00	Motor-Complete; G.E. #5BC49JB399	1
1	45-508-00	Oil Seal	1
2	80-504-00	Ball Bearing	1
3	80-200-00	Ball Bearing	1
4	97-100-00	Woddruff Key	1
5	70-203-10	Field Coil Set	1
6	70-104-10	Brush Holder (includes #12,13)	1
7	98-622-00	Insulator Bushing	2
8	98-623-00	Insulator Bushing	2
9	97-178-00	Fiber Washer	4
10	97-179-00	Fiber Washer	2
11	70-105-00	Brush	4
12	na/	Crossover, w/Terminal	2
13	85-412-00	Brush Spring	4
14	70-054-60	Kit, 'EE' Conversion	1
	70-210-62	Insulator Kit (includes #7,8,9,10)	2

* The alternate configuration uses the 70-054-00 motor, adds the 70-054-60 kit, and creates the 70-054-20 motor.

SECTION 4

BELT DRIVE

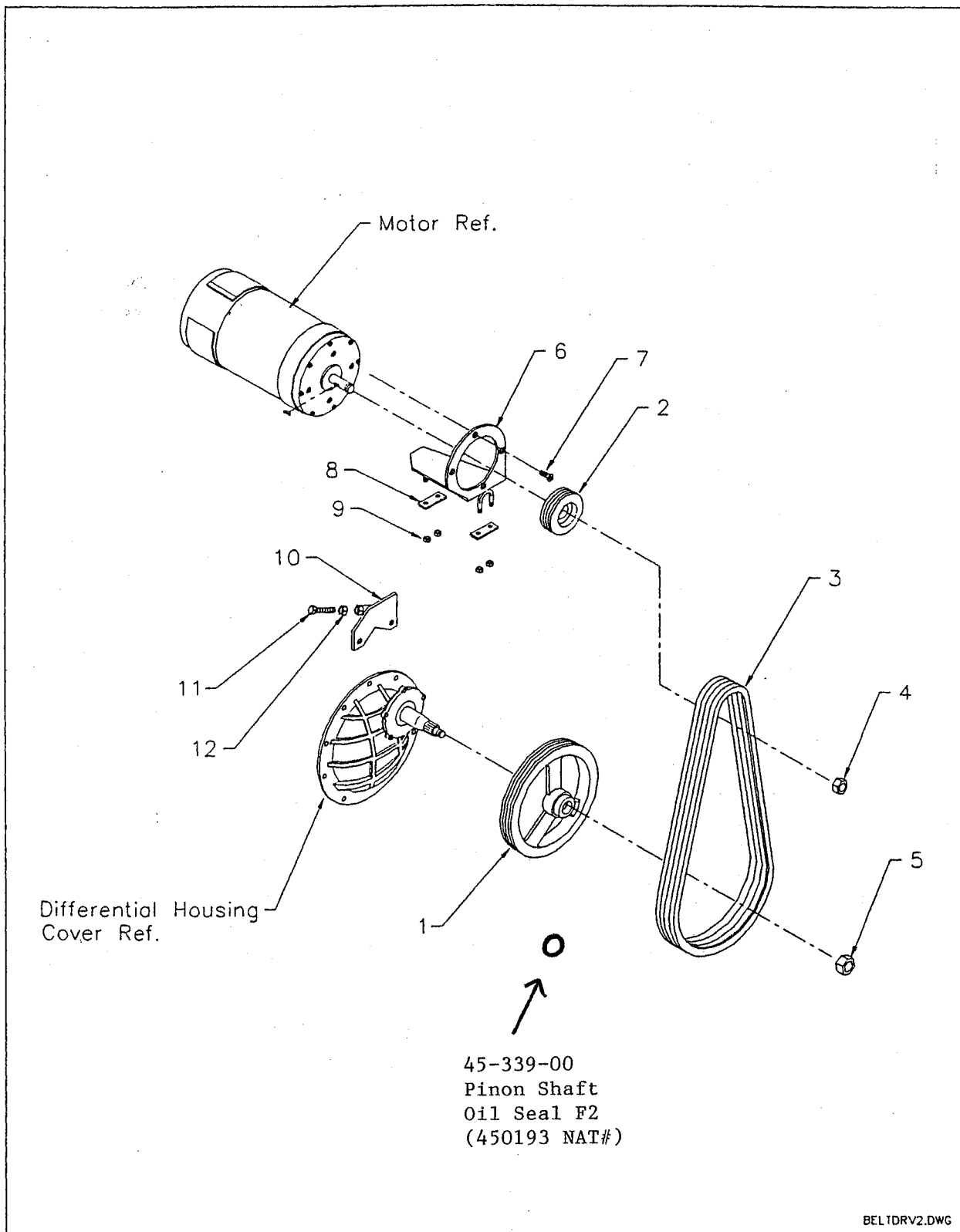

BELT DRIVE			
Item No.	Part No.	Description	Qty
1	30-121-10	Pulley, 4 Belt, 10.6" OD	1
2	30-158-00	Pulley, 4 Belt, 2.43" OD (used on 10.5 mph drive)	1
2a	30-159-00	Pulley, 4 Belt, 3.00" OD (used on 12.0 mph drive)	1
3	30-620-00	Belt, 3V x 400, R-Edge	4
4	88-239-82	Nut, Motor, 3/4NF Jam	1
5	97-250-00	Nut, Pinion, 3/4NF	1
6	00-380-96	Motor Mount	1
7	88-100-11	Bolt, 3/8NC x 1" Hex Hd	4
8	70-422-00	Strap, Motor Mount	2
9	88-109-87	Nut, Keps, 3/8NC	4
10	41-381-10	Motor Adjuster	1
11	96-316-00	Bolt, All Thread, 1/2NC x 3	1
12	88-149-80	Nut, 1/2NC	1

SECTION 4

POWER TRACTION DRIVE

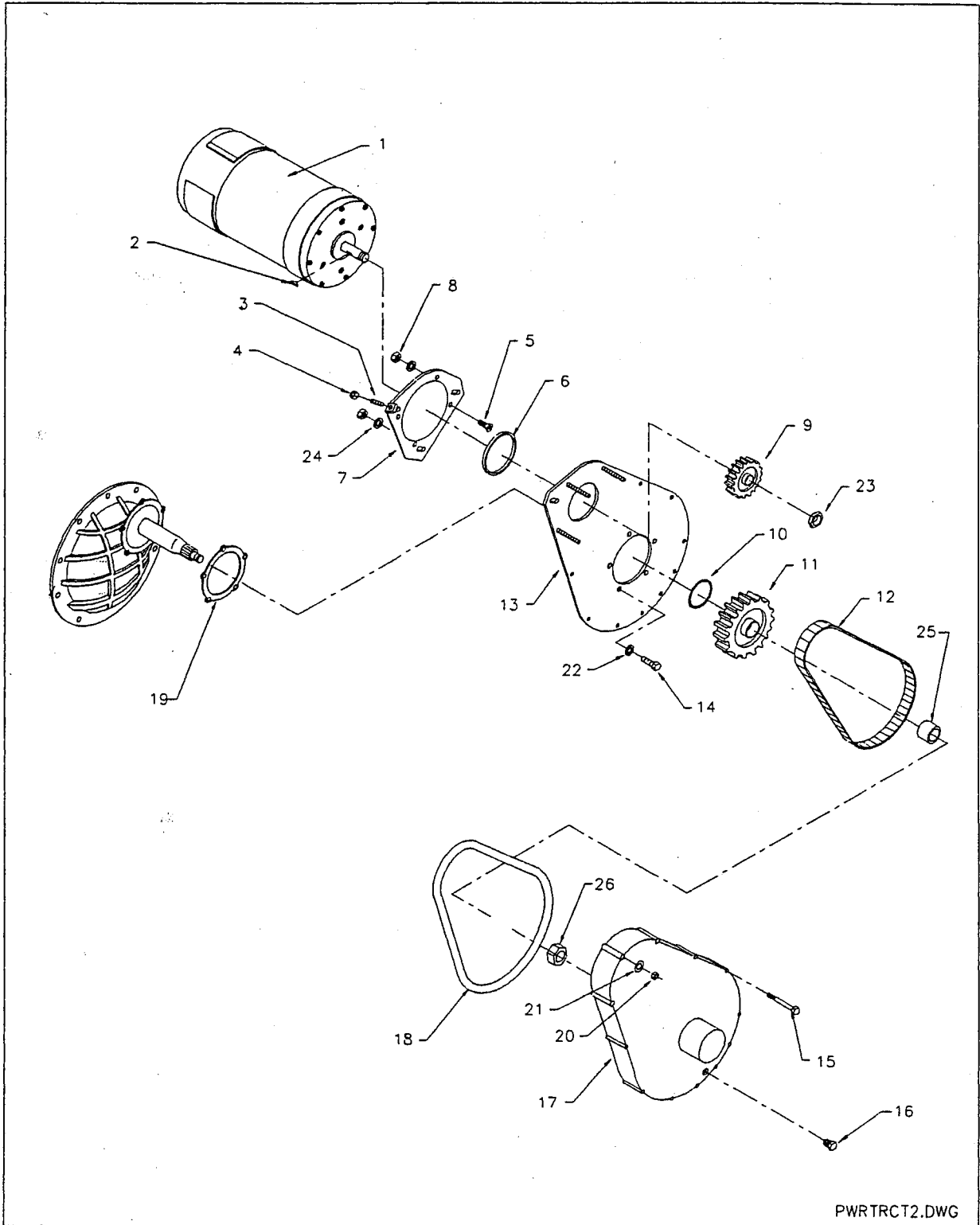

PWRTRCT2.DWG

POWER TRACTION DRIVE			
Item No.	Part No.	Description	Qty
1	70-049-00	Motor, DC, 4.5/6.0 hp	1
1a	70-054-00	Motor, DC, 6.7/10.0 hp	1
1b	70-054-20	Motor, DC, 6.7/10.0 hp	1
2	97-100-00	Woodruff Key	1
3	88-087-11	Chain Adjusting Screw	1
4	88-069-80	Nut, 5/16NC	1
5	88-103-09	Motor Mounting Screw	4
6	80-703-00	O-Ring	1
7	70-454-00	Motor Mounting Plate	1
8	88-109-80	Nut, 3/8NC	3
9	30-081-00	Motor Sprocket, 14 Tooth	1
10	16-415-00	Spacer	1
11	30-093-00	Pinion Sprocket, 81 Tooth	1
12	30-508-20	Drive Chain, SSG	1
13	44-352-53	Backing Plate	1
14	88-101-13	Bolt, 3/8NC x 1-1/4" Hex Hd	5
15	88-080-19	Bolt, 5/16NC x 2-3/4" Hex Hd	9
16	41-989-00	Drain and Fill Plugs	2
17	43-201-30	Chain Cover	1
18	45-002-00	Chain Case Gasket	1
19	45-021-00	Backing Plate Gasket	1
20	88-089-81	Locknut, 5/16NC	12
21	88-088-61	Washer, 5/16 SAE	3
22	88-108-63	Lockwasher, Internal Tooth	5
23	88-239-82	Motor Nut	1
24	88-108-62	Lockwasher, 3/8"	3
25	16-423-00	Spacer, Sprocket	1
26	97-250-00	Pinion Nut	1

SECTION 4

REAR DIFFERENTIAL

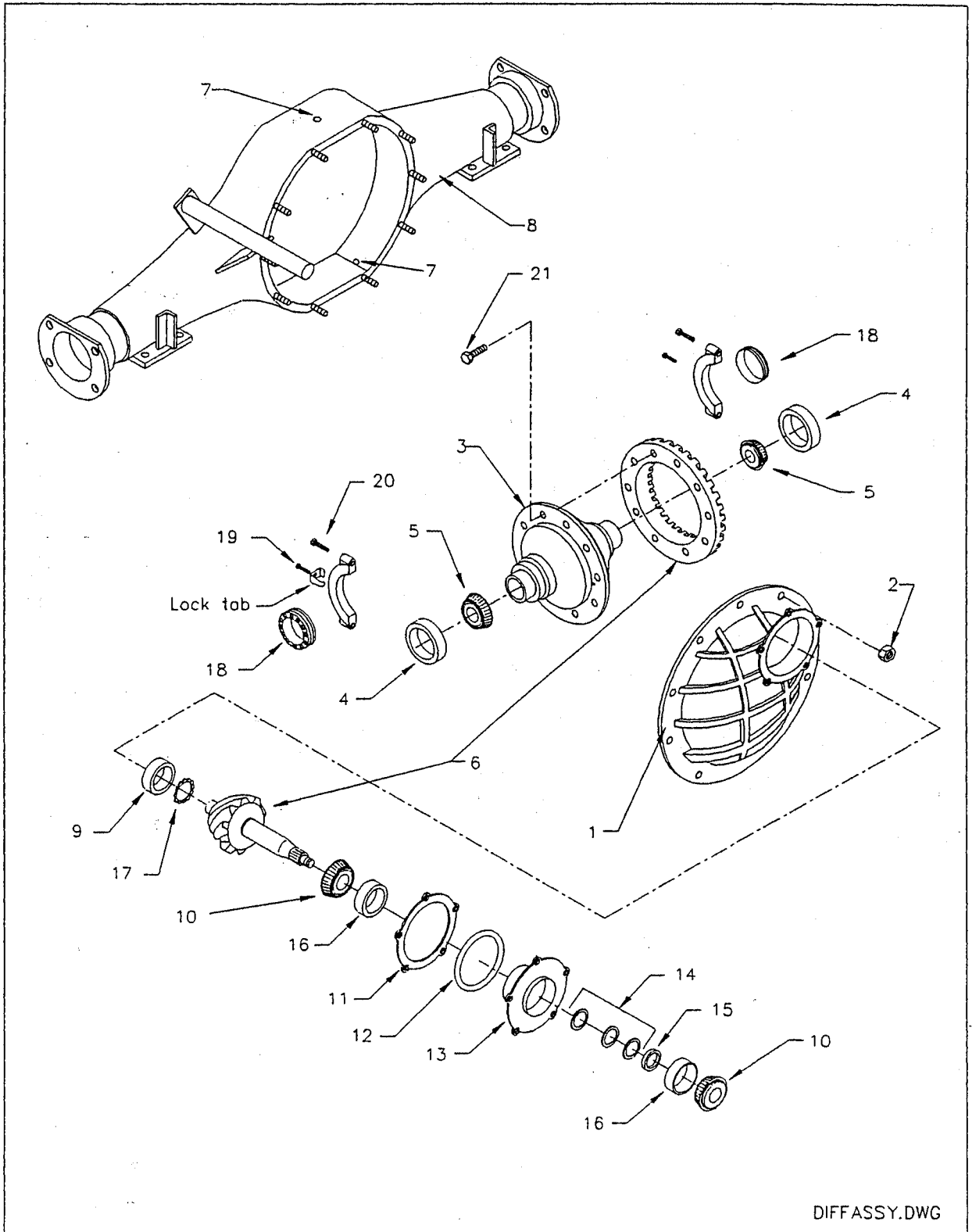

REAR DIFFERENTIAL			
Item No.	Part No.	Description	Qty
	44-340-10	3rd Member-Complete, 2.69/2.70/2.75 Ratio	1
	44-340-12	3rd Member-Complete, 3.00 Ratio	1
1	41-709-00	3rd Member Housing (small carrier bearing, 1.628"ID)	1
1a	41-710-00	3rd Member Housing (large carrier bearing, 1.784"ID)	1
2	88-119-80	Nut, 3/8NF	14
3	41-712-00	Carrier Assembly (small bearing)	1
3a	41-713-00	Carrier Assembly (large bearing)	1
4	80-127-00	Carrier Bearing Race (80-511-00 bearing)	2
4a	80-128-00	Carrier Bearing Race (80-512-00 bearing)	2
4b	80-129-00	Carrier Bearing Race (80-513-00 bearing)	2
5	80-511-00	Carrier Bearing, 1.628"ID (small)	2
5a	80-512-00	Carrier Bearing, 1.784"ID (large)	2
5b	80-513-00	Carrier Bearing, 1.7812"ID	2
6	31-235-00	Ring and Pinion Gear Set (2.75)	1
6a	31-234-00	Ring and Pinion Gear Set (3.00)	1
7	41-997-00	Oil Plugs	2
8	41-291-51	Differential Housing	1
9	80-555-00	Rear Pinion Bearing	1
10	80-554-00	Front Pinion Bearings	2
11	41-711-00	Pinion Housing Shim	1
12	80-702-00	O-Ring	1
13	44-340-90	Pinion Housing, w/Races	1
14	16-419-00	Shim, .002	as req'd
14a	16-420-00	Shim, .010	as req'd
14b	16-411-00	Shim, .005	as req'd
15	16-415-00	Spacer	1
16	80-125-00	Pinion Bearing Race	2
17	41-714-00	Pinion Bearing Retainer	1
18	41-707-00	Bearing Adjusting Nut (80-511-00 bearing)	2
18a	41-707-50	Bearing Adjusting Nut (80-512-00 bearing)	2
18b	41-708-50	Bearing Adjusting Nut (80-513-00 bearing)	2
19	88-080-04	Bolt, 5/16NC x 3/8" Hex Hd	2
20	88-140-16	Bolt, 1/2NC x 2" Hex Hd	2
21	96-243-00	Bolt, 7/16NC x 7/8" Hex Hd (locking)	10
22	96-316-00	Bolt, 1/2NC x 3" All Thread	4
23	88-148-62	Washer, 1/2"	4
24	88-149-80	Nut, 1/2NC	4

SECTION 4

REAR AXLE

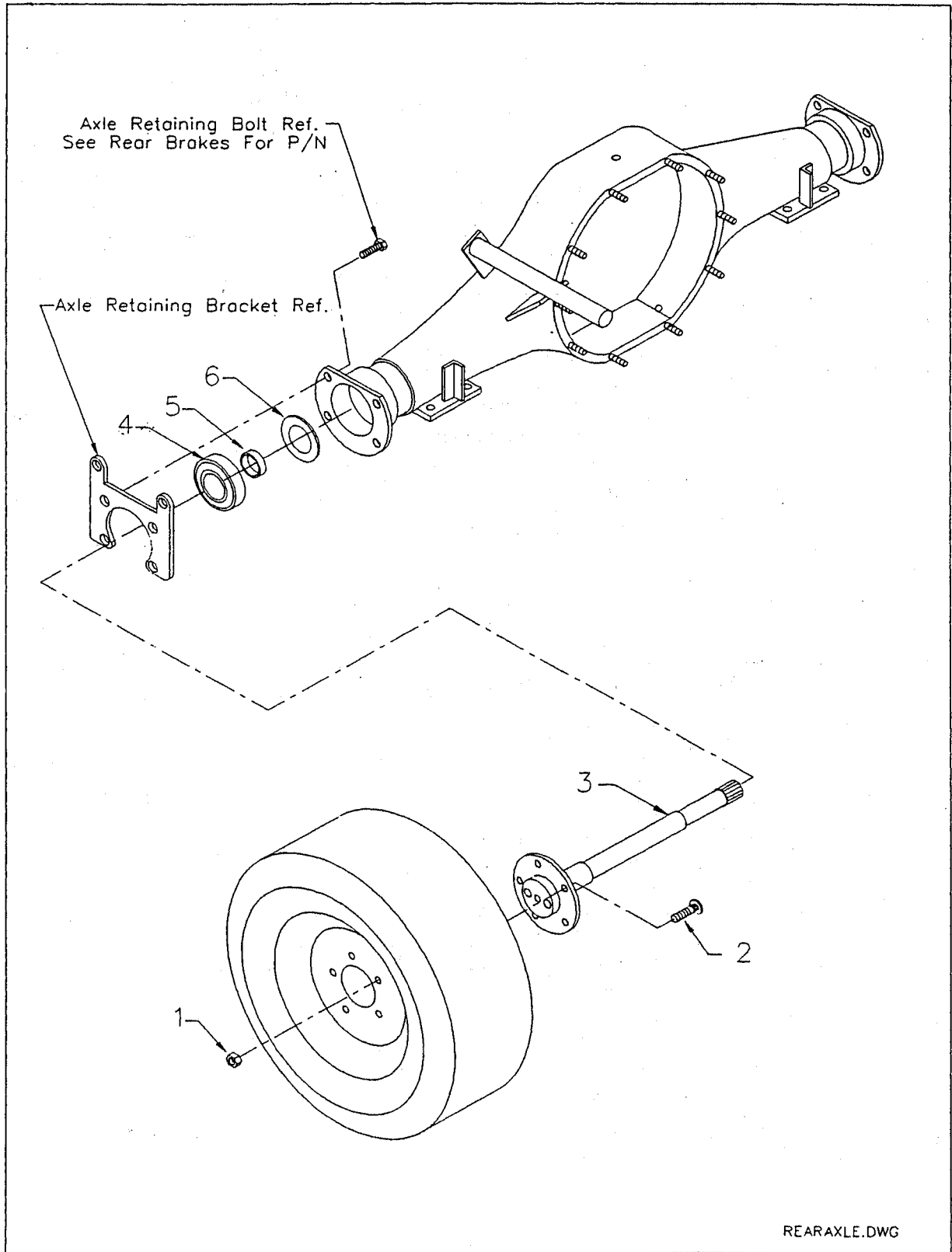

REAR AXLE			
Item No.	Part No.	Description	Qty
1	97-236-00	Wheel Lug Nut	10
2	96-329-10	Wheel Bolt	10
3	41-152-00	Axle, 17-1/8", Large Bearing (left side shown)	2
4	80-503-00	Axle Bearing, Ball Type	2
5	32-515-00	Bearing Retainer	2
6	45-301-00	Seal, Rear Axle	2

REAR SUSPENSION

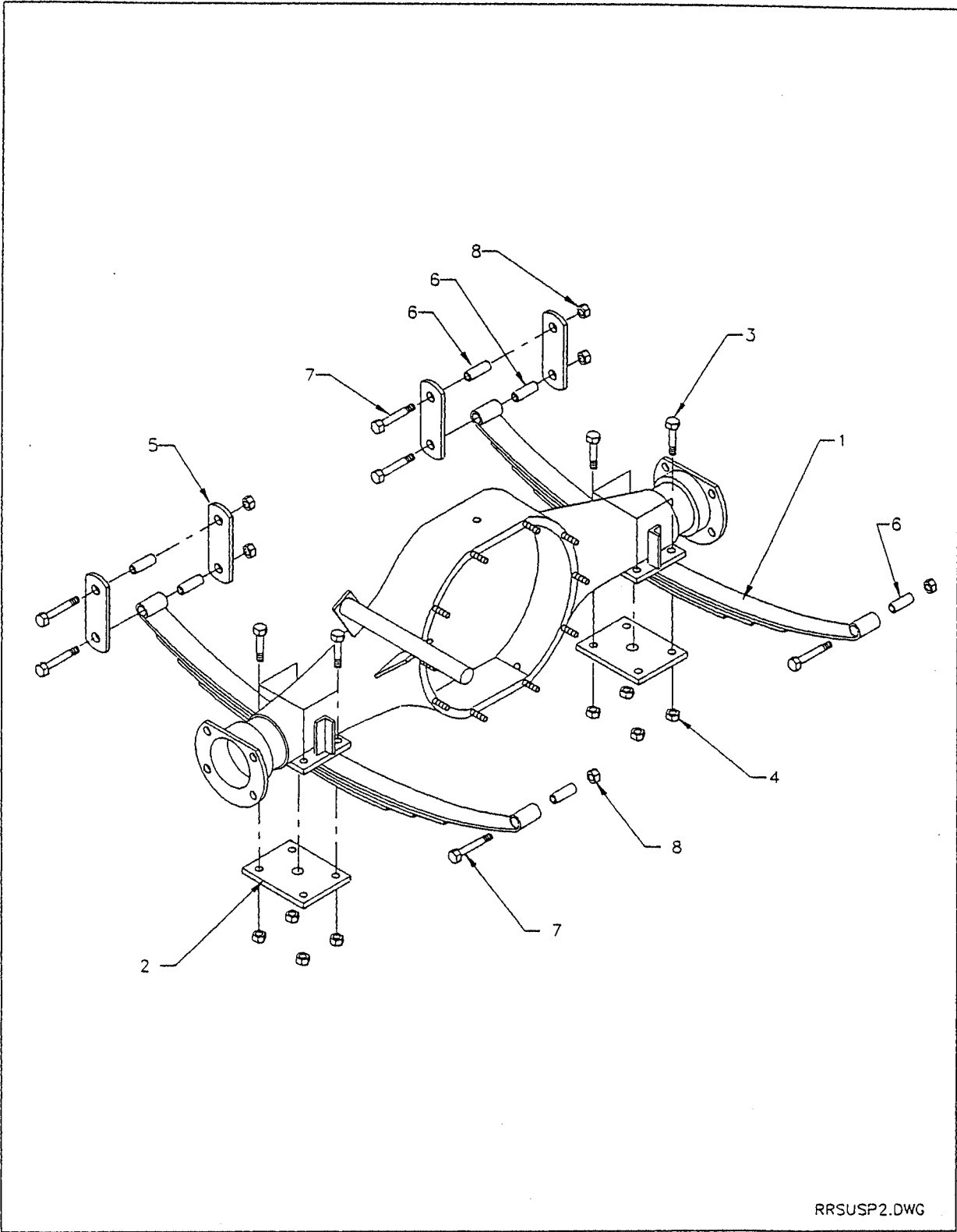

RRSUSP2.DWG

REAR SUSPENSION			
Item No.	Part No.	Description	Qty
1	85-513-10	Leaf Spring	2
2	16-861-00	Spring Pad	2
3	88-101-18	Bolt, 3/8NC x 2-1/2" Hex Hd, Grade 5	8
4	88-109-81	Locknut, 3/8NC	8
5	16-870-10	Spring Link	4
6	32-213-00	Bushing, 3/4" OD x 1.656" Long	6
7	96-248-00	Bolt, 9/16NF x 3"	6
8	88-169-82	Locknut, 9/16NF, Grade C	6

SECTION 4

TIRES

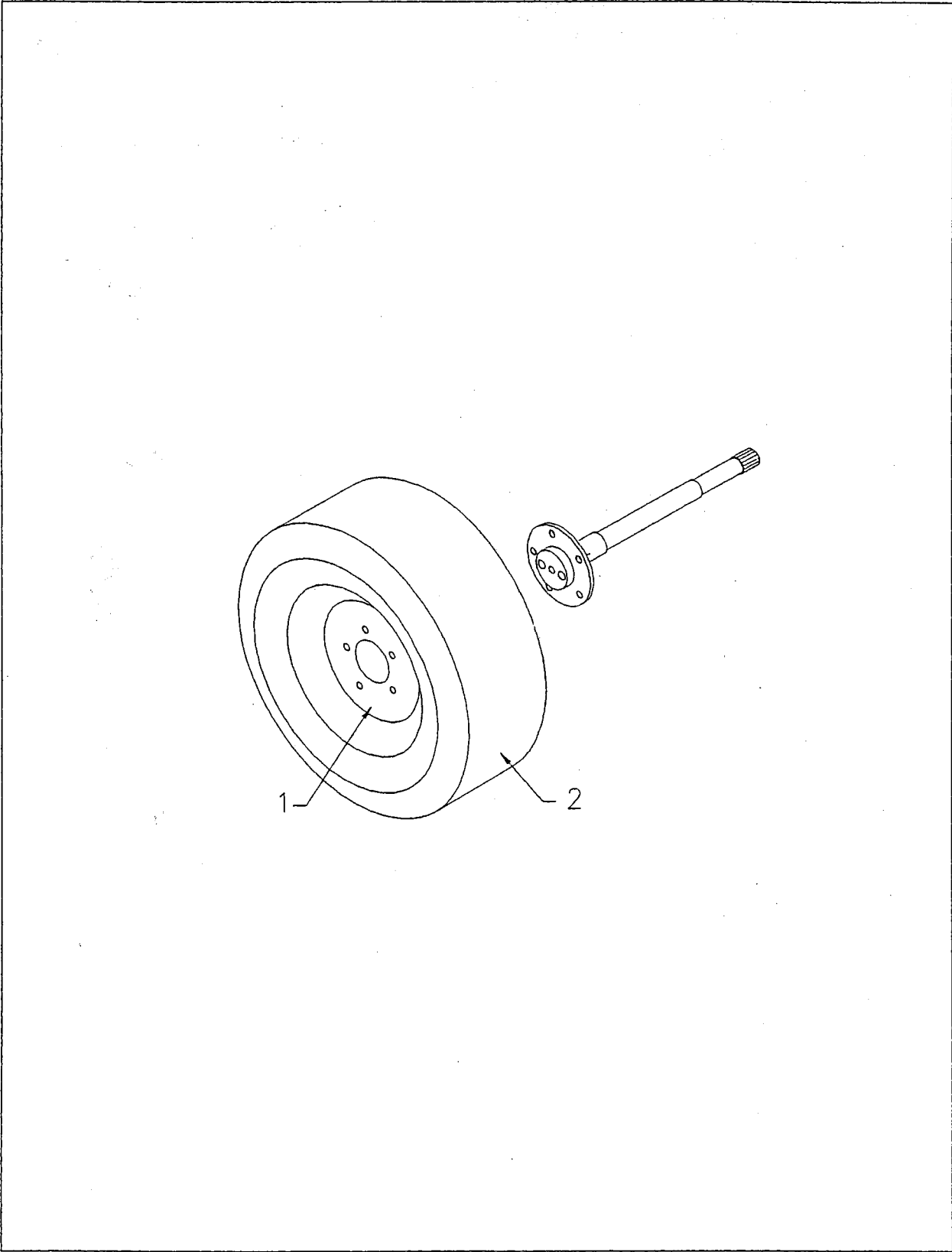

TIRES			
Item No.	Part No.	Description	Qty
Std	13-742-00	Tire & Wheel Assy, 5.70 x 8	4
1	12-012-00	Wheel, 3.75", 5 hole	4
2	10-081-00	Tire, 5.70 x 8, Load Range B, Tubeless	4
Opt.	13-742-11	Tire & Wheel Assy, 5.70 x 8, Split Rim	4
1	12-042-00	Wheel, 3.75", 5 hole, Split Rim (includes #1a,1b,1c,1d)	4
1a*	12-042-12	Wheel, Split Rim, Inner Half	4
1b*	12-042-13	Wheel, Split Rim, Outer Half	4
1c*	88-110-09	Bolt, 3/8NF x 3/4" Hex Hd, Grade 5	12
1d*	88-119-81	Locknut, 3/8NF	12
2	10-081-00	Tire, 5.70 x 8, LR B	4
*	11-040-00	Tube, 5.70 x 8	4
Opt.	13-742-40	Tire & Wheel Assy, 5.00 x 8, Split Rim, Man-Toter	4
1	12-042-00	Wheel, 3.75", 5 hole, Split Rim (includes #1a,1b,1c,1d)	4
1a*	12-042-12	Wheel, Split Rim, Inner Half	4
1b*	12-042-13	Wheel, Split Rim, Outer Half	4
1c*	88-110-09	Bolt, 3/8NF x 3/4" Hex Hd, Grade 5	12
1d*	88-119-81	Locknut, 3/8NF	12
2	10-086-00	Tire, 5.00 x 8, Man-Toter	4
Opt.	13-746-10	Tire & Wheel Assy, 8.50 x 8, Terra	4
1	12-020-00	Wheel, 7.00", 5 Hole	4
2	10-093-00	Tire, 8.50 x 8, Tubeless, Terra	4
*	92-000-00	Chrome Wheel Cover, 8" (optional)	4
*	92-001-00	Chrome Wheel Cover, 6" (optional)	4
*	92-002-00	Chrome Wheel Cover, 8" Split Rim (optional)	4

* Not shown in illustration.

SECTION 4

CONTROL PANEL

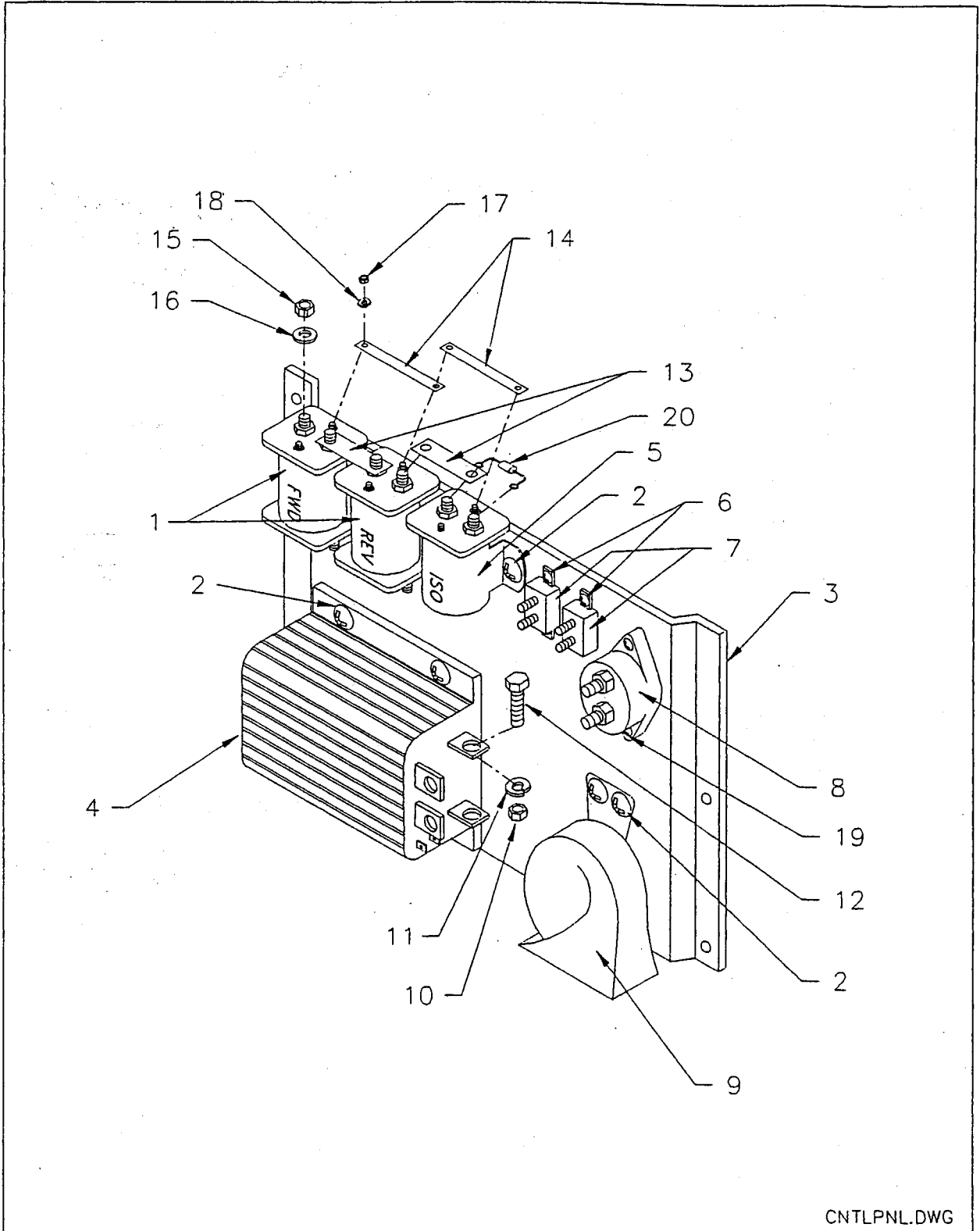

CONTROL PANEL			
Item No.	Part No.	Description	Qty
1	72-501-39	Forward or Reverse Solenoid	2
2	88-838-06	Sheet Metal Screw, #14 x 1/2"	10
3	01-534-80	Panel, Control Mounting	1
4	62-204-40	Speed Controller, 275 Plus 400	1
4a	62-205-00	Speed Controller, 400A, 24/36V (optional)	1
5	72-501-38	ISO Solenoid	1
6	88-818-06	Sheet Metal Screw, #8 x 1/2"	4
7	79-840-00	Circuit Breaker, 10 amp 12 & 36 volt	2
8	79-844-00	Circuit Breaker, 135 amp	1
8	79-844-20	Circuit Breaker, 200 amp (optional, used w/#4a)	1
9	73-004-20	Horn, 12 V	1
10	88-089-80	Nut, 5/16NC	4
11	88-088-62	Lockwasher, 5/16	4
12	88-080-11	Bolt, 5/16NC x 1" Hex Hd	4
13	61-838-41	Bus Bar, 5/8" x 1-1/2" Hole Centers	2
14	61-838-42	Bus Bar, 3/8" x 2-5/8" Hole Centers	2
15	88-099-91	Nut, 5/16NF Thin Pattern	10
16	88-088-63	Lockwasher, 5/16" Internal Tooth	10
17	88-049-80	Nut, #10-32	6
18	88-048-62	Lockwasher, #10	6
19	88-817-09	Sheet Metal Screw, #8 x 3/4"	2
20	78-302-50	Resistor, 250 ohm, 5 watt	1
Not Shown			
	75-148-25	Harness, Control Panel	1
	75-149-78	Harness, Power, Control Panel	1
	75-148-78	Harness, Control, Vehicle	1

SECTION 4

CONTROL PANEL-EE

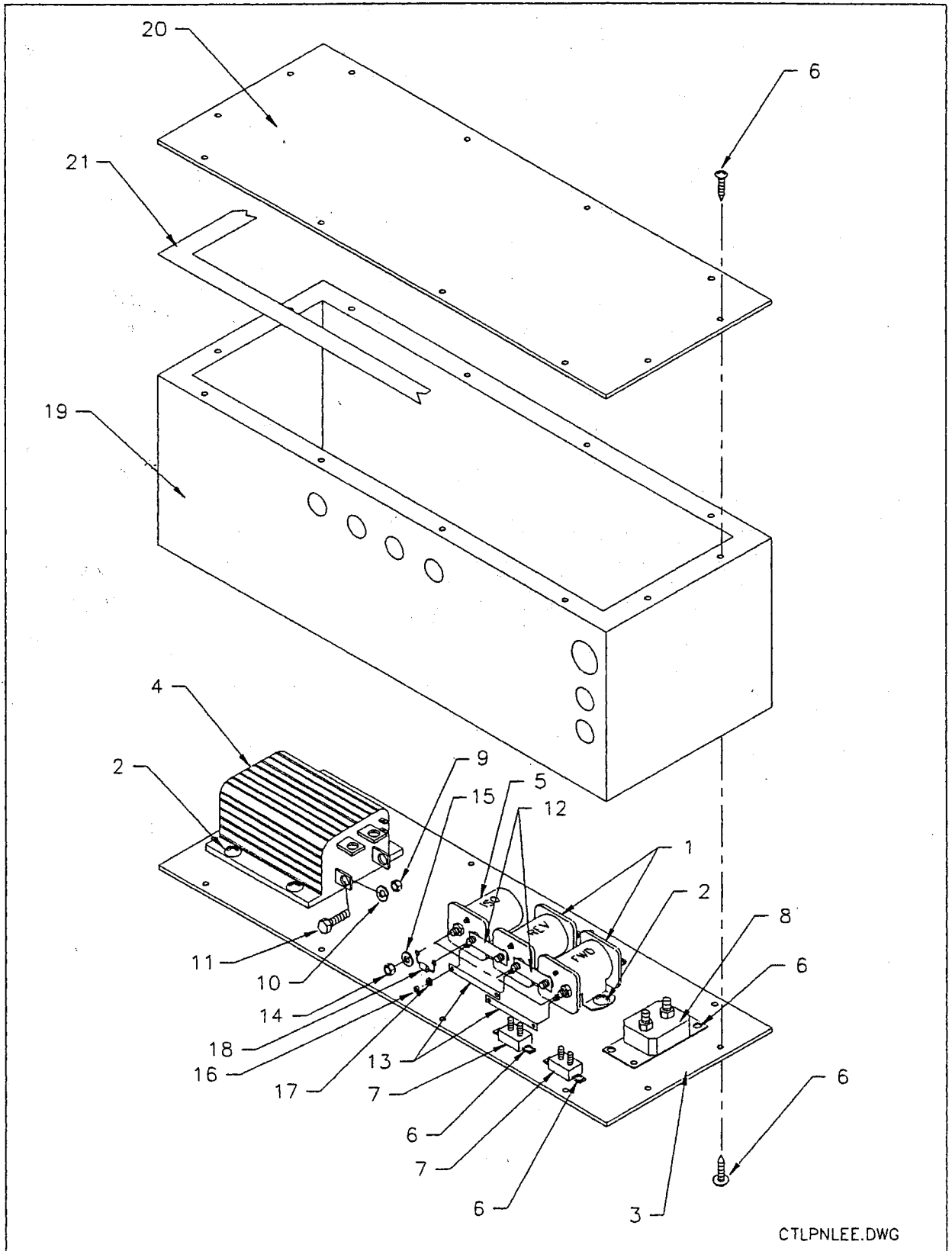

CONTROL PANEL-EE			
Item No.	Part No.	Description	Qty
1	72-501-39	Forward or Reverse Solenoid	2
2	88-838-06	Sheet Metal Screw, #14 x 1/2"	8
3	04-210-20	Panel, Control Box Floor	1
4	62-205-00	Speed Controller, 400 amp	1
5	72-501-38	ISO Solenoid	1
6	88-818-06	Sheet Metal Screw, #8 x 1/2"	30
7	79-840-00	Circuit Breaker, 10 amp	2
8	79-844-20	Circuit Breaker, 200 amp	1
9	88-089-80	Nut, 5/16NC	4
10	88-088-62	Lockwasher, 5/16	4
11	88-080-11	Bolt, 5/16NC x 1" Hex Hd	4
12	61-838-41	Bus Bar, 5/8" x 1-1/2" Hole Centers	2
13	61-838-42	Bus Bar, 3/8" x 2-5/8" Hole Centers	2
14	88-099-91	Nut, 5/16NF Thin Pattern	10
15	88-088-63	Lockwasher, 5/16" Internal Tooth	10
16	88-049-80	Nut, #10-32	6
17	88-048-62	Lockwasher, #10	6
18	78-302-50	Resistor, 250 ohm, 5 watt	1
19	00-210-02	Control Box	1
20	04-210-23	Lid, Control Box	1
21	98-451-20	Foam Tape, 1/8" x 1/2" Wide	8ft
Not Shown			
	75-146-71	Harness, Control Box	1
	75-149-60	Harness, Power	1
	75-146-70	Harness, Control, Vehicle	1

SECTION 4

ACCELERATOR MODULE

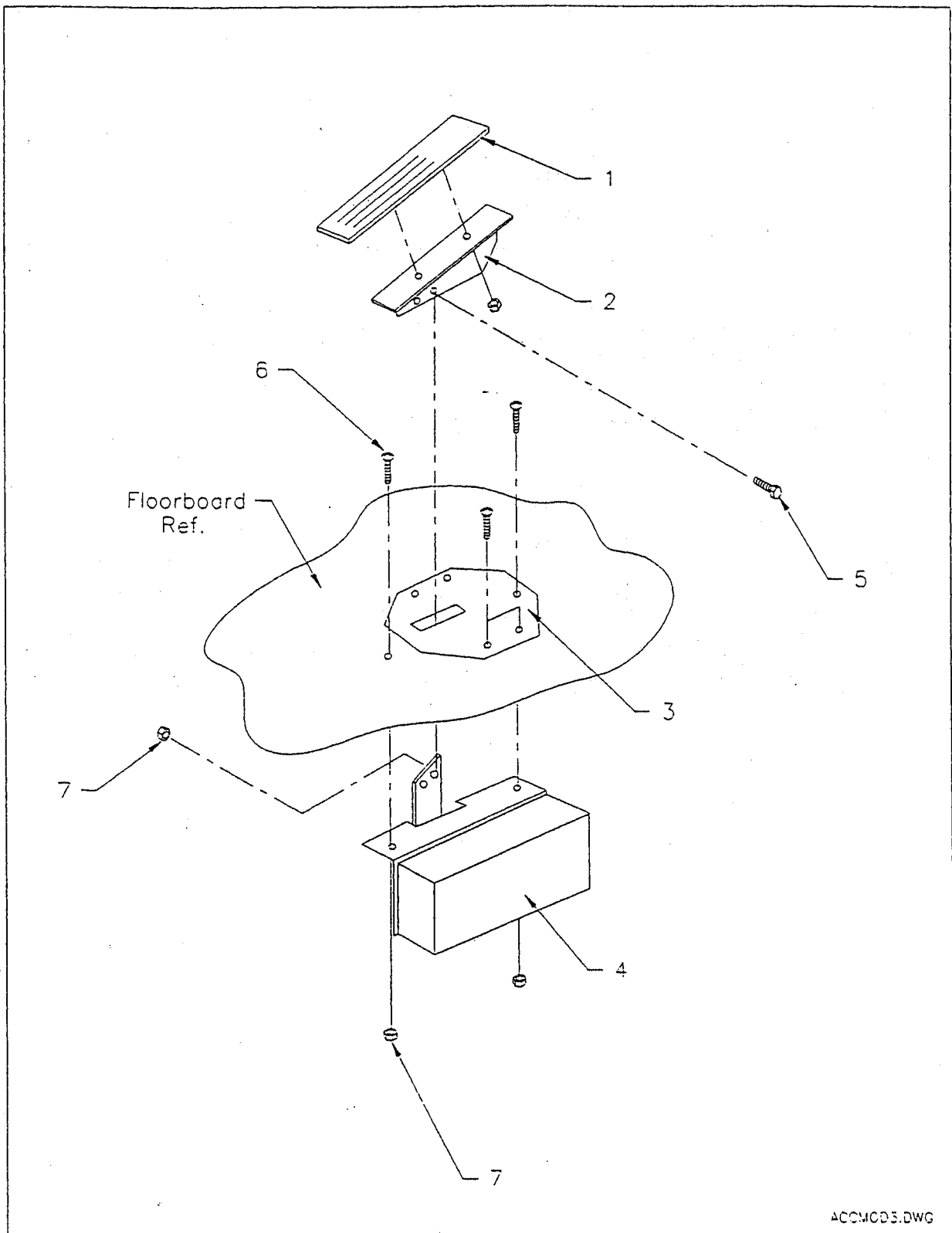

ACCMOD5.DWG

ACCELERATOR MODULE			
Item No.	Part No.	Description	Qty
1	98-254-00	Accelerator Pedal, Aluminum	1
2	98-254-25	Mount, Accelerator Pedal	1
3	03-210-96	Mounting Plate, Accelerator	1
4	62-033-00	Accelerator Module	1
5	88-060-09	Bolt, 1/4NC x 3/4" Hex Hd.	2
6	88-065-08	Screw, 1/4NC x 5/8" Truss Hd.	6
7	88-069-81	Locknut, 1/4NC	8

SECTION 4

INSTRUMENTATION

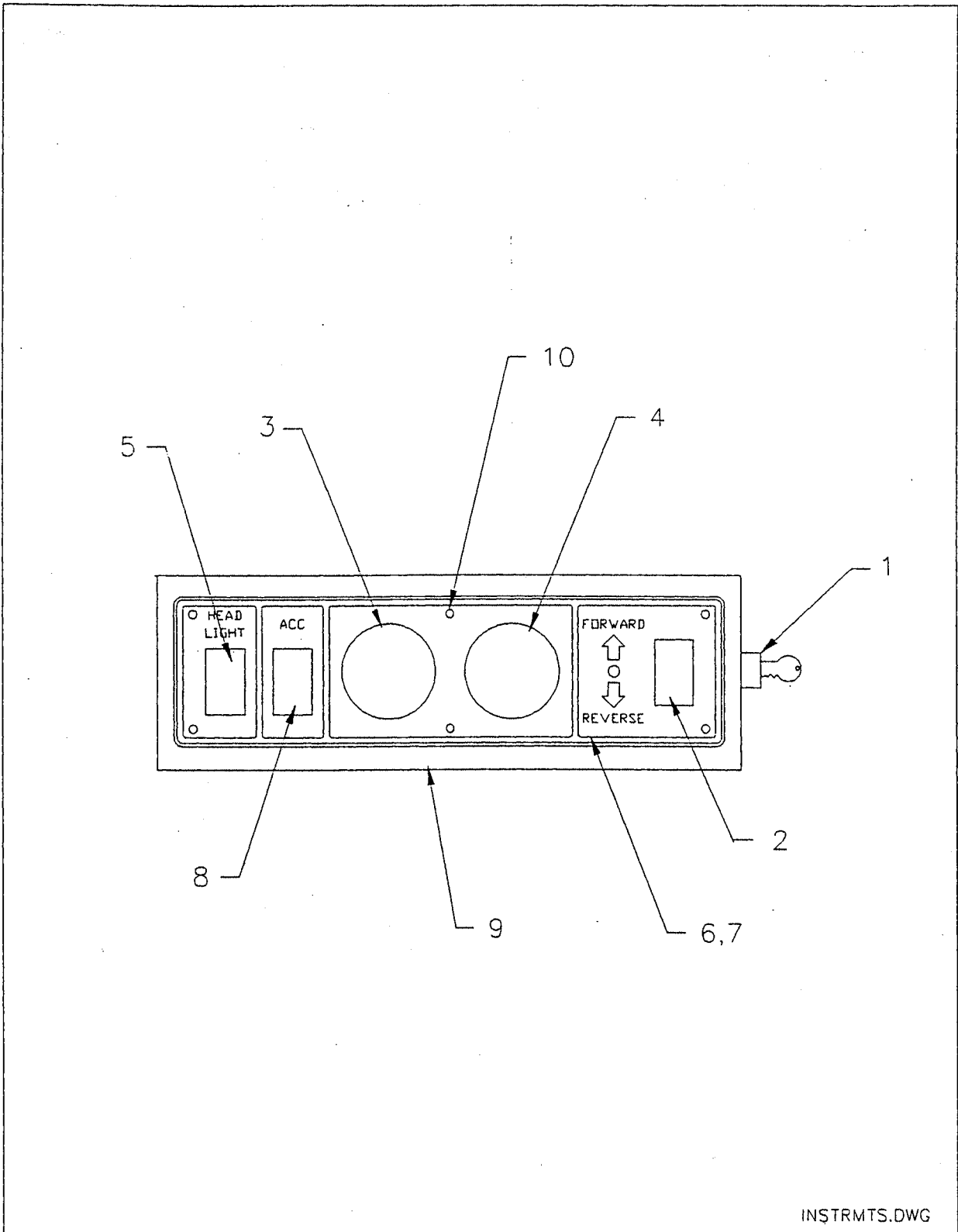

INSTRMTS.DWG

INSTRUMENTATION			
Item No.	Part No.	Description	Qty
1	71-120-00	Ignition Switch, Keyed Alike	1
1a	71-121-00	Ignition Switch, Keyed Unalike (optional)	1
2	71-039-00	Switch, Forward/Reverse	1
3	74-009-00	Battery Status Indicator	1
4	74-000-00	Hourmeter (optional)	1
5	71-039-10	Headlight Switch	1
6	94-304-10	Instrument Panel	1
7	88-817-07	Screw, #8 x 1/2" Tapping	6
8	71-039-20	Plug, Rocker Switch Hole	1
8a	71-039-10	Rocker Switch, On-Off (optional)	1
9	00-610-01	Instrument Console (painted black)	1
10	88-817-07	Screw, #8 x 1/2" Self Tapping	6

SECTION 4

BATTERIES

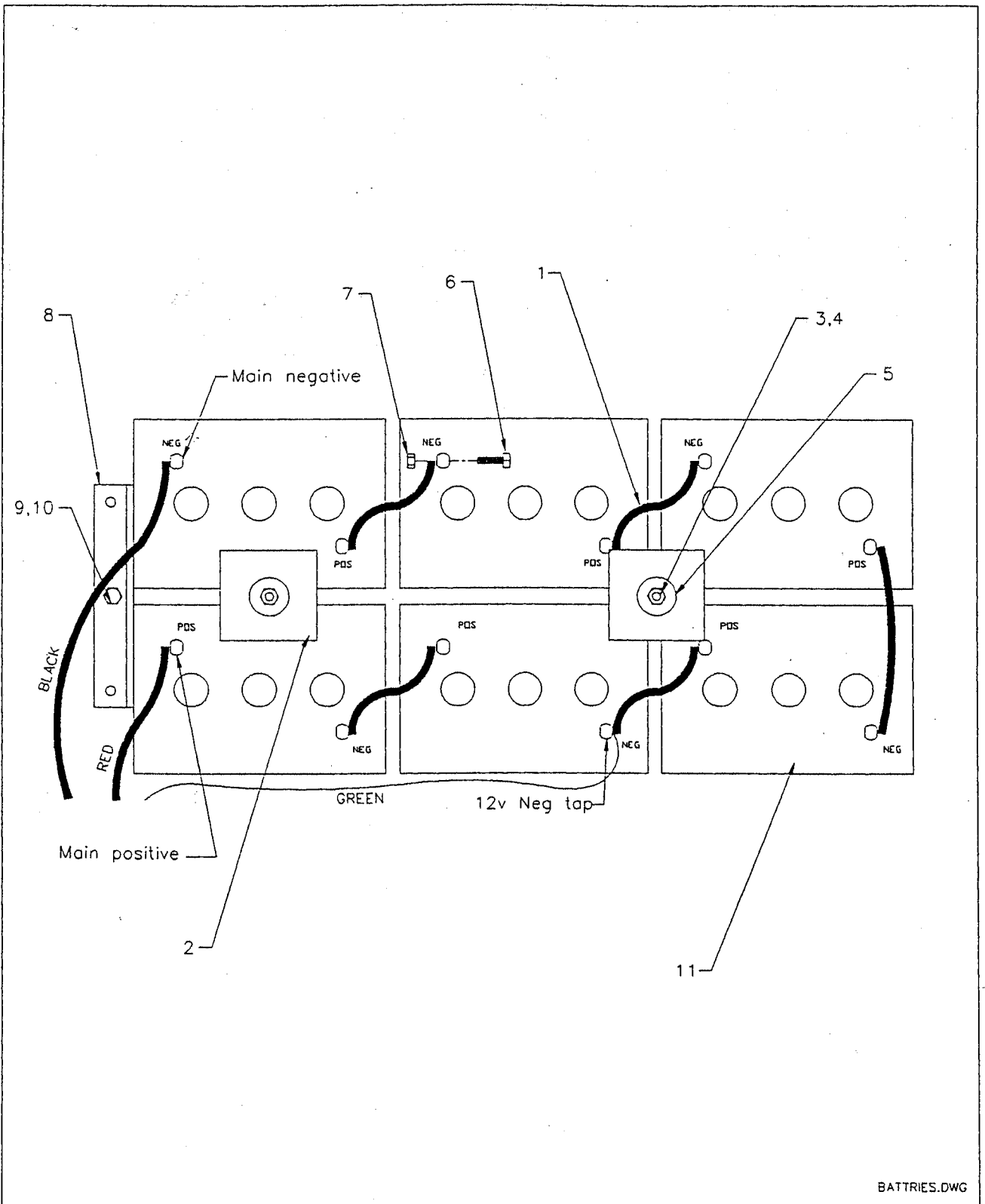

BATTERIES			
Item No.	Part No.	Description	Qty
1	75-231-00	Jumper, Battery, 10-1/4" long	5
2	50-250-00	Clamp, Battery Hold Down	2
3	50-243-10	Battery Rod	2
4	88-069-81	Locknut, 1/4NC	2
5	88-088-60	Washer, 5/16" Cut	2
6	88-081-12	Bolt, 5/16NC Square Hd, Tin-Lead	12
7	88-089-80	Nut, 5/16NC, Tin-Lead	12
8	01-534-43	Battery Box Angle	1
9	88-060-09	Bolt, 1/4NC x 3/4" Hex Hd	1
10	88-069-87	Nut, 1/4NC Keps	1
11	77-042-00	Battery, 6 Volt, 217 amp hour (standard)	6
11	77-044-00	Battery, 6 Volt, 230 amp hour (optional)	6
11	77-047-00	Battery, 6 Volt, 244 amp hour (optional)	6
11	77-042-80	Battery, 6 Volt, 217 amp hour (optional)	6
11	77-047-80	Battery, 6 Volt, 244 amp hour (optional)	6

SECTION 4

DECALS & MISCELLANEOUS STANDARD PARTS

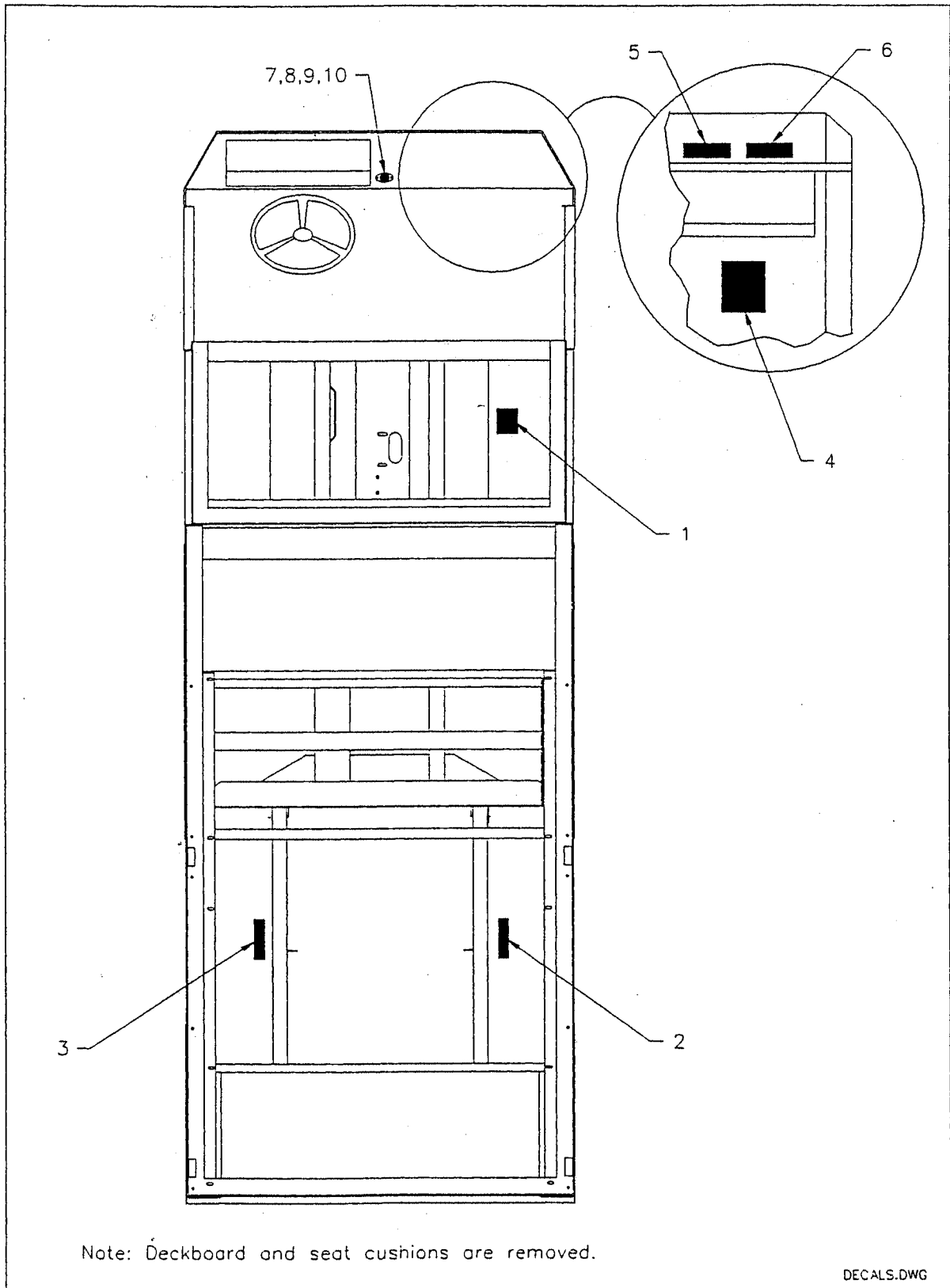

DECALS & MISCELLANEOUS STANDARD PARTS			
Item No.	Part No.	Description	Qty
1	94-373-10	Decal, Vehicle Data	1
2	94-319-00	Decal, Battery Disconnect	1
3	94-313-00	Decal, Battery Warning	1
4	94-313-20	Decal, Safety Warning	1
5	94-309-00	Decal, Brake Warning	1
6	94-384-01	Decal, Not Motor Vehicle	1
7	71-501-00	Horn Button	1
8	88-025-06	Screw, 8-32 x 1/2" Truss Hd	2
9	88-028-62	Lockwasher, #8	2
10	88-029-80	Nut, 8-32	2

SECTION 4

MISCELLANEOUS STANDARD PARTS-Cont'd

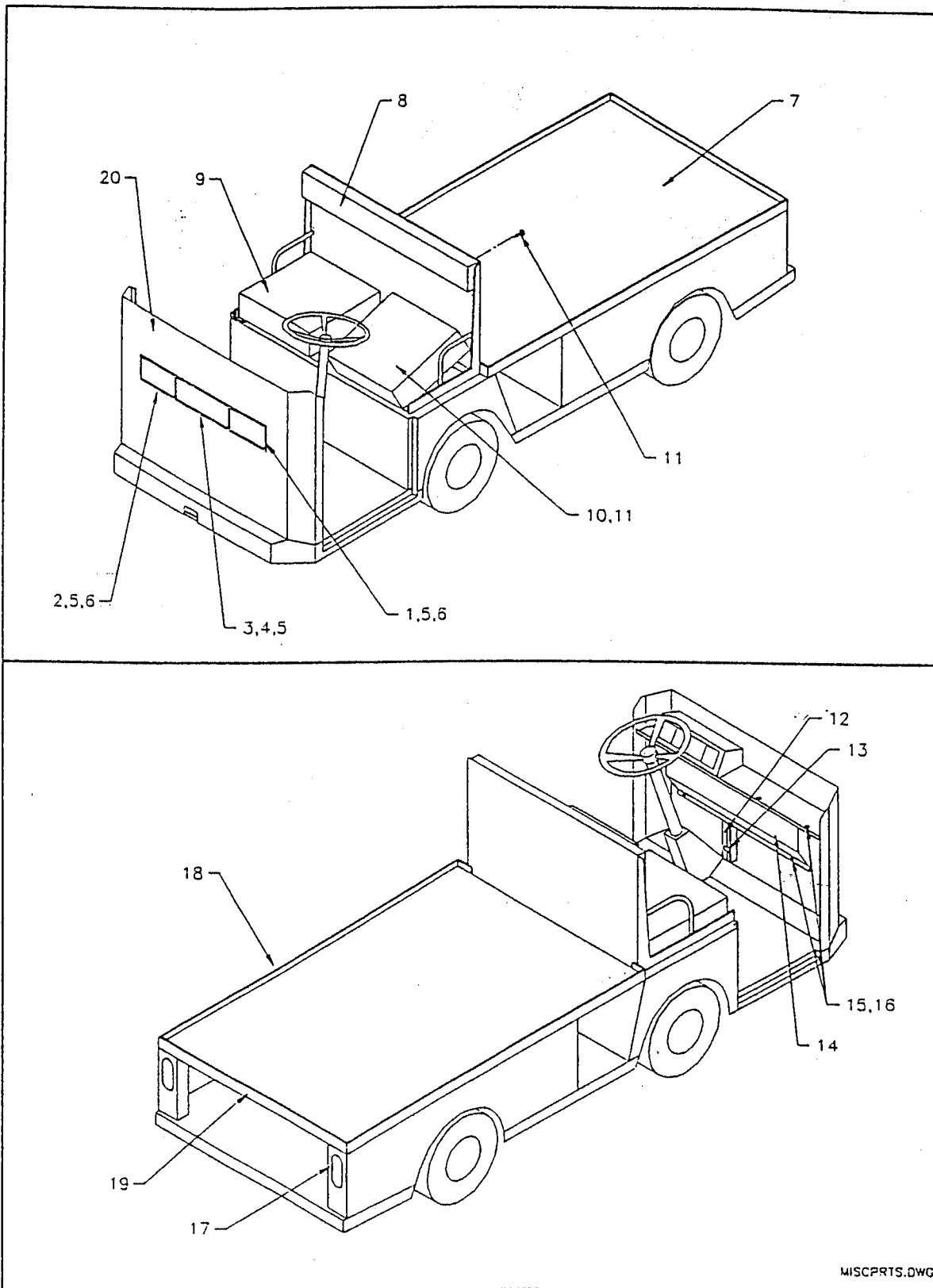

MISCPRTS.DWG

MISCELLANEOUS STANDARD PARTS-Cont'd			
Item No.	Part No.	Description	Qty
1	94-050-10	Headlight, Left	1
2	94-050-11	Headlight, Right	1
3	94-201-10	Taylor-Dunn® Name Plate	1
4	94-201-11	Fastener Strip, Plastic	2
5	88-817-07	Screw, #8 x 1/2" Self Tapping	14
6	94-050-04	Retainer, Headlight	4
7	90-444-00	Deckboard, 75-1/4" x 41"	1
8	90-179-00	Backrest	1
9	90-174-00	Seat Cushion, 17" x 19-1/2"	1
10	90-173-00	Seat Cushion, 17" x 18"	1
11	88-837-09	Screw, Sheet Metal, #14 x 3/4" Phillips Truss Hd	12
12	02-210-25	Angle, Wire Cover	1
13	91-513-00	S-Clip	2
14	00-210-22	Light Guard	1
15	88-065-06	Screw, 1/4NC x 1/2" Phillips Truss Hd	6
16	88-069-81	Locknut, 1/4NC	6
17	72-025-00	Light, Stop, Turn, & Tail	2
18	00-210-12	Side Rail (unpainted)	2
19	00-210-15	End Rail (unpainted)	1
20	00-610-00	Front Cowl (unpainted)	1

SECTION 4

OPTIONAL PARTS

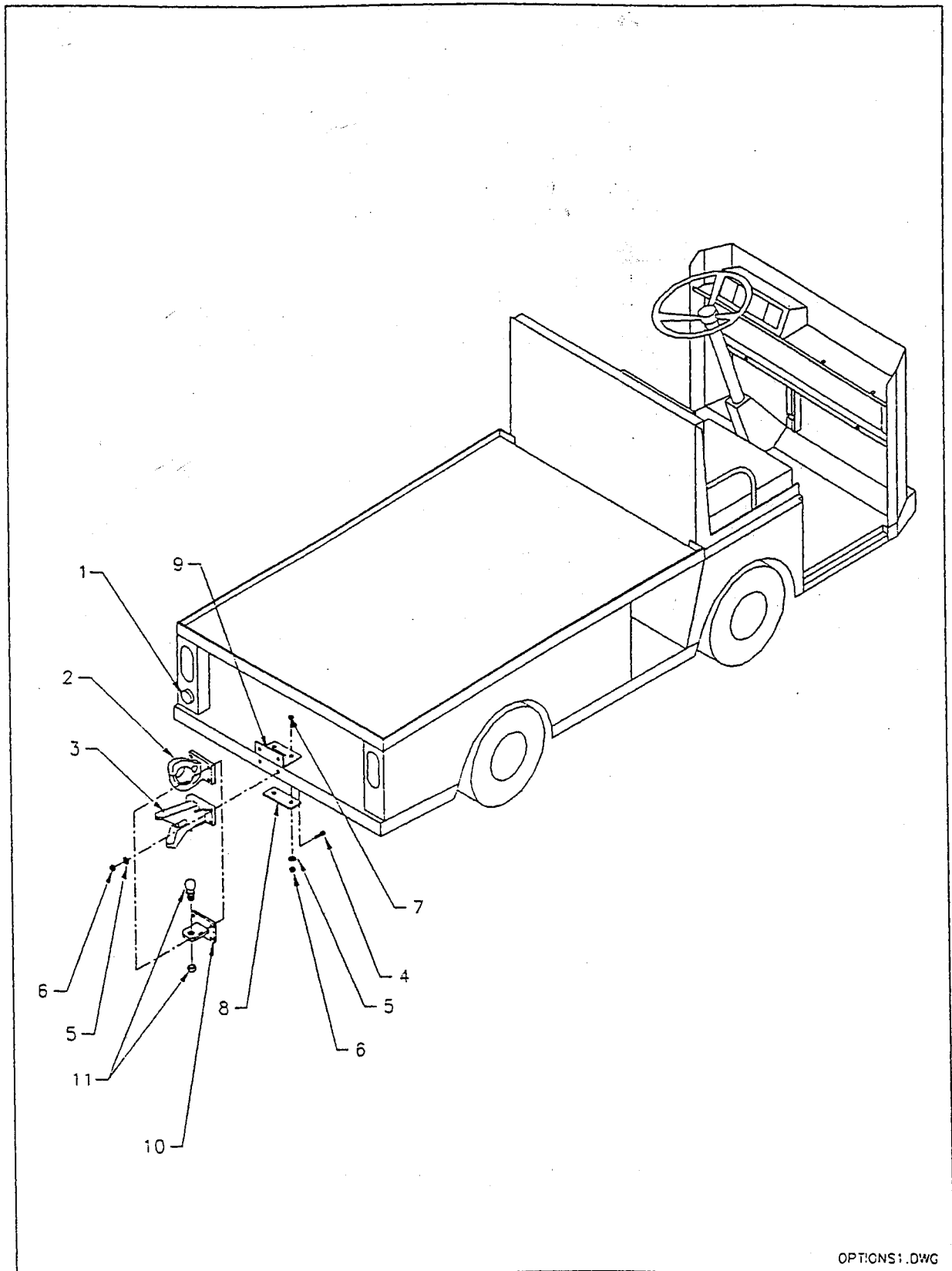

OPTIONS1.DWG

OPTIONAL PARTS			
Reverse Warning/Motion Beeper			
Item No.	Part No.	Description	Qty
1	73-005-05	Alarm, Pulsating	1
Hitches			
2	97-804-01	Hitch, Pintle Type	1
3	97-808-00	Hitch, Automatic Coupling	1
4	88-140-14	Bolt, 1/2NC x 1-1/2" Hex Hd	4
5	88-148-62	Lockwasher, 1/2"	6
6	88-149-80	Nut, 1/2NC	6
7	88-140-11	Bolt, 1/2NC x 1" Hex Hd	2
8	97-835-10	Plate, Hitch Mounting	1
9	97-835-00	Angle, Hitch Mounting	1
10	97-805-00	Bracket, Ball Hitch Mounting, 1-7/8"	1
10a	97-807-00	Bracket, Ball Hitch Mounting, 2"	1
11	97-811-00	Hitch, 1-7/8" Ball	1
11a	97-821-00	Hitch, 2" Ball	1

SECTION 4

OPTIONAL PARTS-Cont'd

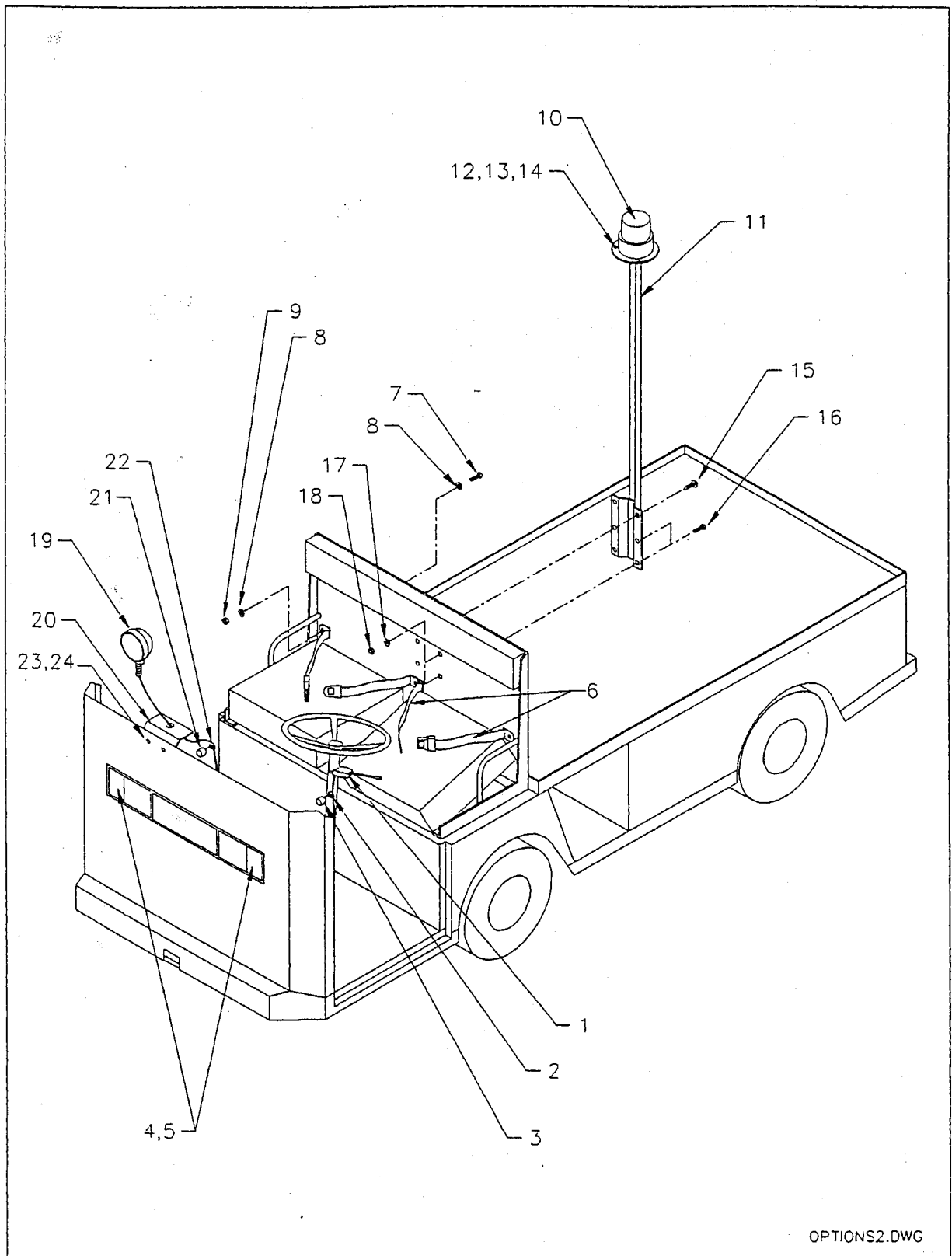

OPTIONS2.DWG

OPTIONAL PARTS-Cont'd			
Directional Signals			
Item No.	Part No.	Description	Qty
1	75-141-20 →	Turn Signal Switch 71-141-20	1
2	76-352-00	Flasher Receptacle	1
3	71-900-05	Flasher, 12V	1
4	72-082-10	Turn Signal Bulb, 12V	2
5	72-082-20	Socket, Turn Signal	2
Seat Belts			
6	90-199-10	Seat Belt, Black	1
7	88-151-13	Bolt, 1/2NC x 1-1/4" Hex Hd, Grade 5	3
8	88-148-61	Washer, 1/2"	6
9	88-159-84	Locknut, 1/2NC	3
Pole Mounted Strobe Light			
10	72-023-20	Strobe Light, Amber	1
11	72-023-25	Pole Mount, Strobe Light	1
12	88-025-06	Screw, #8-32 x 1/2" Truss Hd	3
13	88-028-62	Lockwasher, #8	3
14	88-029-80	Nut, #8-32	3
15	88-817-09	Screw, Sheet Metal, #8 x 3/4" Phillips Hd	2
16	88-065-08	Screw, 1/4NC x 5/8" Phillips Truss Hd	4
17	88-068-62	Lockwasher, 1/4"	4
18	88-069-83	Acorn Nut, 1/4NC	4
*	71-100-00	Toggle Switch	1
*	75-106-10	Harness, Strobe On Pole	1
Cowl Mounted Emergency Light			
19	72-023-15	Light, Emergency, Red	1
20	72-411-10	Bracket, Light Mounting	1
21	71-900-05	Flasher, 12V	1
22	76-352-00	Flasher Receptacle	1
23	88-065-08	Screw, 1/4NC x 5/8" Phillips Truss Hd	2
24	88-069-87	Nut, 1/4NC Keps	2
*	71-100-00	Toggle Switch	1
*	75-105-10	Harness, Cowl Mounted Light or Siren	1

71-039-10 Rocker Switch

* Not shown in illustration.

SECTION 4

OPTIONAL PARTS-Cont'd

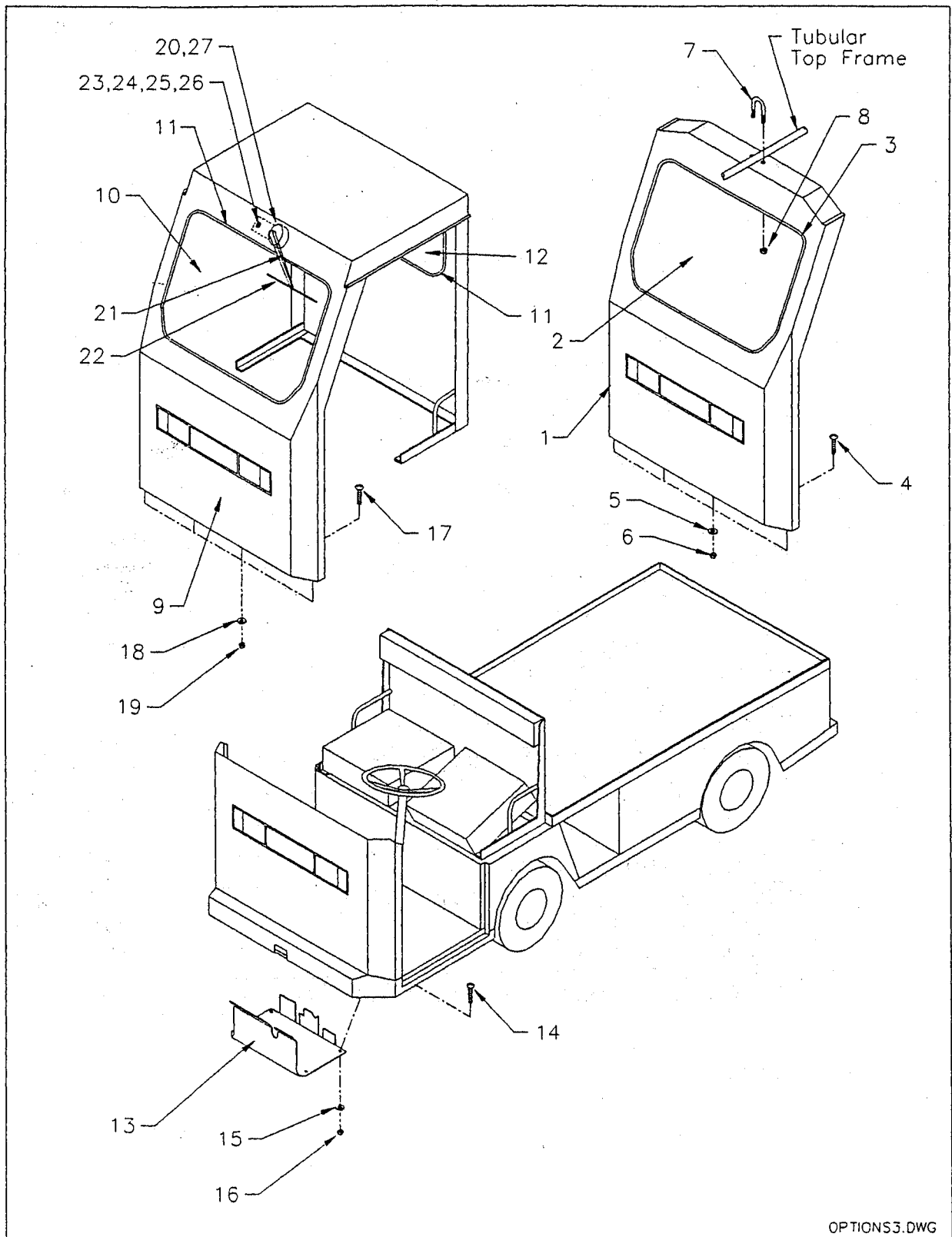

OPTIONS3.DWG

OPTIONAL PARTS-Cont'd			
Cowl w/Windshield			
Item No.	Part No.	Description	Qty
	91-013-64	Kit, Windshield, Orange (requires fiberglass or surrey top cover)	1
	91-013-65	Kit, Windshield, Specify Color (requires fiberglass or surrey top cover)	1
1	91-010-77	Cowl w/Windshield (unpainted)	1
2	90-852-30	Windshield	1
3	98-310-00	Window Channel, Rubber	12 ft
4	88-102-13	Bolt, 3/8NC x 1-1/4" Carriage	4
5	88-108-60	Washer, 3/8"	4
6	88-109-87	Nut, 3/8NC Keps	4
7	96-124-00	U-Bolt, 1/4NC x 1-3/4"	1
8	88-069-83	Acorn Nut, 1/4NC	2
Cab			
	91-012-62	Kit, Cab, Orange	1
	91-012-63	Kit, Cab, Specify Color	1
9	91-012-00	Cab (unpainted)	1
10	90-852-30	Windshield	1
11	98-310-00	Window Channel, Rubber	20 ft
12	90-850-10	Rear Window	1
13	05-210-87	Floor Pan	1
14	88-065-09	Screw, 1/4NC x 3/4" Phillips Truss Hd	4
15	88-068-61	Washer, 1/4" SAE	4
16	88-069-81	Locknut, 1/4NC	4
17	88-102-13	Bolt, 3/8NC x 1-1/4" Carriage	4
18	88-108-60	Washer, 3/8"	4
19	88-109-87	Nut, 3/8NC Keps	4
Windshield Wipers			
20	74-050-00	Windshield Wiper Motor	1
21	74-051-00	Arm, Windshield Wiper	1
22	74-052-00	Blade, Windshield Wiper	1
23	88-065-11	Screw, 1/4NC x 1" Phillips Truss Hd	1
24	88-068-61	Washer, 1/4" SAE	2
25	88-069-83	Acorn Nut, 1/4NC	1
26	98-603-00	Grommet, 3/8" ID	1
27	98-618-00	Grommet, 3/4" ID	1
*	75-114-15	Harness, Wiper & Light	1
*	71-039-10	Switch, Wiper (located in accessory slot on instrument panel)	1

* Not shown in illustration.

SECTION 4

OPTIONAL PARTS-Cont'd

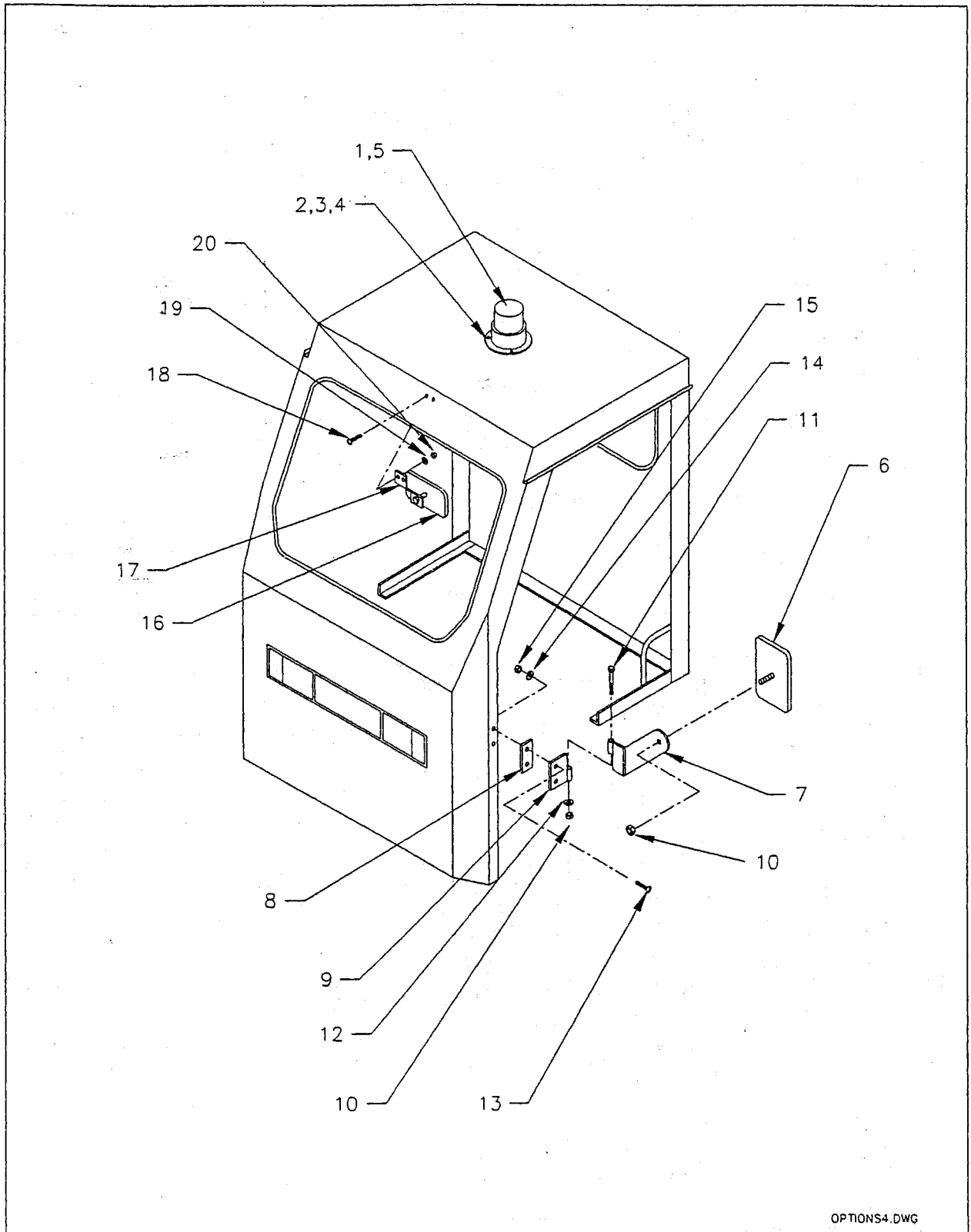

OPTIONAL PARTS-Cont'd			
Strobe Light On Cab			
Item No.	Part No.	Description	Qty
1	72-023-20	Strobe Light, Amber	1
2	88-025-06	Screw, #8-32 x 1/2" Truss Hd	3
3	88-028-62	Lockwasher, #8	3
4	88-029-80	Nut, #8-32	3
5	98-606-00	Grommet, 3/16" ID	1
*	75-114-15	Harness, Wiper & Light	1
*	71-100-00	Toggle Switch	1
Mirrors, Cowl, Cab, or Door Mounted			
6	92-201-00	Mirror, 4-1/2" x 8-1/2"	1 or 2
7	92-202-12	Mirror Mounting Bracket, Left	1
7a	92-202-13	Mirror Mounting Bracket, Right	1
8	92-202-15	Spacer, Mirror Bracket	1 or 2
9	91-814-16	Hinge, Female, Left	1
9a	91-814-17	Hinge, Female, Right	1
10	88-069-81	Locknut, 1/4NC	2
11	88-060-22	Bolt, 1/4NC x 3-1/2" Hex Hd	1
12	88-068-61	Washer, 1/4" SAE	1
13	88-065-09	Screw, 1/4NC x 3/4" Phillips Truss Hd	2 or 4
14	88-068-62	Lockwasher, 1/4"	2 or 4
15	88-069-83	Acorn Nut, 1/4NC	2 or 4
Mirror, Inside Cab			
16	92-206-00	Mirror, Inside	1
17	02-210-70	Bracket, Inside Mirror	1
18	88-065-09	Screw, 1/4NC x 3/4" Phillips Truss Hd	2
19	88-068-67	Lockwasher, Internal Tooth, 1/4"	2
20	88-069-80	Nut, 1/4NC	2
Mirror, Winks, Inside Cab			
*	91-810-00	Door Hinge	2
*	92-207-00	Mirror, 5 Panel	1

* Not shown in illustration.

SECTION 4

OPTIONAL PARTS-Cont'd

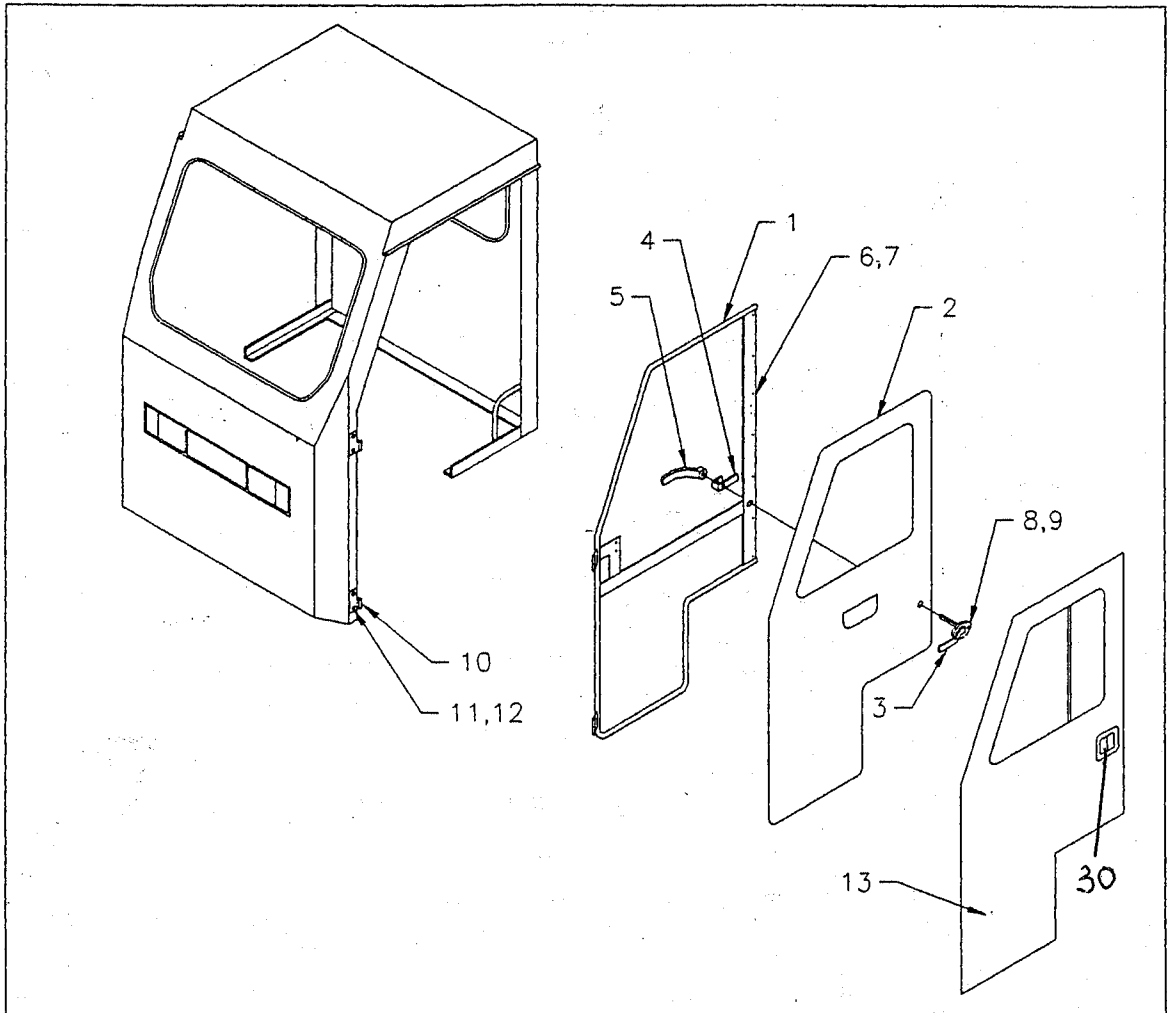

Note: Left Door Shown

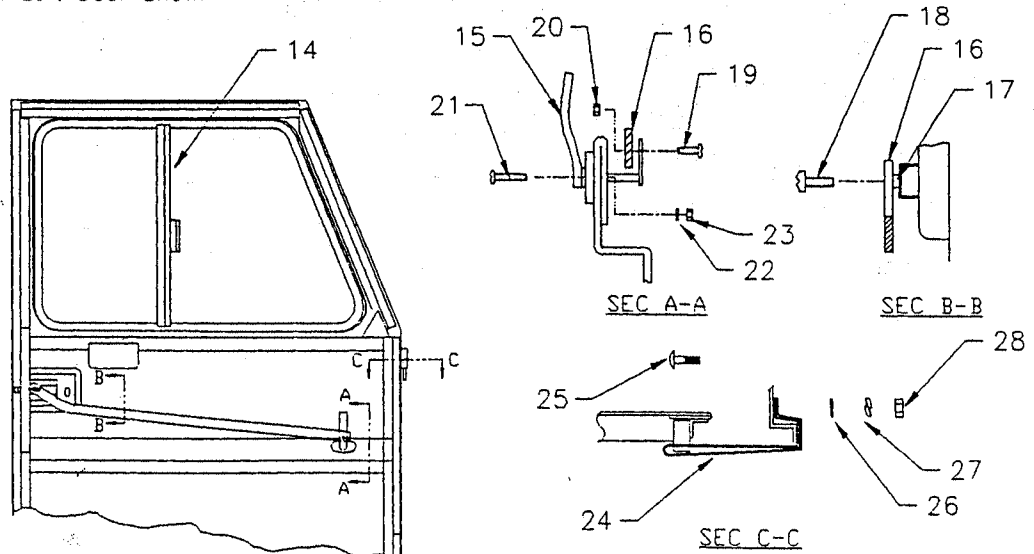

OPTIONS5.DWG

** Not shown in illustration OPTIONAL PARTS-Cont'd * Quantities are for one door only			
Cab Doors, Naugahyde			
Item No.	Part No.	Description	Qty
	90-924-60	Kit, Naugahyde Door, Left	1
	90-924-61	Kit, Naugahyde Door, Right	1
1	90-923-98	Door Frame, Left	1
**	90-923-99	Door Frame, Right	1
2	90-924-98	Side Curtain, Left	1
**	90-924-99	Side Curtain, Right	1
3	97-315-53	Handle Assembly, Outer	1*
4	97-315-51	Door Latch	1*
5	97-315-54	Handle, Inner	1*
6	97-303-03	Snap Fastener, Female	7*
7	88-727-06	Rivit, 5/32" x 1/2"	7*
8	88-025-08	Screw, #8-32 x 5/8" Truss Hd	2*
9	88-029-86	Locknut, #8-32	2*
10	91-814-10	Hinge, Female, Left	2
**	91-814-11	Hinge, Female, Right	2
11	88-082-09	Bolt, 5/16NC x 5/8" Carriage	4*
12	88-089-81	Locknut, 5/16NC	4*
Cab Doors, Metal			
13	91-011-66	Kit, Cab Door, Left, Specify Color (includes #10,11,12)	1
13	91-011-68	Kit, Cab Door, Left, Orange (includes #10,11,12)	1
**	91-011-67	Kit, Cab Door, Right, Specify Color (includes #10,11,12)	1
**	91-011-69	Kit, Cab Door, Right, Orange (includes #10,11,12)	1
14	90-853-10	Window, Left	1
**	90-853-11	Window, Right	1
15	97-315-58	Door Handle, Inner	1*
16	91-012-12	Connecting Bar	1*
17	16-510-00	Spacer	1*
18	88-065-06	Screw, 1/4NC x 1/2" Phillips Truss Hd	1*
19	88-045-08	Screw, #10-32 x 5/8" Truss Hd	1*
20	88-049-86	Locknut, #10-32	1*
21	88-045-11	Screw, #10-32 x 1" Truss Hd	2*
22	88-048-62	Lockwasher, #10	2*
23	88-049-80	Nut, #10-32	2*
24	91-012-45	Strap, Door Restraint	1*
25	88-082-11	Bolt, 5/16NC x 1" Carriage	1*
26	88-088-60	Washer, 5/16" Cut	1*
27	88-088-62	Lockwasher, 5/16"	1*
28	88-089-83	Acorn Nut, 5/16NC	1*
29	91-011-31	Door Weldment, Left (unpainted)	1
**	91-011-32	Door Weldment, Right (unpainted)	1
30	97-318-00	Latch, Door Handle, recessed	
	91-012-45	Strap	
	91-814-01	Hinge, Left	

SECTION 4

OPTIONAL PARTS-Cont'd

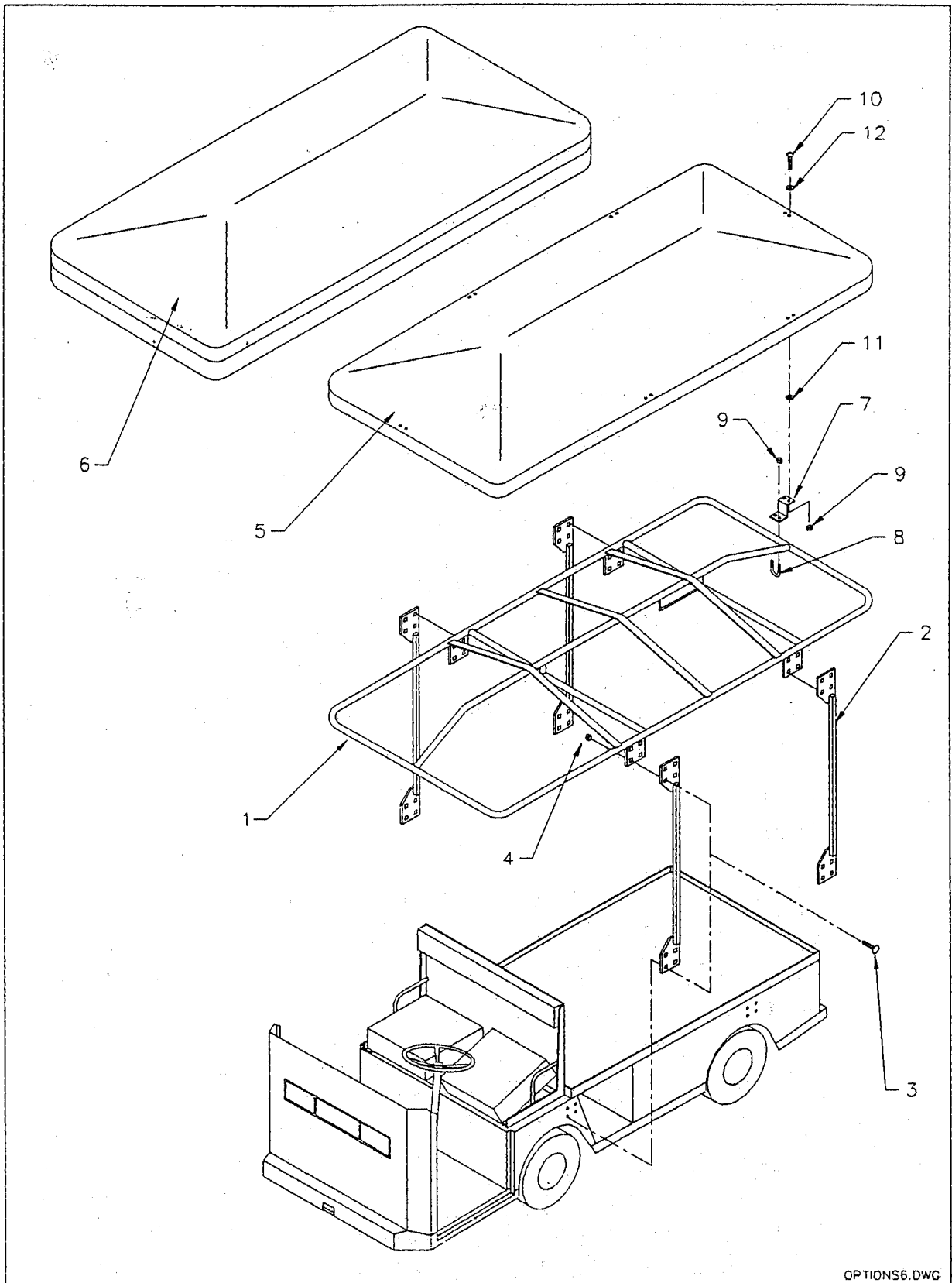

OPTIONS6.DWG

OPTIONAL PARTS-Cont'd			
Surrey Top Cover			
Item No.	Part No.	Description	Qty
	91-101-61	Kit, Surrey Top Cover	1
1	91-028-20	Tubular Top Frame	1
2	91-028-24	Post, Top Frame	4
3	88-102-11	Bolt, 3/8NC x 1" Carriage	32
4	88-109-81	Locknut, 3/8NC	32
6	91-101-00	Surrey Top, White	1
Fiberglass Top Cover			
	91-151-61	Kit, Fiberglass Top Cover	1
1	91-028-20	Tubular Top Frame	1
2	91-028-24	Post, Top Frame	4
3	88-102-11	Bolt, 3/8NC x 1" Carriage	32
4	88-109-81	Locknut, 3/8NC	32
5	91-151-00	Fiberglass Top, White	1
7	91-028-25	Z-Bracket	6
8	96-124-00	U-Bolt, 1/4NC x 1-3/4"	6
9	88-069-81	Locknut, 1/4NC	24
10	88-065-09	Screw, 1/4NC x 3/4" Phillips Truss Hd	12
11	97-176-00	Washer, Neoprene	12
12	88-068-60	Washer, 1/4 Cut	12
27	88-088-62	Lockwasher, 5/16"	1*
28	88-089-83	Acorn Nut, 5/16NC	1*

OPTIONAL PARTS-Cont'd

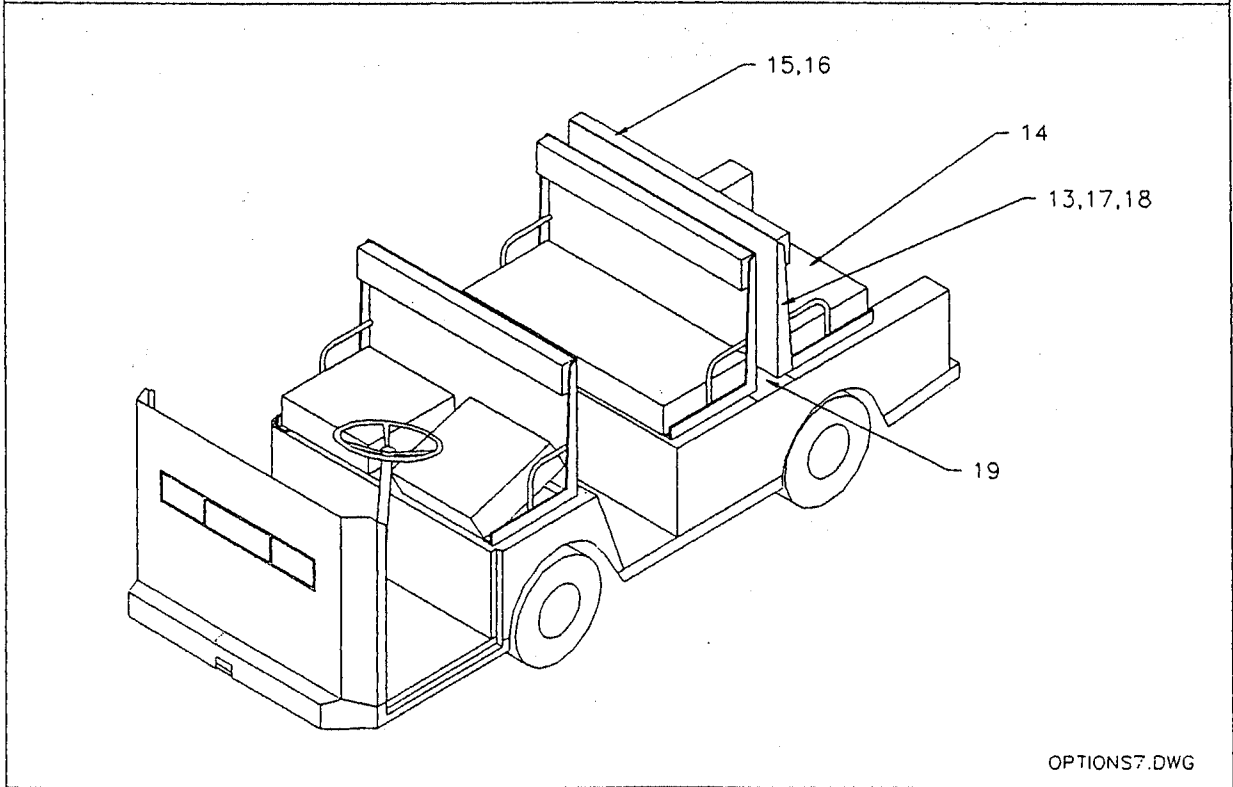
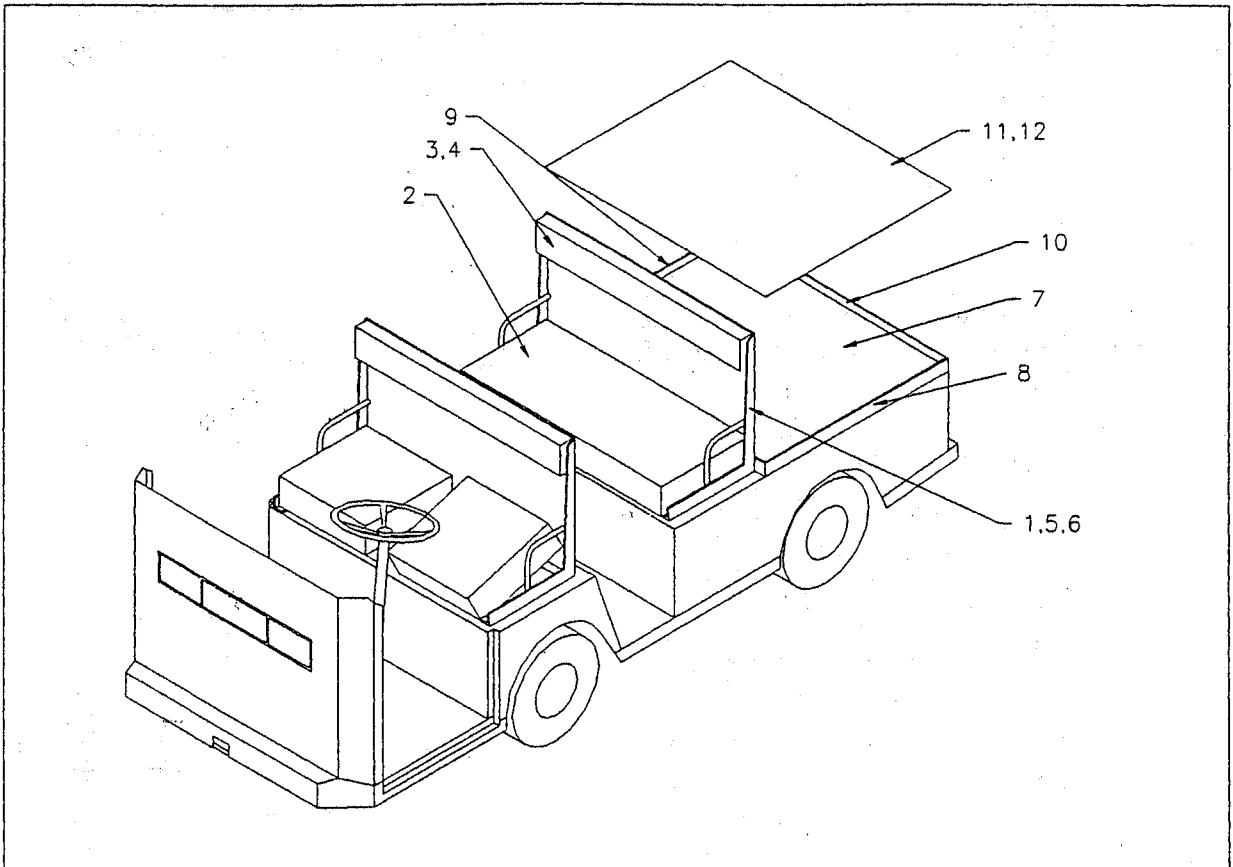

OPTIONS7.DWG

OPTIONAL PARTS-Cont'd			
Fixed 2nd Seat			
Item No.	Part No.	Description	Qty
	90-010-61	Kit, 2nd Seat, Orange	1
	90-010-64	Kit, 2nd Seat, Specify Color	1
1	00-210-01	Seat Bulkhead (unpainted)	1
2	90-175-00	Seat Cushion, Black	1
3	90-179-00	Seatback, Black	1
4	88-837-09	Screw, #14 x 3/4" Phillips Sheet Metal	8
5	88-065-09	Screw, 1/4NC x 3/4" Phillips Truss Hd	5
6	88-069-87	Nut, 1/4NC Keps	5
Deck, Fixed 2nd Seat			
7	90-444-20	Deckboard, 41" x 38-1/2" x 5/8" Thick, Black	1
8	00-210-19	Side Rail, Left, Fixed 2nd Seat (unpainted)	1
9	00-210-20	Side Rail, Right, Fixed 2nd Seat (unpainted)	1
10	00-210-15	Rear Deck Rail (unpainted)	1
***	00-210-23	Deck Support	1
***	88-065-08*	Screw, 1/4NC x 5/8" Phillips Truss Hd	11
***	88-065-09*	Screw, 1/4NC x 3/4" Phillips Truss Hd	8
***	88-068-61*	Washer, 1/4 SAE	16
***	88-069-87*	Nut, 1/4NC Keps	19
Deck Cover, Diamond Plate, Fixed 2nd Seat			
11	90-440-46	Deck Cover, Diamond Plate, Black	1
12	88-607-09	Rivet, 1/4" x 1/2" Starpin	8
Fixed 3rd Seat			
	90-010-62	Kit, 2nd & 3rd Seat, Orange	1
	90-010-65	Kit, 2nd & 3rd Seat, Specify Color	1
13	00-210-01	Seat Bulkhead (unpainted)	1**
14	90-175-00	Seat Cushion, Black	1**
15	90-179-00	Seatback, Black	1**
16	88-837-09	Screw, #14 x 3/4" Phillips Sheet Metal	8**
17	88-065-09	Screw, 1/4NC x 3/4" Phillips Truss Hd	5**
18	88-069-87	Nut, 1/4NC Keps	5**
19	02-210-32	Deck, 2nd & 3rd Seat	1**

* Hardware used to mount the side rails and rear rail to the frame, the rails to the seatback, and the deck support (located behind the seatback) to the frame.

** Quantities are for the 3rd seat only. The kit contains hardware for both 2nd & 3rd seats.

*** Not shown in illustration.

SECTION 4

OPTIONAL PARTS-Cont'd

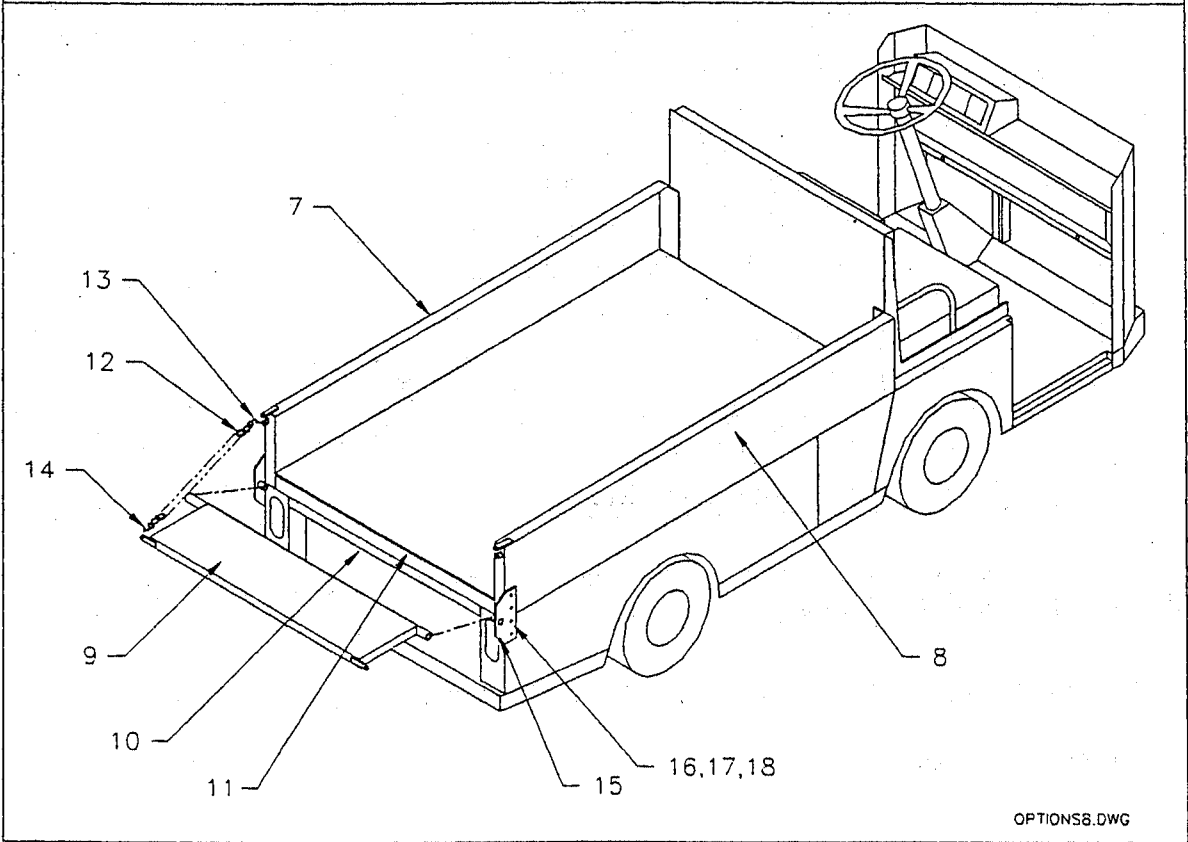
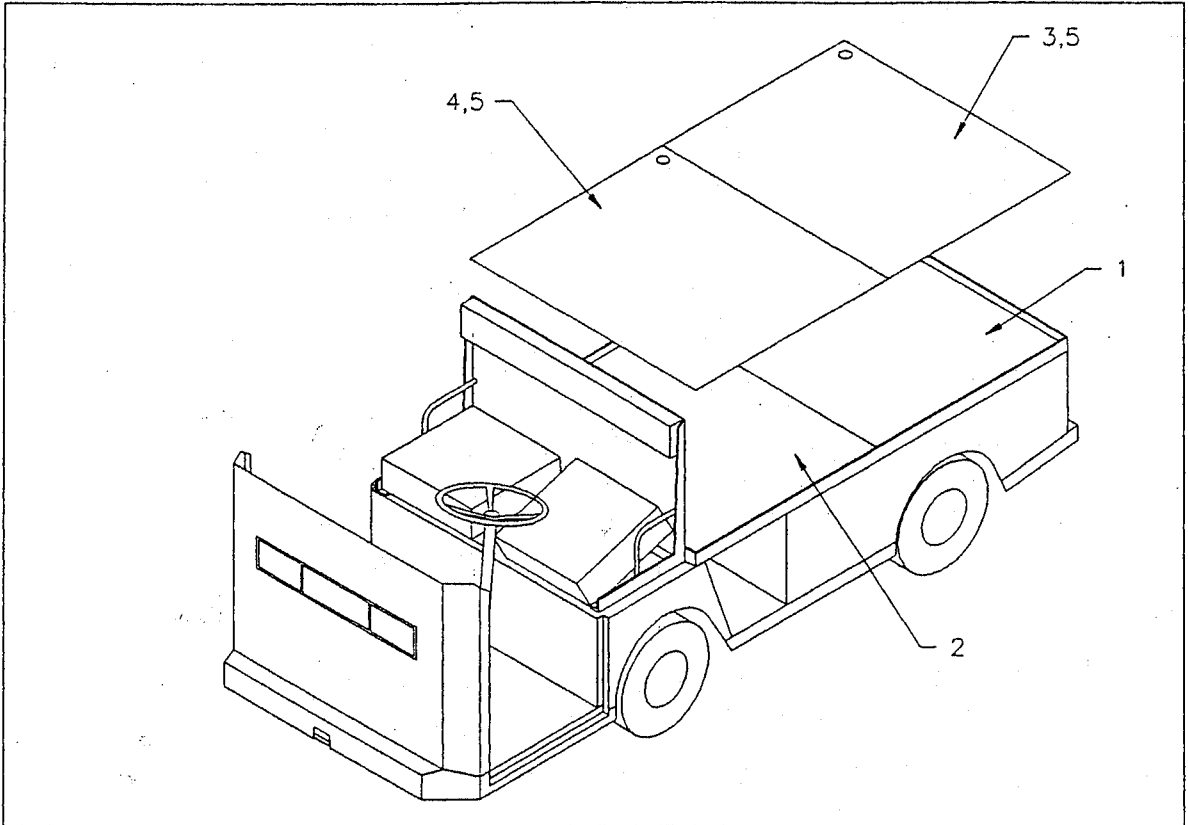

OPTIONS8.DWG

OPTIONAL PARTS-Cont'd			
Deck Cover, Diamond Plate, 2-Pc., Std. Bed			
Item No.	Part No.	Description	Qty
	90-440-45	Kit, Diamond Cover, Std Bed, Black (does not include #1 & 2)	1
1	90-444-20	Deckboard, 41" x 38-1/2" x 5/8"	1
2	90-444-30	Deckboard, 41" x 36-5/8" x 5/8"	1
3	90-440-46	Deck Cover, Diamond Plate, Rear	1
4	90-440-47	Deck Cover, Diamond Plate, Front	1
5	88-607-09	Rivet, 1/4" x 1/2" Starpin	16
*	00-210-23	Deck Support	1
*	88-065-08	Screw, 1/4NC x 5/8" Phillips Truss Hd	3
*	88-069-87	Nut, 1/4NC Keps	3
Side Panels, 12"			
	90-545-63	Kit, 12" Side Panels & Tailgate, Orange	1
	90-545-64	Kit, 12" Side Panels & Tailgate, Specify Color	1
7	00-210-38	Side Panel, Left, 12" (unpainted)	1
8	00-210-37	Side Panel, Right, 12" (unpainted)	1
9	00-210-58	Tailgate, 12" (unpainted)	1
10	00-210-78	Deck Angle, Lower Rear (unpainted)	1
11	00-210-77	Deck Angle, Top Rear (unpainted)	1
12	30-550-55	Chain, 12-1/4" Long	2
13	30-551-00	S-Hook	2
14	30-551-10	Hook, Tailgate Chain	2
15	00-210-39	Tailgate Pivot	2
16	88-082-11	Bolt, 5/16NC x 1" Carriage	8
17	88-088-60	Washer, 5/16" Cut	8
18	88-089-81	Locknut, 5/16NC	8
*	88-065-08**	Screw, 1/4NC x 5/8" Phillips Truss Hd	23
*	88-069-81**	Locknut, 1/4NC	23

* Not shown in illustration.

** Hardware used to mount the left and right side panels to the frame and to the seat back. Also, to mount the two rear deck angles.

SECTION 4

OPTIONAL PARTS-Cont'd

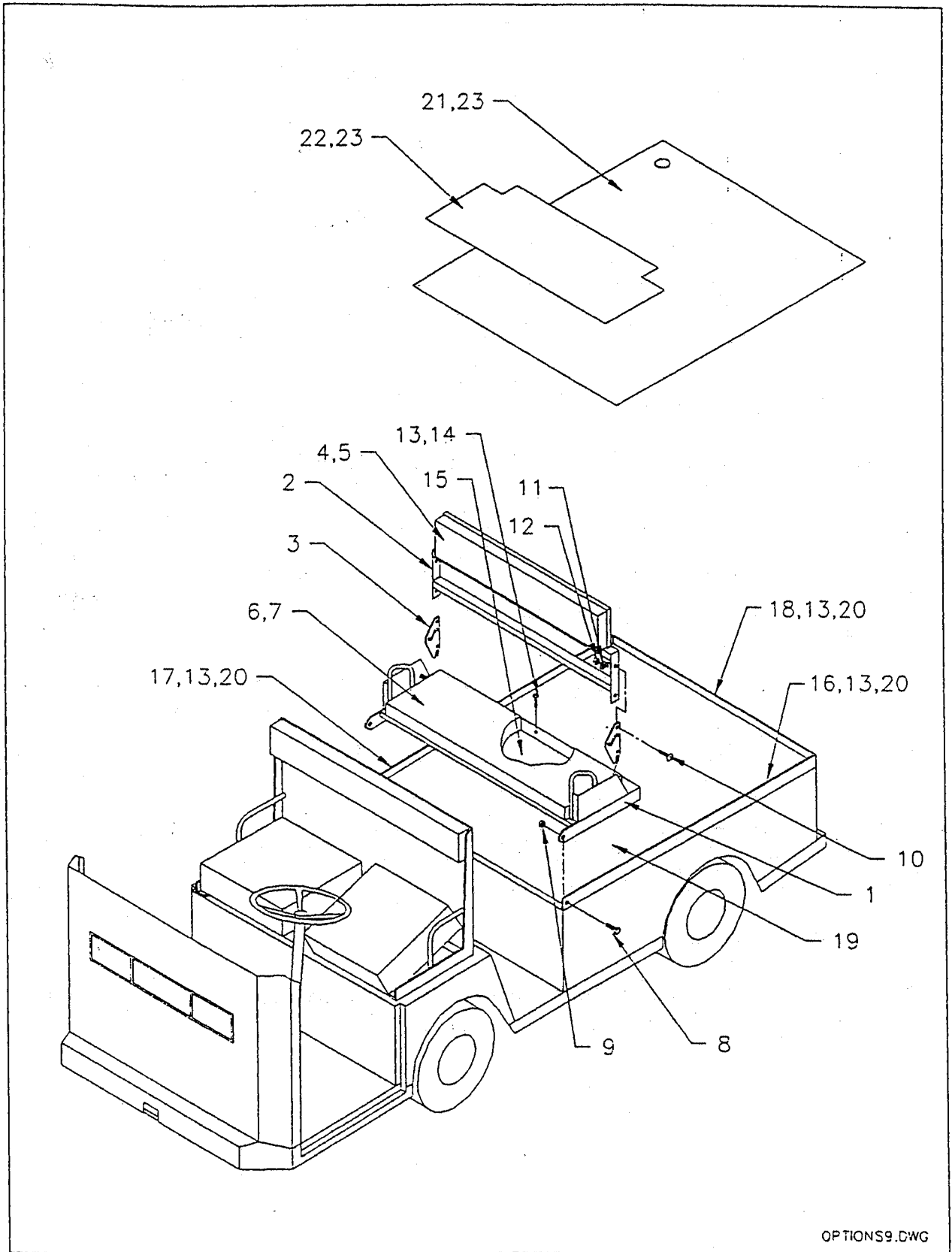

OPTIONS9.DWG

OPTIONAL PARTS-Cont'd			
Foldaway 2nd Seat			
Item No.	Part No.	Description	Qty
	90-010-59	Kit, Foldaway 2nd Seat, Specify Color	1
	90-010-60	Kit, Foldaway 2nd Seat, Black	1
1	00-210-92	Seat Base Frame	1
2	00-210-93	Seat Back Frame	1
3	00-210-91	Seat Pivot Plate	2
4	90-179-00	Backrest, Black	1
5	88-837-11	Screw, #14 x 1" Phillips Sheet Metal	8
6	90-178-00	Seat Cushion, 12" x 40", Black	1
7	88-837-14	Screw, #14 x 1-1/2" Phillips Sheet Metal	6
8	88-100-11	Bolt, 3/8NC x 1" Hex Hd	2
9	88-109-81	Locknut, 3/8NC	2
10	88-082-11	Bolt, 5/16NC x 1" Carriage	4
11	88-088-82	Lockwasher, 5/16"	4
12	88-089-80	Nut, 5/16NC	4
Deckboard, Foldaway 2nd Seat			
13	88-065-09	Screw, 1/4NC x 3/4" Phillips Truss Hd	17
14	88-069-88	T-Nut, 1/4NC x 5/16", 4 Prong	3
15	90-440-36	Deckboard, Foldaway 2nd Seat	1
16	03-210-21	Side Rail, Left (unpainted)	1
17	03-210-20	Side Rail, Right (unpainted)	1
18	00-210-15	Rear Rail (unpainted)	1
19	90-440-37	Deckboard, Foldaway Seat, 58" x 41"	1
20	88-069-87	Nut, 1/4NC Keps	14
Deck Cover, Diamond Plate, Foldaway 2nd Seat			
	90-440-61	Kit, Diamond Plate Deck Cover, Foldaway Seat	1
21	90-440-48	Deck Cover, 41" x 16-3/8", Black	1
22	90-440-49	Deck Cover, 41" x 58", Black	1
23	88-607-09	Rivet, 1/4" x 1/2" Starnpin	13

** Not shown in illustration.

SECTION 4

OPTIONAL PARTS-Cont'd

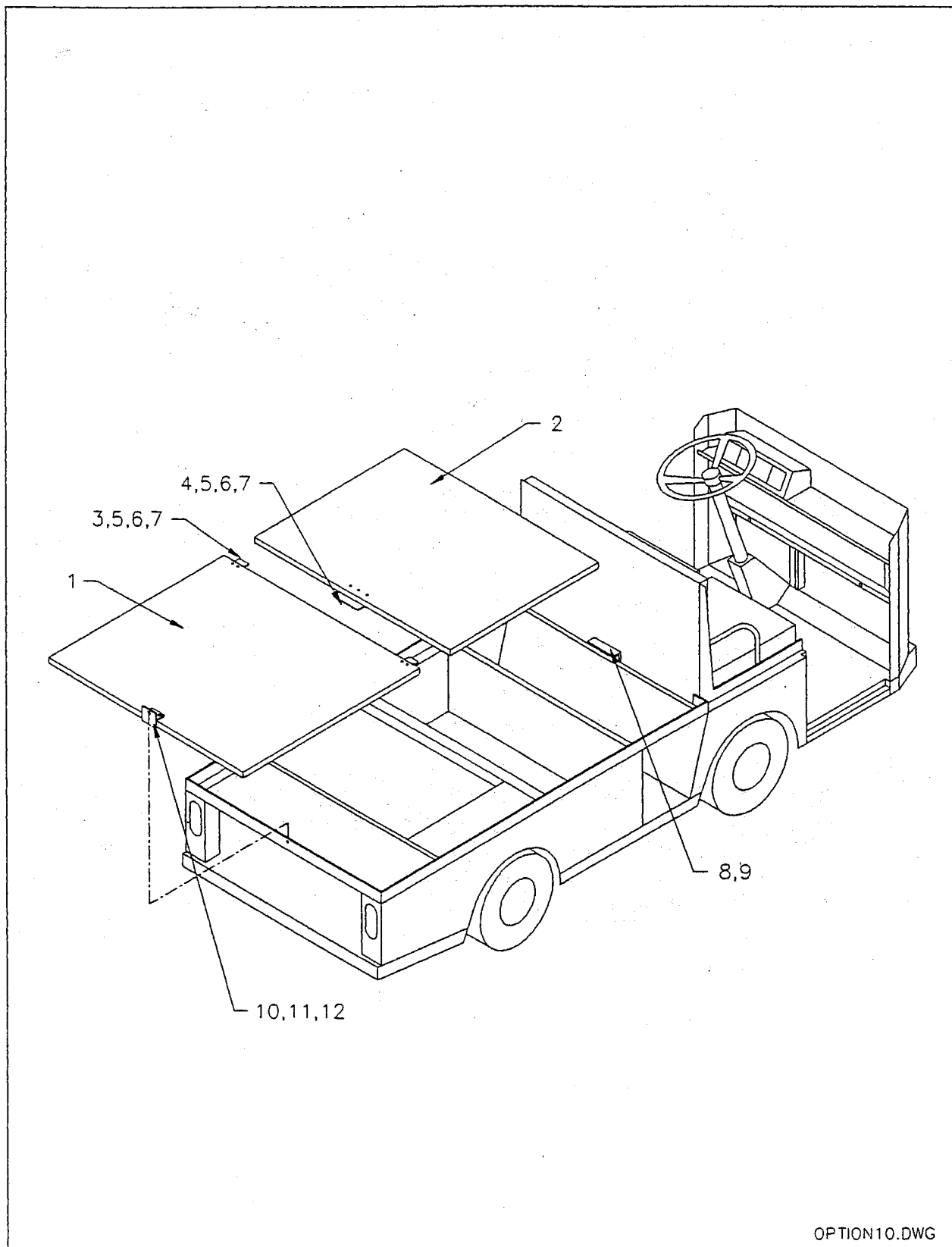

OPTION10.DWG

OPTIONAL PARTS-Cont'd			
Deckboard, Lockable, 2 Piece			
1	90-444-20	Deckboard, 41" x 38-1/2", Black	1
2	90-444-30	Deckboard, 41" x 36-5/8", Black	1
3	03-210-25	Plate, Deck Side Lock	2
4	03-210-24	Plate, Deck Center Lock	1
5	88-082-13	Bolt, 5/16NC x 1-1/4" Carriage	7
6	88-088-62	Lockwasher, 5/16"	7
7	88-089-80	Nut, 5/16NC	7
8	03-210-23	Angle, Forward Deck Lock	1
9	88-737-08	Rivet, 3/16" x 5/8"	3
10	03-210-28	Deck Lock, Rear	1
11	88-065-08	Screw, 1/4NC x 5/8" Phillips Truss Hd	2
12	88-069-88	T-Nut, 1/4NC x 5/16", 4 Prong	2

SECTION 4

OPTIONAL PARTS-Cont'd

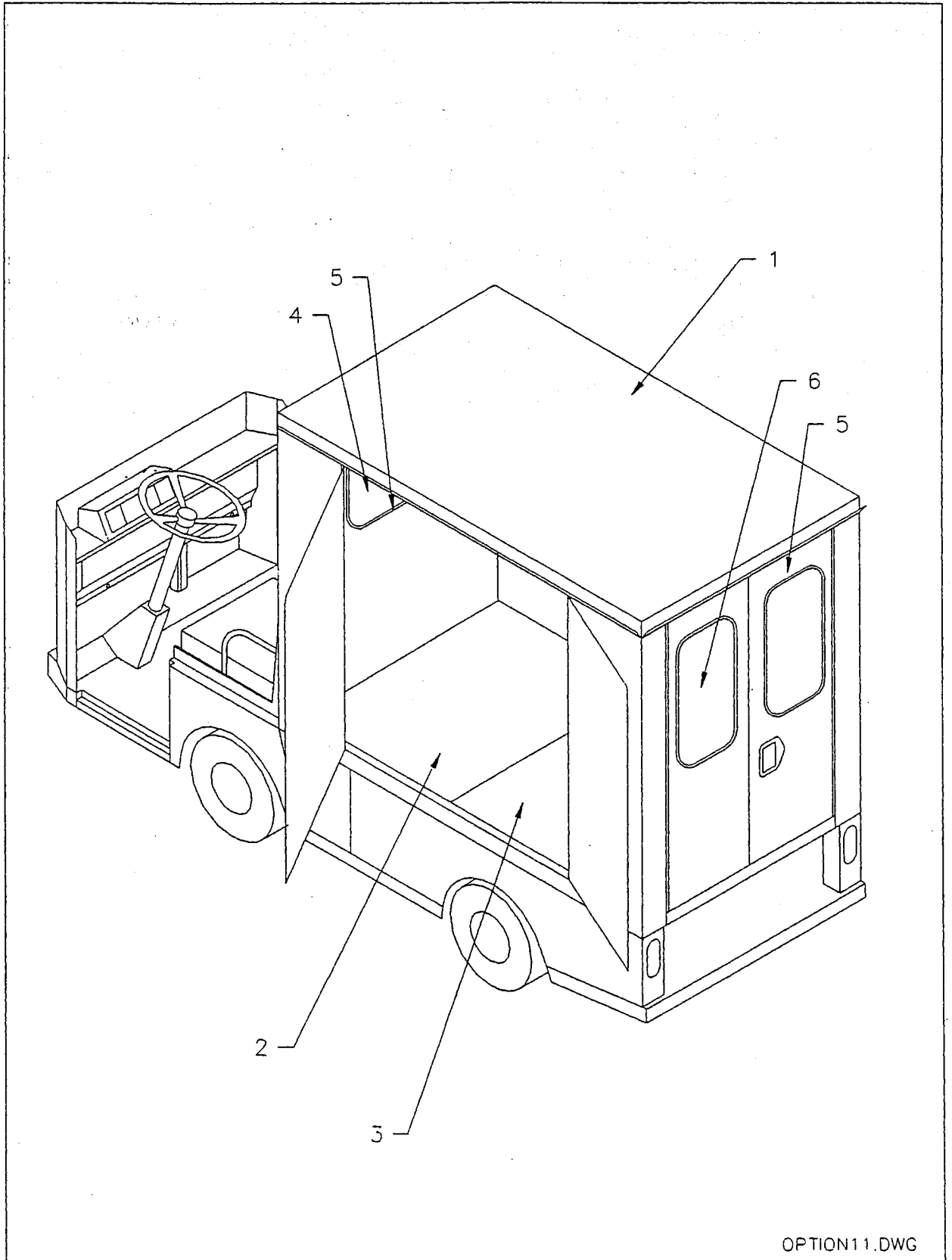

OPTION11.DWG

OPTIONAL PARTS-Cont'd			
Box, Double Doors, Side & Rear Windows			
	91-333-60	Kit, Box, Doors Lt & Rr, w/Glass, Orange	1
	91-333-61	Kit, Box, Doors Lt & Rr, w/Glass, Specify Color	1
1	90-333-02	Box, Doors Left & Rear, Glass Front & Rear (unpainted)	1
2	90-471-00	Deckboard, Front, 40" x 35-1/2"	1
3	90-472-00	Deckboard, Rear, 40" x 38-3/4"	1
4	90-850-10	Window, 13-7/8" x 31-7/8"	1
5	98-310-00	Window Channel, Rubber	19 ft
6	90-851-00	Window, Rear, 12" x 18"	2
**	88-080-11*	Bolt, 5/16NC x 1" Hex Hd	6
**	88-088-62*	Lockwasher, 5/16"	6
**	88-089-80*	Nut, 5/16NC	6
**	00-210-23	Angle, Deck Support	1
**	88-065-08	Screw, 1/4NC x 5/8" Phillips Truss Hd	3
**	88-069-87	Nut, 1/4NC Keps	3

* Hardware used to mount box to vehicle frame.

** Not shown in illustration.

SECTION 4

OPTIONAL PARTS-Cont'd

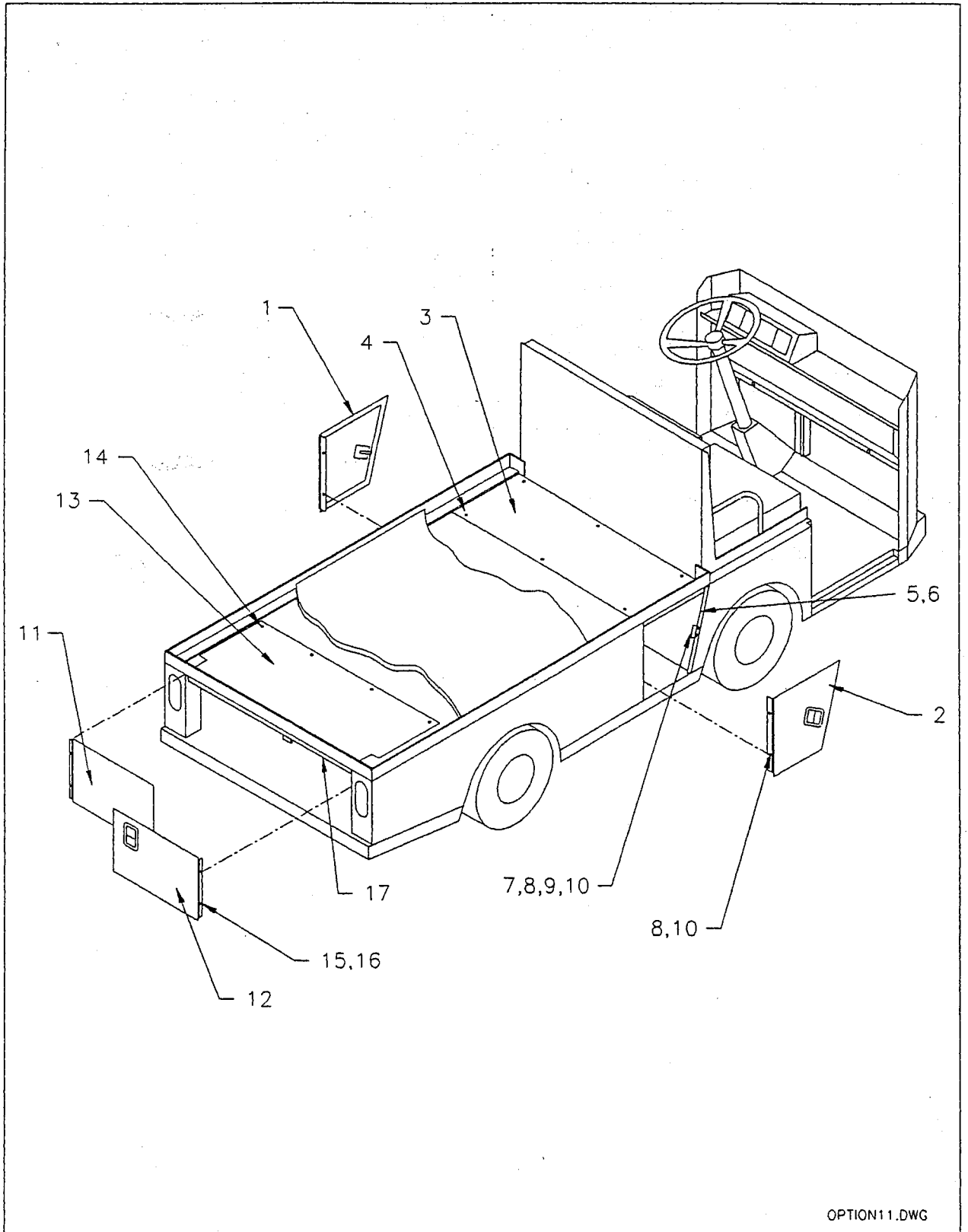

OPTIONAL PARTS-Cont'd			
Tools Box Doors, Side			
	91-340-62	Kit, Side Tool Box Doors, Orange	1
	91-340-64	Kit, Side Tool Box Doors, Specify Color	1
1	02-210-12	Tool Box Door, Left (unpainted)	1
2	02-210-13	Tool Box Door, Right (unpainted)	1
3	02-210-15	Tool Box Top, Black	1
4	88-737-08	Rivet, 3/16" x 5/8"	6
5	02-210-14	Door Stop, Tool Box Door	2
6	88-837-09	Screw, #14 x 3/4" Phillips Sheet Metal	6
7	02-210-16	Catch, Door Latch	2
8	88-065-08	Screw, 1/4NC x 5/8" Phillips Truss Hd	8
9	88-068-61	Washer, 1/4" SAE	2
10	88-069-87	Nut, 1/4NC Keps	8
**	98-451-10	Tape, Weather Strip, 3/4" x 9/16"	5 ft
Tools Box Doors, Rear			
	91-340-61	Kit, Tool Box Doors, Rear, Orange	1
	91-340-65	Kit, Tool Box Doors, Rear, Specify Color	1
11	02-210-21	Tool Box Door, Rear Left (unpainted)	1
12	02-210-64	Tool Box Door, Rear Right (unpainted)	1
13	02-210-62	Rear Tool Box Top, Black	1
14	88-737-08	Rivet, 3/16" x 5/8"	4
15	88-065-09	Screw, 1/4NC x 3/4" Phillips Truss Hd	4
16	88-069-87	Nut, 1/4NC Keps	4
**	98-451-11	Tape, Seal, 1" x 3/8"	3 ft

** Not shown in illustration.

OPTIONAL PARTS-Cont'd

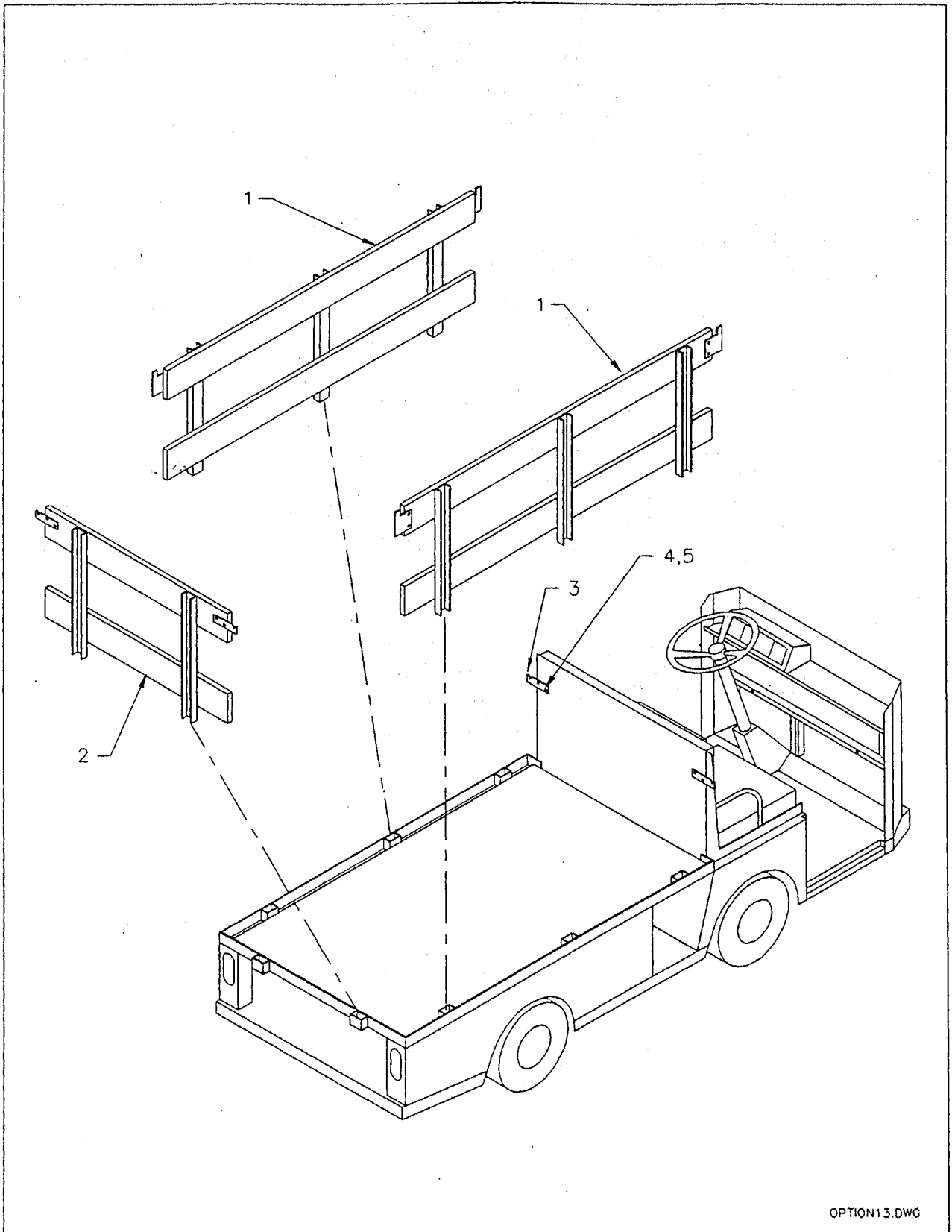

OPTION13.DWG

OPTIONAL PARTS-Cont'd			
Stake Sides, Standard Bed			
	90-545-61	Kit, Stake Sides, 2 Passenger, Std Bed	1
1	90-545-02	Side Gate, Black	1
2	90-545-01	End Gate, Black	1
3	90-540-00	Gate Hook	2
4	88-065-08	Screw, 1/4NC x 5/8" Phillips Truss Hd	4
5	88-069-87	Nut, 1/4NC Keps	4

SECTION 4

OPTIONAL PARTS-Cont'd

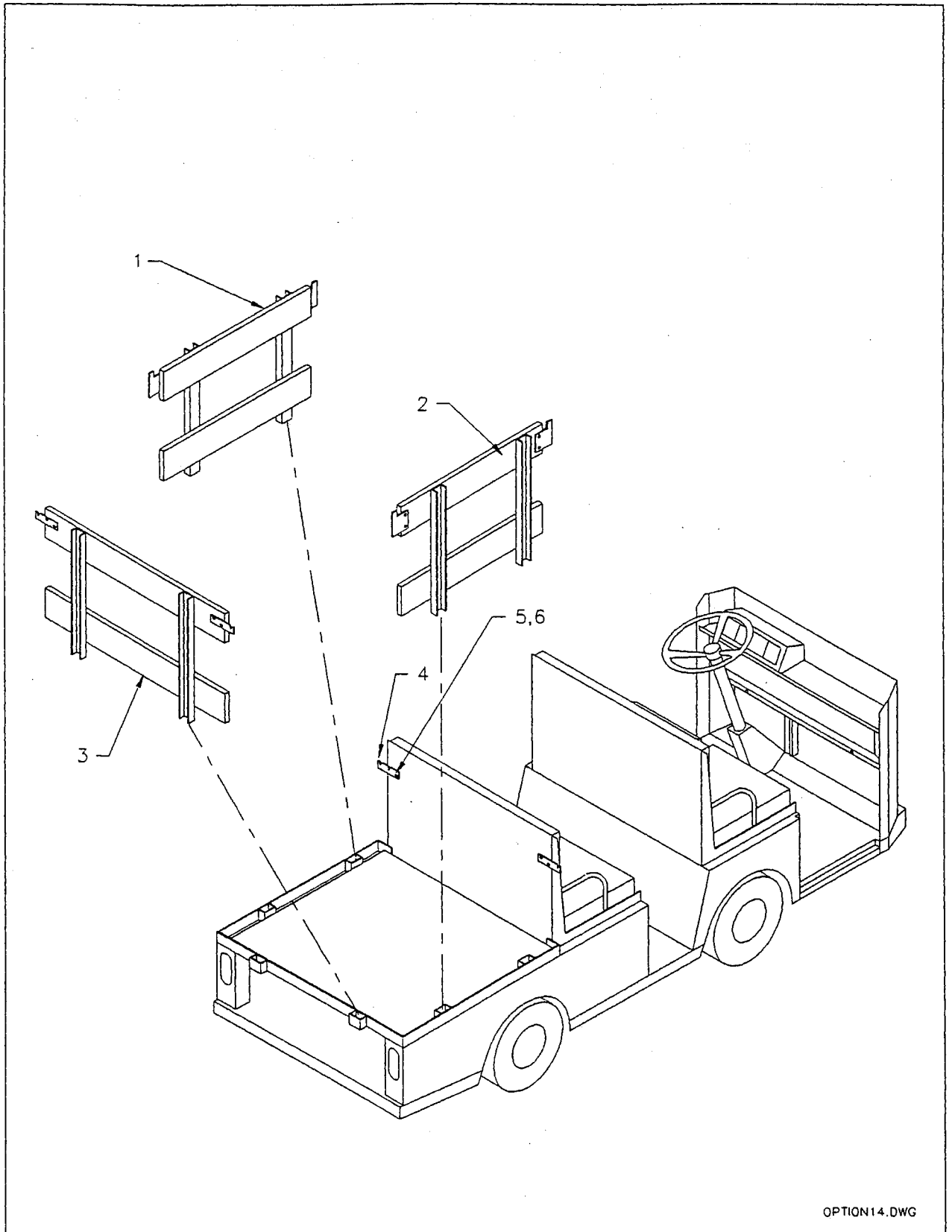

OPTION14.DWG

OPTIONAL PARTS-Cont'd			
Stake Sides, Fixed 2nd Seat			
	90-545-62	Kit, Stake Sides, 4 Passenger	1
1	90-545-03	Side Gate, Left, Black	1
2	90-545-04	Side Gate, Right, Black	1
3	90-545-01	End Gate, Black	1
4	90-540-00	Gate Hook	2
5	88-065-08	Screw, 1/4NC x 5/8" Phillips Truss Hd	4
6	88-069-87	Nut, 1/4NC Keps	4

OPTIONAL PARTS-Cont'd

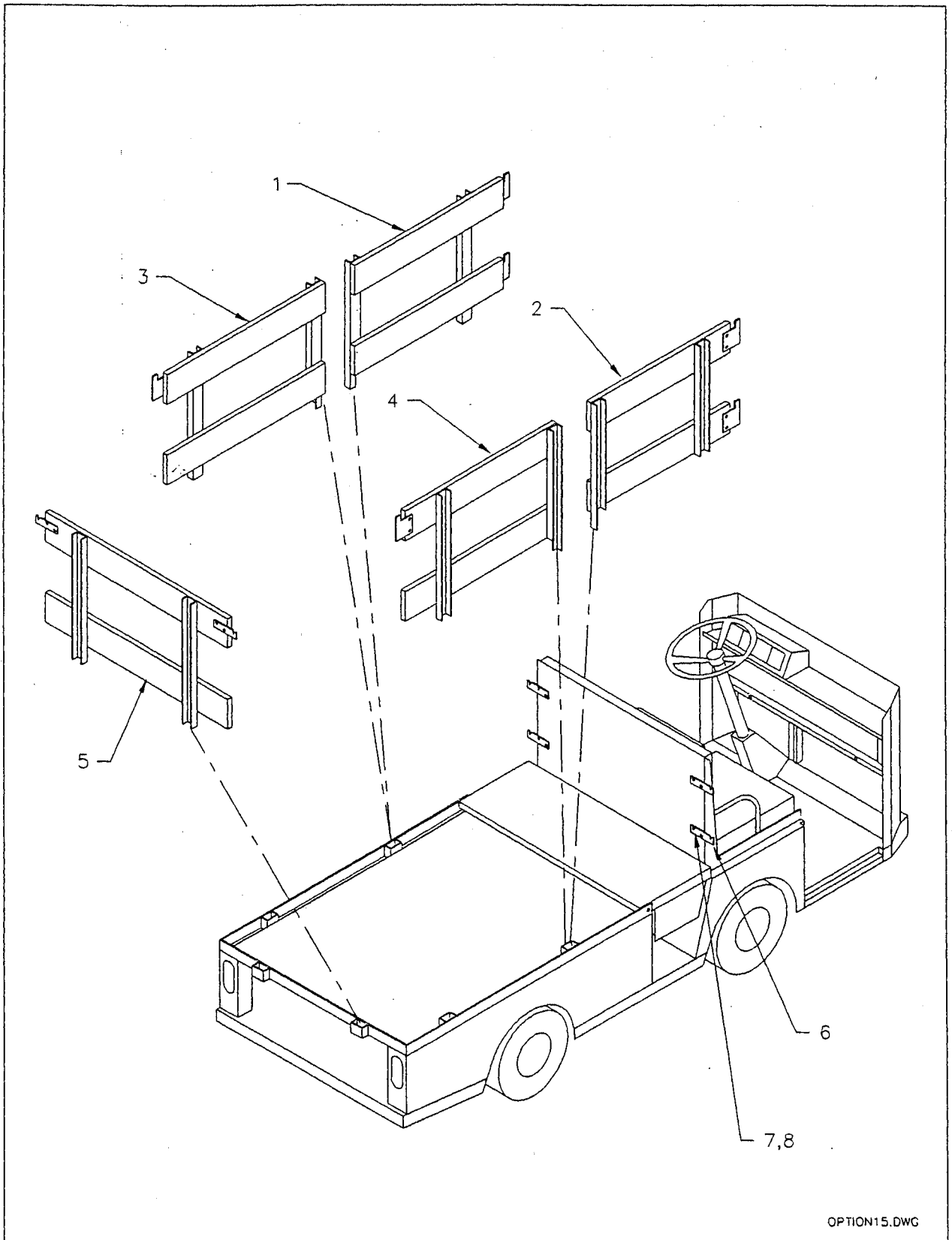

OPTIONAL PARTS-Cont'd			
Stake Sides, Foldaway 2nd Seat			
1	90-545-12	Side Gate, Front Left, Black	1
2	90-545-13	Side Gate, Front Right, Black	1
3	90-545-14	Side Gate, Rear Left, Black	1
4	90-545-15	Side Gate, Rear Right, Black	1
5	90-545-01	End Gate, Black	1
6	90-540-00	Gate Hook	4
7	88-065-08	Screw, 1/4NC x 5/8" Phillips Truss Hd	8
8	88-069-87	Nut, 1/4NC Keps	8

OPTIONAL PARTS-Cont'd

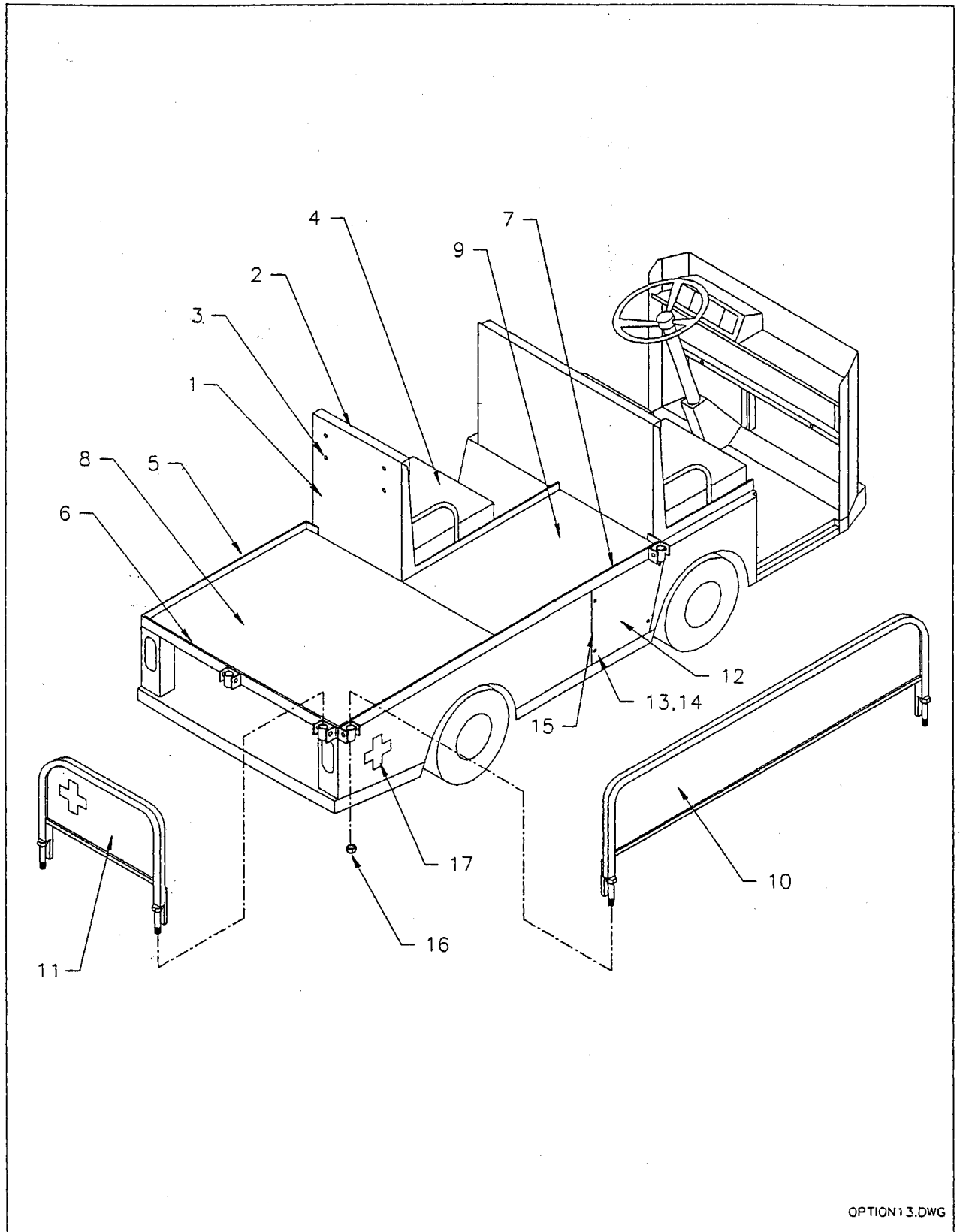

OPTION13.DWG

OPTIONAL PARTS-Cont'd			
Nurse's Seat, Black Cushions			
1	00-210-51	Nurse's Seat Frame (unpainted)	1
2	90-000-00	Backrest, 6-1/8" x 16-3/4", Black	1
3	88-837-13	Screw, #14 x 1-1/4" Phillips Sheet Metal	4
4	90-191-00	Seat Cushion, 17" x 18", Black	1
***	88-065-08*	Screw, 1/4NC x 5/8" Phillips Truss Hd	4
***	88-069-87*	Nut, 1/4NC Keps	4
Deck, Galvanized, Ambulance			
5	00-610-07	Deck Rail, Left (unpainted)	1
6	00-610-06	Deck Rail, Rear (unpainted)	1
7	00-610-05	Deck Rail, Right (unpainted)	1
8	90-440-72	Deckboard, Galvanized, Rear	1
9	90-440-70	Deckboard, Galvanized, Front	1
***	88-065-08**	Screw, 1/4NC x 5/8" Phillips Truss Hd	13
***	88-065-09**	Screw, 1/4NC x 3/4" Phillips Truss Hd	4
***	88-069-87**	Nut, 1/4NC Keps	17
Ambulance Safety Panels			
10	00-201-77	Safety Panel, Right (unpainted)	1
11	00-201-78	Safety Panel, Rear (unpainted)	1
12	00-210-53	Panel, Right Side	1
13	88-065-08	Screw, 1/4NC x 5/8" Phillips Truss Hd	4
14	88-069-87	Nut, 1/4NC Keps	4
15	98-451-20	Tape, Foam, 1/8" x 1/2"	3 ft
16	88-149-81	Locknut, 1/2NC	4
17	94-324-00	Decal, Cross Emblem, Red	4

* Hardware used to mount the nurse's seat to the vehicle frame.

** Hardware used to mount the deck rails to the vehicle frame.

*** Not shown in illustration.



TAYLOR-DUNN[®]
Commercial and Industrial Vehicles Since 1949



**The Best Way To Go About
Your Business**