

OPERATION AND MAINTENANCE MANUAL WITH PARTS LIST

MODEL:	B 2-10
SERIAL NO. :	71123 - 80552
YEAR:	01/83 - 12/85
MANUAL NO. :	MB-210-01

- IMPORTANT -

READ AND FOLLOW INSTRUCTIONS GIVEN
IN SAFETY & OPERATIONS AND THOSE
SECTIONS RELATED TO YOUR SERVICE
AND REPAIR RESPONSIBILITIES



TAYLOR-DUNN

Commercial and Industrial Vehicles Since 1949

2114 W. Ball Rd., Anaheim, CA 92804 (714)956-4040 Fax (714)956-0504
Mailing Address: P.O. Box 4240, Anaheim, California 92803

91132
IMPORTANT INFORMATION

This vehicle conforms to applicable portions of ANSI B56.8 (American National Standard Personnel and Burden Carriers). This manual is designed for use by Vehicle Operators and Service Personnel alike. Throughout the manual, there are various WARNINGS, CAUTIONS, and NOTICES which must be carefully read to help reduce the possibility of personal injury. Maintenance personnel must understand that if a service procedure or method is used that is not recommended by Taylor-Dunn, it then becomes the personal responsibility of the person performing the work to first satisfy himself that neither his safety, the safety of others, or the safety of the vehicle will be endangered. Ansi B56.8 applies to only those vehicles with Serial Numbers dated after July 31, 1982.

Definitions of the three terms are as follows:

WARNING - There is a potential for injury to yourself and others.

CAUTION - There is a potential for damage to the vehicle.

NOTE - Specific information clarifying or giving the reason for a particular maintenance or service procedure.

Before operating your Taylor-Dunn vehicle, it is your responsibility to read, understand and follow the safety and operating instructions contained in this manual to help ensure your safety and comfort. If this car is to be used for rental purposes, it is your responsibility to explain to the operator about the various controls and vehicle operating characteristics. Equally important is the operators need to know the basic rules required for safe operation of the vehicle in day to day usage. Sections 5 and 6 of ANSI B56.8 have been inserted in Section 3 page 3 of this manual for your specific operating guidelines.

1. Vehicle is to be operated only by qualified persons and only in designated areas.
2. Vehicle will not be started until all occupants are seated.
3. Occupants must remain seated while vehicle is in motion.
4. Arms, legs and feet must be kept inside while vehicle is in motion.
5. Slow down making a turn.
6. Drive slowly straight up and down inclines.
7. Set parking brake before leaving vehicle.
8. Forward/Reverse lever must be in the correct position for direction of travel desired.

WARNING: FAILURE TO COMPLY WITH ABOVE INSTRUCTIONS COULD RESULT IN INJURY TO THE VEHICLE OCCUPANTS, BYSTANDERS AND TO PROPERTY.

071133

TABLE OF CONTENTS
B 2-10

CONTENTS	SECTION
INSPECTION, SAFETY AND INTRODUCTION	1
OPERATING INSTRUCTIONS	3
MAINTENANCE GUIDE CHECKLIST	4
LUBRICATION DIAGRAM	5
TROUBLE SHOOTING	6
BATTERIES	7
CHARGERS	8
VEHICLE WIRING DIAGRAM	9
MAINTENANCE PROCEDURES, SERVICE AND ADJUSTMENTS, PARTS ILLUSTRATIONS AND LISTINGS	
FRONT AXLE, STEERING AND TIRES	10
STEERING WORM ASSEMBLY	10
BELT DRIVE, REAR AXLE AND POWER TRACTION	11
BRAKE SYSTEM AND CONTROL LINKAGE	12
G.E. MOTORS AND PARTS LIST	13
SPEED CONTROLLER (PWR-TRON) & ACCELERATOR LINKAGE	14
RECOMMENDED SPARE PARTS	15
HOW TO ORDER SPARE PARTS	16
BODY AND TRIM (OPTIONAL ITEMS)	17

INSPECTION, SAFETY AND INTRODUCTION
ARRIVAL INSPECTION CHECKLIST

Visual Inspection should be made to determine that the truck has remained in good condition during transit. If any damage is found, the details should be noted on the delivery receipt immediately. After delivery the truck should be most carefully checked for HIDDEN DAMAGE. Any concealed damage not noted on the delivery receipt should be reported, in writing, to the delivering carrier within 48 hours.

The following checklist has been prepared to aid you during arrival and inspection of your vehicle.

- A. Open all packages and examine any accessories which may be shipped detached from vehicle.
- B. Examine wiring for visible evidence of damage. Check all connections to insure that none have loosened during transit.
- C. Check all battery connections and electrolyte level in each cell.
- D. Inspect battery charger in accordance with manufacturers installation instructions.
- E. Check tires for damage and proper inflation. Check wheel lugs to insure they are tight.
- F. If vehicle is equipped with hydraulic brakes, check hydraulic lines for evidence of damage.
- G. Check brake fluid level in master cylinder.
- H. Examine entire vehicle for damage such as dents or cracks.
- I. Check operation of controls to see that they are working freely.

Upon completion of the Visual Inspection, an operational test should be made after a thorough review of Sections 1, 2 and 3.

INSPECTION, SAFETY AND INTRODUCTION
SAFETY

The safe and satisfactory use of any vehicle is a responsibility shared by many persons.

As the manufacturer, we feel that it is our responsibility to emphasize vehicle characteristics and make safety recommendations regarding those characteristics. That is the primary purpose of this portion of the manual.

Persons who operate this vehicle need to be aware of, and to observe, the safe driving rules established in their locality, and need also to be aware of the vehicle operating characteristics and safety recommendations of the manufacturer, to assist them in exercising the judgement necessary to prevent injury to themselves or to others.

IMPORTANT: Persons who service and maintain the vehicle need to be aware of how their activities relate to safe vehicle operation, and of potential hazards involved in the service and maintenance processes, to assist them in applying sensible judgement to those processes.

STEERING: This vehicle has a very small minimum turning radius, and low ratio steering leverage.

CAUTION: These characteristics, so desirable for maneuverability at slow speeds, require that great care be exercised at high speeds to avoid turning so sharply that one or more wheels lose contact with the ground, or that the vehicle is caused to overturn. Be especially careful while traveling on an incline. Avoid sharp turns, even at slow speeds.

SPEED: This vehicle is designed to attain its maximum safe operating speed on level ground. That speed can easily be exceeded when traveling down hill. If this is allowed to occur, vehicle stability and braking performance become unpredictable. **CAUTION: DO NOT exceed, under any circumstances, the maximum design speed of the vehicle.**

CONTROLS: Bring the vehicle to a complete standstill before operating the forward/reverse switch to change direction of travel. Operation of this control while the vehicle is in motion can result in complete loss of power. **DO NOT** use the accelerator to hold the vehicle at a standstill on an incline. Use only the brakes to hold the vehicle at rest while on a hill. **CAUTION:** Intentional/unintentional mis-use of controls could result in an accident.

BRAKES The brake system relies on contact of rear tires with the ground for effectiveness. As tire to ground contact is reduced, braking effect is reduced. While driving, the operator must consider terrain, speed and steering maneuvers to prevent tires from losing contact with the ground, with consequent reduction of braking action.

INSPECTION, SAFETY AND INTRODUCTION continued
SAFETY

MAINTENANCE: Many operating characteristics relate to maintenance in ways which are not readily obvious. Those maintenance characteristics most closely related to vehicle operating safety are indicated in Section 3 & 4.

CAUTION: Also to be considered is the safety of personnel who perform service and maintenance duties. Two characteristics need special emphasis.

1. This electric vehicle does not "idle" noisily, is never "out of gear", and is set into motion whenever the battery to the motor circuit is closed, intentionally or otherwise. Whenever practical disconnect battery leads to avoid unintentional starting of the motor during servicing or maintenance.
2. Batteries emit gasses which can be explosive, especially while they are being charged. Personnel who are involved with servicing vehicles, or maintaining vehicles, need to be made familiar with this hazard. A detailed explanation is contained in Section 7.

CAUTION:

1. When performing maintenance on any part of the vehicle electrical system, disconnect main battery leads, place forward/reverse switch in neutral. Remove key from keylock in dash panel.
2. Never replace a circuit fuse with one having a higher rating than the original equipment fuse. Fuses have been selected to provide full circuit protection for all operating conditions. A FUSE WILL ONLY BLOW DUE TO A SHORT CIRCUIT. Therefore, always locate and correct the cause of short-circuit before replacing a blown fuse. Using a fuse of higher rating is an UNSAFE PRACTICE and could cause serious damage to equipment.

INTRODUCTION

This vehicle is designed to be driven on smooth surfaces in and around industrial plants, nurseries, institutions, motels, mobile home parks and resorts. It is not designed to be driven on the public highways. It is not designed to go in excess of 15 mph on level surfaces or downhill. Speeds in excess of this may result in steering difficulty and possible loss of vehicle control. Vehicle is not designed to be towed in excess of 15 mph.

SERIAL NO.

The model number and serial number are on a decal attached to the cowl panel left of the steering column. In ordering parts or referring to your unit, please use these numbers. Replacement parts can be purchased directly from your local authorized dealer.

OPERATING INSTRUCTIONS

The controls on your Taylor-Dunn vehicle have been designed and located for convenience of operation and efficient performance. Before driving your vehicle for the first time, familiarize yourself with each of the controls. Read the following instructions and with power OFF, operate each control.

STEERING

The steering wheel and steering system is similar to automotive types. Turn the steering wheel to the right (clockwise) for a right turn and left (counterclockwise) for a left turn.

KEY LOCK

Your vehicle is equipped with a keyed lock located on the instrument panel. It is designed to lock the switch in the neutral position only. The key will remove from the lock in the locked position (neutral) only.

AUTOMATIC DEADMAN BRAKE

This system is standard on your vehicle and acts as a park brake feature when operator arises from seat. Seat will rise, setting park brake and disconnecting battery/motor circuit.

SERVICE BRAKE (FOOT)

The brake pedal is designed and located for right foot operation. It is the pedal located to the left of the accelerator pedal. It functions the same as the brake pedal in your automobile. Depressing the pedal applies the braking action. The greater the effort applied to the pedal with your foot, the greater the braking action to your vehicle. Removing your foot from the pedal allows immediate release of the braking action to your vehicle.

FORWARD/REVERSE SWITCH

The forward/reverse switch is located on the instrument panel. It is a rocker type switch. Depressing the upper part places the vehicle in forward. Depressing the lower portion full downward places vehicle in reverse. Center position is off. CAUTION: The forward/reverse switch serves the same purpose as the transmission in your automobile. Treat it with the same respect and care. DO NOT SHIFT from forward to reverse or vice-versa while the vehicle is in motion, especially near top speed, causes great strain to your entire vehicle and will eventually cause severe damage, complete loss of power and could cause an accident.

ACCELERATOR PEDAL

The accelerator pedal is located to the right of the brake pedal. It is designed for right foot operation similar to your automobile. Depressing the pedal turns the power on to the motor. It also controls the amount of power delivered to the motor. When driving your vehicle you will be able to feel full power when accelerator is fully depressed and minimum power when only partially depressed. You will have the same control of power in both directions of travel. Your forward/reverse switch determines the direction of travel and your accelerator pedal controls the speed.

OPERATING INSTRUCTIONS continued

HORN BUTTON

The horn button is located on the instrument panel. Depressing button sounds horn. Releasing button will immediately silence horn.

LIGHT SWITCH

The light switch that controls headlamps and taillamps is located in the instrument console.

BATTERY CHARGER

Refer to SECTION 8 for proper instructions to operate your battery charger.

STANDARD OPTIONAL ACCESSORIES

WINDSHIELD WIPER

On vehicles equipped with electric windshield wipers the control switch is located in the instrument panel.

DIRECTION SIGNALS

On vehicles equipped with directional turn signals the control is located on the steering column. Move the control lever in the direction you will be turning your steering wheel to signal the direction you intend to turn your vehicle. Indicating lamps are located within the turn signal control for your convenience.

The directional turn signal also serves as an emergency flasher control by pulling the control lever outward away from steering column when in neutral position.

SPECIAL ACCESSORIES

Refer to the appropriate section of this manual for separate operating instructions pertaining to any special feature or accessory your vehicle may have.

OPERATING YOUR VEHICLE

To put your vehicle into operation; sit on seat, turn key on (clockwise). Select direction you wish to travel by activating forward reverse switch then slowly depress accelerator pedal until vehicle is moving at the desired speed. Steer vehicle as required, utilizing the foot brake and accelerator to control your speed as desired.

CAUTION:

DO NOT "hold" vehicle at a standstill on a hill or incline using accelerator only. Continued "stalled" condition as described will damage motor and electrical controls. Use your foot brake to hold the vehicle on a hill safely.

CAUTION:

When you leave your vehicle, it is best to always place forward/reverse switch in neutral position and remove key.

Drive safely and enjoy your Taylor-Dunn vehicle.

OPERATING RESPONSIBILITIES
AMERICAN NATIONAL STANDARD PERSONNEL AND BURDEN CARRIERS
ANSI B 56.8-1981
SECTION 5
OPERATING RULES AND PRACTICES

501 OPERATOR QUALIFICATIONS

Only trained and authorized operators shall be permitted to operate a Personnel and Burden Carrier. Operators of Personnel and Burden Carriers shall be qualified as to visual, auditory, physical, and mental ability to safely operate the equipment according to Section 5 and all other applicable parts of this standard.

502 PERSONNEL AND BURDEN CARRIER OPERATORS' TRAINING

(a) The carrier owner, lessee, or employee of the carrier operator shall conduct an operators' training program for the carrier operators.

(b) Successful completion of the operators' training program shall be required by the owner, lessee, or employer of the carrier operator before operation of the Personnel and Burden Carrier by any operator.

(c) An effective operator's training program should center around user company's policies, operating conditions, and their Personnel and Burden Carrier by any operator.

(d) Information on operator training is available from several sources, including carrier manufacturers.

(e) The carrier owner, lessee, or employer of the carrier operator should include in the operators' training program the following:

(1) Careful selection of the operators, considering physical qualifications, job attitude and aptitude.

(2) Emphasis on safety of stock, equipment operator, and other employees.

(3) General safety rules contained in this standard and the additional specific rules determined by the carrier owner, lessee, or employer of the carrier operator in accordance with this standard, and why they were formulated.

(4) Introduction of equipment, control locations and functions, and explanation of how they work when used properly and when used improperly; and ground and floor conditions, grade, and other conditions of the environment in which the Personnel and Burden Carrier is to be operated.

(5) Operational performance tests and evaluations during, and at completion of the program

(6) Rules of the employer and any applicable labor contract governing and dealing with discipline of employees for violation of employer's rules, and including safety rules.

503 OPERATOR RESPONSIBILITY

Operators of Personnel and Burden Carriers shall abide by the following safety rules and practices in 504, 505, 506, and 507.

504 GENERAL

(a) Safeguard the pedestrians at all times. Do not drive carrier in a manner that would endanger anyone.

OPERATING RESPONSIBILITIES
ANSI B56.8-1981

504 GENERAL continued

(b) Riding on the carrier by persons other than the operator is authorized only when personnel seat(s) are provided. Do not put any part of the body outside the outer perimeter of the carrier.

(c) When a Personnel or Burden Carrier is left unattended, stop carrier, place directional controls in neutral, apply the parking brake, stop the engine or turn off power, turn off the control or ignition circuit, remove the key if provided, and block the wheels if machine is on an incline.

(d) A Personnel and Burden Carrier is considered unattended when the operator is 25 ft. (7.6 m) or more from the carrier which remains in his view, or whenever the operator leaves the carrier and it is not within his view. When the operator of a Personnel and Burden Carrier is dismounted and within 25 ft. (7.6 m) of the carrier still in his view, he still must have controls neutralized, and brakes set to prevent movement.

(e) Maintain a safe distance from the edge of ramps and platforms.

(f) Use only approved Personnel and Burden Carriers in hazardous locations.

(g) Report all accidents involving personnel, building structures, and equipment.

(h) Operators shall not add to, or modify, the Personnel or Burden Carrier.

(i) Fire aisles, access to stairways, and fire equipment shall be kept clear.

(j) Operators and personnel shall be warned of the hazards of long hair and loose clothing.

505 TRAVELING

(a) Observe all traffic regulations, including authorized plant speed limit. Under normal traffic conditions keep to the right. Maintain a safe distance, based on speed of travel, from the carrier or vehicle ahead; and keep the Personnel and Burden Carrier under control at all times.

(b) Yield the right of way to pedestrians, ambulances, fire trucks, or other carriers or vehicles in emergency situations.

(c) Do not pass another carrier or vehicle traveling in the same direction at intersections, blind spots, or at other dangerous locations.

(d) Keep a clear view of the path of travel, observe other traffic and personnel, and maintain a safe clearance.

(e) Slow down and sound the audible warning device at cross aisles and other locations where visibility is obstructed.

(f) Ascend or descend grades slowly.

(g) Use extra caution when operating on grades. Never turn on any grade, ramp, or incline; always travel straight up and down.

(h) Under all travel conditions the carrier shall be operated at a speed that will permit it to be brought to a stop in a safe manner.

(i) Make starts, stops, turns, or direction reversals in a smooth manner so as not to shift the load, overturn the carrier, or both.

(j) Do not indulge in stunt driving or horseplay.

(k) Slow down when approaching, or on, wet or slippery surfaces.

OPERATING RESPONSIBILITIES
ANSI B56.8-1981

505 TRAVELING continued

(l) Do not run carrier onto any elevator unless specifically authorized to do so. Approach elevators slowly, and then enter squarely after the elevator car is properly leveled. Once on the elevator, neutralize the controls, shut off power, and set brakes. It is advisable that all other personnel leave the elevator before a carrier is allowed to enter or leave.

(m) Avoid running over loose objects on the roadway surface.

(n) Prior to negotiating turns, reduce speed to a safe level, turning hand steering wheel or tiller in a smooth, sweeping motion.

506 LOADING

(a) Handle only stable or safely arranged loads. When handling off-center loads which cannot be centered, operate with extra caution.

(b) Handle only loads within the capacity of the Personnel and Burden Carrier as specified on the nameplate.

(c) Handle loads exceeding the dimensions used to establish carrier capacity with extra caution. Stability and maneuverability may be adversely affected.

507 OPERATOR CARE OF MACHINE

(a) At the beginning of each shift during which the Personnel and Burden Carrier will be used, the operator shall check the carrier condition and inspect the tires, warning devices, lights, battery, controller, brakes, and steering mechanism. If the carrier is found to be in need of repair, or in any way unsafe, or contributes to an unsafe condition, the matter shall be reported immediately to the designated authority, and the carrier shall not be operated until it has been restored to safe operating condition.

(b) If, during operating the carrier becomes unsafe in any way, the matter shall be reported immediately to the designated authority, and carrier shall not be operated until it has been restored to safe operating condition.

(c) Do not make repairs or adjustments unless specifically authorized to do so.

(d) The engine shall be stopped and the operator shall leave the carrier while refueling.

(e) Spillage of oil or fuel shall be carefully and completely absorbed or evaporated and fuel tank cap replaced before starting engine.

(f) Do not operate a carrier with a leak in the fuel system or battery.

(g) Do not use open flames for checking electrolyte level in storage batteries or liquid level in fuel tanks.

SECTION 6
MAINTENANCE PRACTICES

601 INTRODUCTION

Personnel and Burden Carriers may become hazardous if maintenance is neglected. Therefore, maintenance facilities, trained personnel, and procedures shall be provided.

MAINTENANCE PRACTICES
ANSI B56.8-1981

602 MAINTENANCE PROCEDURES

(a) Maintenance and inspection of all Personnel and Burden Carriers shall be performed in conformance with the manufacturer's recommendations and the following practices.

(b) A scheduled preventive maintenance, lubrication, and inspection system shall be followed.

(c) Only qualified and authorized personnel shall be permitted to maintain, repair, adjust, and inspect Personnel and Burden Carriers.

(d) Before leaving the Personnel and Burden Carrier, stop carrier, place directional controls in neutral, apply the parking brake, stop the engine or turn off power, turn off the control or ignition circuit, and block the wheels if carrier is on an incline.

(e) Before undertaking maintenance or repair on carrier, raise drive wheels free of floor or disconnect battery, and use chocks or other positive carrier positioning devices.

(f) Block chassis before working under it.

(g) Before disconnecting any part of the engine fuel system of a gasoline or diesel powered carrier with gravity feed fuel systems, be sure shutoff valve is closed, and run engine until fuel system is depleted and engine stops running.

(h) Before disconnecting any part of the engine fuel system of LP gas powered carriers, close the LP gas cylinder valve and run the engine until fuel in the system is depleted and the engine stops running.

(i) Operation to check performance of the Personnel and Burden Carrier shall be conducted in an authorized area where safe clearance exists.

(j) Before starting to operate the carrier:

1) Have operator in the operating position.

2) Depress clutch (or brake pedal on automatic transmission and electric carriers).

3) Place directional controls in neutral.

4) Start engine or switch electric carrier to "on" position.

5) Check functioning of directional speed controls, steering, warning devices steering, warning devices, and brakes.

(k) Avoid fire hazards and have fire protection equipment present in the work area. Do not use an open flame to check level or leakage of fuel, electrolyte, or coolant. Do not use open pans of fuel or flammable cleaning fluids for cleaning parts.

(l) Properly ventilate work area.

(m) Handle LP gas cylinders with care. Physical damage, such as dents, scrapes, or gauges, may dangerously weaken the tank and make it unsafe for use.

(n) Brakes, steering mechanisms, control mechanisms, warning devices, lights, governors, guards, and safety devices shall be inspected regularly and maintained in a safe operating condition.

(o) Special Personnel and Burden Carriers or devices designed and approved for hazardous area operation shall be inspected to ensure that maintenance preserves the original approved safe operating features.

(p) Fuel systems shall be checked for leaks and condition of parts. Action shall be taken to prevent the use of the carrier until the leak has been corrected.

MAINTENANCE PRACTICES
ANSI B56.8-1981

602 MAINTENANCE PRECEDURES continued

(q) The Personnel and Burden Carrier manufacturer's capacity, operation and maintenance instruction plates, tags, or decals shall be maintained in legible condition.

(r) Batteries, motors, controllers, limit switches, protective devices, electrical conductors, and connections shall be inspected and maintained in conformance with good practice.

(s) Carriers shall be kept in a clean condition to minimize fire hazards and facilitate detection of loose or defective parts.

(t) Modifications and additions which affect capacity and safe machine operation shall not be performed by the customer or user without manufacturer's prior written authorization; where authorized modifications have been made, the user shall ensure that capacity, operation, warning and maintenance instruction plates, tags, or decals are changed accordingly.

(u) Care shall be taken to assure that all replacement parts are interchangeable with the original parts and of a quality at least equal to that provided in the original equipment.

MAINTENANCE GUIDE CHECKLIST

This checklist is provided for your convenience as a guide for servicing your vehicle. If followed you will enjoy a good running and trouble free unit. It has been set up for average normal use. More frequent service is recommended for extreme or heavy usage. If desired your Taylor-Dunn dealer will gladly perform these services for you as he has expert service men in the field for this purpose. Do not hesitate to call your Service Manager if any questions arise.

CAUTION:

When performing maintenance on any part of the electrical system, turn key to off position and remove from switch, disconnect main battery leads and place Forward/Reverse switch in neutral.

MAINTENANCE	REFER SECTION	EVERY WEEK	EVERY MONTH	EVERY 3 MONTHS	EVERY YEAR
Check and fill batteries. If necessary fill with distilled water only.	7	X	X	X	X
Check tire pressure.	10	X	X	X	X
Adjust Motor Mount & Chain (Refer to chart Section 11).	11		X	X	X
Lubricate all Zerk Fittings.	5			X	X
Lubricate all moving parts without Zerk Fittings. Use all purpose engine oil.	5			X	X
Wash off batteries with water (Use soda if necessary).	7			X	X
Check all wire connections. Be sure they are all clean and tight.	13,14			X	X
Check deadman seat and foot operated brake system.	12		X	X	X
Check hydraulic brake system for leaks also check brake fluid level in master cylinder.	12			X	X
Check rear axle differential oil level (Refer to lubrication diagram).	5,11				X

MAINTENANCE GUIDE CHECKLIST

MAINTENANCE SERVICE	REFER SECTION	EVERY WEEK	EVERY MONTH	EVERY 3 MONTHS	EVERY YEAR
* Check brake system, adjust as necessary	11		X	X	X
Check drive axle oil level (Refer to lubrication diagram)	4				X
* Lubricate front wheel bearings (2 zerk fittings)	5				X
* Check brake lining for wear	11			X	X
Drain differential and refill with SAE 30 oil (refer to lubrication diagram)	5 & 11				
Repack front wheel bearings (Use wheel bearing grease)	5 & 10				X
Lubricate steering gear box with 90# grease	5				X
* Check and adjust front wheel bearings	10			X	X
* Items related to safety recommendations					

A. PRESSURE	NO. OF PLACES	FREQUENCY
GUN GREASE	4	3 Months
1. Ball Joints	2	3 Months
2. Front Wheel Hub	2	3 Months
3. Steering Gear Box	1	1 year
Fill to Grease Level Hole. *90 gear tube		
4 BRAKE FLUID DOT #5 SILICONE Master Cylinder		1 year

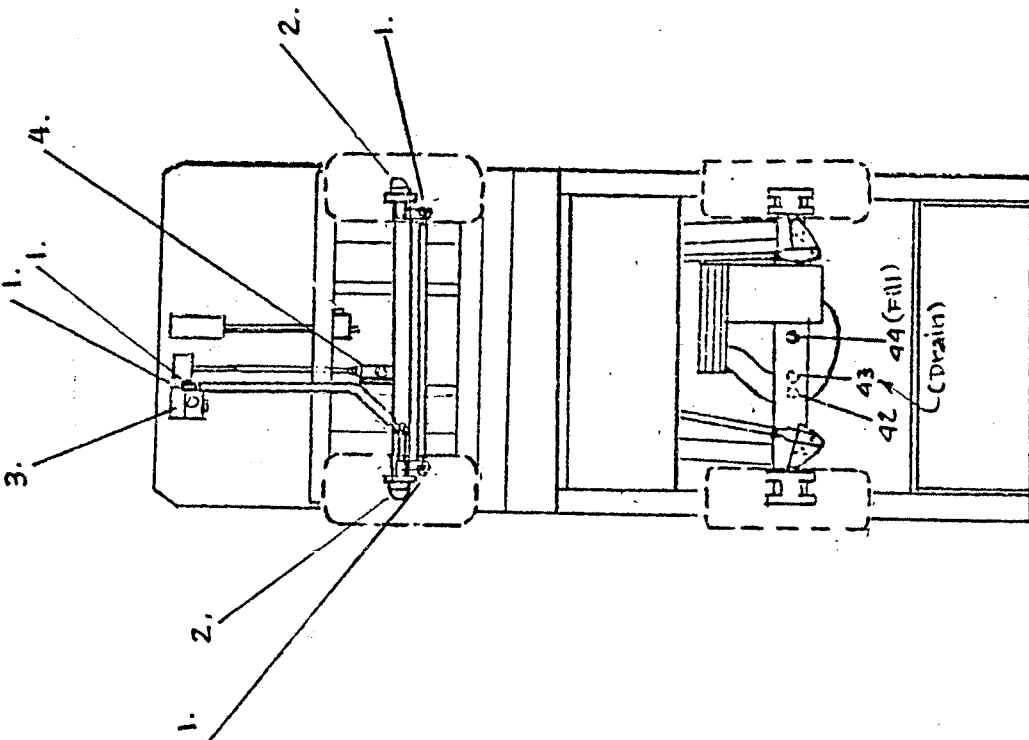
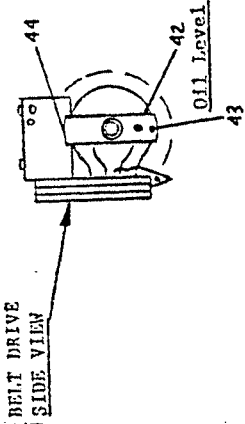
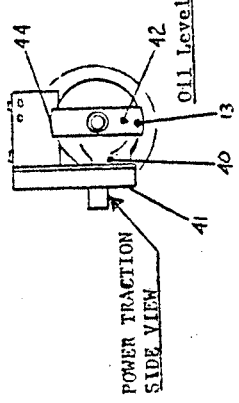

- C. SAE 30 OIL-AXLE & DIFFERENTIAL
- ** 42. Level Check 1 (See Below)
 - *** Change Oil - Power Traction 3 year
 - a. Remove Drain Plugs 41 & 43, Level Plugs 40 and 42, Fill Plug 44.
 - b. Drain Oil, Replace 41 & 43.
 - c. Add Oil by 44 to level of 42.
 - d. Add oil by 40 to 1/2" below 40.
 - e. Replace 40, 42, 44
13. Collar (Grind) No Grease Points
- *** Change Oil - Belt Drive 3 year
 - a. Remove Drain Plug 43, Level Plug 42 and fill Plug 44
 - b. Drain oil, replace 43
 - c. Add oil by 44 to level of 42
 - d. Replace 44

** Check level whenever oil leakage is evident.

*** Or after service work performed

* Items related to safety recommendations.

E. POWDERED GRAPHITE

Key Lock 1 year

LUBRICATION DIAGRAM MODEL 1210B

DO NOT SCALE	TOL: FRAC±	DEC±	ANG±
LUBRICATION DIAGRAM B 2-10			
Taylor-Dunn 2114 WEST BALL ROAD ANAHEIM, CALIFORNIA 92803		SCALE: NONE DWN BY: JPB CHKD BY:	
SECTION 5 PAGE 1		FIG. I SEC. 5 SHEET 1 OF 1	

TROUBLE SHOOTING PROCEDURES

<u>SYMPTOM</u>	<u>PROBABLE CAUSE</u>	<u>CORRECTIVE ACTION</u>
1. <u>Steering:</u>		
a) Hard steering	1. Low tire pressure	Inflate to recommended pressure
b) Sloppy or loose steering	2. Loose wheel bearing	Adjust
2. <u>Brakes:</u>		
a) Soft brakes	1. Check for worn lining	Adjust or replace when 1/16 or less of lining left
	2. Alignment of brake shoes	Realign
	3. Oil on brake lining	Find oil source and correct, wash brake band
	4. Dirt on brake lining	Clean
	5. Bind in linkage	Loosen or realign
	6. Weak spring	Replace
	7. Air in hydraulic brake	Bleed brakes
	8. Bad seals in brake	Replace
b) No Brakes	1. Broken shoe	Replace
	2. Broken Connection in linkage	Replace
	3. Broken axle	Replace
	4. Break in hydraulic line	Repair
	5. Seal failure in brake cylinder	Replace
3. <u>Drive axle</u>		
a) No power	1. Disconnect batteries for recharging	Recharge or replace
	2. Check motor brushes for contact	Clean or replace
	3. Check for loose wire	Tighten or replace
	4. Check continuity through motor	Repair or replace

TROUBLE SHOOTING PROCEDURES continued

<u>SYMPTOM</u>	<u>PROBABLE CAUSE</u>	<u>CORRECTIVE ACTION</u>
<u>3. Drive axle (con't)</u>		
b) Lack of power or slow operation	1. Dragging brake 2. Tight front wheel bearing 3. Loose connection in wiring 4. Partially burned out motor or thrown lead 5. Weak batteries 6. Bind or drag on differential	Re-adjust Re-adjust Tighten Replace or re-solder Replace Repair
c) Thump or grinding	1. Motor bearing 2. Loose motor on base 3. Worn sprockets 4. Defective bearing in differential 5. Defective gears in differential 6. Slack drive chain	Replace Tighten & adjust Replace sprocket and chain Replace Replace Adjust

IMPORTANT FACTS ON BATTERIES AND CHARGERS

To determine whether or not a battery is properly charged, a measuring device known as a hydrometer is used. A hydrometer measures the specific gravity of a liquid and a battery hydrometer is graduated to measure the specific gravity of battery electrolyte. The electrolyte in your battery becomes heavier as it is charged, therefore, a higher specific gravity reading indicates a higher charge condition of your battery. The specific gravity reading will range from 1100 for a completely discharged battery to 1260 for a fully charged battery. No amount of overcharging will raise the specific gravity above 1260 on the electric vehicle type of battery. Both overcharging and undercharging can cause a premature failure of a battery. Overcharging destroys the positive plates. Consistent undercharging causes a buckling of the plates.

Do not discard a good battery as being defective because its specific gravity does not show an increase immediately upon applying a charge. Many good batteries require a charging period as long as three hours before they show any increase in the specific gravity. Do not charge a battery if the electrolyte temperature could rise above 120 degrees F. This could damage both battery and charger. As a rule of thumb, the electrolyte temperature during normal charging will rise about 25 degrees above the temperature in the charging area.

Failure to keep the battery electrolyte to the proper level will result in a crumbling (abnormal sulfation) of the plates and cause failure of the battery. Distilled water must be added to the battery regularly to make up for the loss due to evaporation. Prior to charging, the electrolyte level should cover the battery plates. Fill the battery to the proper level only after it has been fully charged.

BATTERIES, INSPECTION

WARNING - HAZARD OF EXPLOSIVE GAS MIXTURE

Batteries being charged or discharged will give off hydrogen gas. If this gas is concentrated it can cause an explosion. Concentrations of gas may remain for several hours if ventilation is not provided. DO NOT have any fire in the vicinity and do not tamper with circuits that might cause sparking while charging or discharging batteries.

INSPECTION OF BATTERIES AND ASSOCIATED CIRCUITS

An inspection of batteries and associated circuits is required to assure that the batteries are being properly charged. For this inspection we recommend the use of a hydrometer and a continuity tester.

1. Verify that all connections within the unit to be charged are clean and right.
2. Check each battery for loose terminal posts.
3. Test for continuity between all battery terminals and the charging receptacle.
4. Verify that the top of each battery is free of moisture, grease and acid film, which may cause terminal corrosion and current leakage.
5. After the battery has been recharged, test each individual cell in each battery with the hydrometer to verify that all specific gravity readings are within 10 points of each other.
6. Using the hydrometer, pull out acid from a cell and then vigorously expel the acid back into the cell to cause a violent stirring action. Immediately draw out another sample of acid and visually inspect it to see if it contains a brownish sediment (indicates positive plates are deteriorated).
7. When testing battery condition with hydrometer, always return electrolyte solution to the same cell from which it was removed. DO NOT MIX electrolyte from one cell to another.

MAINTENANCE PROCEDURES BATTERIES

WARNING: Lead acid batteries continuously emit highly explosive gases. Flame or sparks must be kept away from the batteries at all times.

This emission is greatly increased during the charging process. Any area in which charging batteries are confined must be well ventilated, and flame or sparks must be kept out of the charging area and away from ventilator openings. DO NOT disturb battery connections while batteries are being charged.

The lead acid battery (or batteries) will furnish all power required by your vehicle. Two types are generally employed. The electric vehicle type battery pack, commonly used, can be expected to have a life of approximately 2 years, or 350 to 400 cycles. One cycle is the discharging and charging of the battery within proper limits. The heavy duty industrial type of battery has a life of approximately 7-1/2 years, or 1800 cycles, with appropriate use and care.

It cannot be over emphasized how important good maintenance procedures and careful care of your batteries will affect their useful life. It is therefore recommended that a comprehensive maintenance program be established and adhered to throughout the life of your vehicle. A 5 point program is outlined below to assist you in understanding and establishing good battery care.

1. CORRECT CHARGING

Poor charging practices are responsible for more short battery life than any one other item. The charging equipment must be properly maintained and adjusted to give a charge which the battery will accept with maximum efficiency. Two things are involved in correct charging. These are the charging rate in amperes and the termination of the charge at the correct time. No amount of overcharging will increase the battery capacity or raise the specific gravity above its full charged condition.

Overcharging will reduce battery life. Undercharging will cause poor vehicle performance, and shorten the life of all electrical components, including the batteries. Refer to Section 8 for proper methods to determine charge condition.

2. DISCHARGING - CAPACITY

Batteries are commonly rated in ampere hours at the six hour discharge rate to final voltage of 1.75 per cell. They will deliver additional capacity in an emergency, but should not be required to do so regularly. The best way to avoid discharging is to prepare a rigid schedule for charging batteries which will insure against their being discharged beyond the limits of their capability.

MAINTENANCE PROCEDURES, BATTERIES, continued

3. WATERING

Water must be replaced from time to time. The frequency and quantity depends upon the watering space above the plates and the amount of gassing which the battery does on charge. Only approved or distilled water should be added to the battery. Water should be added after hydrometer or voltmeter readings have been taken. The liquid level within the battery raises as the gassing occurs. Thus filling after charging minimizes over-filling. However, the water level should cover the plates prior to charging.

4. CLEANING

Batteries pick up various kinds of dirt and dust, depending on their surroundings and the type of service they are subject to. This is usually dry dirt, which can be blown off with low pressure air or brushed off. However, if cells are overfilled and electrolyte collects on the covers, the top of the battery becomes wet and stays wet, since the acid in the electrolyte does not evaporate. This moist surface in combination with certain kinds of dirt becomes electrically conductive and permits stray currents to flow externally over the top of the battery. These currents cause corrosion of cell posts, nuts, connectors and steel trays, which eventually become troublesome and expensive to repair.

When wet dirt accumulates on top of the battery, remove it by washing the battery with a strong solution of baking soda and hot water (1 lb. soda to 1/2 gallon of water). A convenient brush to use is one having flexible bristles like an old paint brush. Continue the application of the soda solution until all fizzing stops, which indicates that the acid has been neutralized. Then rinse thoroughly with clear water.

Wet covers can be indication of overfilling, leaky seals at posts and covers or of excessive gassing during charge. When observed the cause should be determined and the abusive conditions corrected.

5. RECORDS

A battery record system is recommended for all vehicles. It is considered essential for large operations, and where minimum battery operating cost is desired. A properly supervised record system can be made to detect and call attention to such operating irregularities as:

- a. Overcharging,
- b. Undercharging,
- c. Overdischarging,
- d. Excessive Water Consumption,
- e. Cleanliness,
- f. Worn Out Batteries,
- g. Excessive Current Consumption on Trucks

It is not advisable to allow a battery to stand for a long period of time in a low state of charge. Doing so subjects the battery to excessive plate erosion and in cold conditions the electrolyte will freeze at a much higher temperature. For example, a fully charged battery will not freeze at temperatures near 60 degrees below zero. Yet a battery in a very low state of charge may freeze at temperatures around 10 to 15 degrees above zero.

A battery not in use maintains small amounts of chemical action which slowly tends to dissipate the charged condition. It is wise to re-charge a battery not in use every 1 to 2 months. If possible, store the battery in a cool place as the self discharge rate is increased with warmer temperatures.

BATTERIES AND CHARGER

T-D PART NO.	DESCRIPTION	QTY. REQ.
74-009-00	Charger Indicator (36 Volt)	1
75-235-08	Battery Jumper #6 Wire (10-1/4 In. Long)	5
76-003-00	Charging Plug, 2 Prong (Optional)	1
76-013-00	Charging Receptacle, 2 Prong (Optional)	1
77-031-00	6 Volt, 190 A.H. Battery	6
77-042-00	6 Volt, 217 A.H. Battery	6
77-047-00	6 Volt, 244 A.H. Battery	6
77-048-00	6 Volt, 250 A.H. Battery	6
77-200-00	Hydrometer	1
77-201-00	Battery Filler	1
50-243-10	Hold-down	2
50-250-00	Battery, BAT-LOK	2
79-304-05	Charger, 36 Volt, 25 AMP Line Comp. 115 V/60 HZ, BI	1

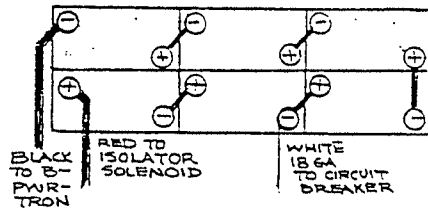

ALL WIRE 4 GA. UNLESS NOTED
B2-10 TYPICAL BATTERY WIRING

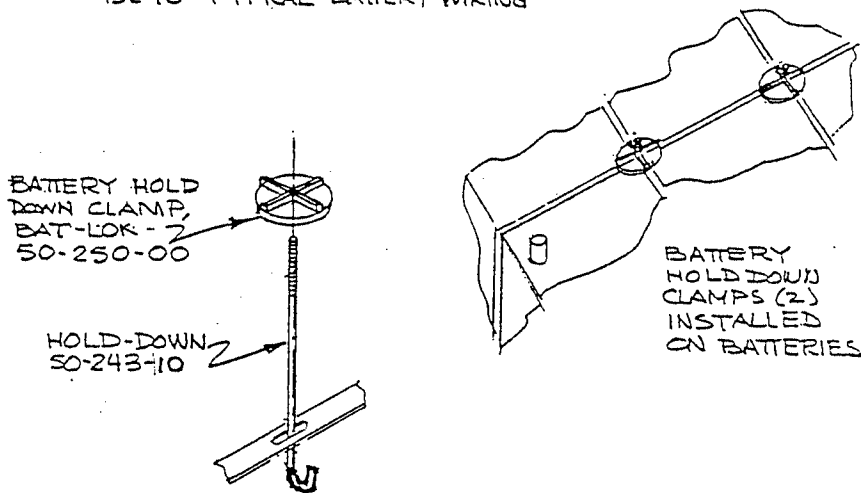

INSTALLATION OF BATTERY HOLD DOWN ROD & CLAMP

B 2-10 BATTERY INSTALLATION

CHARGER MAINTENANCE, SERVICE AND ADJUSTMENT

TAYLOR-DUNN / LESTER-MATIC
BATTERY CHARGER

Line voltage compensation achieved by flux oscillator circuit applied to battery chargers by Lester in 1962 for high reliability "Minute Man" missile standby applications. Compensates automatically for AC supply voltage variations 105-128 volts. Supply voltage variation $\pm 10\%$ from 117 volts = $\pm 1\%$ maximum battery voltage variation, decreasing to $\pm 1/2\%$ at finish rate with constant electrolyte temperature. No taps or rate controls to set.

Automatic taper of charge rate for superior battery life through good equalization of cells and low water use rate.

Silicon diodes with inherent surge protection operated at a conservative percentage of their rating.

Convection cooled design for maximum reliability and minimum maintenance.

LESTRONIC II BATTERY CHARGERS

The all new automatic Lestronic chargers eliminate over and undercharging for new, old or defective batteries, whether hot or cold. Precise charging is achieved by patented Electronic Timer, utilizing state of the art integrated circuits.

Charger turns on automatically by simply connecting D.C. cord to batteries. The ammeter indicates charge rate. The charge rate tapers gradually to a finish rate of 5 to 10 amps. The Electronic Timer monitors the rate of voltage change during the charge period. When this rate levels off, the charger automatically shuts off.

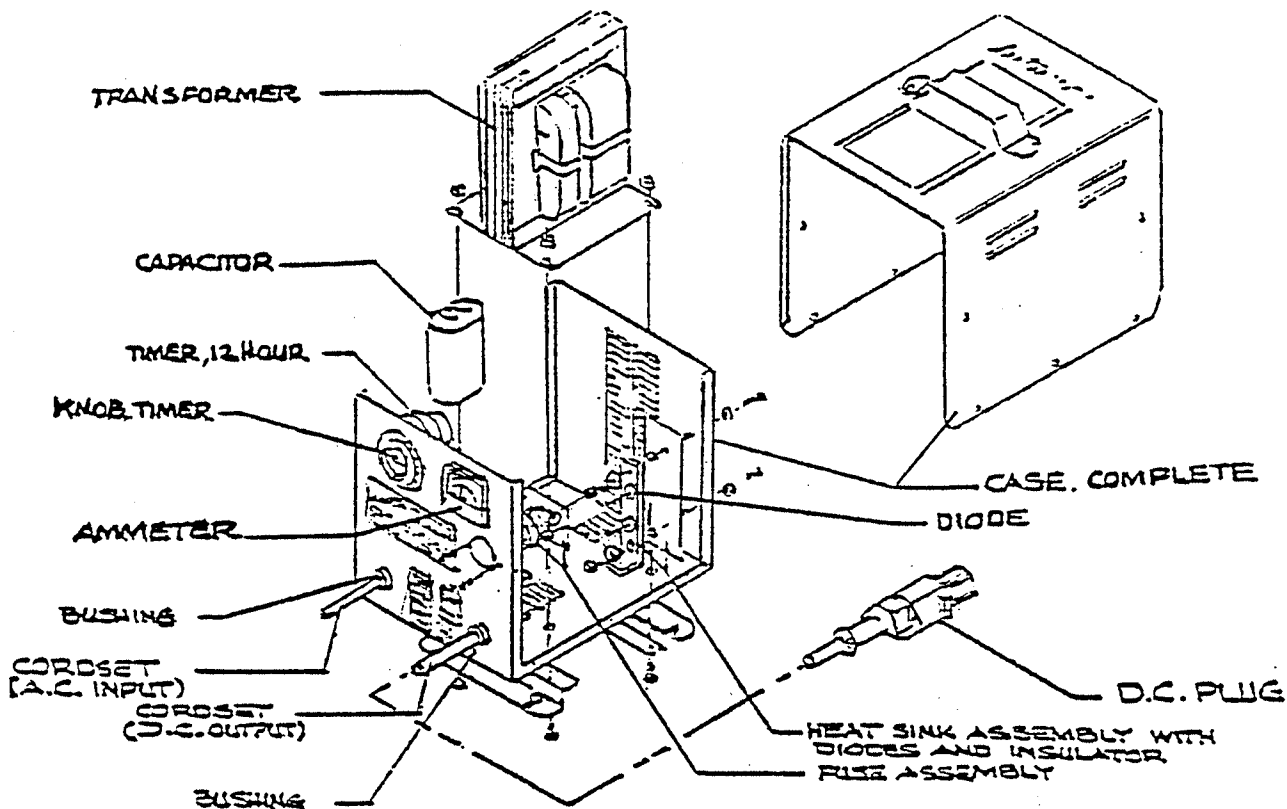

PORTABLE LESTER CHARGER
(TYPICAL) FOR COMPONENT IDENTIFICATION
SEE PARTS LIST FOR PORTABLE CHARGERS

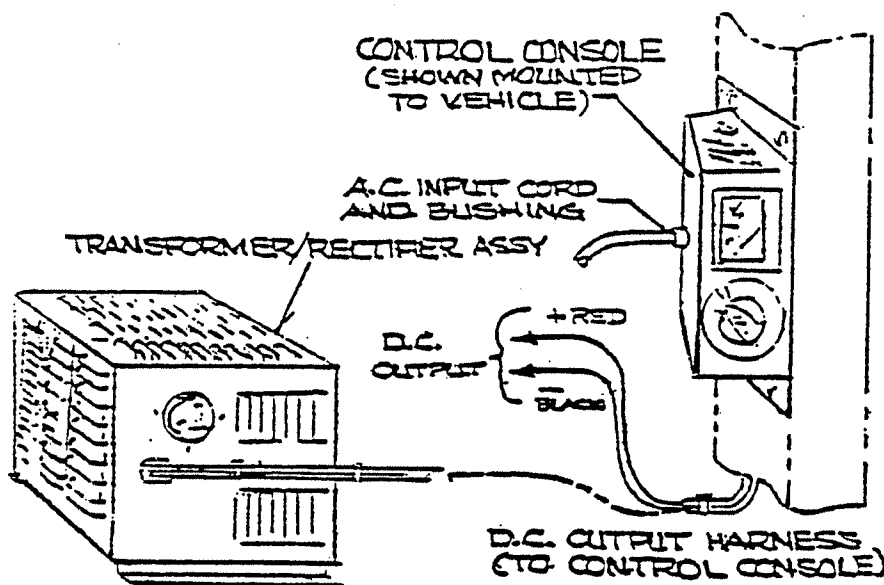

NOTE: CONTROL CONSOLE CONSISTS OF: A.C. CORD AND BUSHING, AMMETER, 12-HOUR TIMER AND TIMER KNOB

THE TRANSFORMER RECTIFIER ASSY CONSISTS OF: RISE ASSY, HEAT SINK ASSY WITH DIODES AND INSULATOR, D.C. HARNESS AND BUSHING, CAPACITOR AND TRANSFORMER

NOTE: HAS SAME BASIC PARTS AS PORTABLE.

BUILT-IN LESTER CHARGER
(TYPICAL) FOR COMPONENT IDENTIFICATION
SEE PARTS LIST FOR BUILT-IN CHARGERS

OPERATION OF "LESTER MATIC" BATTERY CHARGERS

INTRODUCTION

The Lester-Matic battery charger is a highly reliable, line compensating unit. When used according to instructions, the Lester-Matic will tend to lengthen battery life with less frequent additions of water.

INITIAL INSTALLATION:

Circuit breaker or fuse protection in the AC line to which the charger is to be plugged should allow at least 15 amps per charger. When it is necessary to use an AC extension cord to the charger, use a three conductor No. 12 AWG cord with ground, and keep as short as possible. Instructions printed on the cover of the charger are for daily reference.

NORMAL OPERATION

The state of discharge of the batteries will be slightly different every time they are put on charge, but the Lester-Matic varies automatically the initial charge rates, and taper of charge rate over the charge period. Thus momentary initial charge rate will vary from 18-30 amps, dropping quickly to a lower value, and then tapering gradually over the charge period to a finish rate of 1-4 amps (in the green shaded area of the ammeter dial) for the last 1-3 hours. When batteries are slightly discharged, the ammeter needle will be in the green shaded area for 7-8 hours, but the specific gravity will not rise to full charge until the cells have been equalized. The normal charging with the ammeter needle in the green shaded area is important to achieve equalization of all battery cells, every time the batteries are charged. Since the taper of the charging rate (in amps, as indicated by the ammeter needle) is controlled by the rising voltage of the batteries being charged, proper performance of the charger and resulting good battery life is dependent upon the following factors:

1. An adequate AC line to handle the power required (see "Initial Installation").
2. All cells of the batteries must be good, rising to approximately 2.5 DC volts per cell while still on charge or near the end of a 12-hour charging period. When in doubt, check each cell with a single voltmeter while still on charge. If a low reading is obtained; check the low cells with a temperature corrected hydrometer. NOTE: Hydrometer float must be thoroughly clean to obtain accurate specific readings.

OPERATION OF "LESTER-MATIC" BATTERY CHARGERS continued

3. All electrical connections of the vehicle must be clean and tight.
4. Batteries should be charged just enough to bring them to full charge because overcharging is harmful. The state of charge can be tested accurately in each cell with a hydrometer or cell tester (voltmeter), but to simplify maintaining a fleet of cars, which normally require charging at least once a day, the following "CHARGING TIME CHARTS" can be used for daily charging. Set timer knob to desired charging time shown in chart. Charger shuts off automatically at end of set period.

CHARGING TIME CHART

GOLF CAR USE	CHARGING TIME
9 Holes or Less	7 Hours
18 Holes or More	12 Hours
COMMERCIAL USE	
Less than 1 Hour	7 Hours
More than 1 Hour	12 Hours

If a golf car is used only occasionally, it is recommended that a several refresher charge be given prior to using the car.

Commercial cars, not used in golf course operation, should be charged after use each day, or as charge becomes low as indicated by hydrometer or voltmeter test.

The necessity of adding water more frequently than two or three weeks, and/or hot battery cases at the end of the charging cycle, indicates the finish rate is too high, due to one or both of the following:

1. One or more bad cells in the batteries.
2. Batteries are starting to age to a point where hours of charge should be reduced gradually to obtain prolonged battery life.

STORAGE

Charger may be left connected to the batteries and should be turned on for the 12-hour period once a month. In extremely cold conditions it may be necessary to charge more frequently. Check with your battery manufacturer. After each charge cycle the charger should be checked to ensure

OPERATION OF "LESTER-MATIC" BATTERY CHARGERS continued

STORAGE continued

that it has turned off. Severe overcharging and possible damage to the batteries could result if the charger remains on for prolonged periods of time.

CAUTION

THIS CHARGER IS FOR USE ONLY ON BATTERY SYSTEMS OF THE TYPE AND CAPACITY SPECIFIED ON THE CHARGER NAMEPLATE. USE OTHERWISE WILL DAMAGE CHARGER AND/OR BATTERIES.

Due to the electrical characteristics of this charger, it is possible to improperly hook up batteries and not blow the fuses when charging. When installing batteries, be sure polarity is correct. With a DC voltmeter, check terminal voltage and polarity at the car receptacle.

CAUTION

When working near capacitor terminals be sure charger is turned off. With charger "on" transformer capacitor voltage is approximately 640 volts. Use care. Before performing service, disconnect AC and DC leads. Discharge capacitor before servicing.

STEP BY STEP OPERATING PROCEDURES

1. Provide adequate ventilation for both batteries and charger. The convection-cooled Lester-Matic requires an unobstructed flow of cooling air for proper operation.
2. Connect DC plug (portable unit) to vehicle receptacle.
3. Turn timer to "ON" for well discharged batteries or to 7" for lightly discharged batteries. Charger shuts off automatically at end of set period.
4. To determine approximate full charge at start of days use, turn timer knob to 1". Drop of ammeter needle to 1-4 amps in 15 minutes or less indicates full charge.
5. ALWAYS TURN TIMER TO "OFF" BEFORE DISCONNECTING CHARGER FROM BATTERIES.

POWER CARE OF MOTIVE POWER BATTERIES

NEW BATTERIES

1. Brand new batteries should be given a 12 hour charge before their first use, because it is difficult to know how long vehicle batteries have been in storage without a charge since new.
2. Limit use of brand new batteries between charges for first 5 cycles. New batteries and older batteries which have been in storage are not capable of their rated output until they have been discharged and charged a number of times.
3. During the first month of new batteries, particularly when night-time temperatures are below 60 F, give them an extra 12 hour charge once a week. The ampere-hours of energy that batteries can deliver and their charge acceptance varies directly with battery temperature.
4. All batteries that still taper down into the 1-4 amps area of the ammeter toward end of charge should be given the full 12 hours of charge. All cells in a set of batteries do not react identically to the same discharge and charge current. In a normal 12 hours charge the last 3 to 5 hours at low finish charge rate equalize the cells for better battery life.
5. When batteries age to the point where charge rate no longer tapers into the 1-4 amps area of the ammeter, reduce the hours of charge progressively to 10 hours, 8 hours, and finally down to 6 hours near the end of useful life. As batteries age, their on-charge voltage at end of charge period drops progressively, thereby causing a high finish charge rate in amperes and resultant higher water use rates.

VERIFY BATTERIES ARE CHARGED

1. Turn on the time first thing in the morning and check to see if charger ammeter needle jumps smartly to 15 amps or more and then tapers into the 1-4 amps area within 15 minutes. This will provide a very simple means of verifying that the batteries were truly charged the night before. It also shows aging batteries whose finish charge rate will not taper into the ammeter 1-4 amps area.
2. Add water carefully to proper level in cells as required after they have been fully charged. Do not fill them so high that they bubble over while charging. New batteries require very little additional water, whereas very old batteries may need additional water two or three times a week. Water

PROPER CARE OF MOTIVE POWER BATTERIES continued

VERIFY BATTERIES ARE CHARGED continued

(electrolyte) level in battery cells settles when batteries are discharged and rises during charge. The probability of overfilling can be reduced by adding water when batteries are fully charged.

PREVENTIVE MAINTENANCE

1. When night air temperatures fall below 65 degrees F, batteries charged in unheated areas should be placed on charge as soon after use as possible. Under such condition a 4 hour equalize charge once a week in the early afternoon will improve state of charge and battery life.
2. Keep tops of batteries and battery hold-downs clean and dry. Tops of batteries and battery hold-downs must be kept clean at all times to prevent voltage leakage and flow of current between the batteries and the vehicle frame.

WARNING

LEAD ACID BATTERIES CONTINUOUSLY EMIT HIGHLY EXPLOSIVE GASES. DURING NORMAL VEHICLE OPERATION THE CONCENTRATION OF THESE GASES IS A POTENTIAL HAZARD TO BE CONSIDERED DANGEROUS WHEN FLAME OR SPARKS OCCUR IN THE BATTERY COMPARTMENT CLOSE TO THE VENT HOLES IN THE BATTERY CAPS. IT IS IMPORTANT THAT THIS NOT BE ALLOWED TO OCCUR AT ANY TIME. LIGHTED CIGARETTES MUST NOT BE BROUGHT CLOSE TO THE BATTERY COMPARTMENT.

DURING THE CHARGING PROCESS, EMISSIONS ARE GREATLY INCREASED.

ANY AREA IN WHICH CHARGING BATTERIES ARE CONFINED MUST BE WELL VENTILATED, AND FLAME, SPARKS, OR LIGHTED CIGARETTES MUST BE KEPT OUT OF THE CHARGING AREA AND AWAY FROM VENTILATOR OPENINGS ASSOCIATED WITH THE CHARGING AREA. BATTERY CONNECTIONS MUST NOT BE DISTURBED WHILE BATTERIES ARE BEING CHARGED.

NOTE: Please refer to your Taylor-Dunn vehicle maintenance manual for a more detailed description on battery maintenance.

MALFUNCTIONS SYMPTOMS AND THEIR REMEDIES

1. The Lester-Matic charger is designed with as few parts as possible. Since each component can be tested individually, trouble shooting is a simple task. The following is a list of symptoms with their associated test procedures and remedies.

MALFUNCTION SYMPTOMS AND THEIR REMEDIES continued

NO TRANSFER HUM AND AMMETER DOES NOT REGISTER

In the event no hum is detected from the transformer, check the AC cord to be sure it is securely plugged into a live AC outlet. When three-prong to two-prong adapters are used, they tend to work loose giving a poor connection. If the cord connection is secure and still no hum is noticed, a continuity test of the AC circuit is necessary. Turn the timer to "ON" and, with a suitable continuity tester, check circuit across the AC plug prongs (Figure 1). CIRCUIT SHOULD BE COMPLETE. If not complete, individually check the AC cord, timer, primary transformer coil, and all connections.

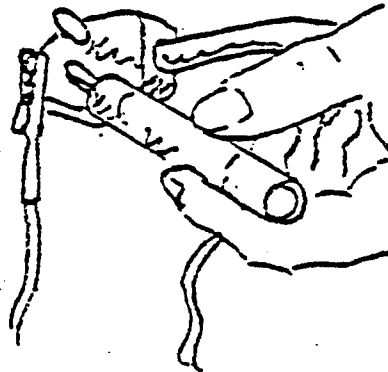

FIGURE 1

TRANSFORMER HUMS BUT NO AMMETER INDICATION

Inspect the DC plug connection to the vehicle receptacle and also check to ensure that the batteries are connected properly to the receptacle. If there is still no ammeter indication, a continuity test of the charger DC circuit must be performed. Turn the timer to "OFF" and disconnect the AC and *DC plugs. Perform the following tests, using a low voltage tester, to check the continuity of the DC circuit.

* For built-ins, disconnect AC plug and DC leads to battery to isolate charger.

(a) Connect tester clip to negative (-) blade and probe to positive (+) blade (Figure 2). CIRCUIT SHOULD BE COMPLETE. If not complete, first check the DC fuse link.

MALFUNCTION SYMPTOMS AND THEIR REMEDIES continued

TRANSFORMER HUMS BUT NO AMMETER INDICATION continued

If one or both fuses have blown, the link will be broken and usually the clear plastic fuse cover will be discolored. Refer to "Fuse Link Blowing" for test procedures. If fuses are good, individually check the fuse connections, DC cord, and diode connections (each may be checked with the continuity test light).

NOTE: On built-in charger the lead is (+) and black lead is (-) on DC output.

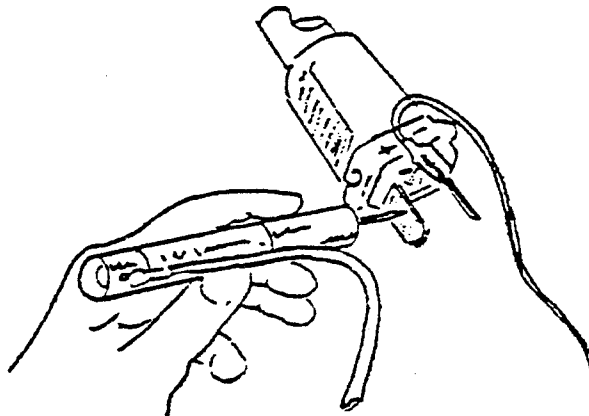

Typical plug.
Check same
polarity on
other plugs.

FIGURE 2
D.C. PLUG CHECK FOR PORTABLE CHARGERS ONLY

- (b) If the circuit in Figure 2 is complete, reverse test tight leads as shown in Figure 3. CIRCUIT SHOULD NOT BE COMPLETE. If circuit is complete, check DC cord for a "short" between the two wires. More probably, one or both diodes have "shorted". Refer to "Fuse Link Blowing" part (b) for continuity test of diodes.

MALFUNCTION SYMPTOMS AND THEIR REMEDIES continued

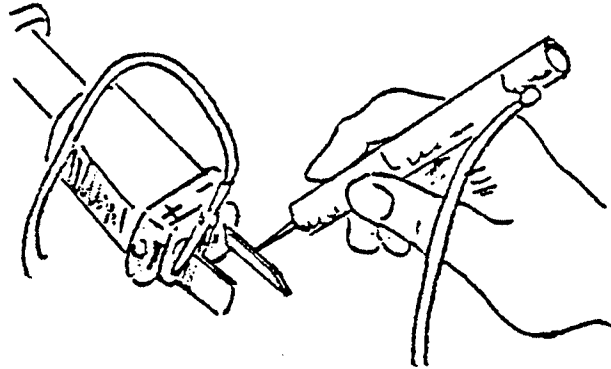

FIGURE 3
D.C. PLUG CHECK FOR PORTABLE CHARGERS ONLY

CAUTION: Discharge capacitor before proceeding with (c).

- (c) If (a) Figure 2 and (b) Figure 3 check good, assume the capacitor is shorted. Remove one wire from a capacitor terminal and place continuity tester clip to one terminal and probe to other. If circuit is complete, capacitor is "shorted" and must be replaced.

CHARGER DC FUSE LINK(S) BLOWS

This condition is caused by:

- (a) Reverse polarity between charger and batteries, such as incorrect installation of batteries, wiring of DC receptacle or charger plug.
- (b) A short circuit failure of one or both diodes. First disconnect one diode. Using a low voltage continuity tester check each diode as shown in Figure 4. Then reverse the tester leads and check each diode again. If the diode conducts current in both directions the diode is shorted and must be replaced. Replace either the entire heat-sink assembly or the defective diode. When replacing a single diode be sure the new diode is pressed squarely into the hole and does not extend beyond the rear surface of the heat-sink plate.

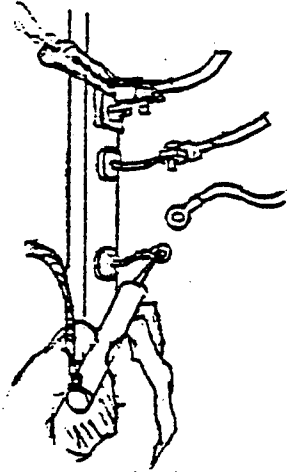

FIGURE 4

(c) If (a) and (b) fail to reveal the malfunction, check wiring of both charger and vehicle against their respective wiring diagrams.

CHARGER OUTPUT IS LOW

The most probable cause is one diode shorting and blowing one fuse. Refer to "Fuse Link Blowing" part (b) to check the diodes. If a diode is shorted both the heat sink and fuse assemblies must be replaced.

CHARGER DOES NOT TURN OFF

In models equipped with timers, this is due to an inoperative timer. In this case replace timer assembly.

AC LINE FUSE OR CIRCUIT BREAKER BLOWS

If this occurs when charger is turned on without being plugged into the vehicle, the AC cord, timer motor coil, or the transformer may be shorted. To check the AC cord, ensure that the time of "OFF" and connect the continuity tester across the AC plug prongs. If circuit is complete the AC cord is shorted and must be replaced. To check the time motor coil, disconnect the white timer motor wire and connect continuity tester to the motor coil leads. If the lamp glows, the coil is shorted. To test the transformer, disconnect secondary leads #1 and #4. If the AC fuse or breaker still blows, the transformer is shorted internally and must be replaced.

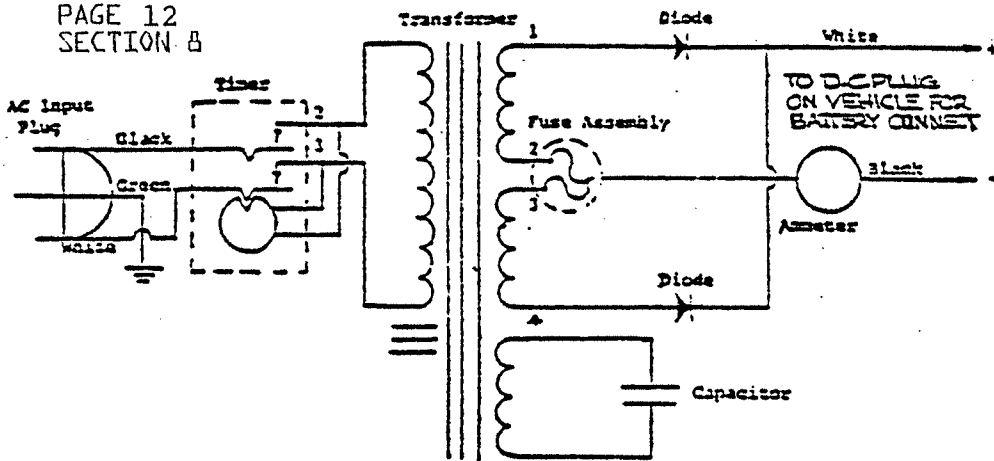

A. TYPICAL PORTABLE CHARGER

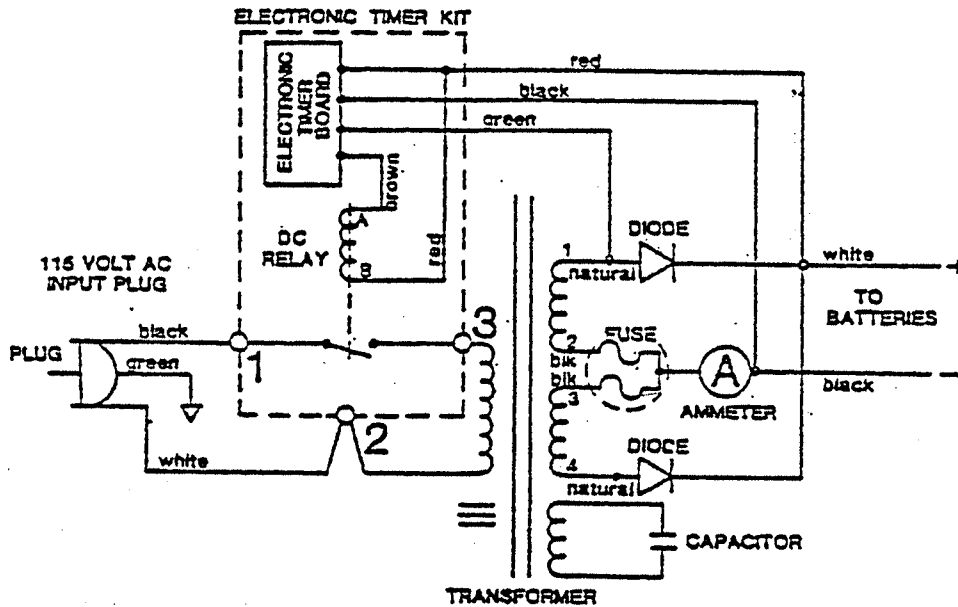

B. TYPICAL PORTABLE ELECTRONIC TIMER CHARGER (LESTRONICII)

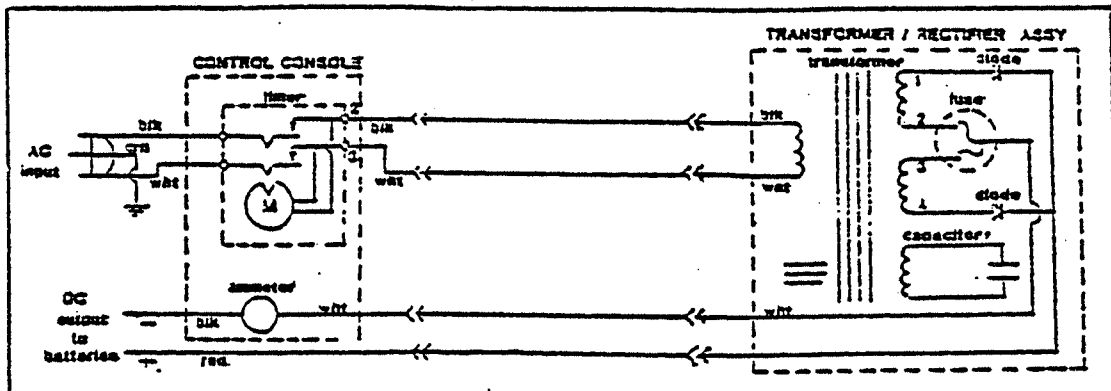
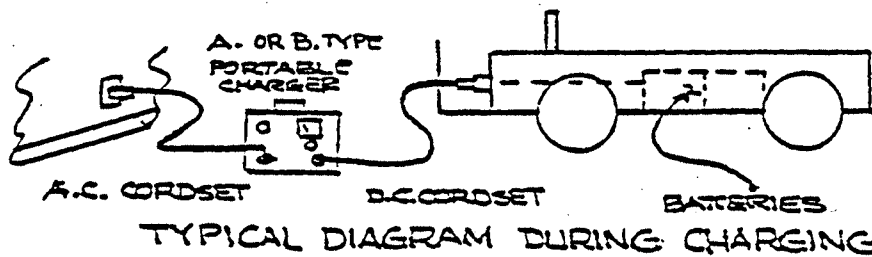

SCHEMATIC, LESTER CHARGER
TYPICAL FOR ALL BUILT-IN CHARGERS

PARTS LIST, BUILT-INS
RECOMMENDED REPLACEMENT PARTS

Taylor-Dunn Part No.	79-300-95	79-300-05	79-306-95	79-306-05	79-304-95
Lester Model No.	24LC25-3T12 230/50 7670	24LC25-3T12 115/60 7675	36LC40-4T12 230/50 7640	36LC40-4T12 115/60 7650	36LC25-3T 230/50 7655
TRANSFORMER/RECTIFIER ASSEMBLY, COMPLETE					
Transformer	79-644-13	79-644-11	79-644-22	79-644-20	79-644-18
Capacitor	79-902-00	79-902-00	79-902-00	79-902-00	79-902-00
Heat Sink Assy. with diodes	79-749-11	79-749-11	79-749-10	79-749-10	79-749-11
Diode Replacement	79-745-10	79-745-10	79-745-11	79-745-11	79-745-10
Fuse Assembly	79-831-00	79-831-00	79-831-11	79-831-11	79-831-00
CONTROL CONSOLE ASSEMBLY					
Bushing, for Cordsets	79-530-00	79-530-00	79-530-00	79-530-00	79-530-00
Housing	79-599-10	79-599-10	79-599-10	79-599-10	79-599-10
Timer	79-805-11	79-805-00	79-805-11	79-805-00	79-805-11
Knob, Timer	79-806-00	79-806-00	79-806-00	79-806-00	79-806-00
Ammeter	79-851-10	79-851-10	79-852-00	79-852-00	79-851-10
Cordset, A.C.	79-575-20	79-575-10	79-575-20	79-575-10	79-575-20

PARTS LIST, BUILT-INS

RECOMMENDED REPLACEMENT PARTS

Taylor-Dunn Part No.	79-304-05	79-308-95	79-308-05	PORTABLE 79-305-00 *79-305-05	PORTABLE 79-301-00 *79-301-05
Lester Model No.	36LC25-3T12 115/60 7660	48LC40-4T12 230/60 7625	48LC25-3T12 115/60 7635	PORTABLE LESTRONIC II 36LC25-8ET 115/60 *BUILT-IN	PORTABLE LESTRONIC II 24LC25 115/60 *BUILT-IN
TRANSFORMER/RECTIFIER ASSEMBLY					
Transformer	79-644-16	79-644-26	79-644-24	79-644-27	
Capacitor	79-902-00	79-902-00	79-902-00	79-902-00	
Heat Sink Assy. with Diodes	79-749-11	79-749-10	79-749-10	79-749-13	
Diode Replacement	79-745-10	79-745-11	79-745-10	79-749-10	
Fuse Assembly	79-831-00	79-831-11	79-831-00	79-831-00	
CONTROL CONSOLE ASSEMBLY				N/A	N/A
Bushing, for Cordsets	79-530-00	79-530-00	79-530-00	79-530-00	
Housing	79-599-10	79-599-10	79-599-10		
Timer	79-805-00	79-805-10	79-805-00	ELECTRONIC TIMER 79-805-63	79-805-64
Knob, Timer	79-806-00	79-806-00	79-806-00		
Ammeter	79-851-10	79-852-00	79-851-10	79-851-10	
Cordset, A.C.	79-575-10	79-575-20	79-575-10	79-575-10	

PARTS LIST, PORTABLE

RECOMMENDED REPLACEMENT PARTS

Taylor-Dunn Part No.	79-302-90	79-302-00	79-300-00	79-300-90	79-306-90
Lester Model No.	24LC40-4T12 230/50 7665	24LC40-4T12 115/60 8781	24LC25T12 115/60 8824	24LC25T12 230/50 8875	36LC40-4T12 230/50 7645
Case					
Transformer	79-644-15	79-644-14	79-644-10	79-644-12	79-644-21
Capacitor	79-902-00	79-902-00	79-902-00	79-902-10	79-902-00
Ammeter	79-852-00	79-852-00	79-851-10	79-851-10	79-852-00
Timer	79-805-11	79-805-00	79-805-00	79-805-11	79-805-11
Knob, Timer	79-806-00	79-806-00	79-806-00	79-806-00	79-806-00
Heat Sink Assy. with Diodes	79-749-10	79-749-00	79-749-10	79-749-00	79-749-10
Diode Replacement	79-745-11	79-745-10	79-745-10	79-745-10	79-745-11
Fuse Assembly	79-831-10	79-831-10	79-831-00	79-831-00	79-831-10
Cordset, A.C.	79-575-20	79-575-10	79-575-10	79-575-20	79-575-20
Cordset, D.C.	79-567-10	79-567-10	79-566-10	79-566-10	79-567-10
Bushing for Cordsets, A.C.	79-530-00	79-530-00	79-530-00	79-530-00	79-530-00
Bushing for Cordsets, D.C.	79-531-00	79-531-00	79-530-00	79-530-00	79-531-00
Plug, D.C. Replacement	76-003-00	76-003-00	76-003-00	76-003-00	76-003-00

PARTS LIST, PORTABLE

RECOMMENDED REPLACEMENT PARTS

Taylor-Dunn Part No.	79-304-00	79-304-90	79-306-00	79-308-90	79-308-00 *79-309-00
Lester Model No.	36LC25T12 115/60 8714 and * 9611	36LC25T12 230/50 8876	36LC40-4T12 115/60 9080	48LC40-4T12 230/60 7630	48LC25T12 115/60 8882 * LestronicI 9695
Case					
Transformer	*79-644-00 *79-644-28	79-644-17	79-644-19	79-644-25	79-644-23
Capacitor	79-902-00	79-902-10	79-902-00	79-902-00	79-902-00
Ammeter	79-851-10	79-851-10	79-852-00	79-852-00	79-851-1
Timer	79-805-00	79-805-11	79-805-00	79-805-10	79-805-00 *79-805-65
Knob, Timer	79-806-00	79-806-00	79-806-00	79-806-00	79-806-00
Heat Sink Assy. with Diodes	79-749-00 *79-749-13	79-749-00	79-749-10	79-749-10	79-749-00
Diode Replacement	79-745-10	79-745-10	79-745-11	79-745-11	79-745-10
Fuse Assembly	79-831-00	79-831-00	79-831-10	79-831-10	79-831-00
Cordset, A.C.	79-575-10	79-575-20	79-575-10	79-575-20	79-575-10
Cordset, D.C.	79-566-10	79-566-10	79-567-10	79-567-10	79-566-10
Bushing for Cordsets A.C.	79-530-00	79-530-00	79-530-00	79-530-00	79-530-00
Bushing for Cordsets, D.C.	79-530-00	79-530-00	79-531-00	79-531-00	79-530-00
Plug, D.C. Replacement	76-003-00	76-003-00	76-003-00	76-003-00	76-003-00

RECOMMENDED SPARE PARTS

COMPONENTS	SPARES FOR VEHICLES	
	1 - 20	20 or MORE
TRANSFORMERS	1	2
CAPACITORS	1	2
AMMETERS	1	2
TIMERS	1	2
KNOB - TIMER	2	5
HEAT SINK ASSEMBLY	1	2
DIODES	2	4
FUSE ASSEMBLY	2	4
CORDSET A.C.	2	4
CORDSET D.C.	2	4
PLUG D.C.	2	4
HOUSING, CONTROL CONSOLE	2	1
TIMER, BOARD ELECTRONIC	1	2

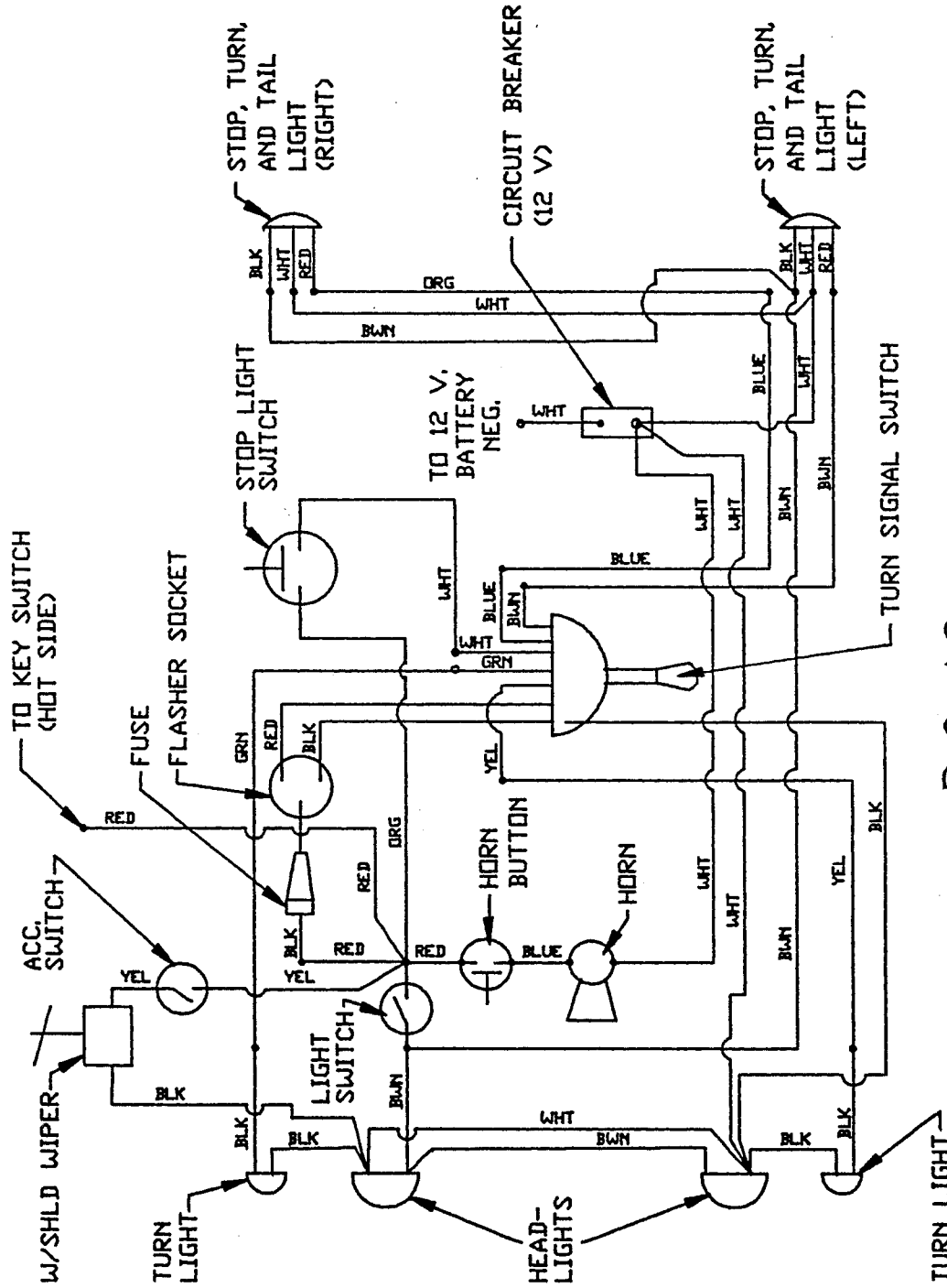

B2-10
WIRING DIAGRAM

B2104.RD6.DWG

MAINTENANCE PROCEDURES
REFER TO SECTION 3
FRONT AXLE, STEERING AND TIRES

Your front axle and wheel assembly consists of an axle mounted on 2 leaf springs with automotive spindles, steering worm, and steering linkage. It has been designed for rugged dependable service with little maintenance requirements, other than lubrication and an occasional check of all nuts and bolts for tightness. Your wheels revolve on Timken Roller Bearings and the spindles are mounted with heavy kingpins.

Zerk type grease fittings have been provided to ensure proper amounts of lubricant reaching wear points.

It is recommended that you follow the maintenance guide and lubrication diagrams for normal maintenance of the assembly. They are located in Sections 4 and 5 of this manual.

The maintenance guide is set up for average use. If the vehicle is subject to long hours of running and heavy work loads the frequency of lubrication and service should be increased accordingly.

Refer to the service and adjustment page 3, Section 10 of this manual for guidance when performing major repairs and adjustments.

If your vehicle is equipped with 4 wheel hydraulic brakes, refer to the service and adjustment section of this manual under Hydraulic Brake Section 12 for their proper care and adjustments.

The steering worm gear box and steering linkage is similar to those used on autos. It requires very little attention. Refer to Section 10 for disassemble and reassemble Steering Worm Assembly.

Refer to maintenance guide and lubrication diagrams, Sections 4 and 5 for normal care.

If service and adjustments are required, refer to appropriate section of this manual.

REMOVE AND INSTALL WHEEL HUB: ADJUST BEARINGS

1. Remove wheel cover
2. Remove dust cap
3. Remove cotter pin and unscrew spindle nut
4. Remove outer washer and bearing
5. Remove wheel, tire and hub assembly
6. Before re-assembly, thoroughly clean the bearings, spindle, and hub assembly. Inspect bearings for wear or damage. Examine inner seal. Replace damaged or worn parts.
7. Generously pack bearings with wheel bearing grease.
8. Reassemble in reverse order. Adjust wheel bearings before installing cotter pin.
9. Adjust wheel bearings by tightening spindle nut until bearing drag barely occurs, then back off spindle nut approximately 1/4 turn. Wheel should turn freely without noticeable bearing end play.
10. Install cotter pin, dust cap and wheel cover.
11. Wheel hub has one zerk fitting for periodic lubrication of bearing without disassembling hub. Refer to Lube Chart in Section 5.

SERVICE AND ADJUSTMENT
FRONT AXLE, STEERING AND TIRES continued

REMOVE AND INSTALL KING PINS AND BUSHINGS

1. Remove wheel and hub from spindle. See preceding subsection.
2. Remove ball joints from steering arms. Remove cotter pin and nut, rap stud sharply with soft hammer, or soft block and regular hammer, to loosen tapered stud from steering arm.
- 2a. Disconnect drag link ball joint at Pitman Arm, remove cotter pin and nut, rap stud sharply with soft hammer, or soft block and regular hammer, to loosen tapered stud from Pitman Arm.
3. Remove 7/8 lock nut which retains spindle and steering arm assembly to king pin.
4. Remove king pin from axle. If it is necessary to force the pin from the axle, use a soft rod, such as bronze or aluminum.
5. Remove spindle and steering arm assembly, and thrust bearing, from axle yoke.
6. Press bushings from spindle.
7. Thoroughly clean bushing housing and king pin before installing new bushings.
8. Press bushing into sleeve. If proper press is not available, most automotive supply houses and repair shops have capacity to perform this service.
9. Reassemble in reverse order. Lightly oil king pin and tap into place in axle. Where it is necessary to use force to assemble components, use a soft hammer or punch. When yoke and king pin are assembled to axle, drive king pin home to seat serrations into top yolk plate. Install nut to bearly touch lower yoke plate. DO NOT DRAW YOKE PLATES TOGETHER.
10. After reassembly, tighten ball joints securely. Lubricate bushings and king pin through grease fitting. Adjust wheel bearings as described in preceding subsection. Align front end as described in subsection titled "Align Front End: Adjust Toe-In".

ALIGN FRONT END: ADJUST TOE-IN

1. Caster and camber are set at the factory and do not require adjustment. To adjust toe-in, raise front end of vehicle off the ground.
2. With a pencil, make a mark around center of tread of tire by holding pencil point against tire while turning wheel. Mark both front tires.
3. Lower vehicle to ground. Loosen tie-rod sleeve clamps at each end of tie-rod so that adjusting sleeve can be turned.
4. With wheels in straight forward direction, measure the distance between pencil lines at the front of the tires, and the rear of the tires.
5. Adjust the tie-rod sleeve until the distance from mark to mark across the front of the tires is the same as the distance from mark to mark across the rear of the tires.
6. Tighten the adjusting sleeve clamp nuts securely, taking care to avoid changing the position of the adjusting sleeve.

REMOVE AND REPLACE BALL JOINT

1. Remove cotter pin and nut.
2. Loosen sleeve clamp.
3. Rap ball joint stud sharply with soft hammer or soft block and regular hammer to loosen tapered stud from steering arm.

SERVICE AND ADJUSTMENT
FRONT AXLE, STEERING AND TIRES continued

REMOVE AND REPLACE BALL JOINT continued

4. Either measure position of ball joint or count number of threads exposed from sleeve. Remove ball joint by unscrewing from sleeve. Note that one end will be left hand thread and the opposite ball joint will be right hand thread.
5. Install new ball joint and position same as the one removed.
6. Install tapered stud in steering arm or Pitman Arm.
7. Replace nut, tighten securely and replace cotter pin before tightening ball joint in Pitman arm. Make any necessary adjustments to coordinate (center) steering wheel when tires are aligned.
8. If ball joint replaced is part of the tie-rod, check toe-in and adjust if necessary - as described in subsection titled "Align Front End".
9. Tighten both sleeve clamps securely.
10. Lubricate ball joint through zerk fittings. Refer to Lube Chart in Section 5.

REMOVE AND REPLACE STEERING WORM ASSEMBLY

1. Pry steering wheel cap up to expose locknut.
2. Use wheel puller to remove steering wheel.
3. Remove steering arm with wheel puller.
4. Remove the 3 mounting bolts at bottom of steering assembly.
5. Remove U-bolt and lift out steering assembly.
6. Install steering gear with 3 mounting bolts.
7. Install U bolt.
8. Align wheels straight ahead.
9. Install steering wheel loosely. Center steering gear, turn full left return one and three quarters. Steering gear is now centered.
10. Install arm.
11. Center steering wheel and tighten nut.
12. Check that you will be able to turn the steering mechanism equally in both directions. If you cannot, it means the steering arm was not properly installed and it will be necessary to remove the arm and replace it in the proper position.
13. Lubricate steering worm through zerk fitting located on worm housing.

SERVICE AND ADJUSTMENT
FRONT AXLE, STEERING AND TIRES continued

DISASSEMBLE AND REASSEMBLE STEERING WORM

Refer to Figure 4, Section 10

TIRE CARE:

Tire pressure is governed by how you want your vehicle to ride and the terrain to which it is most commonly used upon.

Slightly lower pressure will assist traction on soft terrain without undue wear.

The chart listed below will assist you to determine the correct tire pressure for your needs.

=====

TIRE INFLATION CHART

TIRE SIZE	TYPE	EQUIVALENT LOAD RANGE	RATING	(COLD) INFLATION P. S. I.	TIRE LOAD RATING MAXIMUM		
					5 MPH	10MPH	15MPH
				MAXIMUM	LOAD POUNDS		
4.80-8/400-8	HIGHWAY TREAD	A	2	35	640	505	470
4.80-8/400-8	HIGHWAY TREAD	B	4	70	960	760	710
4.80-8/400-8	STEELGUARD	C	6	100	1220	960	895
5.70-8/500-8	HIGHWAY TREAD	B	4	60	1240	980	915
5.70-8/500-8	HIGHWAY TREAD	C	6	90	1520	1240	1160
5.70-8/500-8	STEELGUARD	D	8	120	1860	1470	1370
16 x 6.50 x 8	TERRA TIRE	B	4	28		620	
18 x 8.50 x 8	TERRA TIRE	B	4	22		815	
18 x 9.50 x 8	TERRA TIRE	B	4	24		1040	

=====

THE INFLATION AND LOAD RATINGS MOLDED ON HIGHWAY TREAD TIRES, PER FEDERAL STANDARD FMVSS-119, ARE FOR MAXIMUM HIGHWAY SPEEDS AND DO NOT APPLY TO THIS LOW SPEED VEHICLE.

TAYLOR-DUNN MANUFACTURING COMPANY

=====

CAUTION:

Do not over-inflate tires as this will promote increased wear. Under inflation especially on hard surfaces also promotes undue wear and should be avoided.

FRONT AXLE AND STEERING B 2-10
FIGURE 3 SECTION 10

ID NO.	PART NO.	DESCRIPTION	QTY.
1	18-311-00	Steering Gear, 27 In. Tube	1
2	19-004-50	Cover, Steering Wheel	1
3	88-199-82	5/8 NF Hex Jam Nut	1
4	18-111-00	Arm, Steering 5-3/4	1
5	19-011-00	Wheel, Steering	1
6	88-188-62	5/8 Lock Washer	1
7	88-199-81	5/8 NF Hex Nut	1
8	16-865-02	Plate, 1-3/4 Spring x 2 Sq. Axle	2
9	88-109-81	3/8 NC Locknut	8
10	21-020-00	King Pin	2
11	87-074-00	Grease Fittings	6
12	86-501-98	Ball Joint, Lt.	2
13	86-501-99	Ball Joint, Rt.	2
14	88-159-85	1/2-20 NF Hex, Slotted	1
15	88-527-11	Cotter Pin	5
16	86-510-00	Clamp, Ball Joint	4
17	18-057-11	Sleeve, Steering	1
18	18-041-00	Sleeve, Steering	1
19	15-210-00	Weldment, Axle, Front	1
20	18-527-14	Cotter Pin	2
21	88-189-81	5/8 NC Locknut	2
22	15-210-10	Assembly, Front Axle	1
23	45-338-00	Oil Seal	2
24	80-017-00	Tapered Roller Bearing	2
25	80-103-00	Tapered Bearing Race	2
26	12-124-00	Front Hub	2
27	96-329-00	Lug Bolt	10
28	97-236-00	Lug Nut	10
29	88-228-60	3/4 Washer	2
30	96-123-00	U Bolt	4
31	92-104-00	Dust Cap	1
32	10-081-00	Tire, 5.70 x 8 Load Range B, Highway Tread	0 or 2
	10-075-00	Tire, 4.80 x 8 Load Range B, Highway Tread	0 or 2
	10-093-00	Tire, 18 x 8.50 x 8, Tierra Tire	0 or 2
33	11-040-00	Tube, 5.70 x 8	0 or 2
34	12-012-00	Wheel, 4.80, 5.70 x 8, 5 Hole, Tubeless	0 or 2
		(with 13-742-00)	
		(with 13-734-00)	
	12-042-00	Wheel, 5.70 x 8, 5 Hole, Split Rim	0 or 2
		(with 13-742-10)	
		(with 13-742-11)	
	12-020-00	Wheel, 18 x 8.50 x 8 / 9.50 x 8, 5 Hole, Tbl.	0 or 2

FRONT AXLE AND STEERING B 2-10 continued
FIGURE 3 SECTION 10

ID NO.	PART NO.	DESCRIPTION	QTY.
35	13-746-00	Ass'y, Tire, Whl, 18 x 8.50 x 8	0 or 2
	13-742-00	Ass'y, Tire, Whl, 5.70 x 8 Load Range B, HT	0 or 2
	13-742-10	Ass'y, Tire, S-Rim, 5.70 x 8 Foam	0 or 2
	13-742-11	Ass'y, Tire, S-Rim, 5.70 x 8 Load Range B, HT	0 or 2
	13-734-00	Ass'y, Tire, Whl, Stem	0 or 2
36	16-870-10	Link-Plate, 2-1/4, Zinc Plated	4
37	96-248-00	Bolt-Shackle, 9/16 x 3	6
38	32-213-00	Bushing, Nylon	6
39	88-179-86	9/16-18 NF 2B, Locknut	6
40	14-210-98	Spindle, Weldment, Lt.	1
41	14-210-99	Spindle, Weldment, Rt.	1
42	97-180-55	Thrust Washer	4
43	87-077-00	Grease Fitting	1
44	32-240-55	Bushing	4
45	00-210-16	Mount Weldment, Steering Gear	1
46	02-210-34	Spacer, Steering Column	1
47	96-102-00	U-bolt, Steering Column Shaft	1
48	88-089-81	5/16 NC Locknut	2
49	88-151-16	1/2 x 2 NF Hex Screw, Gr. 5	1
50	88-151-13	1/2 x 1-1/4 NF Hex Screw	1
51	88-159-82	1/2 NF Jam Nut	2
--	85-512-10	FRONT LEAF SPRING	

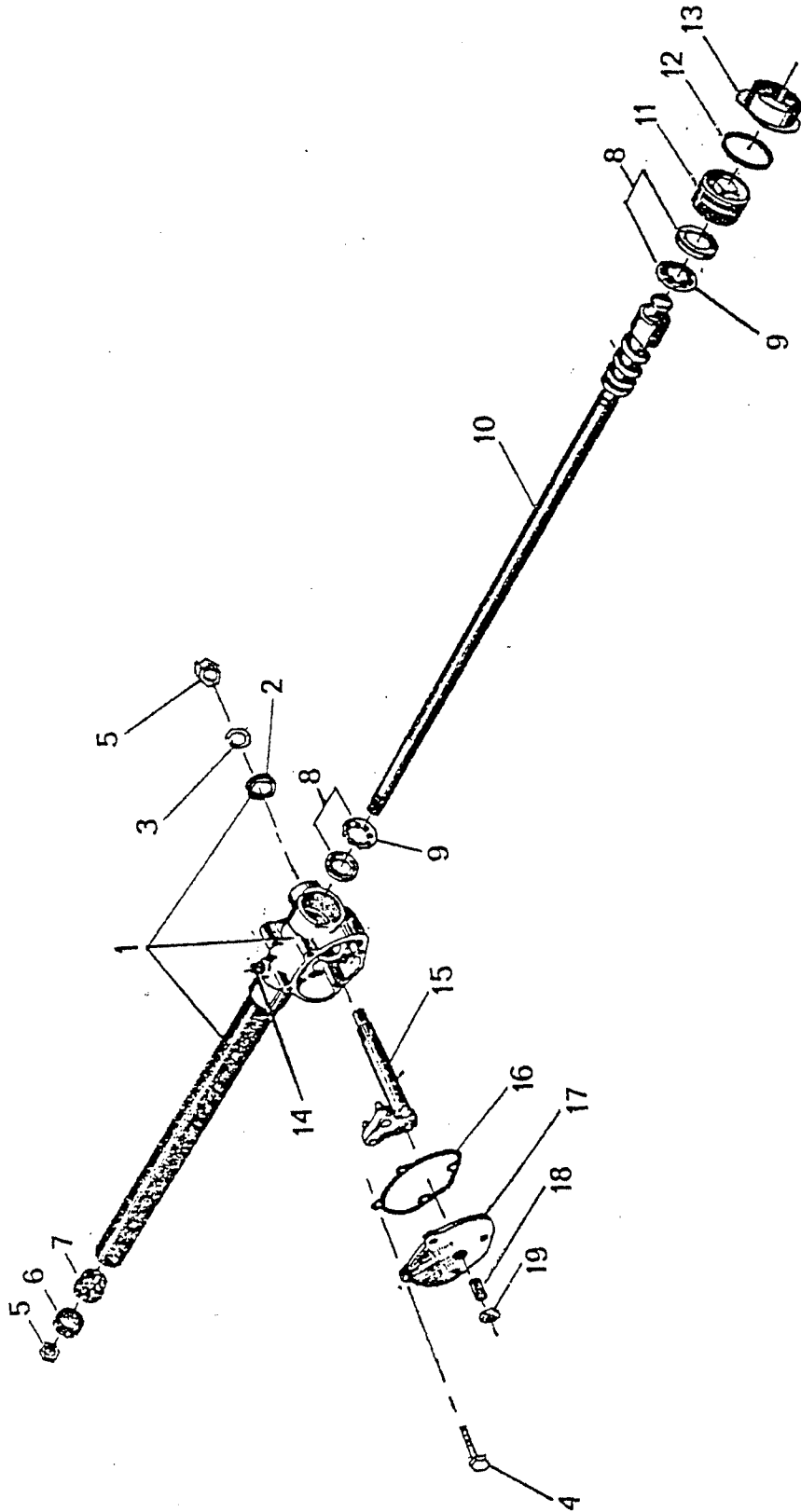

STEERING WORM ASSY B2-10

STEERING WORM ASSEMBLY
B 2-10

FIG. I.D.	PART NO.	DESCRIPTION	QTY. REQ.
1	18-311-79	Housing, With Seal & Column (45-350-00 Seal)	1
2	18-311-59	Oil Seal	1
3	88-188-62	5/8 Lock Washer	1
4	88-080-10	5/16 x 7/8 NC Hex Screw	4
5	88-199-81	5/8 NF Nut	2
6	97-200-00	Cover, Dust	1
7	18-311-55	Bearing, Column	1
8	18-311-56	Ball Cup Kit	2
9	18-311-53	Cup-Ball	2
10	18-311-51	Cam & Tube Assembly	1
11	41-972-00	End Plug	1
12	18-311-70	Seal	1
13	97-231-00	1-7/8 Lock Nut	1
14	87-077-00	Grease Fitting	1
15	18-311-78	Lever Shaft Assembly (Includes: 88-188-82 & 88-199-80)	1
16	18-311-58	Gasket	1
17	18-311-77	Side Cover	1
18	18-311-74	Adjusting Screw	1
19	88-159-82	1/2 NF Jam Nut	1
--	18-308-63	STEERING GEAR ASSEMBLY	

MAINTENANCE, SERVICE AND PARTS
POWER TRACTION (BELT DRIVE IS STANDARD)
REFER TO FIGURE 5 SEE PAGE 7 THIS SECTION

Adjustment of Drive Chain Tension - Power Traction

1. **CAUTION: Disconnect both main battery leads to prevent accidental engagement of power while servicing vehicle.**
2. Tighten three motor mounts.
3. Loosen and unscrew each nut exactly one full turn.
NOTE: This procedure is very important, for if the nuts are too loose or too tight, and error will result in the final adjustment which will seriously reduce the lift of the chain.
4. Loosen adjusting set screw lock nut. Using standard socket set screw wrench, turn set screw clockwise until tight. (If a torque wrench is available, tighten to 80" lbs. torque). Without a torque wrench, bear in mind that a standard socket set screw wrench is approximately 4" long. An average person will only be able to develop the required torque necessary if he tightens it as far as possible with his hands and does not use any extended handle on the wrench.
5. After developing the required torque, unscrew the adjusting screw exactly 2-1/2 turns. It is also very important to be exact on this adjustment.
6. Tighten locknut. DO NOT allow adjusting screw to move while tightening locknut.
7. Be certain that motor has moved all the way back and adjusting screw is in contact with back plate. If necessary, tap motor lightly to assure this condition.
8. Tighten three motor mount nuts securely.

Perform this adjustment procedure regularly as listed below to assure long and trouble free life from your "Power Traction Drive"

SCHEDULED ADJUSTMENT	AFTER	COMMENTS
1st Adjustment	100 Hours	New unit or after installing new chain
2nd Adjustment	Next 150 Hours	Normal running conditions
3rd Adjustment	Next 250 Hours	Normal running conditions
Thereafter	Every 400 Hours	Normal running conditions

Removal of "Power Traction" Rear Axle & Drive Assembly From Chassis

1. Disconnect one battery lead to prevent accidental engagement of power while serving unit.
2. Clearly mark motor leads to ensure their proper location when re-assembling.
3. Remove motor leads.
4. Disconnect hydraulic brake line hoses.
5. Disconnect brake rods at calipers
6. Remove Shackle Bolt clamp and nuts attaching spring to frame.
7. Remove axle and drive assembly from chassis.
8. Install axle and drive assembly in the reverse order of removal, taking care that support pads and bushings are in good condition (Replace if worn or damaged.)
9. Check brake adjustments as outlined in Section 12.
10. It will be necessary to bleed the air from brake system. Follow procedure outlined in Hydraulic Brake Section 12.

Disassembly of "Power Traction" Rear Axle

1. Remove unit from chassis (As previously outlined).
2. Remove wheels and drain oil from housing.
3. Remove nuts and bolts, and remove drive case cover.
4. Remove 3 nuts and washers and remove motor and mount plate. (If motor requires further service, refer to appropriate Section 11 of this manual).
5. Remove chain and pinion sprocket. Observe location of spacers on shaft. Refer to Figure 5 for their correct location.
6. Remove five bolts holding back plate and remove from carrier housing.
7. Disconnect hydraulic line.
8. Remove four bolts on each end holding axle retainer / brake holding plate and pull both axles.
9. Remove nuts around differential carrier housing and remove carrier from axle housing. (Note position of clip for proper reassembly of brake spring.)
10. Mark one differential bearing cap and bearing support to ensure proper assembly. Remove adjusting nut locks, bearing caps, and adjusting nuts.
11. Remove drive gear from differential case.
12. Drive out differential pinion shaft retainer and separate the differential pinion shaft and remove gears and thrust washers.
13. Remove drive pinion retainer from carrier. Remove O-ring from retainer.
14. Remove pinion locating shim. Measure shim thickness with micrometer.
15. If the drive pinion pilot bearing is to be replaced, drive the pilot end and bearing retainer out at the same time. When installing, drive the bearing in until it bottoms. Install a new retainer with the concave side up.

Disassembly of "Power Traction" Rear Axle continued

18. Press the pinion shaft out of front bearing cone and remove spacer.
19. Remove pinion bearing cone.
20. Do not remove pinion bearing cups from retainer unless they are worn or damaged. The flange and pilot are machined by locating on these cups after they are installed in the bores. If new cups are to be installed, make sure they are seated in the retainer by trying to insert a .0015" feeler gauge between cup and bottom of bore.

Re-Assembly of Power Traction Rear Axle

1. Differential Case: Place a side gear and thrust washer in the differential case bore. LUBRICATE ALL PARTS LIBERALLY WITH AXLE LUBRICANT DURING ASSEMBLY. With a soft faced hammer, drive pinion shaft into case only far enough to retain a pinion thrust washer and pinion gear. Place the second pinion and thrust washer in position. Drive the pinion shaft into place. Be careful to line up pinion shaft retainer holes. Place second side gear and thrust washer in position and install differential case cover. Install retainer. A pinion or axle shaft spline can be inserted inside gear spline to check for free rotation of differential gears. Insert two 7/16" x 2" bolts through differential flange and thread them three or four turns into the drive gear as a guide in aligning the drive gear bolt holes. Press or tap the drive gear into position. Install and tighten the drive gear bolts ly and alternately across the gear to 60-65 lb. ft. torque.
 2. If the differential bearings have been removed, use a suitable press to install them.
 3. Pinion and Retainer: Install pinion rear bearing cone on the pinion shaft. Install spacer with shims on shaft. Place the bearing retainer on the pinion shaft, and install the front bearing cone.
 4. Lubricate both bearings with differential oil. Place spacers, sprocket and drum on spline with nut and washer and tighten to 100 lb. ft. torque.
- NOTE: The bearing should spin free but have no play. If tight or loose, adjust with .005" and .019" shims.

5. Shim Selection: Manufacturing tolerances in the pinion bore dimensions and in the best operating position of the gears make an adjustment shim necessary. This shim is place between the pinion retainer and the carrier, Figure 5. An increase in the thickness of the shim moves the pinion AWAY from the drive gear. manufacturing objectives are to make axles requiring a .0015" shim and if a new assembly is being built, a .0015" shim should be used for a tentative build-up. Shims are available in .010" to .021" thicknesses in steps of .001". Pinions and drive gears are marked, when matched with the same number. Following the number on the pinion is a minus (-) or plus (+) followed by a number. If the pinion is marked "-1" it indicates that a shim .001" thinner than a standard shim for this carrier is required. A minus number means the pinion should be moved closer to the drive gear and a thinner shim is required. A plus number means the pinion should be moved farther from the drive gear and a thicker shim is required. A pinion marked zero (0) is a standard pinion.

Re-Assembly of Power Traction Rear Axle

5. (continued)

- To select a shim, measure the original shim with a micrometer. Note the dimensional mark on the original pinion. Compare the mark on the original pinion with the mark on the new pinion to determine how the original shim should be modified. For example, if the original shim is .015" and the original pinion is marked "-1", the new pinion requires a +1 shim. Therefore, the new pinion requires a .002" thicker shim, and a .017" shim should be used. If the new pinion is marked the same as the old pinion, no shim change is required.
6. After the proper selection of shims, insert "O" ring seal and pinion retainer assembly into differential carrier. Tighten 5 retainer bolts to 50 lb. ft. torque. (Note: The 5 bolts will have to be removed later to install back plate assembly.)
 7. Install differential case, bearing cups, adjusting nuts, and bearing caps being sure that each cap is located in the same position from which it was removed. (Use marks as guide)
 8. ADJUST bearing nuts so that differential case will be free to revolve. It is very important that there will be no bearing play or looseness, as this will inevitably lead to gear noise and wear. Gear backlash must be set at the same time to a tolerance of .005" to .009". Note: it will be necessary to release some of the cap bolt tension in order to allow the bearing to move while making the adjustments. If the caps are too loose an error will result when trying to set backlash and bearing clearance. Therefore, double check your setting after the cap bolts have been tightened. If necessary, make corrections near settings until their specified tolerances are maintained after the cap bolts have been tightened.
 9. Install nut locks.
 10. Install differential carrier assembly in axle housing using new gasket and gasket sealer.
 11. Install axles, brake assemblies, bearing retainers, and gaskets. Note: Axles are equipped with special sealed bearings. Should there be evidence of seal leakage, it is recommended that a new bearing and new bearing retainer ring be pressed onto the axle shaft, and a new gasket be installed between the bearing and bearing seat in the housing. Refer to figure 5.
 12. Install gasket (use gasket sealer) and back plate assembly. Tighten 5 bolts to 50 lb. ft. torque.
 13. Install spacers, sprockets and chain in the reverse order to which they were removed. Take care that 3/16" woodruff key is in proper position and all spacers are in original position. Tighten 3/4" motor shaft nut to 75 lb. ft. torque (if sprocket was removed from motor).
 14. Install motor and motor mount plate with "O" ring. Do not tighten 3 nuts until final adjustment is made. Be sure motor terminals are located in the same position as when motor was remove.
 15. Install pinion shaft washer and nut. Tighten to 100 ft. lb. torque.
 16. Install gear case cover to back plate and pinion shaft. Assemble, but do not tighten, retaining bolts and nuts.

Re-Assembly of Power Traction Rear Axle continued

17. Tighten gear case cover retaining bolts and nuts.
18. Replace wheels and fill chain and differential housing with approximately 2 qts. SAE 30 oil.
19. Replace unit in chassis following steps 10 to 12 outlined in Section titled "Removal of Power Traction Rear Axle", page 2, section 11
20. Adjust motor mount plate (as outlined in Motor Adjustment Section following) to proper chain tension.

Adjustment of Motor Mount To Tension Chain

1. Tighten three motor mount nuts.
2. Loosen and unscrew each nut exactly one full turn.
Note: This procedure is very important for if the nuts are too loose or too tight an error will result in the final adjustment which will seriously effect the life of the chain.
3. Loosen adjusting set screw lock nut. Using standard socket set screw wrench, turn set screw clockwise until tight. (If a torque wrench is available, tighten to 80 inch lbs. torque.) Without a torque wrench bear in mind, that a standard socket set screw wrench is approximately 4" long. An average person will only be able to develop the required torque necessary if he tightens it as far as possible with his hands and does not use any extended handle on the wrench.
4. After developing the required torque, unscrew the adjusting screw exactly 2-1/2 turns. It is also very important to be exact on this adjustment.
5. Tighten locknut, DO NOT allow adjusting screw to move while tightening locknut.
6. Be certain that motor has moved all the way back and adjusting screw is in contact with back plate. If necessary, tap motor lightly to assure this condition.
7. Tighten three motor mount nuts, securely.

Perform this adjustment procedure regularly as listed below to assure long and trouble free life from your "Power Traction" Drive.

SCHEDULED ADJUSTMENT	HOURS RUNNING	COMMENTS
1st Adjustment	0	New Unit or After Installing New Chain
2nd Adjustment	Next 100 Hrs.	Normal Running Conditions
3rd Adjustment	Next 150 Hrs.	Normal Running Conditions
4th Adjustment	Next 250 Hrs.	Normal Running Conditions
Thereafter	Every 400 Hrs.	Normal Running Conditions

Removal of Motor For Minor Repairs

1. **CAUTION:** Disconnect both main battery leads to prevent accidental engagement of power while servicing unit.
2. Drain oil from gear case by removing drain plug.
3. Remove all bolts and Nuts around gear case cover.
4. Remove gear case cover.
5. Clearly mark motor leads to ensure their proper location when re-assembling. Remove motor leads.
6. Remove 3 nuts and washers and remove motor and mount plate.
7. When replacing motor, remove nut, washer, sprocket, and spacers, also remove motor mount plate. NOTE: Observe location of motor terminals in relation to motor mount plate.

Install Motor in "Power Traction" Drive

It is not necessary to remove motor mount plate when performing minor motor repairs. Therefore, follow step 1 only when replacing motor with new one.

1. Clean motor surface and install mounting plate with four flat head cap screws. Tighten to 30 lb. ft. torque. Stake head in place with centerpunch. NOTE: it is important to locate the motor mount plate in relation to the motor terminal so that the motor terminals will be in an accessible location when drive is completely assembled.
2. Place "O" ring into motor mount plate opening and attach motor and plate to back plate.
3. Re-assemble drive in the reverse order to that removal.
4. Adjust motor mount to obtain proper chain tension.
5. Refill gear case with SAE 30 oil.
6. **CORRECT MOTOR LEADS AS FOLLOWS: (IMPORTANT!)**
 - a. Check that each motor terminal stud nut is tightened securely but not over-tightened as this could bend or twist the terminal post and cause an electrical short within the motor.
 - b. Install motor leads on correct motor terminals post.
 - c. Install a second nut on each terminal post and finger tighten.
 - d. To avoid bending, twisting or breaking-off a terminal post, use a thin pattern 9/16" wrench to hold the bottom nut from moving while tightening the top nut. Carefully tighten the top nut so as to make a good connection between the terminal post and motor lead.

Motor Repairs

Unless the maintenance man is properly qualified, it is advisable that repair work be done at a qualified service station. When ordering replacement parts, give complete name plate data.

Disassembly of Motor (Refer to Section 13)

Belt Tension Adjustment and Alignment - Belt Drive Vehicles

NOTE: New belts will 'seat-in' rapidly, therefore, readjust belt tension after only a few hours of running to prevent undue slippage and wear. It may be necessary to repeat the adjustment procedure two or three times within the first week or two of running until the new belts become thoroughly 'seated in'.

1. Disconnect one battery lead to prevent accidental engagement of power while servicing unit.
2. Loosen motor mount clamp nuts slightly.
3. Loosen motor adjusting bolt lock nut and turn adjusting bolt in or out as needed to tension belts properly.
NOTE: Belt tension is correct when belts will deflect between 1/4" and 3/8" at the mid point between pulleys. Press each belt firmly at the mid point with your thumb or finger and measure the deflection at the same point.
4. Rotate drive pulley sufficiently so belts will travel at least one full turn and check belt tension again. This will allow belts to seat properly in grooves. Repeat tension adjustment as necessary until satisfactory results are obtained.
5. Tighten lock nut on tension adjustment bolt, holding bolt in position with one wrench while tightening lock nut with second wrench.
6. Check pulley alignment with straight edge. If misaligned, move motor forward or rearward on its mounting bracket to bring pulleys into alignment. If necessary tap motor mount bracket into position with soft hammer.
7. Retighten motor mount clamp nuts securely.

Replacement of Belts - Belt Drive Vehicles

1. CAUTION: Disconnect both main battery leads to prevent accidental engagement of power while servicing unit.
2. Loosen motor mount clamp nuts slightly.
3. Loosen motor adjusting bolt lock nut and turn adjusting bolt in until belts can be easily lifted from pulley grooves without prying or forcing. Remove old belts.
4. Install a full set of new belts of equal length. Replacement of only a part of the set will prevent obtaining proper tension of all belts. This will cause unequal division of load among the belts with abnormal wear as a result.
5. Adjust tension and alignment as described in preceding section.

Remove and Install Motor - Belt Drive Vehicles

1. CAUTION: Disconnect both main battery leads to prevent accidental engagement of power while servicing unit.
2. Loosen motor mount clamp nuts slightly.
3. Loosen motor adjusting bolt lock nut and turn adjusting bolt in until belts can be easily lifted from pulley grooves without prying or forcing. Remove belts.
4. Clearly mark motor leads to assure proper location when reassembling. Remove motor leads.
5. Remove motor mount clamp nuts and clamp. Remove motor and mounting brackets from axle housing.

Remove and Install Motor - Belt Drive Vehicles (continued)

6. If installing new motor, remove motor shaft nut, pulley, and key from old motor. Also remove motor mounting brackets and screws. For information on maintenance of motor, refer to Section 13.
7. If installing new motor, assemble pulley, key and shaft nut. Tighten shaft nut to 75 ft. lb. torque.
8. Reassemble drive axle assembly in reverse order. Adjust and align belts as described in sub-section titled "Belt Tention Adjustment and Alignment Belt Drive Vehicles".

Disassembly and Reassembly of Belts and Pulleys - Belt Drive Vehicles

1. Perform Steps 1 through 5 in sub-section titled "Remove and Install Motor Belt Drive".
2. Remove differential pinion gear, shaft nut, washer, pulley and spacers from differential pinion gear shaft.
3. Reassemble in reverse order.
4. Before reconnecting battery lead, adjust belt tension and alignment as described in sub-section titled "Belt Tension Adjustment and Alignment - Belt Drive Vehicles".
5. Reconnect battery lead.

CAUTION: Motor Lead Connection Procedure

- a. Check that each motor terminal stud nut is tightened securely but not over-tightened as this could bend or twist the terminal post and cause an electrical short within the motor.
- b. Install motor leads on correct motor terminal post.
- c. Install second nut on each terminal post and finger tighten
- d. To avoid bending, twisting or breaking-off a terminal post, use a thin pattern 9/16" wrench to hold bottom nut from moving while tightening the top nut. Carefully tighten the top nut so as to make a good connection between the terminal post and motor lead.

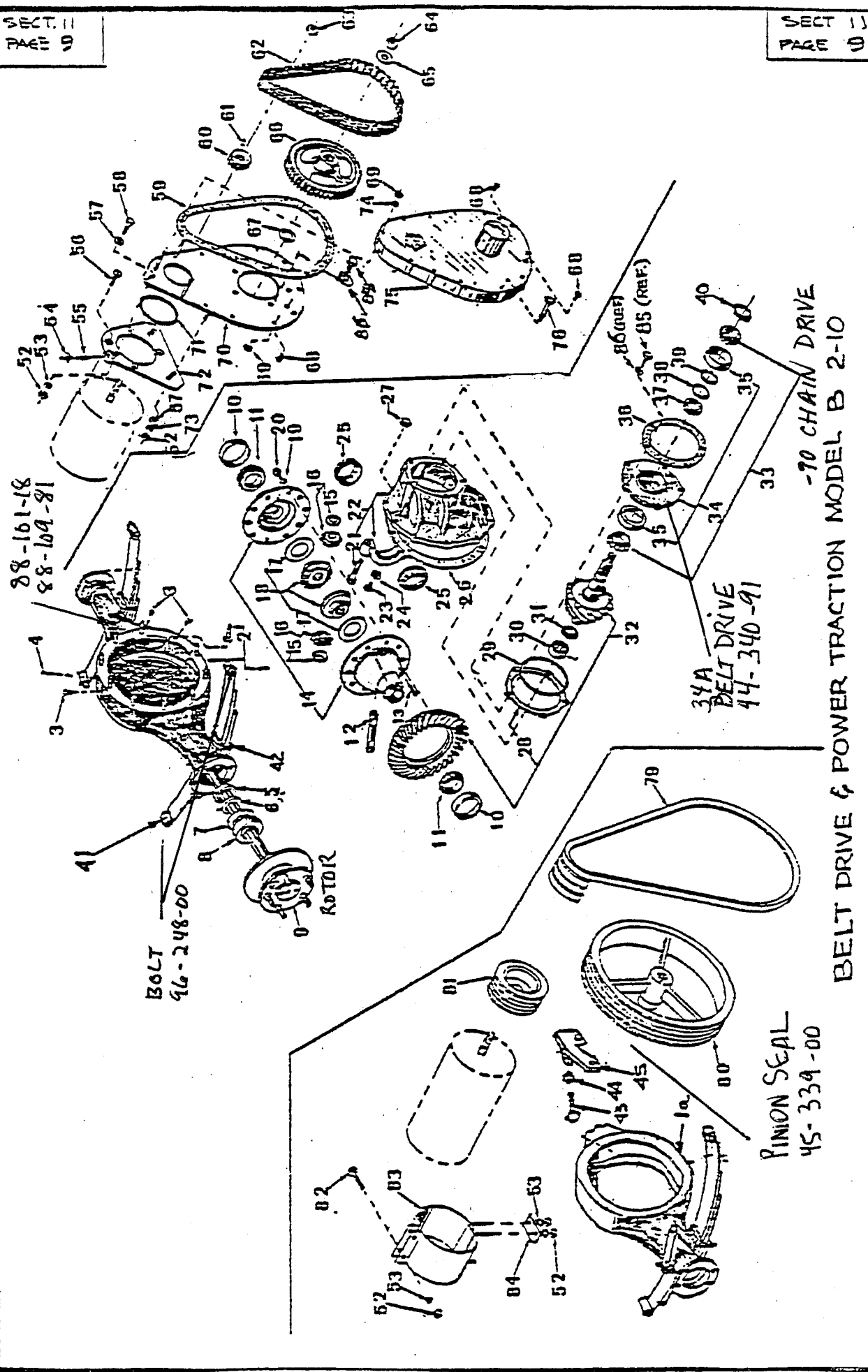

88-161-18
88-164-81

BOLT
96-248-00

ROTOR
0

34A
BELT DRIVE
44-340-91

70
CHAIN DRIVE

PINION SEAL
45-339-00

BELT DRIVE & POWER TRACTION MODEL B 2-10

B 2-10 BELT DRIVE & POWER TRACTION PARTS LIST
SECTION 11 FIGURE 5

FIG I.D.	PART NO.	DESCRIPTION	QTY.
1	41-291-11	Housing, Chain Drive	1
1a	41-291-10	Housing, Belt Drive	1
2	96-330-00	Bolt, Diff.	10
3	41-997-00	Plug, Drain	3
4	88-527-11	Pin, Cotter	1
5	45-301-00	Seal, Oil	1
6	32-515-00	Retainer Ring	2
7	45-044-00	Gasket	2
8	80-503-00	Brg, Ball, Axle	2
9	41-152-10	Axle Assembly	2
10	80-127-00	Race, Brg, Tapered	2
	80-128-00	Race, Brg, Tapered	0 or 2
	80-129-00	Race, Brg, Timken LM102949	0 or 2
11	80-511-00	Brg, Tapered Roller	2
	80-512-00	Brg, Tapered	0 or 2
	80-513-00	Brg, Roller, Timken LM102949	0 or 2
12	41-700-00	Shaft, Diff. Pinion	2
13	41-701-00	Pin, Tension	2
14	44-340-10	3rd Member 2.69/2.70/2.75/2.91	1
	44-340-12	3rd Member 3.00 Ratio	0 or 1
	44-340-14	3rd Member 3.50/3.56/3.70	0 or 1
15	41-702-00	Thrust Washer	2
16	41-703-00	Kit, Diff. Shaft Pinion	1
17	41-704-00	Thrust Washer	2
18	41-705-00	Kit, Diff Side Gear	1
19	97-163-00	Washer, 7/16 ID x 3/4 OD	10
20	88-130-10	7/16 x 7/8 NF Hex Head	10
21	88-140-16	1/2 x 2 NC, Hex Head	4
22	41-710-00	Diff. Housing	1
23	88-080-04	5/16 x 3/8 NC Hex Head	2
24	41-706-00	Nut Lock, Adj. Diff. F2	2
	41-706-50	Nut Lock, Adj. Diff. F2	2
	41-706-51	Nut Lock, Adj. Diff. F2	2
25	41-707-00	Nut, Diff Brg Adj F2	2
	41-707-50	Nut, Diff Brg Adj F2	2
	41-708-00	Nut, Diff Brg Adj F2	2
	41-708-50	Nut, Diff Brg Adj F2	2
26	45-042-00	Gasket, Diff. Hsg.	2
27	88-119-80	Nut, 3/8 NF	14
28	41-711-00	Shim, Pinion	1 to 3
29	80-702-00	O-Ring, Pinion	1
30	80-555-00	Brg, Ball Pinion	1
31	41-714-00	Retainer, Brg	1
32	31-234-00	Ring and Pinion Gear Set 3.00 Ratio F2	1
	31-235-00	Ring and Pinion Gear Set 2.75 Ratio F2	1
	31-238-00	Ring and Pinion Gear Set 3.50 Ratio F2	1
	31-239-00	Ring and Pinion Gear Set 5.43 Ratio F2	1
33	80-554-00	Brg., Tapered Roller	2
34	44-340-90	Pinion Case Assembly	1
35	80-125-00	Race	1

B 2-10 BELT DRIVE AND POWER TRACTION PARTS LIST continued

FIG I. D.	PART NO.	DESCRIPTION	QTY.
36	45-021-00	Gasket	1
37	16-415-00	Spacer .440	1
38	16-419-00	Spacer .002	2 to 6
39	16-411-00	Spacer .005	2 to 6
40	16-420-00	Spacer .010	2 to 6
41	85-513-00	Springs	2
42	16-861-00	Spring Pads	2
43	96-316-00	Bolt	1
44	88-149-80	Nut	1
45	41-381-10	Motor Adj.	1
52	88-109-80	Nut, Hex Head 3/8 NC	2
53	88-108-62	Lock Washer 3/8	2
54	88-089-80	Nut, Hex Head, 5/16 NC	1
55	88-087-11	Screw, Set 5/16 x 1	1
56	88-103-09	Screw, Cap 3/8 x 3/4	4
57	88-108-60	Washer, 3/8	4
58	88-100-13	Screw, Hex Head Cap, 3/8 x 1-1/4	6
59	45-002-00	Gasket, Gear Case	2
	45-021-00	Gasket, Gear Case	2
60	30-080-00	Sprocket, 15 Tooth	1
61	97-100-00	3/16 Woodruff Key	1
62	30-508-20	Chain, SSG	1
63	88-239-82	Jam Nut, 3/4 NF	1
64	97-250-00	Nut, Pinion, 3/4-20 Extra Fine Thread	1
65	88-228-61	3/4 SAE Washer	1
66	30-093-00	Sprocket, 18 Tooth 81 30-094-00	1
67	16-400-00	Spacer	1
68	41-989-00	Plug, Drain	3
69	88-089-81	5/16 NC Locknut	12
70	44-352-53	Back Plate, Chain Case	1
71	80-703-00	O-Ring, 4-1/2 ID x 5 OD	1
72	70-454-00	Plate, Motor Mount	1
73	88-108-62	3/8 Lock Washer	3
74	88-088-61	5/16 SAE Washer	12
75	43-201-30	Cover, Chain Case	1
76	88-080-20	5/16 x 3 NC Hex Head Screw	9
79	30-620-00	Belt, 3V x 400	0 or 4
80	30-121-10	Pulley, 4 Belt 10.6	1
81	30-169-00	Pulley, 2.65 OD	0 or 1
	30-159-00	Pulley, 4 Belt 3.0	0 or 1
82	88-101-18	3/8 x 2-1/2 NC, Gr. 5	2
83	70-434-00	Mount, Motor	1
84	70-422-00	Strap, Motor Mount	1
85	88-101-13	Bolt, Hex Head 3/8 NC x 1-1/4 Gr. 5	10
86	88-108-63	Washer, Int., Tooth 3/8	10
87	16-418-00	Spacer, 15/16 ID x 1-5/8 OD x .140 thick	0 or 1
88	45-339-00	Oil Seal, Drive Pinion Shaft 3" OD	0 or 1

MAINTENANCE PROCEDURES
HYDRAULIC DISC BRAKE SYSTEM

The hydraulic disc brake system consists of three primary sub-systems.

- 1) The master cylinder with fluid lines.
- 2) The mechanical control linkage, foot brake interconnections to the caliper assemblies.
- 3) The caliper assembly as it mounts to housing.

Each rear wheel is fitted with a hydraulic (calipers) disc brake assembly.

Refer to Maintenance Guide Section 4 and Lubrication Diagram Section 5 for proper lubrication and frequency of inspection.

Master cylinder fluid level should be checked monthly. Add fluid as needed to maintain level 3/8" to 1/2" from top of fill port. Use only approved hydraulic brake fluid, DOT #5, silicone. This fluid gives longer system life and reduces maintenance. It is perfect for hydraulic disc brakes.

A visual inspection of the hydraulic system is recommended on a monthly basis to detect any signs of leakage. Repairs should be made immediately if leakage is discovered.

A spongy action on brake pedal or a low engagement point on pedal usually indicates air entrapment.

SERVICE AND ADJUSTMENT
HYDRAULIC BRAKE SYSTEM

The loss of brake pedal action may be due to a defective master cylinder. It can usually be detected by signs of fluid leakage at master cylinder or by the action of the brake pedal. When foot pedal pressure is applied you will feel the brakes engage, yet, the pedal will continue to travel downward. A ruptured hydraulic line or a defective wheel cylinder will produce the same action. You can determine the cause by the location of brake fluid leakage. Adjust dead man brake at rear, on rods. NOT under seat. Under seat is initial factory setting requiring no changes.

MASTER CYLINDER REPAIR OR REPLACE

1. Remove cotter pin, clevis pin, and remove push rod. (It will slide out of master cylinder socket).
2. Disconnect hydraulic line at cylinder. (There will be 2 lines on 4 wheel brake system.)
3. Remove 2 holding bolts and lift master cylinder out of chassis.
4. Cylinder should be thoroughly cleaned.
5. Remove boot and locking ring.
NOTE: Piston parts are under spring pressure, take care that they do not pop out when you remove lock ring.
6. Remove piston and cup assembly.
7. Inspect cylinder wall. If scoring or roughness is present it must be removed with a fine hone.

MASTER CYLINDER REPAIR OR REPLACE continued

8. Taking care that all parts are kept clean, install new piston and cut assembly kit. A diagram is furnished with each kit. It is also recommended that parts are coated with a small amount of brake fluid prior to assembly.
9. Replace lock ring and boot.
10. Install cylinder in chassis in reverse order to which it was removed.
11. ADJUST push rod by loosening locknut and shortening or lengthening the rod so that when brake pedal is fully raised the push rod should be within 1/16" of contacting piston socket. A good way to be certain is to remove clevis pin. While lightly holding rod against socket (DO NOT PUSH HARD ENOUGH TO MOVE PISTON) observe the alignment of clevis and hole. When correct you will have to pull rod approximately 1/16" out of socket to insert clevis pin.
12. Tighten locknut and install cotter pin.
13. Fill master cylinder to top with DOT #5 brake fluid or, if available, attach brake bleeder tank to master cylinder.
14. When using bleeder tank, loosen air bleeder valve (located at each wheel cylinder), one at a time. Allow fluid to flow until air pockets and bubbles stop and a clear stream appears.

WHEN BLEEDER TANK IS NOT AVAILABLE

It is necessary to utilize 2 people to bleed brake system when bleeder tank is not available. One person will operate brake pedal and add fluid to master cylinder as needed. The other person will operate bleeder valves. While one person applies brake pedal pressure, loosen bleeder valve. Fluid and air will be forced out on the downward stroke of the pedal. The person operating pedal must hold it down at the end of its stroke while the other person closes bleeder valve. If pedal is raised while bleeder valve is open air will be drawn back into the system. By coordinating the movements of the 2 people, air will be bled out by each downward stroke of the pedal. It is wise to refill master cylinder after every 3 or 4 strokes to ensure against any air being drawn in because of the reservoir level being too low. Usually 2 to 4 strokes per wheel cylinder is sufficient to remove air from system.

15. Allow vehicle to sit 15 minutes to stabilize. (Air bubbles can be trapped in silicone brake fluid and must be allowed to collect.) Repeat step 2, one more time.
16. Remove brake bleeder tank if used. Fill master cylinder 3/8" to 1/2" of top and replace cover.

REMINDER: USE DOT #5 BRAKE FLUID

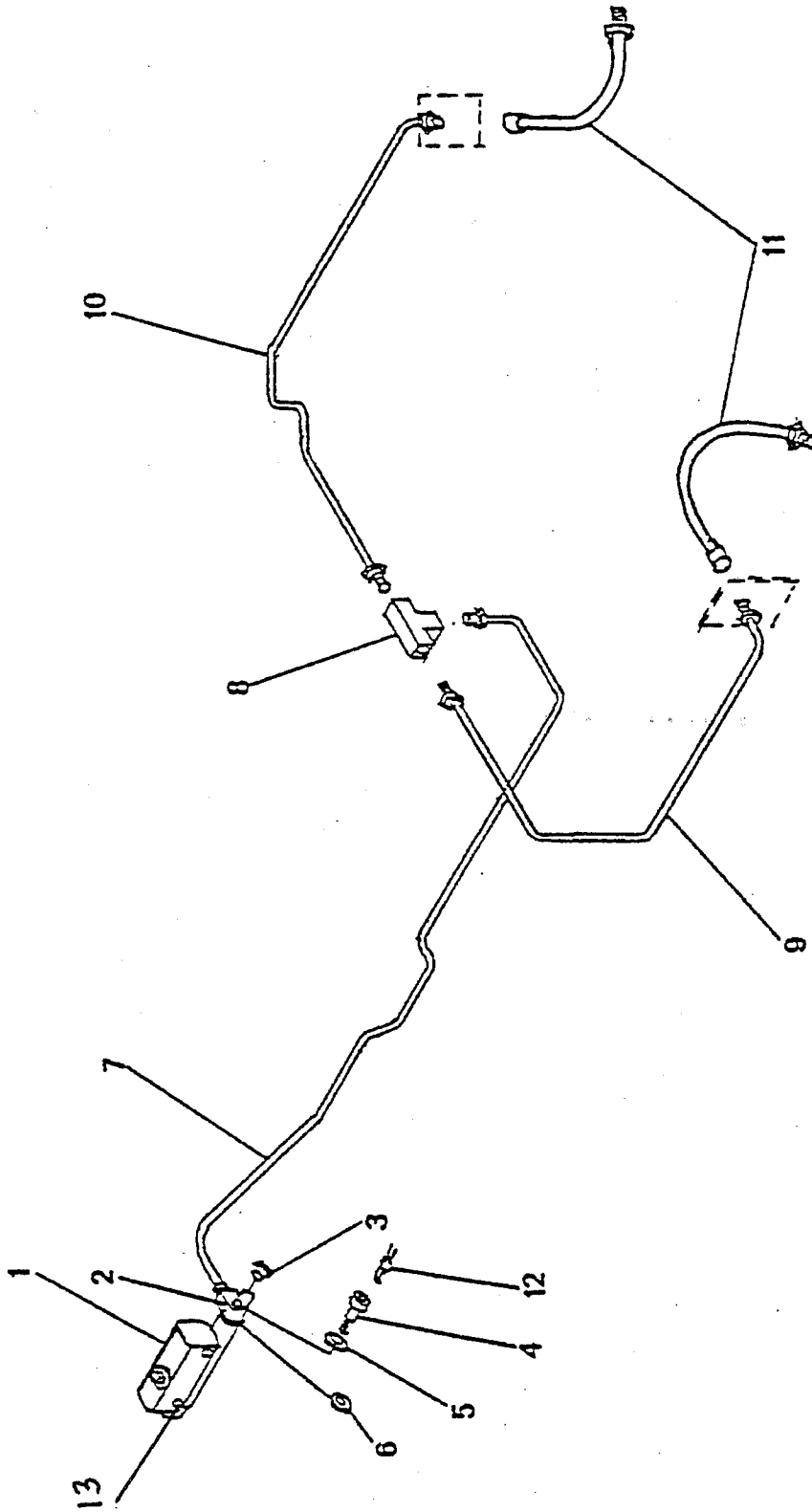

B 2-10
HYDRAULIC BRAKE
SYSTEM

HYDRAULIC BRAKE SYSTEM
B 2-10

FIG. I. D.	PART NO.	DESCRIPTION	QTY.
6-1	99-510-01	Master Cylinder	1
6-2	99-565-00	Y-Fitting	1
6-3	99-598-00	Fitting, 3/16 Tube Seat Plug (Not Needed With Front Hydraulic Disc Brakes)	1
6-4	99-578-00	Bolt for Stop Light	1
6-5	99-572-00	Washer, Wagner # FC603	1
6-6	99-571-00	Washer	1
6-7	99-607-51	Brake Line, Formed, 3/16 x 51	1
6-8	99-564-00	Union T, 3/16 Inv. Flare	1
6-9	99-605-55	Brake Line, Formed, Left	1
6-10	99-605-56	Brake Line, Formed, Right	1
6-11	99-580-20	Hydraulic Hose	2 or 4
6-12	71-110-00	Switch, Brake Light, Hyd.	1
6-13	50-009-00	PUSH ROD FRONT HYDRAULIC DISC BRAKES (OPTIONAL)	
6- 13 14	99-603-54	Line, Front Hydraulic Disc Brake	1
6- 14 15	99-603-53	Line, Front Hydraulic Disc Brake	2
6- 15 16	99-576-00	Clip, Wagner FC50358	2

MAINTENANCE PROCEDURES
MECHANICAL CONTROL LINKAGE

The mechanical control linkage operates the various controls and mechanisms located throughout your vehicle.

The accelerator system consists of the operating pedal and pivot shaft assembly, the connecting rods and adjusters and the return spring. All wear points should be lubricated monthly for normal service.

The foot brake system consists of the foot pedal, pivot shaft, the master cylinder and push rod assembly.

The automatic deadman brake system consists of the pivoted seat assembly, the operating rod, the brake apply spring, adjustable tension device and its connecting linkage.

All wear points should be lubricated monthly. Refer to Maintenance Guide Section 4 and Lubrication Diagram Section 5 for proper application of lubricants.

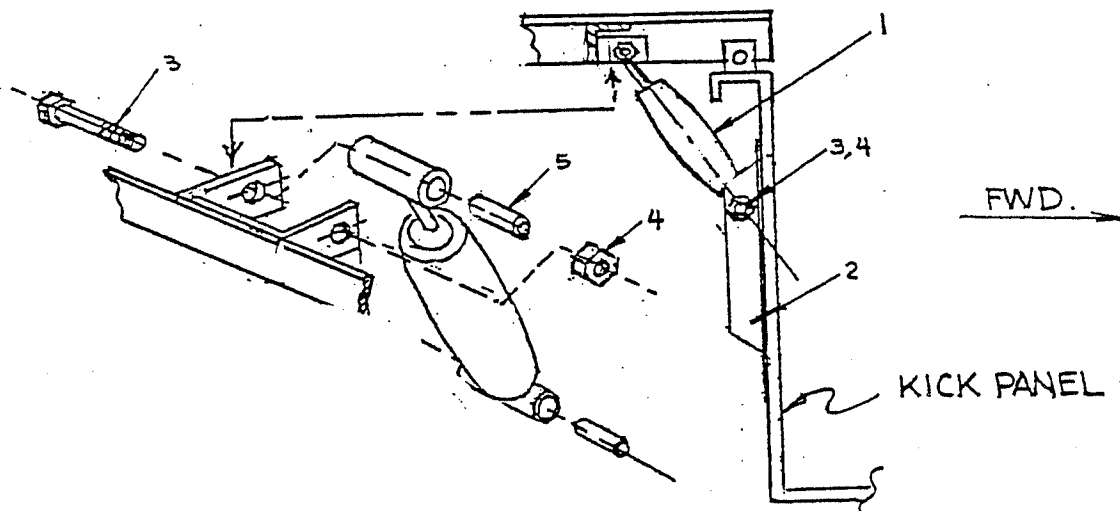

Cross Section Seat and Kick Panel
DEADMAN SEAT, SHOCK ABSORBER LINKAGE

FIG. I.D.	PART NO.	DESCRIPTION	QTY.
1	86-007-00	Shock Absorber	1
2	00-210-31	Mount, Shock Absorber	1
3	88-080-15	Screw, 5/16 x 1-3/4 NC Hex Head Cap	2
4	88-089-81	Nut, Lock 5/16 NC	2
5	32-207-10	Bushing, Shock Absorber 3/8 ID x 5/8 OD X 1 IN. Long	2

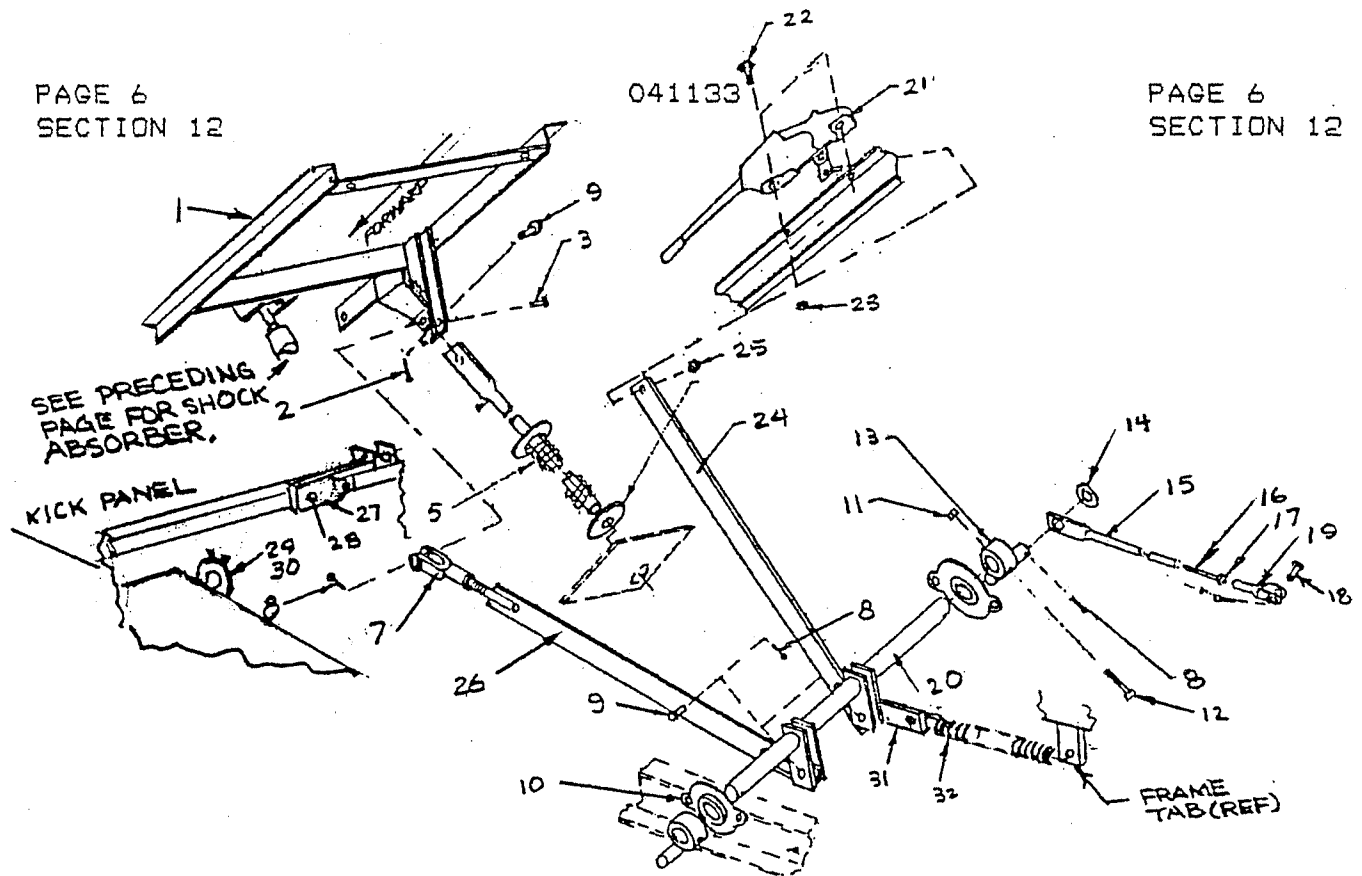

DEADMAN SEAT BRAKE LINKAGE

FIG. ID.	PART NO.	DESCRIPTION	QTY. REQ.
1	00-210-03	Base, Brake Seat	1
2	88-507-06	Pin, Cotter, 1/16 x 1/2	3
3	96-773-10	Pin, Clevis, 5/16 x 1-1/8	1
4	00-210-06	Rod, Brake Push	1
5	85-123-00	Spring, Deadman Seat	1
6	88-228-61	Washer, 3/4 SAE	1
7	96-762-00	Clevis, 3/8 In. Cast	2
8	88-517-09	Pin, Cotter, 3/32 x 3/4 Steel	4
9	96-772-00	Pin, Clevis, 3/8 x 1	2
10	80-410-20	Bearing, 2 Bolt Flg., Brk. Sft., 3/4	2
11	88-069-81	Locknut, 1/4 NC	2
12	88-060-14	Screw, 1/4 x 1-1/2 NC, Hex	2
13	00-210-05	Rotor, Brake Rod	2
14	88-108-60	Washer, 3/8	2
15	02-210-01	Rod, Park Brake	2
16	96-343-00	Screw, Brake Adjusting	2
17	88-099-80	Nut, 5/16 NF Hex	2
18	96-773-00	Pin, Clevis, 5/16 x 1	2
19	96-763-00	Clevis, 5/16 In. Cast	2
20	00-210-25	Weldment, Brake Cross Shaft	1
21	51-343-00	Lever, Hand Park Brake W/Arm	1
22	88-080-09	Cap Screw 5/16" x 3/4 NC	2
23	88-089-81	Locknut 5/16" NC	2
24	02-210-57	Bar, Brake Lever	1
25	88-109-81	Locknut, 3/8 NC	1
26	02-210-50	Link, Brake Seat	1
27	71-135-01	Micro-Switch	1
28	88-019-86	Locknut 6-32, Fiber Insert	2
29	73-004-00	Horn, 12 Volt Miniature	1
30	88-738-10	Rivet, 15/64" AL, split Lock	2
31	02-210-72	Link, Spring	1
32	85-295-00	Spring, Extension 9/16" OD x 4-7/8"	1

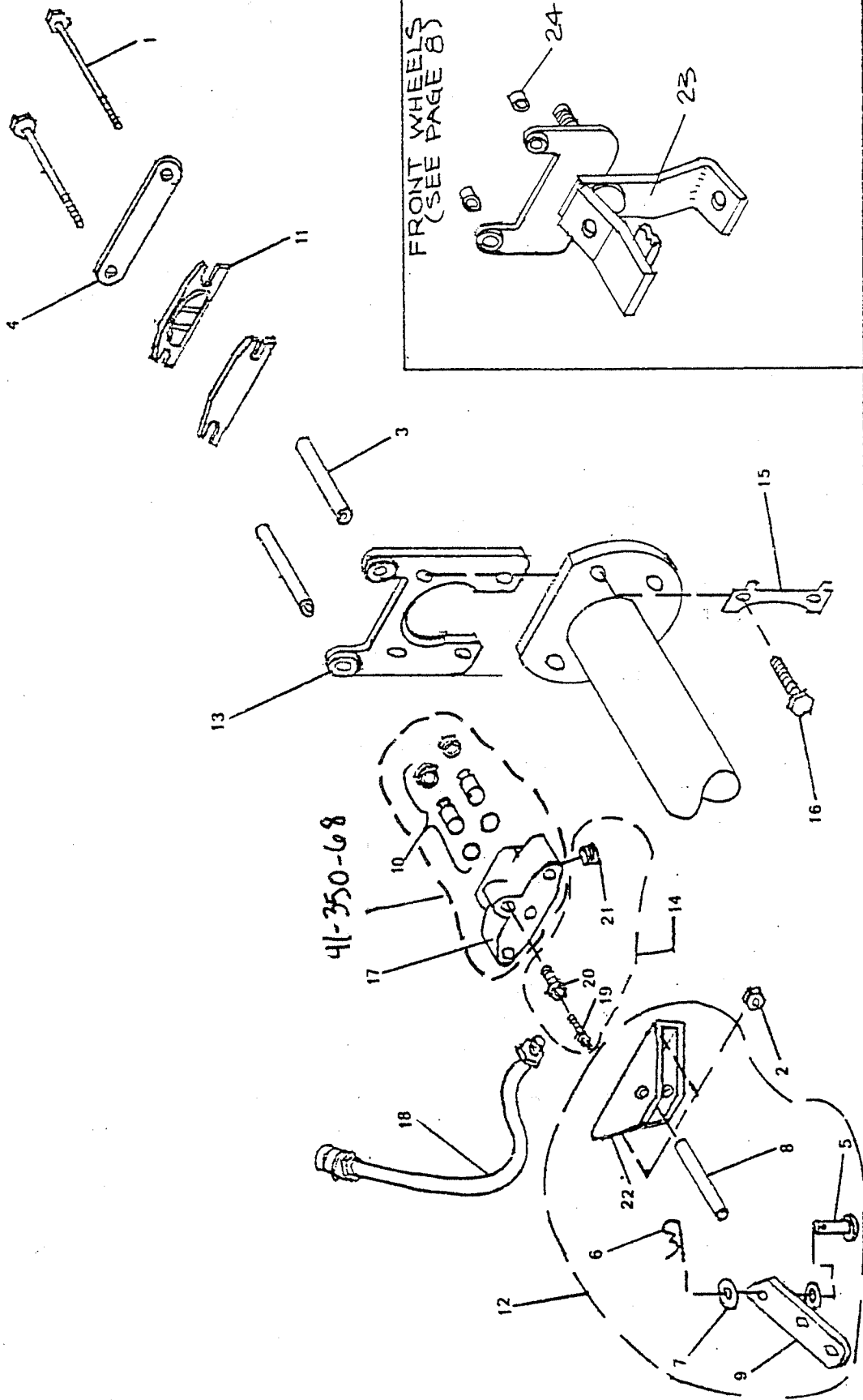

HYDRAULIC DISC BRAKES B2-10

HYDRAULIC DISC BRAKES
FIGURE NO. 8

FIG. I. D.	PART NO.	DESCRIPTION	QTY.
8-1	41-350-50	1/4 NC Hex Head Bolt, Gr. 8	4
8-2	41-348-58	Nut, Hex Lock, 1/4 NC HT	4
8-3	41-348-52	Spacer, Mech, Disc Brake	4
8-4	41-350-51	Plate, Secondary, Hydraulic Disc	2
8-5	41-350-52	Pin, Clevis, Hydraulic Disc Brake	2
8-6	41-348-56	Pin, Hitch, Mechanical Disc Brake	2
8-7	88-100-00	Washer, 11/32 ID x .110 Thick	4
8-8	41-350-54	Pin, Park Brake	2
8-9	41-350-53	Arm Park Brake	2
8-10	41-350-55	Kit, Cylinder Repair	4
8-11	41-348-70	Pad, Disc Brake	4
8-12	41-350-04	Hardware, Park Brake, Hydraulic Disc	2
8-13	41-350-03	Bracket, Hydraulic Disc Body Lg. Brg.	2
8-14	41-350-02	Fittings, Brake, Hydraulic Disc	2
8-15	41-350-05	Clip, 2 Hole W/Tab, Lg. Brg.	4
8-16	96-328-00	Bolt, 3/8 x 5/8 NC Spcl. Hd., Gr. 5	8
* 8-17	41-350-01 ⁸⁶	Brake, Hydraulic Disc Body	2
8-18	99-580-20 ⁸⁷	Hydraulic Hose	2
8-19	99-582-00	Screw, Bleeder	2
8-20	99- 852 -01 ⁵⁸⁸	Adapter, Threaded	2
8-21	41-886-00	Plug, Hex Socket	2
8-22	41-350-0 6 ¹²	Bracket, Lever	2

*ALSO INCLUDES THESE PARTS PER EACH BRAKE

8-1 (41-350-50)	Qty. 2	8-4 (41-350-51)	Qty. 1
8-2 (41-348-58)	Qty. 2	8-10 (41-350-55)	Qty. 1
8-3 (41-348-52)	Qty. 2	8-11 (41-350-56)	Qty. 2

FRONT HYDRAULIC DISC BRAKES (OPTIONAL)

8-23	14-210-88	Spindle, Weldment, Left (Reference Only)	
	14-210-89	Spindle, Weldment, Right (Reference Only)	
8-24	32-240-42	Brg., Plastic w/Metal Backing, 3/8	2

NOTE: FRONT HYDRAULIC DISC BRAKES DO NOT USE THESE PARTS
8-12, 8-13, 8-15, 8-16.

REPLACING BRAKE CYLINDER PARTS (CALIPER ASSEMBLY)

CAUTION: BLOCK VEHICLE WHEELS, PLACE FORWARD/REVERSE SWITCH IN NEUTRAL, TURN KEY TO OFF POSITION AND REMOVE FROM SWITCH. SET PARK BRAKE.

1. Remove wheel.
2. Disconnect park brake at park brake lever on caliper assembly. (Figure 1)
3. Disconnect Brake Line/hose at caliper, cap hose.
4. Bend down locking tabs on mounting bracket.
5. Remove mounting bolts.
6. Lift caliper assembly off vehicle.
7. It is only necessary to remove one bolt and spacer. (Figure 2)
8. Remove pads. (Figure 2)
9. Remove rubber boots.
10. Slide out pistons.

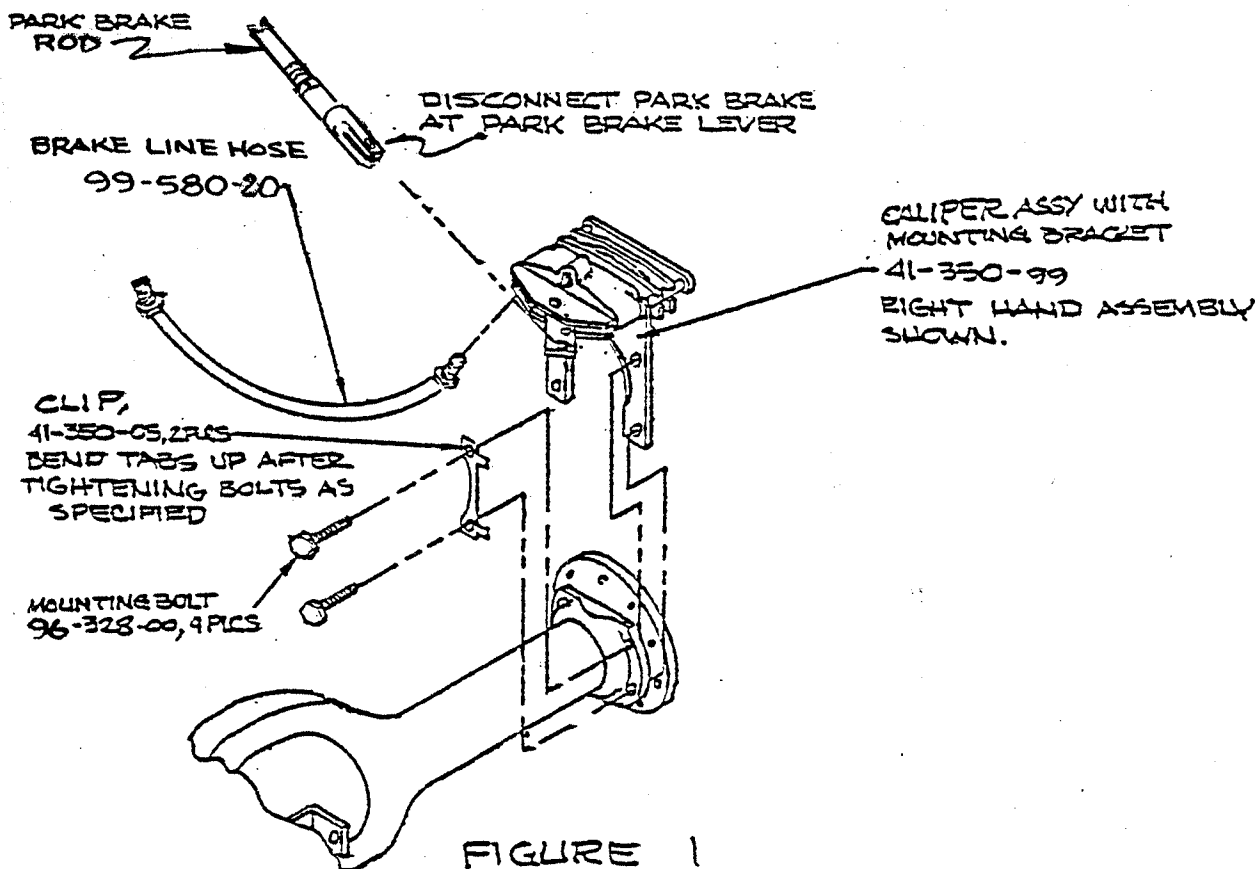

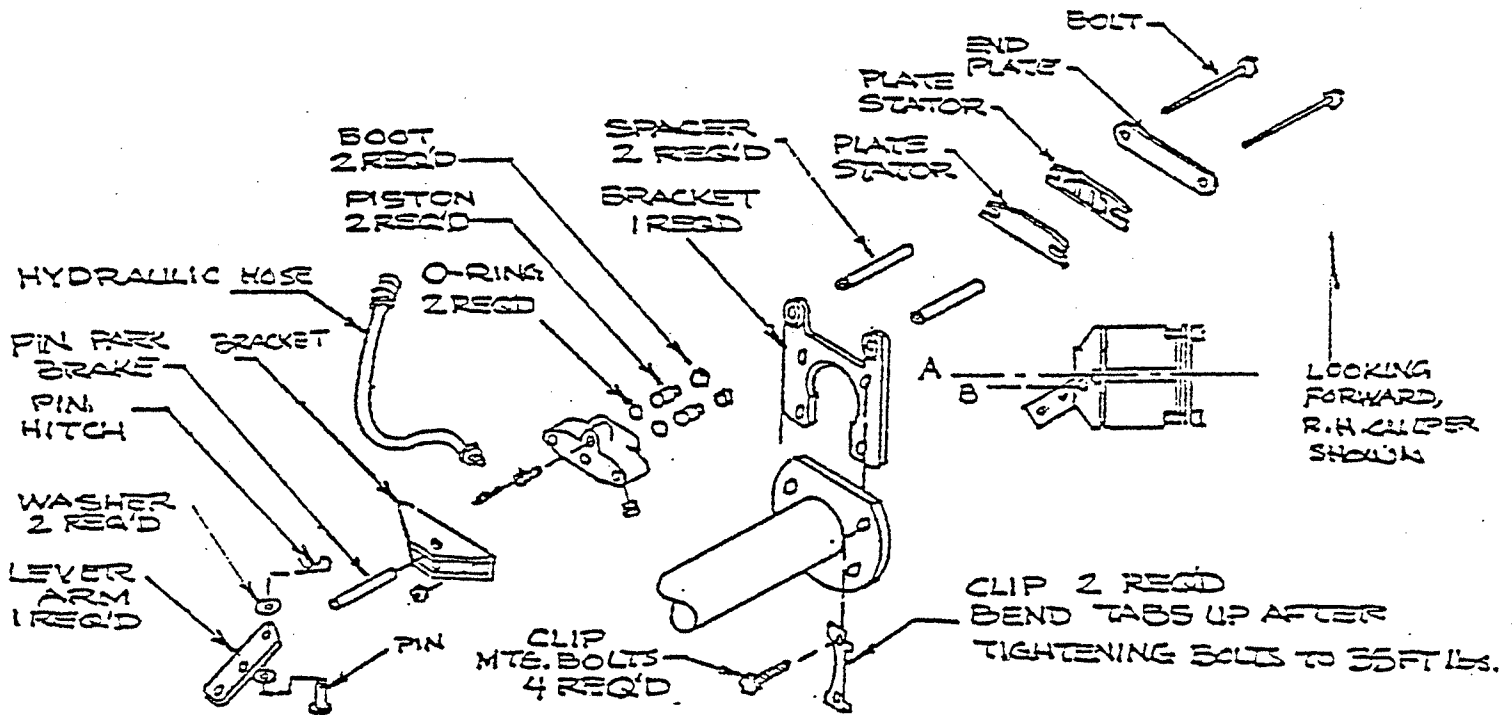

FIGURE 2

11. Examine caliper housing for wear, pitting, particularly in 'o' ring groove. If badly worn, replace housing.
12. Replace individual parts, piston, 'o' ring and boot as required.
13. Re-assemble, installing brake stator, spacer and bolt. Tighten bolts to 12 foot pounds.
14. Remount caliper assembly in vehicle with new clips. Tighten clip mount bolts to 30 foot pound, bend clip tabs up to prevent loosening. Note orientation of caliper center line 'A' to park brake lever 'B' center line. Be sure friction material is facing the disc.
15. Rotate disc to be sure there is running clearance. Contact between the pad and disc is common.
16. Re-connect hydraulic lines and park brake cable.
17. Bleed brake system and adjust park brake. Bleed air from brake system. See Section 12, page 2.

REPLACING BRAKE PADS (REFERENCE FIGURE 2)

NOTE: IT IS NOT NECESSARY TO DISCONNECT PARK BRAKE ROD TO REPLACE BRAKE PADS.

1. Examine caliper assembly for worn pads. If plates are close to disc and hydraulic pistons will be particularly extended then pad replacement is necessary.
2. Replace pads by retracting plate against pistons to allow for plate replacement. If pistons are difficult to retract, loosen bleeder valve, (allow fluid to escape) push plate and immediately re-tighten bleeder valve to avoid trapping air.
3. Remove one retainer bolt and spacer, remove both stator plates.
4. Replace both stator plates.
5. Re-install bolt and spacer, tighten to 12 foot pounds.
6. Re-install wheel (repeat all steps for opposite wheel otherwise brake system will not balance.
7. Bleed brakes. See Section 12, page 2
8. Adjust deadman brake. At Rods. See Section 12, page 5.

MOTOR MAINTENANCE, SERVICE AND ADJUSTMENT ELECTRIC MOTORS
REFER TO FIGURE ON PAGE 2

Detailed service procedures covering maintenance of bearing brushes and commutator are covered in this section. Do NOT PERFORM THIS PROCEDURE WHILE BATTERIES ARE BEING CHARGED.

Maintenance of electric motors should be referred to personnel with and equipment. Should it be necessary for you to order replacement parts for your motor, IT IS NECESSARY TO INCLUDE COMPLETE NAMEPLATE DATA WITH ORDER.

MOTOR MAINTENANCE - BRUSH INSPECTION AND REPLACEMENT

1. With new brushes, see note on G.E. drawing, page 2 section 13.
2. If brushes are worn, remove motor from vehicle and remove motor end bell for access to brushes. Install new brushes. Use fine sandpaper to 'seat in' new brushes to commutator. To verify when to replace worn brushes, proceed as follows:
 - a. For motors equipped with brushes having end pigtails and side hooks, replace brush when hook is within 1/16" from bottom of hook slot.
 - b. For motors equipped with brushes having side pigtails only, replace brush when pigtail is within 1/16" from bottom of pigtail slot.
- NOTE: When one brush is replaced in a motor, it is considered good maintenance practice to replace all brushes.
3. Check operation of each brush to assure that brush slides freely and does not bind in holder.
4. Replace motor end, reinstall in vehicle.

MOTOR DISASSEMBLY AND REASSEMBLY

1. Remove motor from vehicle as described in Section 11.
2. Determine if witness marks on end bell and stator housing are present. If not, mark end bell and housing to assure proper relation of brushes and commutator when reassembling.
3. Remove cover, exposing brush assemblies. Lift brushes from brush holder.
4. Remove bolts holding end bells and remove end bell and rotor. (Pull from shaft extension end). Take care not to damage any coils or armature wires when handling motor parts.
5. Press or pull old bearings off by using bearing press or bearing puller. Do not damage shaft while removing bearings.
6. Install new bearings onto shaft by gentle pressure or tapping with proper tool on inner race only. Bearing will be damaged if pressed or driven by outer race or seals.
7. If the commutator is worn or 'burned', it should be turned, the mica undercut and commutator polished.
8. Oil bearing housing lightly to aid in reassembly.
9. Reassemble motor taking care that all parts are kept clean.
10. Install brushes and 'seat in' with fine sandpaper.
11. Check operation of each brush to assure that brush slides freely in holder.
12. Replace end bell.
13. Reassemble to vehicle as described in preceding subsection.

NOTE: If motor terminal studs were removed for inspection, refer to Section 11 for correct procedure to avoid damaging studs.

ELECTRIC MOTORS continued
REFER TO FIGURE
SHOWN BELOW

NOTE: SEE PAGE 3 SECTION 13 FOR PARTS LIST

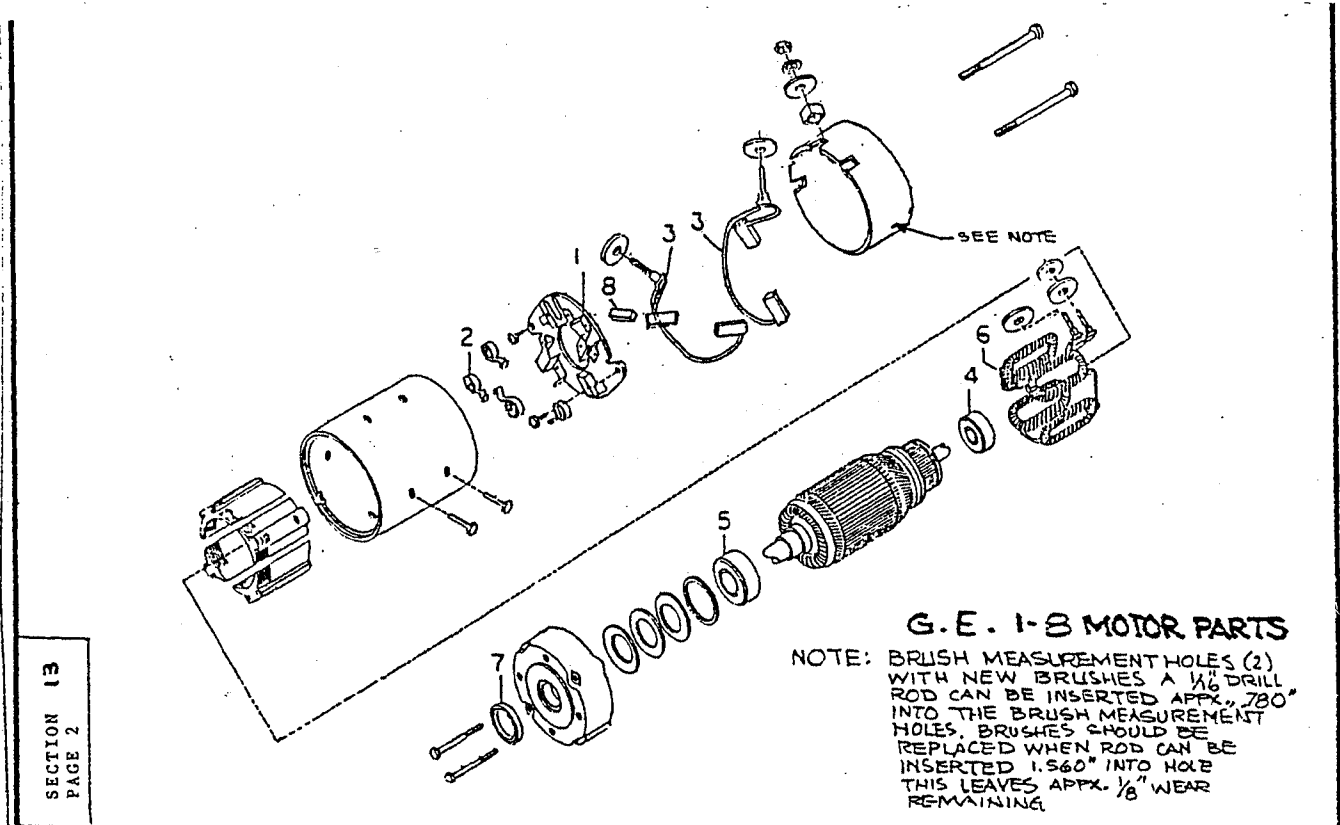
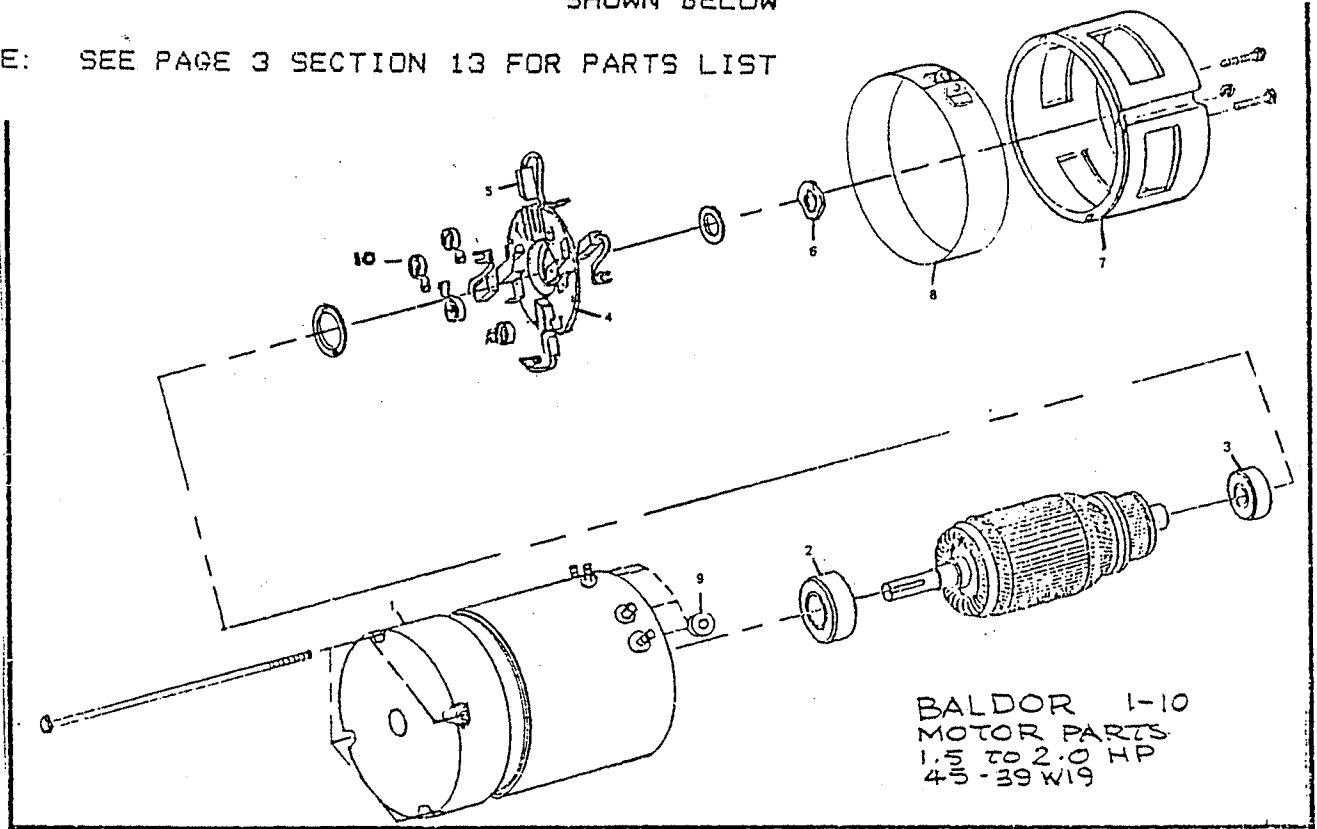

ELECTRIC MOTORS continued
REFER TO FIGURE PAGE 2

FIG. I.D. PART NO. DESCRIPTION QTY.
Replacement Parts for Baldor Motor (1.5 to 2.0 HP Motor) 35P161Z113 T-D
Part # 70-025-00.

B-1	70-617-11	End Plate, Pulley	1
B-2	80-504-00	Ball Bearing, Pulley End	1
B-3	80-202-00	Ball Bearing, Commutator End	1
B-4	70-181-50	Brush Holder, Mounting Assembly	1
B-5	70-121-10	Brush Motor	4
B-6	97-126-00	Washer, Wavytion Cover	1
B-7	70-617-00	End Plate, Front	1
B-8	30-804-00	Cover, Brush Inspection	1
B-9	70-210-60	Insulator, Studs	4
B-10	85-408-00	Spring, Brush Torsion, Orange	4

STANDARD ON B 2-10

Replacement Parts for G.E. Motor 5BC48JB754 (1.5 to 2.0 H.P. Motor)
Taylor-Dunn P/N 70-049-00

GE-1	70-172-00	Brush Holder (without brushes)	1
GE-2	85-412-00	Spring, Brush Extension	4
GE-3	70-104-00	Brush Assembly	2
GE-4	80-200-00	Ball Bearing, Commutator	1
GE-5	80-504-00	Ball Bearing, Pulley End	1
GE-6	70-205-00	Field Coil Set	1
GE-7	45-506-00	Oil Seal	1
GE-8	70-250-00	Gasket, Terminal	4

10 HP OPTION WITH PT 350

Replacement parts for G.E. Motor 5BCJB399 (3.5 H.P) develops 12 H.P.

GE-1	70-188-00	Brush Holder (without brushes)	1
GE-2	85-412-00	Spring, Flat Torsion with Curved End	4
GE-3	70-105-00	Brush Assembly	4
GE-4	80-200-00	Ball Bearing, Commutator	1
GE-5	80-504-00	Ball Bearing, Pulley End	1
GE-6	70-203-10	Field Coil Set (4 coils)	1
GE-7	45-507-00	Oil Seal	1
GE-8	70-210-62	Gasket, Terminal	4

INTRODUCTION

This section has been prepared for the purpose of familiarizing the owner with the operational features of the Taylor-Dunn PWR-TRON solid state speed controls. The PWR-TRON 240 and 350 are developed and available only from Taylor-Dunn and are warranted for one full year. Modifications to the control unit, drive or power system will void the warranty.

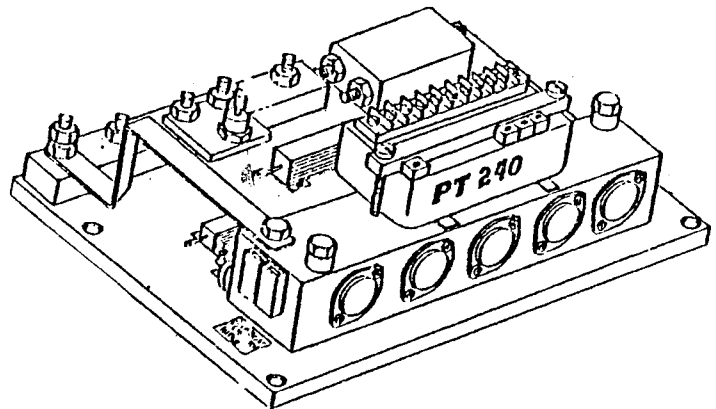

24 OR 36 VOLTS
RECOMMENDED FOR
USE UP TO 6 H.P.
MOTORS
(INTERMITTENT)

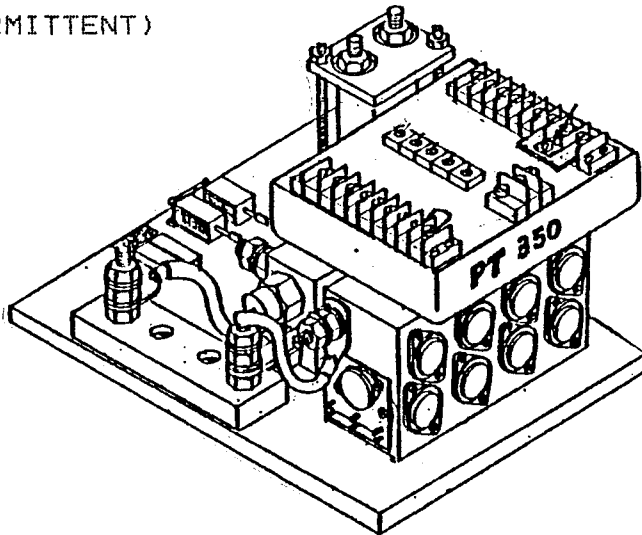

24 OR 36 VOLTS
RECOMMENDED FOR
USE UP TO 10
H. P. MOTORS
(INTERMITTENT)

THE PT 240 IS STANDARD FOR B 2-10 VEHICLES

PWR-TRON 240/350

GENERAL

The PWR-TRON unit is readily accessible when the deckboard is raised. The PWR-TRON unit performs two functions; forward-reverse and acceleration via mechanical linkage to the foot pedal. You will notice the PWR-TRON unit is a transistorized supply that regulates the voltage fed from the battery through the accelerator module to provide the necessary signal to the motor. This gives the operator full control of the vehicle at all speeds and braking under all conditions.

FEATURES

Some of the inherent advantages over conventional (resistor type) speed controls are:

1. Increased range; 30% (mileage may vary).
2. Positive current limit; increases motor and battery life.
3. No maintenance to PWR-TRON required.
4. Power matched to motor; providing maximum power output during towing or hauling.
5. Thermal protection to prevent over heating and damage to PWR-TRON.
6. Unit is protected from incorrect battery hookup.
7. "Low" battery protection through solenoid drop out.
8. "Built-in" motor short protection; prevents run away currents and high temperatures, should a motor short occur.
9. Controlled acceleration for smooth starting; no more jack rabbit starts.
10. Direction reversal protection; while accelerator is fully depressed, reverse direction switch, vehicle will automatically slow down, then accelerate in reversed direction. Note, by letting up on the accelerator then re-accelerating, a smoother control will be achieved.
11. Modular construction provides simplicity in trouble shooting, parts replacement and servicing in the field.
12. Each unit has a thermocouple that shuts off power at 160 degrees F which is the operational limit of the PWR-TRON. The unit automatically resets when it has cooled to approximately 130 degrees F.

PWR-TRON 240/350

CIRCUITS AND OPERATION

There are two circuits included in the operation of the PWR-TRON, the control circuit and the power circuit.

The control circuit (light gauge wire) includes key switch, micro-switch, MS-1, potentiometer; R1, activated by the accelerator arm on back of accelerator module, the PWR-TRON solid state controller, forward reverse switch and solenoid panel.

The power circuit (heavy gauge wire) includes the batteries, forward/reverse solenoids and motor.

The two circuits operate as follows: (refer to Fig.1)

CONTROL CIRCUIT (see Fig. 2)

Forward operation. Turn key switch to "ON" position and forward-reverse switch to forward position, MS-1 is closed providing a current path to the forward solenoid coil and closing forward contact on the forward-reverse switch. As the accelerator is depressed, the potentiometer, R1, will increase the current, moving the vehicle forward.

Reverse operation. Turn key switch to "ON" position and forward-reverse switch to reverse position, MS-1 is closed providing a current path to the reverse solenoid coil and closing the reverse contact on the forward-reverse switch. As the accelerator is depressed, the potentiometer, R1, will increase the voltage, moving the vehicle in reverse.

POWER CIRCUIT (see Fig. 3)

Forward operation . When the control circuit is energized and the solenoid contacts are closed, the current flow is then channeled through the PWR-TRON and then to the power wiring. Motor speed is controlled by voltage output from the PWR-TRON. The PWR-TRON is varied by the potentiometer, R1, in the control circuit.

Reverse operation. The same circuit is used as forward operation except the forward-reverse switch is moved to reverse current flow through the motor.

OPERATING YOUR PWR-TRON EQUIPPED VEHICLE

To put your vehicle into operation, sit on seat, and turn ignition key to "ON". Select direction you wish to travel by moving forward/reverse switch to desired position. Release parking brake, slowly depress accelerator pedal until vehicle is moving at desired speed.

You will notice your vehicle has a smooth transition from start to high speed operation. This is a built-in characteristic of the PWR-TRON speed control, avoiding "jack-rabbit" starts.

"Plug braking" is an additional feature of the PWR-TRON. It is not necessary to come to a complete stop before reversing the vehicle. It is only necessary to reverse the vehicle while it is in motion and accelerator is fully depressed. The vehicle will automatically slow to a stop and reverse itself to full acceleration. " Plug braking" should be done in an obstruction free area until the operator gets the feel for this maneuver. This maneuver does not damage the PWR-TRON. It is installed to relieve strain on the drive system. Braking of vehicle is best performed with foot brake. It is recommended when starting the vehicle to be sure to always turn ignition key on first then select direction of travel with the forward/reverse switch, before depressing the accelerator pedal.

PWR-TRON PREVENTIVE MAINTENANCE

WARNING

BEFORE WORKING ON THE PWR-TRON UNITS OR ANY PART OF THE VEHICLE ELECTRICAL SYSTEM, DISCONNECT BOTH THE MAIN POSITIVE AND NEGATIVE BATTERY LEADS. PLACE THE FORWARD/REVERSE LEVER IN NEUTRAL, TURN OFF AND REMOVE. ALWAYS SET PARKING BRAKE (SEAT UP).

No regular maintenance is required.

Be sure ignition key is on before depressing accelerator pedal. DO NOT depress pedal then turn on key. This is unsafe operation.

CAUTION

Do not steam clean or spray with water.

Make sure all wire connections are secure.

There are three modules as part of this system, solenoid panel, accelerator module and PWR-TRON module. These are all easily removable for replacement and service.

Only qualified service personnel should perform any replacement, adjustments or servicing of the PWR-TRON module, solenoid panel or the accelerator module. This will avoid the possibility of voiding your warranty on the PWR-TRON 240 or 350.

When returning vehicle to pre-service configuration make certain batteries are properly connected to avoid damage.

*** The PWR-TRON control is covered by a one year warranty. Taylor-Dunn offers a control exchange program which we highly recommend. Under the program, Taylor-Dunn will exchange units and perform the more difficult repairs at its facility.

PWR-TRON TROUBLE SHOOTING STEPS

<u>SYMPTOM</u>	<u>PROBABLE CAUSE</u>	<u>CORRECTIVE ACTION</u>
1. Car stops running.	1. Overheated.	1. Allow to cool, up to 15 minutes before restarting. CONSULT TAYLOR-DUNN
2. Car stops running	2. Batteries too low drops out solenoid and/or controller.	2. Check batteries re-charge or replace as necessary. <u>CAUTION:</u> Make certain batteries are properly connected
3. Car goes forward but not reverse (or vice versa).	3. A. Without whining - Forward or reverse solenoid failure. B. With whining C. Fails after changing direction	3. A. Replace respective solenoid. NOTE: Whining is normal during starting, caused by motor. A click before moving is normal, solenoid turning on. B. Motor improperly connected, check wiring diagrams. C. Pot B (plugging) set too low. Turn up 1/8 turn.

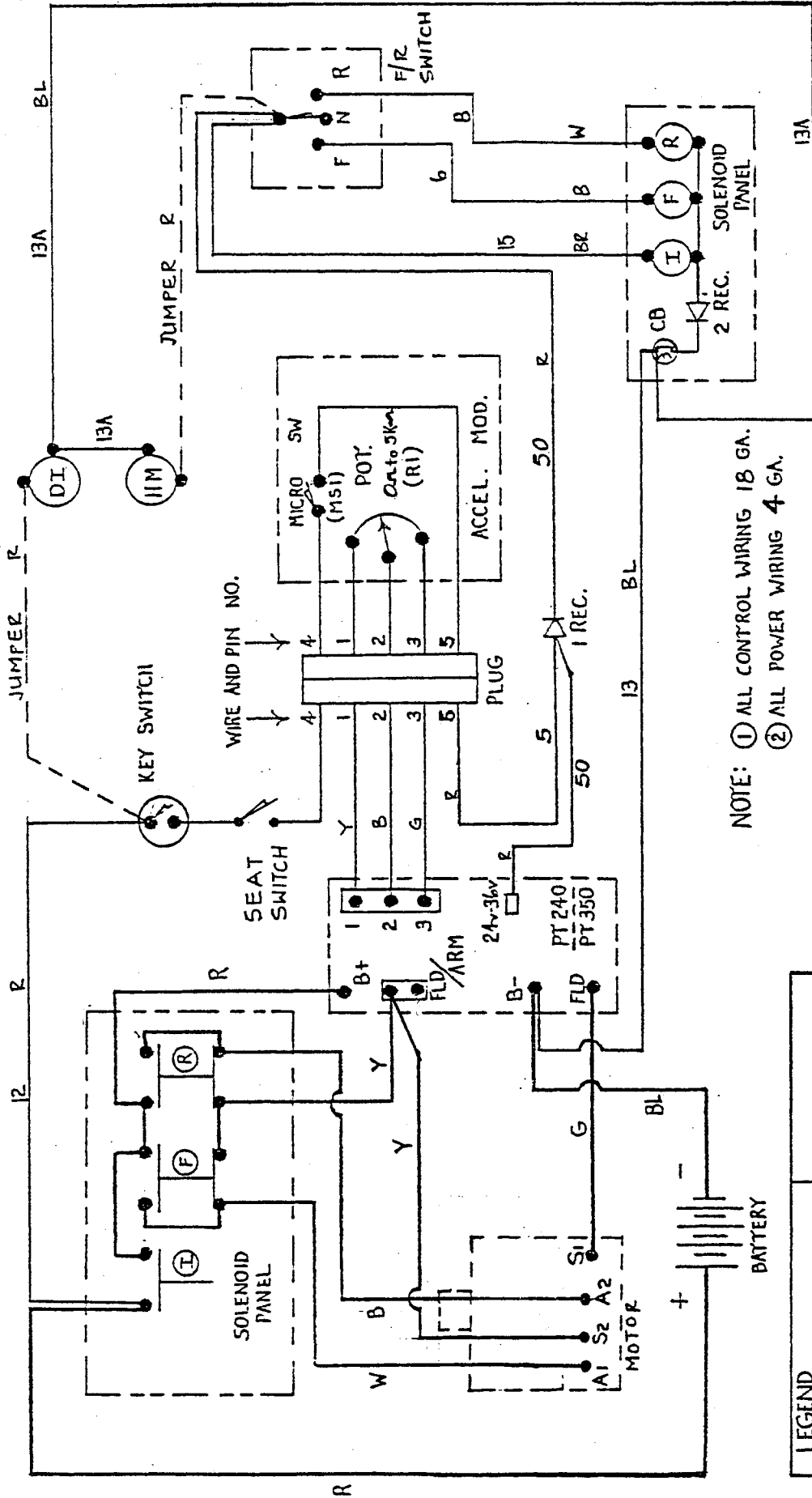

NOTE: ① ALL CONTROL WIRING 18 GA.
② ALL POWER WIRING 4 GA.

PWR-TRON 240/350 COMBINED CIRCUIT
DIAGRAM WIRING SCHEMATIC. FIGURE 1.

CHG 4-19-85 JPB

LEGEND	Y	B	W	G	BL	R	BR
REC	YELLOW	BLUE	WHITE	GREEN	BLACK	RED	BROWN
DI	DISCHARGE INDICATOR						
HM	HOUR METER						
DI	DISCHARGE INDICATOR						
CB	CIRCUIT BREAKER						
I	ISOLATOR						
F	FORWARD						
R	REVERSE						

LEGEND

B+	BATTERY POS.	R	RED
B-	BATTERY NEG.	BL	BLACK
FLD	FIELD	B	BLUE
ARM	ARMATURE	Y	YELLOW
I	ISOLATOR	G	GREEN
F	FORWARD	W	WHITE
R	REVERSE		

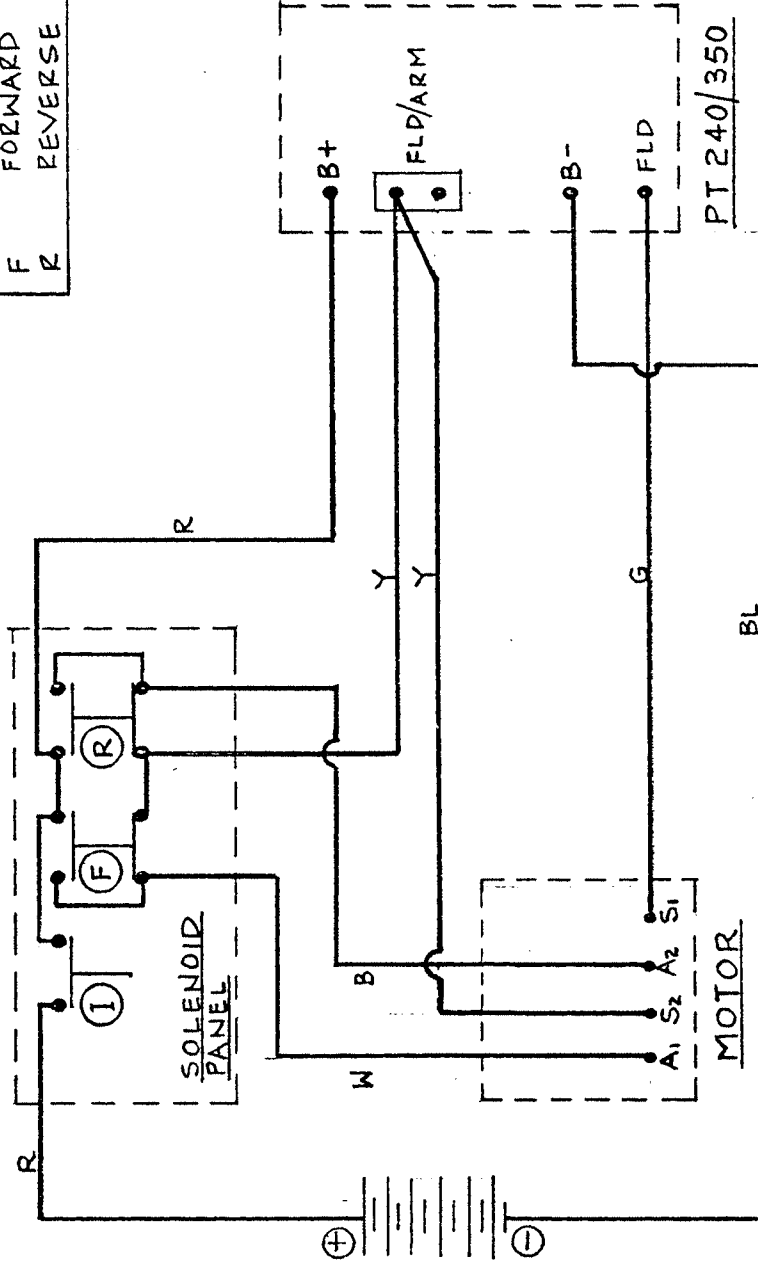

PWR-TRON 240/350 POWER SCHEMATIC FIG 3

POWER HARNESS 75-141-21

CHG 4-19-85 JTB

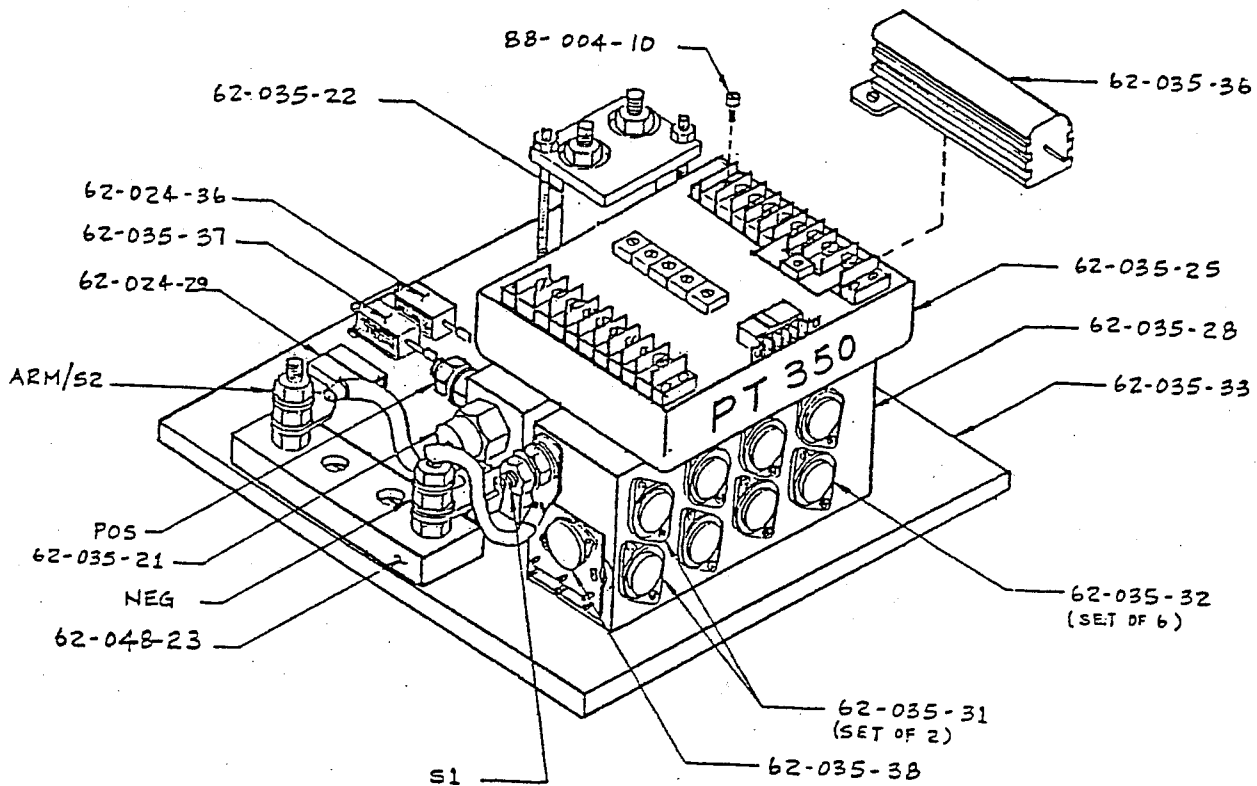

PWR-TRON 350 SPEED CONTROLLER, 24/36 VOLTS

PART NO.	PT350 DESCRIPTION	QTY.
62-035-21	Diode, Flywheel	1
62-035-21	Diode, Plugging	1
62-035-22	Capacitor	1
62-035-25	Logic Unit	1
62-035-28	Block, Transistor	1
62-035-33	Base Plate	1
62-035-32	Transistors, Power (set)	6
62-035-31	Transistors, Driver (set)	2
62-035-38	Transistor Assembly, Driver, Driver	1
62-048-23	Block Terminal	1
62-024-29	Key Switch	1
62-024-36	Resistor, 10 W 70 OHM	1
62-035-36	Resistor, 50 W .5 OHM	1
62-035-37	Resistor, 10 W 18 OHM	1
96-340-20	Stud, Brass 4MM X 5-1/2	2
88-004-82	Nut, 4MM, 88-068-67 Washer	2 each
88-004-10	Screw, 3 MM X 5/16	21
88-025-04	Screw, 3 MM X 1/2	25
62-035-10	Cover	1

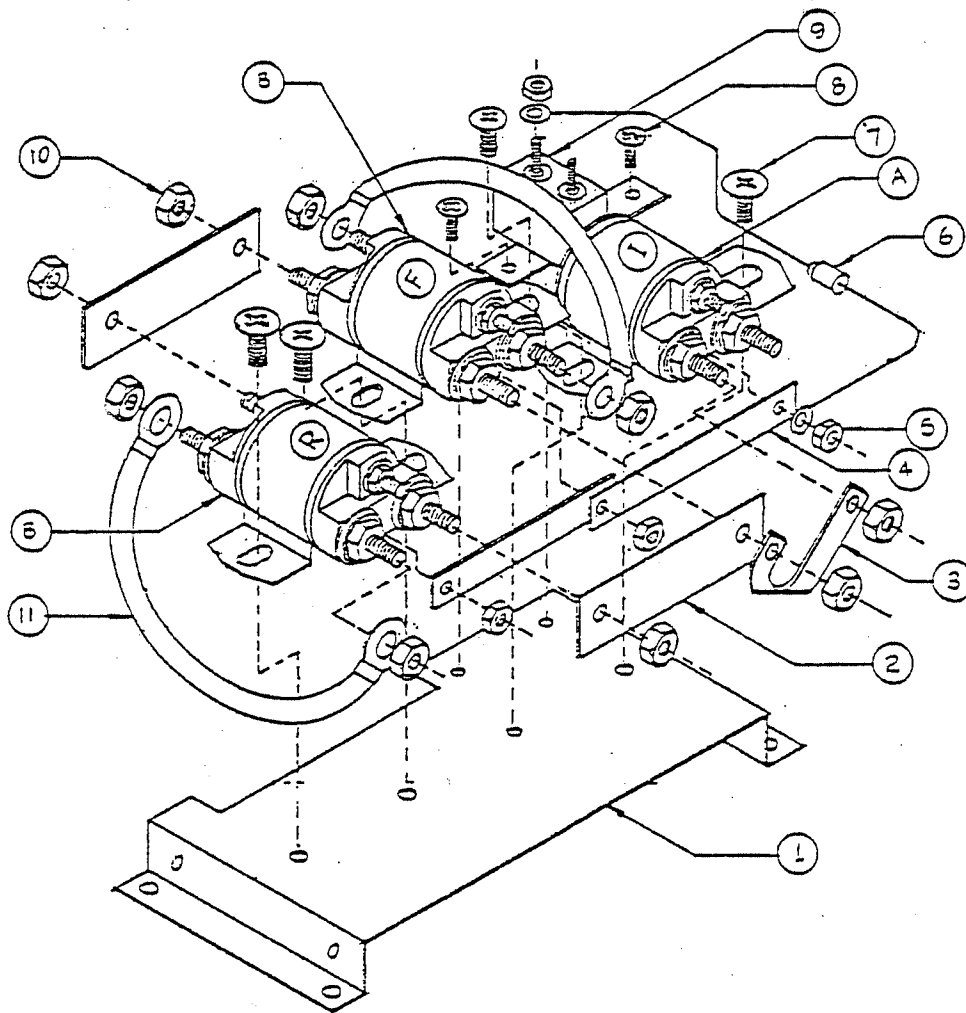

SOLENOID ASSEMBLY
MODEL B 2-10

72-560-00, 24V PANEL ASS'Y I 72-560-10, 36V PANEL ASS'Y
 A 72-501-24 SOLENOID, SPST24V (1) | A 72-501-36 SOLENOID SPST36V (1)
 B 72-501-25 SOLENOID, SPST24V (2) | B 72-501-37 SOLENOID SPST36V (2)

FIG NO.	PART NO.	DESCRIPTION	QTY.
1.	72-560-50	Panel, Solenoid Mtg.	1
2.	62-838-51	Bar, Buss 2 x 5/8 CU	2
3.	61-838-20	Buss, Curved	1
4.	61-838-50	Bar, Buss 3 x 3/8 CU	2
5.	88-048-62	Nut	4
6.	75-224-10	Jumper, 5-1/4 In., 18 GA. W/Diode	1
7.	88-838-06	Screw, #14 x 1/2 Pan Head Sheet Metal	4
8.	88-818-06	Screw, #8 x 1/2 Pan Head Sheet Metal	2
9.	79-840-00	Circuit Breaker, 10 AMP	1
10.	88-089-91	Nut, Hex Jam, 5/16 NC, Thin	9
11.	75-235-20	Jumper, Red, 4-1/4, 4 GA	2
	72-560-51	Cover, Solenoid Panel (not Shown)	1

ACCELERATOR MODULES
PT240/350

GENERAL FEATURES

All accelerator modules parts list are identical for all vehicles except for the accelerator arm length. This difference is noted on the following drawings and parts list. The orientation of the accelerator are is shown mounted in the "OFF" position for all vehicles. All parts lists figures are identified in order of assembly. Whenever a re-assembly is necessary a potentiometer check is required before adding pulleys and belts.

MICRO-SWITCH CHECK

Using a VOM, with micro-switch in "ON" position. Red wires should read Zero OHMS and OFF position will read infinity.

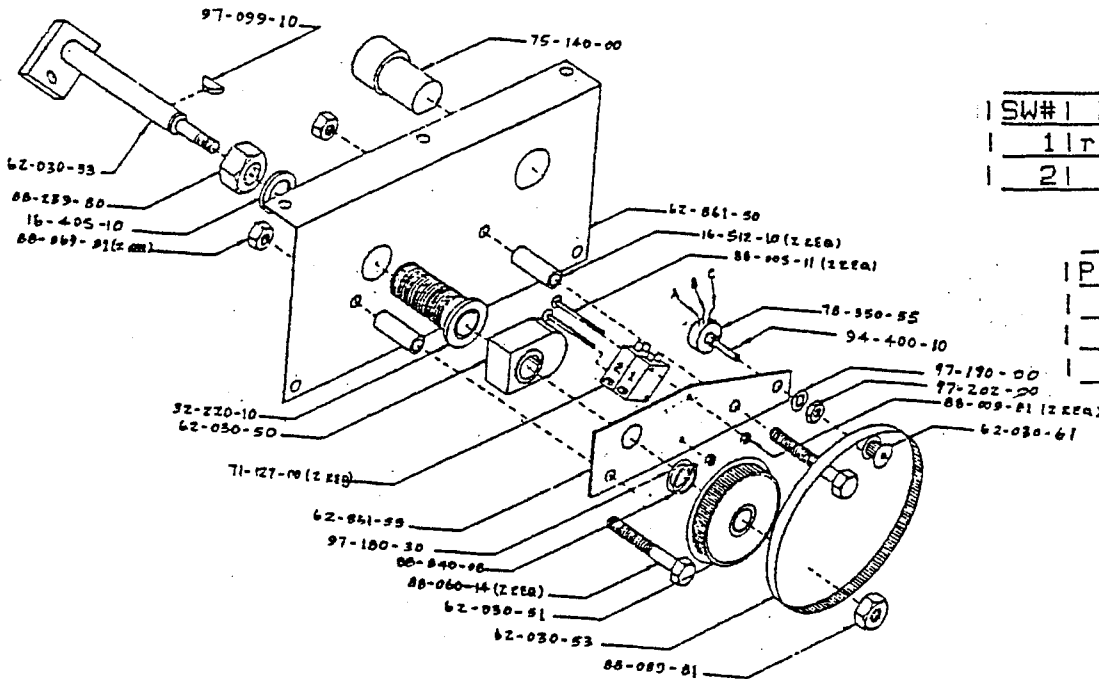

MICRO SWITCH
WIRE DIAGRAM

SW#	NO	NC	COM
1	red#5		red #4
2		blue#7	blue#6

POT WIRE DIA.

POT PIN	WIRE #
A	Green #3
B	Black #2
C	Yellow #1

ACCELERATOR MODULE (COVER NOT SHOWN) 62-030-13
MODEL B 2-10

FIG NO.	PART NO.	DESCRIPTION	QTY.
1	62-861-55	Plate, Pot. Mtg. Accel Module	1
2	71-127-00	Switch, Micro	2
3	88-005-11	Screw, 4-40 x 1-1/4 Truss Hd.	2
4	78-350-55	Potentiometer	1
5	97-190-00	Washer Potentiometer	1
6	97-202-00	Nut, Potentiometer	1
7	88-009-81	Washer, 4-40 Lock	2
8	62-030-61	Sprocket 18T .0800	1
9	32-220-10	Bushing, Sw 1/2 ID, Brass	1
10	62-030-33	Rotor, Accelerator Module (B 2-10)	1
11	97-099-10	Key, Woodruff	1
12	88-239-80	Nut, 3/4 NF Hex Head Nut	1
13	16-405-10	Washer, 3/4 Lock	1
14	62-861-50	Plate, Backing, Accelerator Module	1
15	62-030-50	Cam, Micro Switch 1 In. Rad.	1
16	16-512-10	Spacer, 1/4 ID x 29/32 St. Tubing	2
17	88-060-14	Screw, 1/4 x 1-1/2	2
18	88-069-81	Nut, 1/4 Lock	2
19	75-140-00	Harness, Accelerator Module	1
20	97-180-30	Washer, 1/2 In. ID x 1/32 Thk.	1
21	88-840-08	Ring, Snap 1/2 Ext. Fleet Pk.	1
22	62-030-51	Sprocket, 80T .0800	1
23	62-030-53	Belt, .0800 12 In. 150 T	1
24	88-089-81	Nut, 5/16 NC, Lock	1
	62-030-58	Cover (not Shown)	1
	94-400-10	Glue, Loctite (Sprocket to Pot Shaft)	1

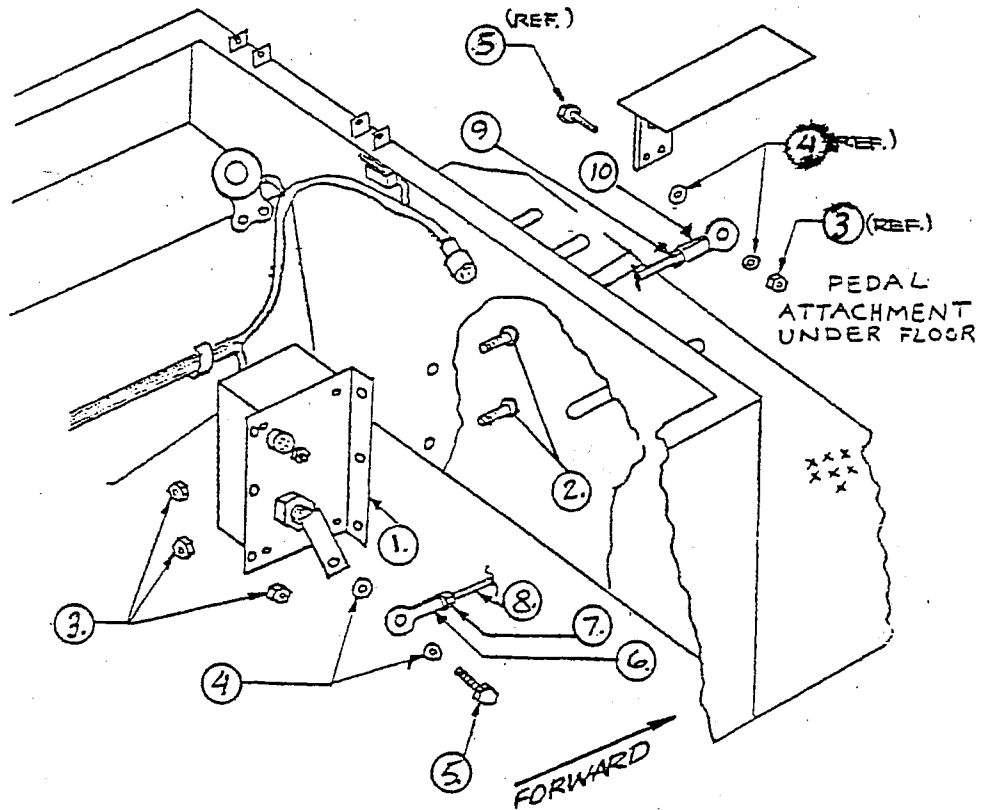

B 2-10 ACCELERATOR MODULE ASSEMBLY WITH ACCELERATOR LINKAGE

FIG. NO.	PART NO.	DESCRIPTION	QTY. REQ.
1	62-030-03	Module Accelerator	1
2	88-065-08	Screw, Truss Hd. Mach. 1/4 In. x 5/8 In. NC	2
3	88-069-81	Locknut, 1/4 In. NC	4
4	88-068-61	Washer, 1/4 In. SAE	4
5	88-060-09	Screw, 1/4 In. x 3/4 In. Hex Hd. Cap	2
6	86-503-98	Rod-End 1/4 -28 LH	1
7	97-211-00	Nut 1/4 -28 Hex LH	1
8	50-002-12	Rod, Control 1/4 -28 x 10-3/4	1
9	88-079-80	Nut 1/4 -28 RH	1
10	86-503-99	Rod-End 1/4 -28 RH	1

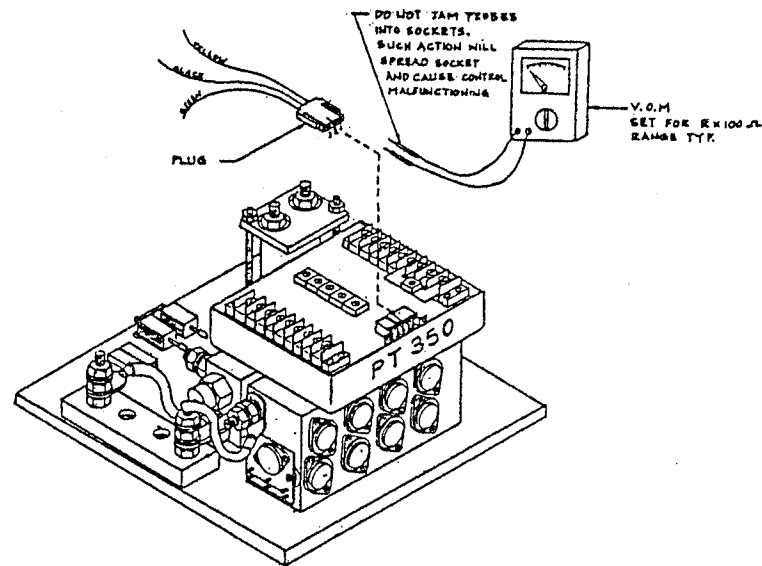
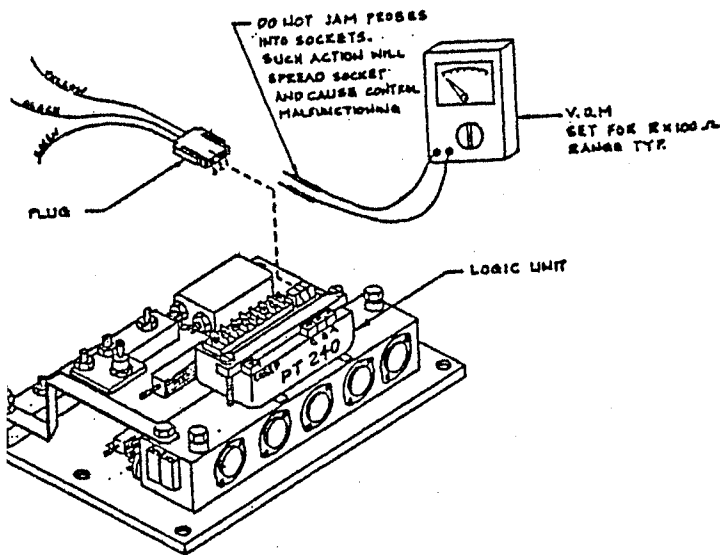

PWR-TRON 240/350 24/36 VOLTS

POTENTIOMETER CHECK & ACCELERATOR LINKAGE ADJUSTMENT

1. Disconnect plug (with yellow, black and green wires) at PWR-TRON logic.
2. Read 4K-5K ohm on V.O.M. between sockets 1 and 2 (yellow and black wires) with accelerator pedal in off position.
3. With accelerator pedal fully depressed, read 0 - 300 ohm on V.O.M. between sockets 1 and 2 (yellow and black wires). Adjust the accelerator pedal stop and/or accelerator linkage to achieve the above readings.
* DO NOT rely on the return stop inside the accelerator module. It is only a safety feature, not designed for constant foot pedal return pounding.
4. Reconnect plug to PWR-TRON 240 or PWR-TRON 350 logic unit.

CONTINUITY AND POWER CHECK

NOTE: VEHICLE DRIVE WHEELS MUST BE JACKED UP OFF FLOOR FOR FOLLOWING TEST.

CAUTION: THIS IS A FACTORY CHECKOUT PROCEDURE AND SHOULD ONLY BE MADE BY A QUALIFIED MECHANIC.

After the PWR-TRON system has been installed, a preliminary power check is required, prior to fine tuning of the PWR-TRON. The vehicle should be ready for basic operation at this time.

Lift green lead at S1 (refer to combined circuit diagram) and place a light, 36V in series with S1 and field pole on PWR-TRON. Place forward/reverse switch in forward. Initiate accelerator slowly, light should come up to maximum brilliance at full acceleration. Repeat same step for reverse. If problems are encountered, see "Trouble Shooting" section. (Caution, do not perform plugging with light attached.

When both steps are completed satisfactorily, place vehicle on floor, prepared for operation and fine tuning of the PWR-TRON unit. Proceed with trimpot adjustment on page 18 or 19.

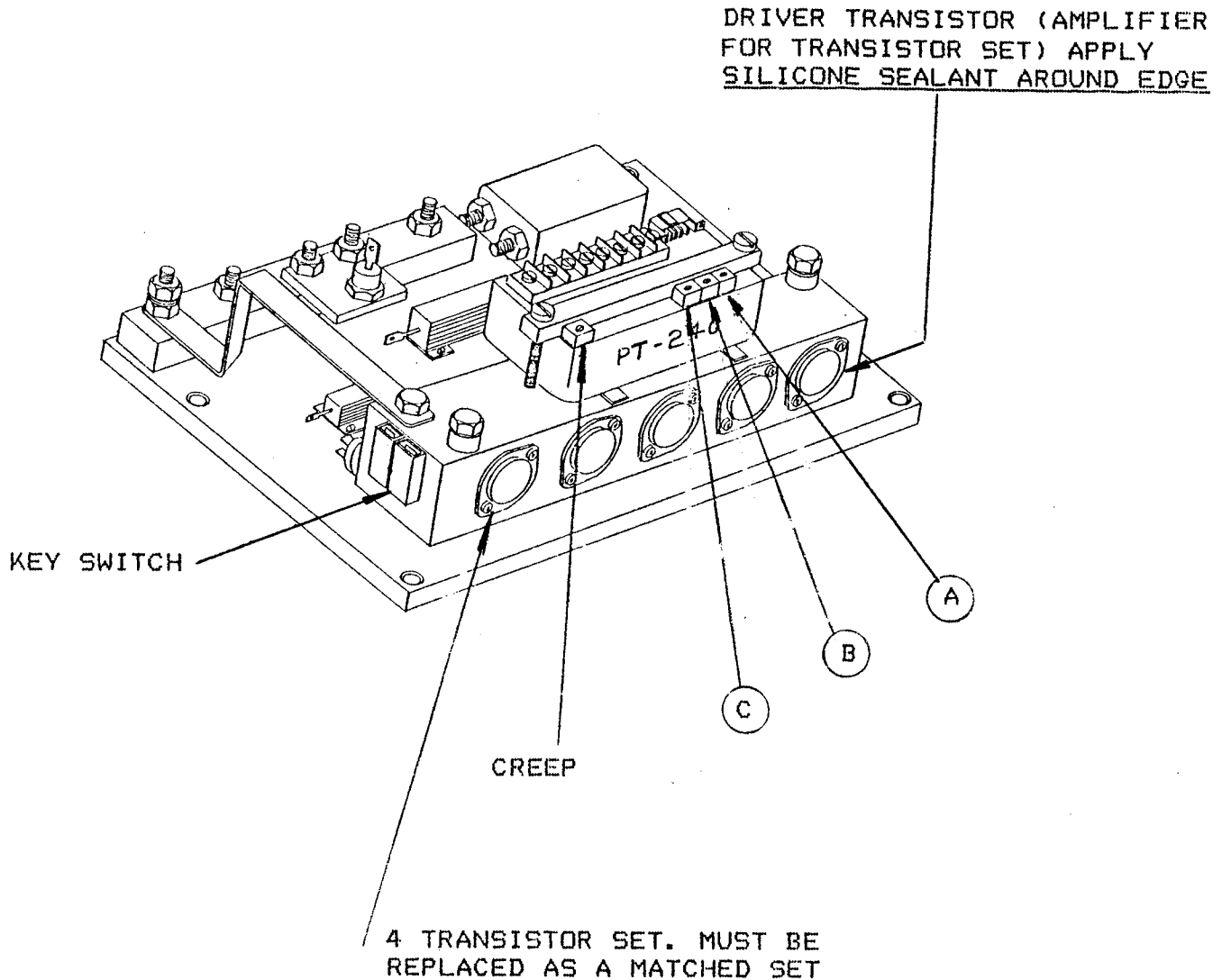

PWR-TRON 240 TRIMPOT ADJUSTMENTS

PERFORM ALL TRIMPOT ADJUSTMENTS IN ORDER SHOWN

CREEP - Adjust trimpot so motor whines but does not turn when accelerator switch is first closed.

- A. ACCELERATOR - Turn full direction of arrow
- B. PLUGGING - Turn full opposite direction of arrow to start. Turn up 1/8 in direction of arrow
- C. CURRENT LIMITER - Turn full direction of arrow.

AFTER ALL POTS HAVE BEEN FINAL ADJUSTED, COAT POTS WITH WHITE SILICONE SEALANT.

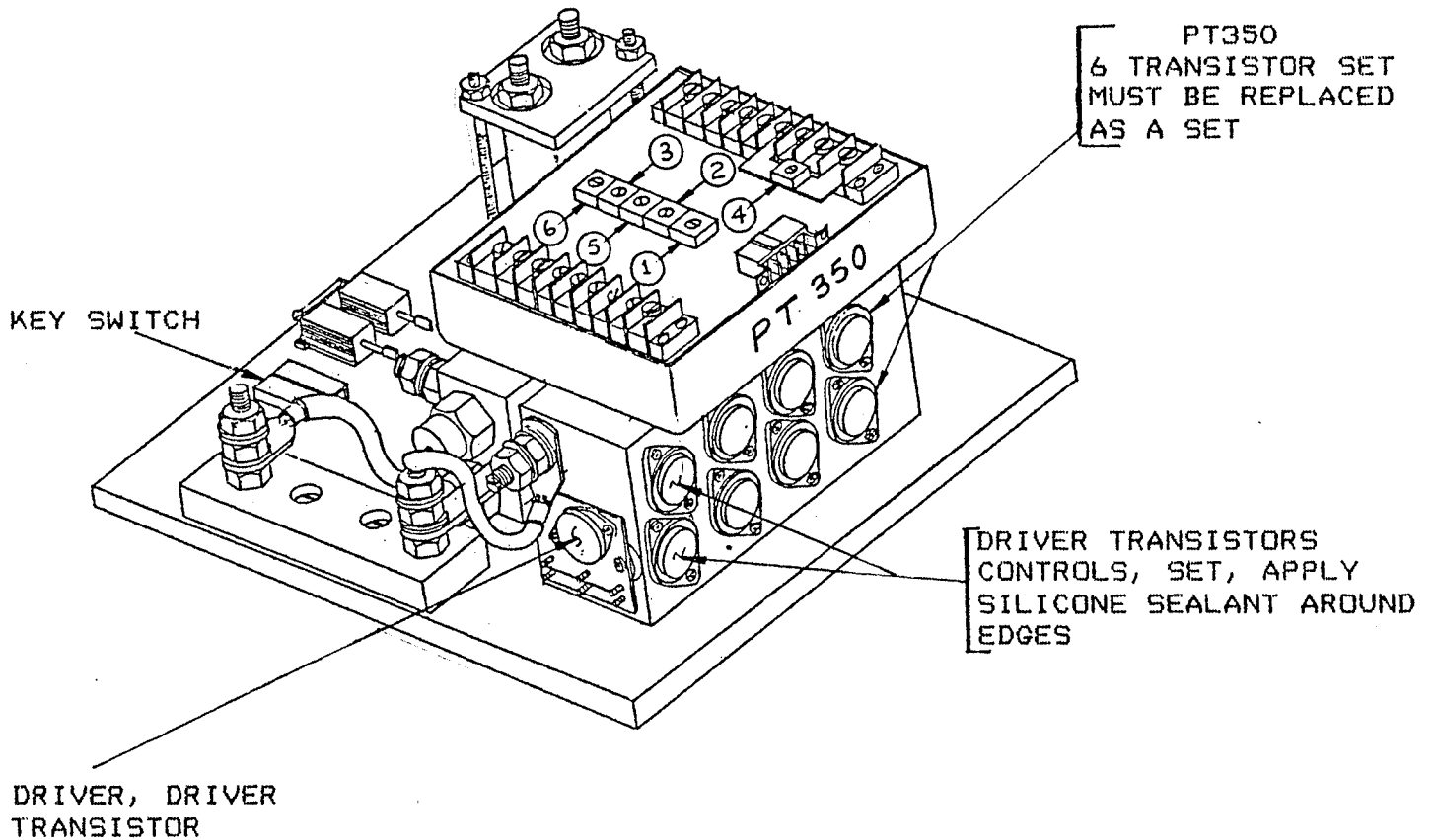

PT 350 TRIMPOT ADJUSTMENTS

Perform all trimpot adjustments in the same order shown. All braking is done last.

1. VOLTS ADJ. - Adjust trimpot so motor whines but does not turn when accelerator switch is first closed.
2. CURRENT LIMITER - Turn full direction of arrow.
3. ACCELERATOR - Turn full direction of arrow.
4. MAX BRAKE - Turn full opposite direction of arrow.
5. BRAKE - Turn full opposite direction of arrow to start. Turn up 1/8 in direction of arrow.
6. LOW SPEED MAX - Option feature, no adjustment required.

AFTER ALL POTS HAVE BEEN ADJUSTED, COAT POTS WITH WHITE SILICONE SEALANT.

PWR-PLUS (USED WITH PT 240)
FIELD KIT 62-025-60

INTRODUCTION

PURPOSE:

To provide direct battery connection to motor with no current limit allowing high current for tough applications. System consists of a logic, sealed high current solenoid, diodes, fuse, covers and wires.

LOGIC:

The seales unit is not field serviceable and must be replaced as a unit, should failure occur. The PWR-PLUS logic performs the following functions:

1. Checks for severely discharged battery.
2. Checks for pedal up before initial direction selection (to prevent lurching start).
3. Checks for shorted controller and/or by-pass solenoid welded shut (disables isolator if faulty).
4. Enables isolator solenoid if 1 & 2 & 3 are good.
5. Enables by-pass if accelerator fully depressed to close microswitch (initial 2 second delay for acceleration).
6. Disables by-pass during plug braking.

DIODES:

Provide path for high voltage, caused by solenoids when turned off. Must be installed to protect logic from voltage spikes.

SOLENOID:

High current sealed unit designed to carry stall currents of motor.

INSTRUCTIONS FOR PWR-PLUS
KIT 62-025-60

T-D PART NO.	DESCRIPTION	QTY.
62-025-00	Assembly, Panel, PWR-PLUS, 36 Volt	1
72-560-51	Cover, Solenoid Panel	1
75-170-00	Harness, Wire, PWR-PLUS	1
78-001-00	Fuse, 300 AMP	1
62-025-05	Strap, Fuse Mounting	1
88-049-80	10-32 Hex Nut	2
88-048-62	#10 Lock Washer	2
88-060-11	1/4 x 1 NC Bolt	4
88-069-81	1/4 Locknut	4
88-069-87	1/4 Fastite	4
88-088-63	5/16 Internal Tooth Lock Washer	2
88-099-91	5/16 NF Thin Pattern Nut	2
88-080-09	5/16 x3/4 NC Bolt	2
88-089-80	5/16 NC Nut	2
75-224-14	Diode, 1 AMP	4

CAUTION: Disconnect main battery leads. Place forward/reverse switch in neutral. Remove key from key lock before doing any electrical work on vehicle.

- 1) Locate and drill mounting holes and mount 62-025-00 panel assembly as shown (page 22 of section 14).
- 2) Install 78-001-00 fuse on the main negative at the battery with 62-025-05 strap, 88-080-09 5/16 x 3/4 nC bolt, 88-089-80 5/16 NC nut, as shown (page 22 of section 14)
- 3) Remove lower strap between coils, neg on isolator and forward solenoid. Move diode jumper lead to forward solenoid negative if required (lengthening lead may also required). Install diodes (75-224-14) in direction indicated (page 23 of section 14). Band on diode corresponds to band on diode symbol.
4. Install 75-170-00 wire harness per pages 23 and 24. Insert wires 7 and 62 into accelerator module plug in positions 7 and 6 respectively. Application of water or light oil to wire end may make insertion easier.
5. Install 72-560-51 cover as shown on page 22.

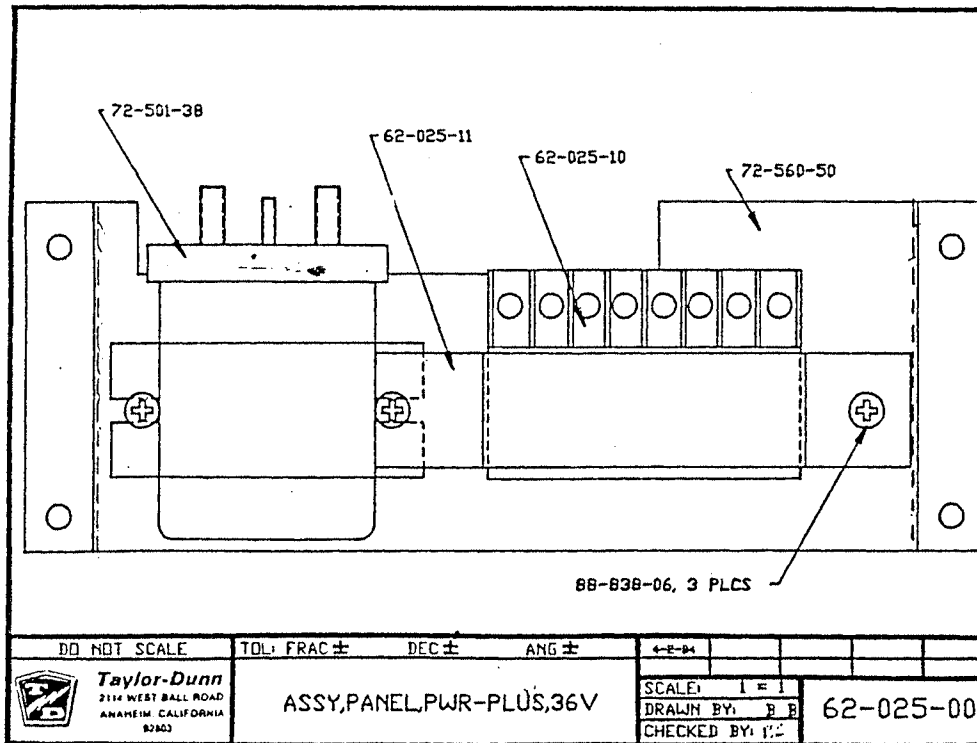
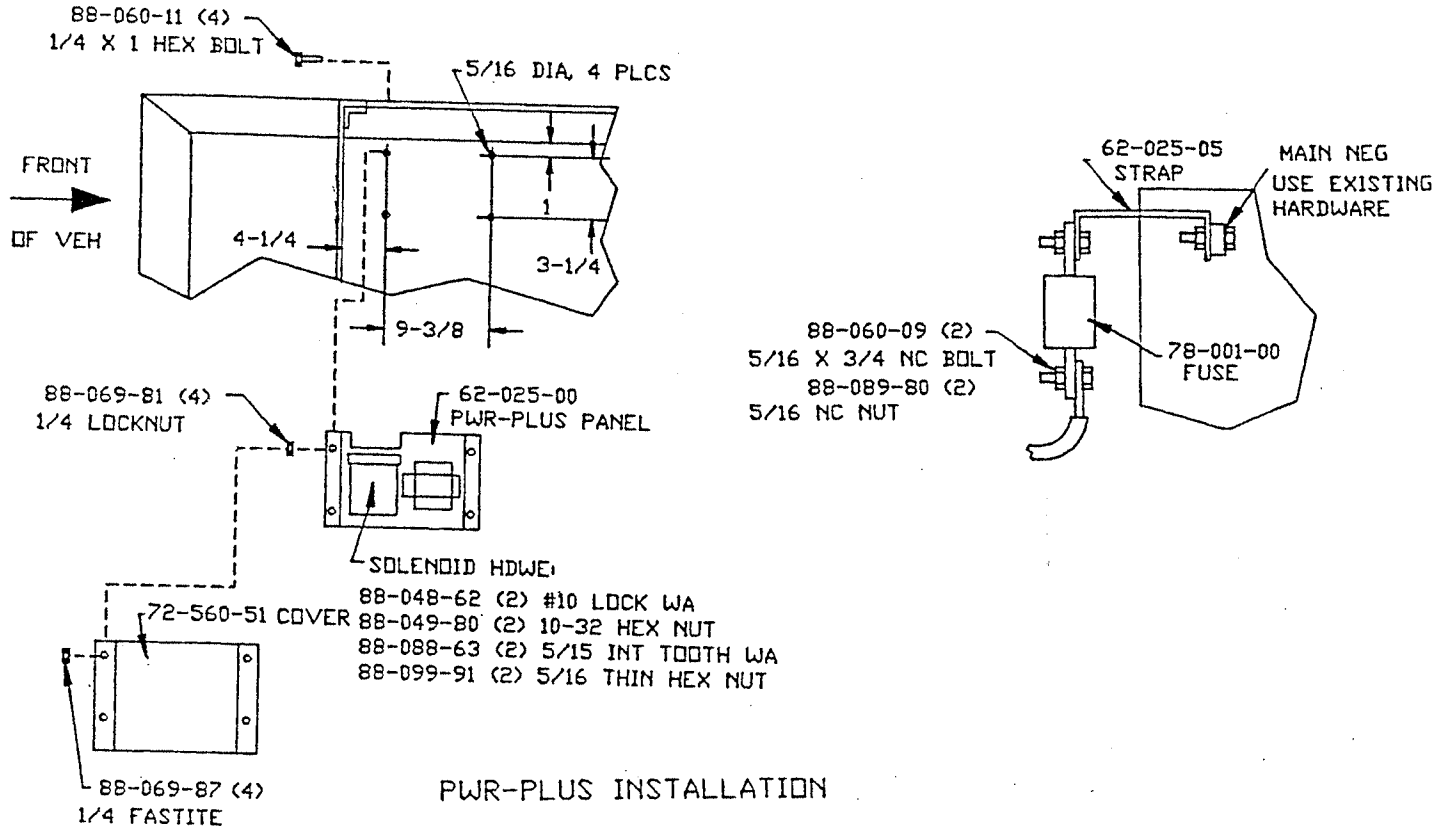

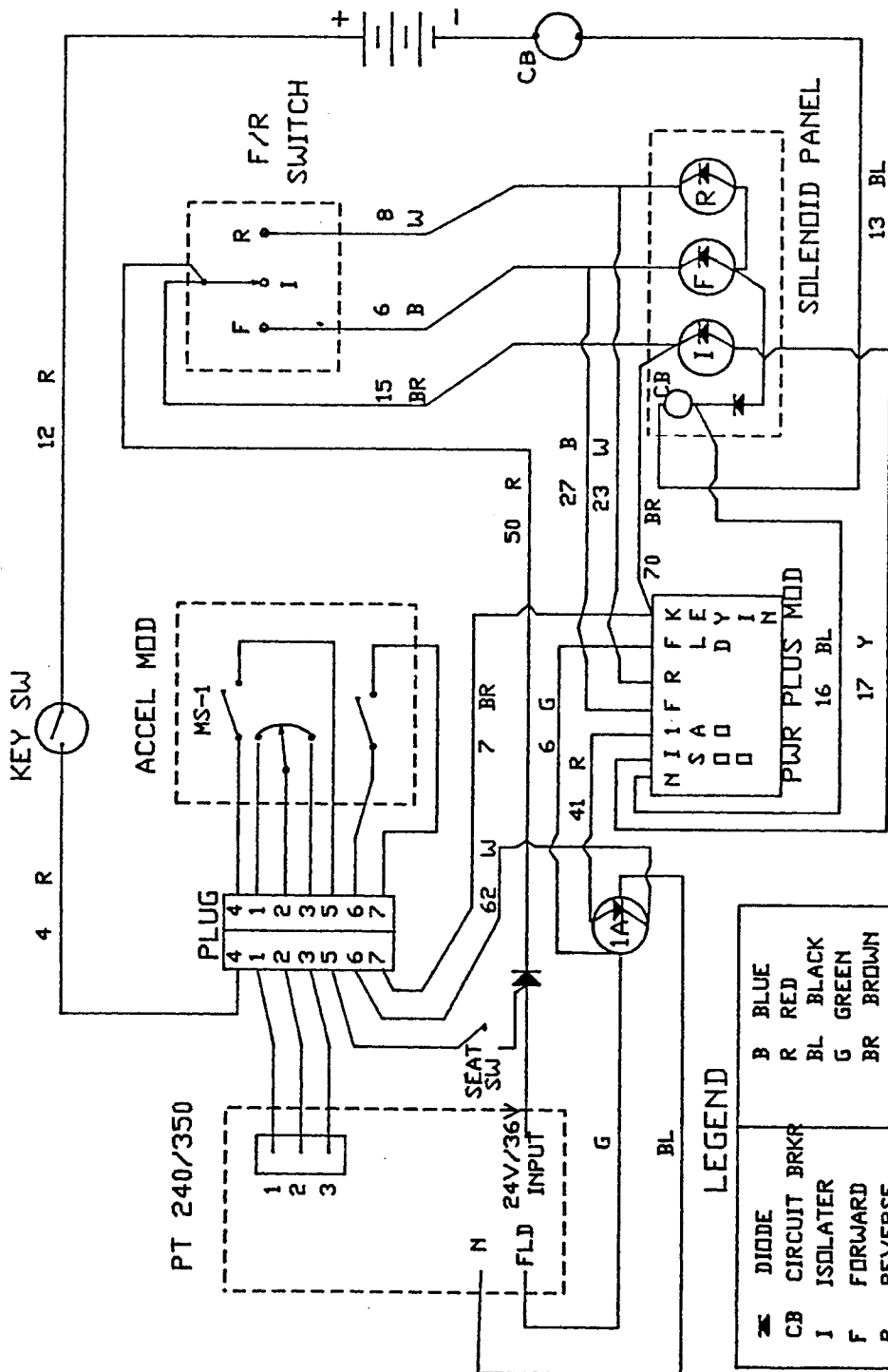

12-14-84

WIRE IDENT	COLOR	WIRE GAGE	CUT LENGTH	FROM		TO		TERMINATION SIZE		NOTES:
				UNIT	TERMINAL	UNIT	TERMINAL	FROM	TO	
7	BROWN	18	107	ACCEP. PLUG	PN SOCKET	ISO - MODUL. 15-421-01	3/16 SPLIT			REF T/D # 75-421-01
62	WHITE	18	108	ACCEP. PLUG	PN SOCKET	ISO - MODUL. 15-421-01	3/16 PIN			REF T/D # 75-421-01
41	RED	18	4	1A BYPASS	3/16 SPLIT	1A BYPASS FOR	3/16 SPLIT			FOR 3/16 SPLIT TERM
6	GREEN	18	5	FIELD	3/16 SPLIT	1A BYPASS FOR	3/16 RING			
27	BLUE	18	23	FORWARD SOL	3/16 SPLIT	FORWARD - MODULE	3/16 SPLIT			REF T/D # 75-440-51
23	WHITE	18	23	REVERSE SOL	3/16 SPLIT	REVERSE - MODULE	3/16 SPLIT			FOR PIN SOCKET
70	BROWN	18	24	ISO - MIDDLE	3/16 SPLIT	ISO - SOL. MODUL. 15-421-01	3/16 SPLIT			TERM
17	YELLOW	18	23	ISO - SOL. MODUL. 15-421-01	3/16 SPLIT	ISO - SOL. MODUL. 15-421-01	3/16 SPLIT			TERMINALS MUST BE INSULATED,
16	BLACK	18	16	NEUTRAL - MODULE	3/16 SPLIT	FORWARD - SOL.	3/16 SPLIT			HEAT SHRINK
-	GREEN	4	24	PT. CONTROL - N	1/4 RING	1A BYPASS FOR	5/16 RING			ACCEPTABLE
-	BLACK	4	25	PT. CONTROL - FLD	1/4 RING	1A BYPASS FOR	5/16 RING			

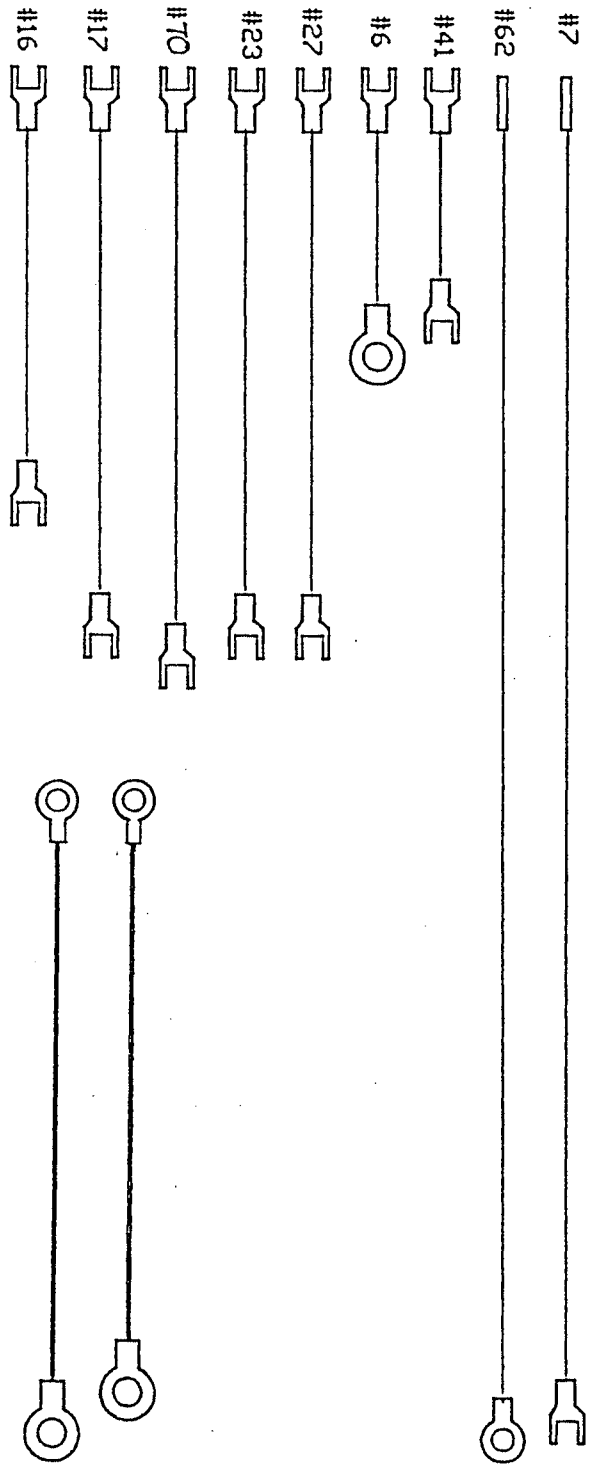

B 2-10 PWR-PLUS WIRE LIST

SERVICING

WARNING: BEFORE WORKING ON THE PWR-TRON UNITS OR ANY PART OF THE VEHICLE ELECTRICAL SYSTEM, DISCONNECT BOTH THE MAIN POSITIVE AND NEGATIVE BATTERY LEADS. PLACE THE FORWARD/REVERSE LEVER IN NEUTRAL, TURN OFF AND REMOVE. ALWAYS SET PARKING BRAKE (SEAT UP).

TROUBLESHOOTING:

Assuming function of PWR-TRON control; see step 1D for technique of disconnecting PWR-PLUS test functions.

1. Vehicle does not run.
 - A. Check with VOM for shorted solenoid (prevents operation logic function #3.
 - B. Check for shorted diodes across solenoids.
 - C. Remove green power (4 ga.) lead from by-pass solenoid. Install test light between S1 on motor and FLD post on controller. Connect battery and test. Test with accelerator. If light operates, either solenoid or motor shorted.
 - D. If test C shows failure, disconnect yellow wire #17 from PWR-PLUS logic and connect to negative and solenoid circuit breaker. Test with accelerator. If light works, replace PWR-PLUS logic. If light does not work, examine PWR-TRON circuitry for fault.

2. Vehicle runs but by-pass does not engage.
 - A. Check microswitch in accelerator with VOM to insure closing with pedal depressed. Connect meter between #7 (brown) at PWR-TRON logic and #62 (white) at by-pass solenoid.
 - B. Check for click of by-pass solenoid. If click but no engagement, replace solenoid.
 - C. Disconnect red wire (#41) at 1A0 on PWR-PLUS logic, with test light in place (see 1C), measure voltage at solenoid coil. Reading should be 36V with microswitch closed (no reading indicates fault in circuit). Reconnect red wire (#41) and test for voltage at logic module. If reading stays at 36V, replace logic module. If voltage stays at 0V, replace solenoid.

SERVICING continued

3. Vehicle By-pass Sporadic, Does Not Work on Steep Grades.

- A. Disconnect black power lead from by-pass solenoid. Apply brake to stall motor and depress accelerator. Measure voltage between green and black power lead. Reading should be 24 volts or less and solenoid should activate. If voltage is above 24 volts, replace motor. If voltage is less than 24 volts and solenoid does not engage, replace PWR-PLUS logic.

TROUBLE SHOOTING
(USE COMBINED CIRCUIT FOR CORRECTIVE ACTION)

<u>SYMPTOM</u>	<u>PROBABLE CAUSE</u>	<u>CORRECTIVE ACTION</u>
1. Vehicle goes forward does not move in reverse or vice versa	Motor to solenoid wired wrong or bad solenoid. Battery voltage too low, wire disconnected at solenoid, coil shorts on solenoid, causes circuit breaker to trip: Solenoid will not function	(See combined circuit) B neg from CB may be wired to field on PWR-TRON. Wire to B neg. if required, replace reverse solenoid.
2. Vehicle goes Rev/Fwd instead of Fwd/Rev Vehicle goes in one direction only also moves in neutral.	Wires reversed at Fwd/Rev switch. Solenoid welded shut in one position.	Route white wire from Fwd switch to motor. A1 and blue wire from reverse switch to motor, A2
3. Vehicle does not accelerate properly, full on, when checked with light	Solenoid GND connected to field input (green)	(see combined circuit) move to B neg. (same action as item no. 1
4. Catastrophic transistor failure during plugging	Motor/bat. lead to pos. (B+) on control omitted or mis-connected	(see combined circuit) * Replace transistor re-wire B+
5. Vehicle operates then stops. Motor whine present. <u>WARNING: Do not operate. Release accelerator immediately.</u> Continued operation could cause logic damage.	Plugging diode failure; 1. Yellow leads not properly connected. 2. Motor leads over 5' long 3. Incorrect diode	Route yellow leads to field terminal on PWR-TRON unit. Check plugging diode. Replace if necessary
6. Vehicle does not give smooth acceleration when viewed with test light.	Check accelerator module Potentiometer wired incorrectly. (yellow, black green)	Reroute yellow, black, and green wires per combined circuit diagram.
7. Test light indicates acceleration but turns off at full speed.	Cam reversed on accelerator module	Remove accelerator module. Remove accelerator arm/shaft, re-install cam. correctly
8. No output from control	Batteries <u>not</u> connected or improperly connected Key switch input not connected/key-off micro switch not connected (no solenoids on)	First, check key is on. Make certain trim-pot has not been turned too far. (into "overtravel" area)

TRUBLE SHOOTING (CONTINUED)
(USE COMBINED CIRCUIT FOR CORRECTIVE ACTION)

<u>SYMPTOM</u>	<u>PROBABLE CAUSE</u>	<u>CORRECTIVE ACTION</u>
9. No apparent output motor whines.	Grade or load is too great. Motor armature or field short.	See item 1. One direction missing, same action as item no. 1.
10. Vehicles "growls" during acceleration	PWR-TRON B+ to reverse solenoid (red lead) wired wrong.	(See combined circuit) Red lead from B+ tied to outside post. Re-wire red lead to reverse terminal post as on reverse solenoid.
11. Vehicle shudders and shakes	Battery voltage too low	Check batteries re-charge as necessary
12. Vehicle stalls, sits and whines	Bad accelerator pot or due to pulley turning free on pot shaft.	Apply "Super Glue" to pulley. If pot is O.K. and pulley is not loose on shaft, then adjust plugging pot 1/4 turn.

* Transistors must be replaced as matched sets: See respective page for speed controller.

SUGGESTED SPARE PARTS LIST
PWR-TRON SPEED CONTROLLER SYSTEM

T-D PART NO.	DESCRIPTION	QTY. NO. OF CARTS		
		REQ. 1-20	21-50	50-UP
62-024-00	PT-240 Speed Controller	1	1	2
62-024-20	Flywheel Diode	0	2	4
62-024-30	Plugging Diode	0	2	4
62-024-60	Drive Transistor	0	2	4
62-024-65	Power Transistor	0(set)	2	4
62-024-40	Capacitor	0	1	2
62-024-75	Thermal Switch	0	1	2
62-024-76	Resistor	0	1	2
62-024-77	Resistor	0	1	2
62-024-10	Cover PT-240	1	2	4
72-501-36	Solenoid SPST 36V	1	1	2
72-501-37	Solenoid SPDT 36V	2	2	4
79-840-00	Circuit Breaker	1	1	2
61-838-20	Buss, Curved	1	1	2
72-235-20	Jumper, 4-1/4 In X 4 Ga. Red	2	2	4
75-224-10	Jumper, 18 Ga w/diode	1	2	4
75-560-51	Cover, Solenoid Panel	1	2	4
62-030-13	Accel Module (B 2-10)	1	1	2
62-030-33	Rotor, Accel Module (B 2-10)	0	1	2
62-030-58	Cover, Accel Module	1	2	4
78-350-61	Potentiometer Kit	0	1	2
71-127-00	Micro-Switches	0	2	4
62-035-00	PT350 Speed Controller	1	1	2
62-035-21	Diode, Flywheel	0	2	4
62-035-21	Diode, Plugging	0	2	4
62-035-22	Capacitor	0	2	4
62-035-25	Logic Unit	0	1	2
62-035-28	Block, Transistor	0	1	2
62-035-33	Base Plate	0	1	2
62-035-32	Transistors, Power (set)	0	1	2
62-035-31	Transistors, Driver (set)	0	1	2
62-035-38	Trans. Assy, Driver, Driver	0	1	2
62-048-23	Block Terminal	0	1	2
62-024-29	Key Switch	0	1	2
62-024-36	Resistor, 10 W 70 OHM	0	1	2
62-035-36	Resistor, 50 W 5 OHM	0	1	2
62-035-37	Resistor, 10 W 18 OHM	0	1	2
62-035-10	Cover, PT 350	1	2	4
62-025-00	Assy, Panel, PWR-PLUS 36V	1	1	2
78-001-00	Fuse, 300 Amp	1	2	4
75-224-14	Diode, 1 Amp	4	6	8
72-560-51	Cover, Solenoid Panel	1	2	4

SUGGESTED SPARE PARTS LIST

T-D PART NO.	DESCRIPTION	QUANTITY OF 1 - 20 UNITS
11-040-00	Tube, 500 x 8	1
11-041-00	Tube, 950 x 8 or 850 x 8 (optional)	1
13-742-00	Tire, and Demountable Wheel, 500 x 8, 4 Ply, Super Rib Tire with 5-1/2" Holes on 4-1/2" bolt circle	1
13-746-00	Tire , and Demountable Wheel, 800 x 8, 4 Ply, Terra Tire Power Rib, 5-1/2" Holes on 4-1/2" bolt circle	1
13-742-11	Tire and Demountable Wheel 4.80 x 8 Split Rim, 5 Holes, on 4-1/2 Bolt Circle	1
13-742-12	Tire and Demountable Wheel, 5.70 x 8, 6 Ply	1
13-745-00	Tire, Tube and Demountable Split Wheel Rim with With 500 x 8, 8 Ply Steelguard Tire, 5-1/2: Holes On 4-1/2" Bolt Circle	1
45-506-00	Oil Seal for G.E. Motor	1
-----	DC Electric Motor. See Section 13 for Part No. I.D. of Motor Supplied with Vehicle.	1
-----	Motor Brushes. See Section 13 for Part No. I.D. of Brushes Supplied with Vehicle	4
71-039-00	Switch, Light (Double Pole, Double Throw)	1
71-501-00	Horn Button	1
72-072-00	Headlight, sealed beam bulb 4" (12 volt)	1
77-200-00	Hydrometer	2
77-201-00	Battery Filler	1
85-233-00	Spring Extension, 11/16" OD x 6-1/4", Accelerator Return	2
85-123-00	Spring, Deadman Seat	1
85-250-00	Spring Extension 1-1/16" OD x 3-5/8", Brake Pedal Return	1
71-120-00	Key switch	1

NOTE: FOR SPEED CONTROLLER SPARE PARTS SEE SECTION 14

PARTS ORDERING PROCEDURE

Parts may be purchased from your local authorized Taylor-Dunn Dealer. When ordering parts, be sure to specify the complete model number and serial number of this unit. Also specify the full Taylor-Dunn part number, description of part and quantity of parts required. You will find a complete listing of part numbers and descriptions in the following pages of this manual. When ordering parts for the drive motor, also include the specifications found on the motor name plate. Be sure to give complete shipping and billing address on all orders. Example:

- 1 - Part number - 86-501-98 - Ball Joint (Left Hand Thread)
- 1 - Set of 2 - Part Number - 70-005-00 - Brush Assembly
G.E. Motor, 36 Volt

Above parts for model 1210B Truck, beginning with Serial Number 79010

Parts ordered under warranty must be placed with your authorized Taylor-Dunn Dealer. Be sure to include original invoice number, date of shipment of vehicle, and vehicle serial number.

NOTE: On contracts with National Federal Government Agencies, Defense General Supply Agency, and United States Post Office Department, orders for all warranty parts must be placed directly with the Taylor-Dunn Factory in Anaheim, California.

TAYLOR-DUNN MANUFACTURING COMPANY
2114 West Ball Road
Anaheim, California 92804

Phone: 714-956-4040
Telex: 65-5393

MAINTENANCE PROCEDURES
BODY AND TRIM

Your vehicle has been finished with several coats of durable baked on enamel.

It will require the same care as you would give your automobile. The chrome trim is also resistant to corrosion and will require an occasional cleaning.

It is recommended that your vehicle be washed with a mild soap and warm water. For long life a good automotive type of wax will extend the life of the finish and maintain lasting beauty.

BODY AND TRIM

PART NO.	DESCRIPTION	QTY.
50-243-00	1/4" Battery, Hold Down Rod 11-3/4 In.	2
90-172-00	Cushion Back, Black	1
50-250-00	Clamp, Battery, BAT-LOK	2
90-175-00	Seat Cushion, 2nd & 3rd Seat, Solid Black, Model B	2
90-173-00	Cushion, Deadman Seat, Black (18 x 18)	1
90-174-00	Seat Cushion, (18 x 19-1/2) Model B, Solid Black, Passenger	1
00-210-15	Deck Rails, Side	2
00-210-13	Deck Rails, Rear	1
90-444-00	Deck Board, 5/8" Plywood, Black, Hi-density Cover 41 x 75-1/4	1
90-540-00	Stake Side, Side Gate Hook	2
90-545-01	Gate, End W/Hooks	1
90-545-02	Gate, Side W/Hooks	2
90-852-20	Windshield, Safety Glass (23 x 41)	1
91-010-36	Cab Door, Assembly, Left Side	1
91-010-37	Cab Door, Assembly, Right Side	1
91-010-62	Cab, Assembly (no doors) W/Windshield	1
91-151-00	Fiberglass Top, Cover (White)	1
91-028-20	Tubular Top Frame, Model B	1
91-028-24	Post, Support for Top Frame	4
91-101-00	Surrey Top Cover With Fringe	1
92-000-00	Chrome Wheel Cover 8" for 400 x 8 and 500 x 8 Wheel	2 or 4
92-001-00	Chrome Wheel Cover 6"	2 or 4
92-002-00	Chrome Wheel Cover 8" for Split Rim Wheel	1
92-201-00	Mirror, 4 x 8	1
92-202-00	Mirror Bracket	1
94-201-10	Taylor-Dunn Nameplate 4 x 5	1
94-050-00	Lens, Light Front	2
72-072-00	Headlight, 4 In., 12 Volt	2
95-952-00	Paint - 1 Qt. Can (Specify Color)	1
98-311-10	Window Channel for Windshield	1
98-313-00	Window Channel for Rear Cab Window	1
98-316-11	Channel, Window Dbl. x 30" Inside	2
98-317-10	Channel, Window Edge x 17" Outside	2
98-451-11	Tape Seal 1"x 3/8" (By The Foot)	1
98-454-00	Weatherseal, Door (By The Foot)	1
74-017-00	Discharge Indicators	1
74-000-00	Hourmeter, 12V to 48V	1
71-039-00	Accessory Switch (Rocker)/Lights	2
74-050-62	Windshield Wiper, Kit	1
02-210-25	Wire Cover, Angle	1
00-210-22	Guard/Light	1
72-025-00	Tail Lights	2
74-304-10	Panel, Instrument	1
98-757-00	Rubber Bumpers	2

BODY AND TRIM
(OPTIONAL) FIELD KITS

The following field kits are supplied as an additional option for customizing your B 2-10. Each kit comes complete with hardware and a set of instructions. See 5 for * illustrations of major kit packages. All metal parts are orange. All other colors are special.

KIT NO.	DESCRIPTION
90-010-61	Second Seat
90-010-62	Second and Third Seat
90-440-45	Diamond Cover Standard Bed B 2-10
90-440-55	Diamond Deck Cover 3 Piece
97-804-61	Pintle Hitch
97-808-61	Automatic Coupling Hitch
91-101-61	Surrey Top
91-151-61	Fibreglass Top
*91-340-62	Tool Box Double Side Doors
*91-542-61	Stake Sides 2 Passenger
90-542-62	Stake Sides 4 Passenger
74-010-61	Windshield Wiper
*91-010-62	Cab (all metal) With Windshield and Rear Window, Less Doors
*91-010-68	Door (all metal) With Sliding Glass Window, Left Hand
91-010-69	Door (all metal) With Sliding Glass Window, Right Hand
74-141-61	Turn Signals, Front and Rear
41-350-63	Front Axle W/Hydraulic Disc Brakes
86-602-61	Shocks, Front
86-602-62	Shocks, Rear
90-160-61	Seat Belts
73-005-60	Reverse Warning Beeper
73-005-61	Motion Beeper
72-023-61	Rotating Amber Light, Pole
72-023-62	Rotating Amber Light, Cab
92-202-60	Mirror
62-025-60	PWR-PLUS 36V

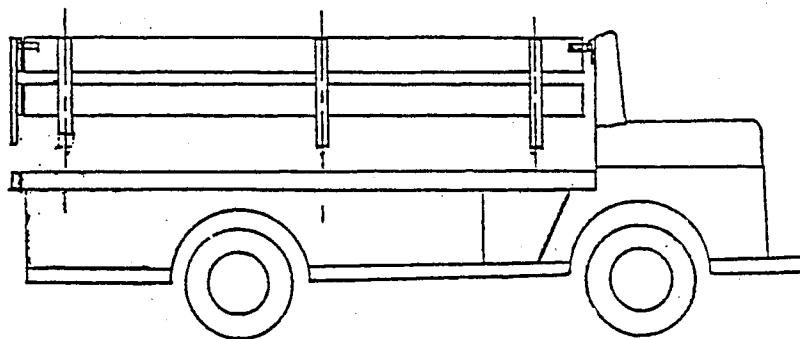
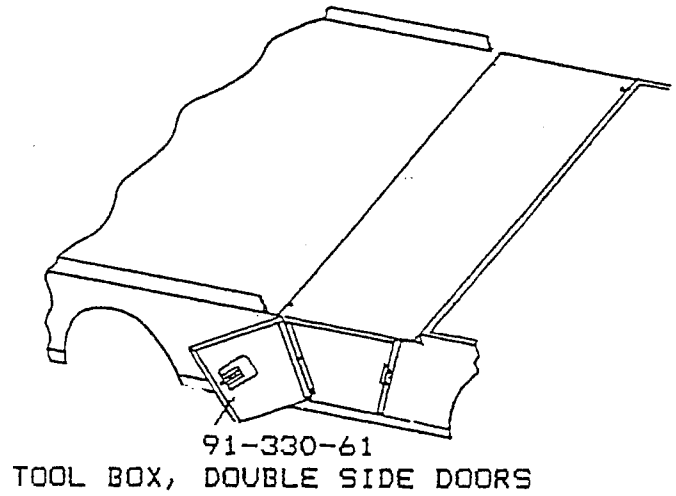
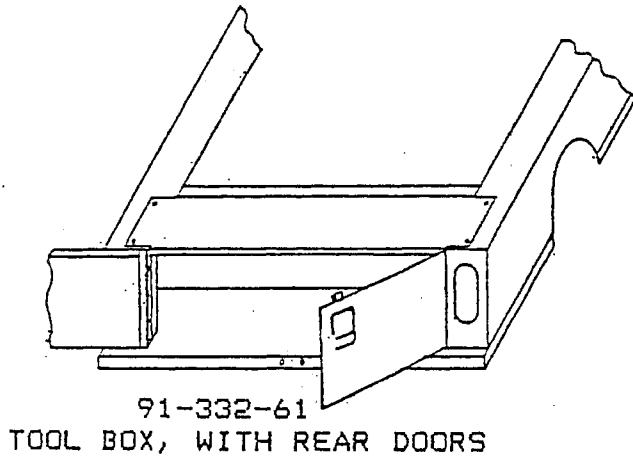
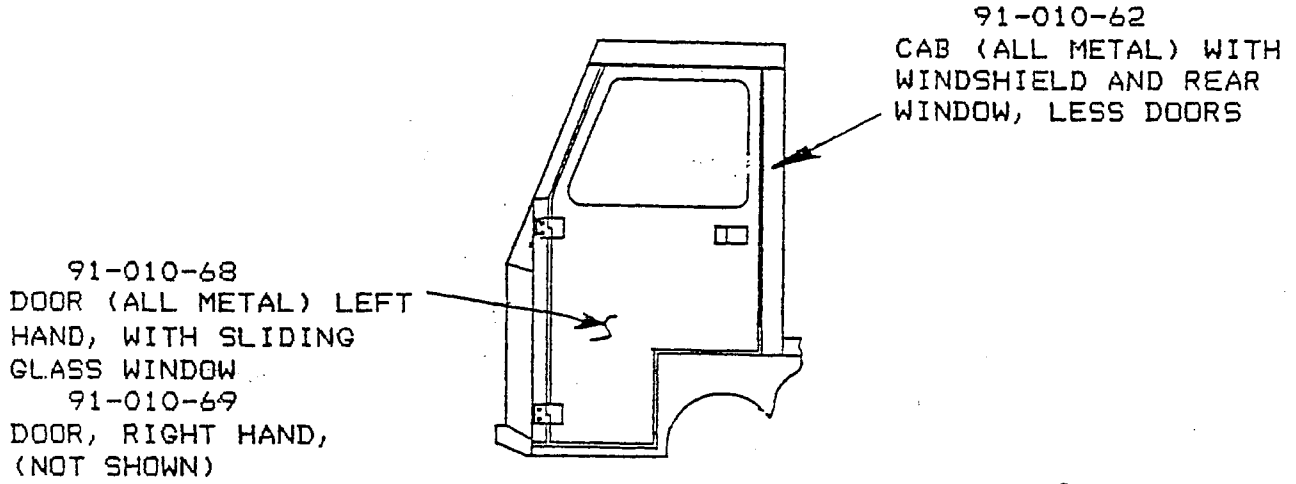

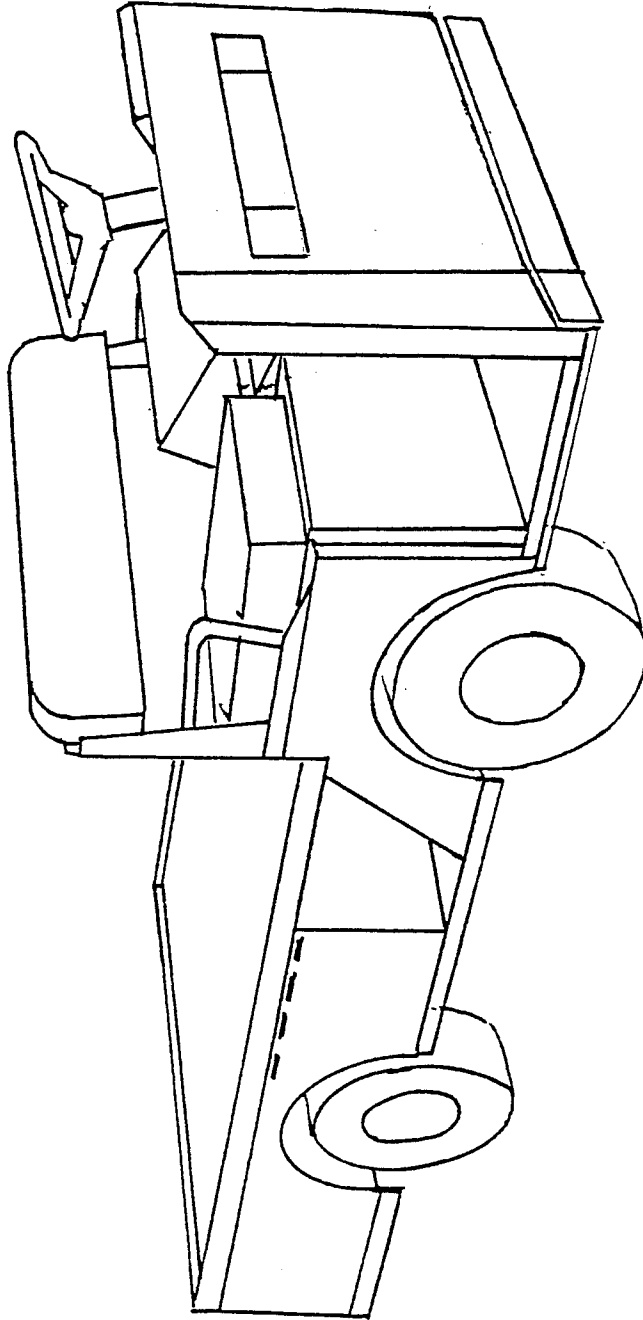

MODEL B 2-10

FRONT PIECE

N O T I C E O F C H A N G E

WE WANT OUR MANUALS TO BE USEFUL AND CORRECT. IF YOU DISCOVER AN ERROR OR WISH TO SUGGEST CHANGES, PLEASE FILL OUT THIS SHEET AND MAIL IT TO TAYLOR-DUNN.

MANUAL NO. _____ SERIAL NO. _____ DATE: _____

* AN ERROR(S) EXISTS ON THE FOLLOWING SECTION(S) AND PAGE(S) NO.

SECTION _____	PAGE NO. _____	LINE OR ITEM _____

* **EXAMPLE:** Section 13, Page 5, Item 5.
PART NO. 41-350-55 KIT, CYLINDER REPAIR SHOULD BE PART NO. 41-350-66.

MAIL TO: TAYLOR-DUNN
ATTN: ENGINEERING
2114 W. BALL ROAD
ANAHEIM, CA 92804

=====

N O T I C E O F C H A N G E

WE WANT OUR MANUALS TO BE USEFUL AND CORRECT. IF YOU DISCOVER AN ERROR OR WISH TO SUGGEST CHANGES, PLEASE FILL OUT THIS SHEET AND MAIL IT TO TAYLOR-DUNN.

MANUAL NO. _____ SERIAL NO. _____ DATE: _____

* AN ERROR(S) EXISTS ON THE FOLLOWING SECTION(S) AND PAGE(S) NO.

SECTION _____	PAGE NO. _____	LINE OR ITEM _____

* **EXAMPLE:** Section 13, Page 5, Item 5.
PART NO. 41-350-55 KIT, CYLINDER REPAIR SHOULD BE PART NO. 41-350-66.

MAIL TO: TAYLOR-DUNN
ATTN: ENGINEERING
2114 W. BALL ROAD
ANAHEIM, CA 92804