

The Best Way
To Go
About Your
Business

TAYLOR-DUNN[®]

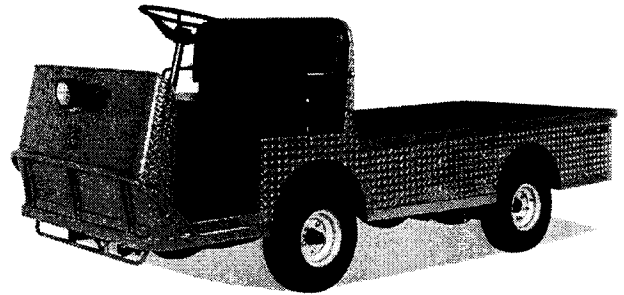

Models Included:

B2-38

B2-48

B2-54

Equipped with Ford drive system

MANUAL MB-248-09

Operation, Troubleshooting and
Replacement Parts Manual

Revision: A

Serial number starting: 151285

Operator and Maintenance Manual

*A guide to the operation and maintenance of Taylor-Dunn®
Vehicles*

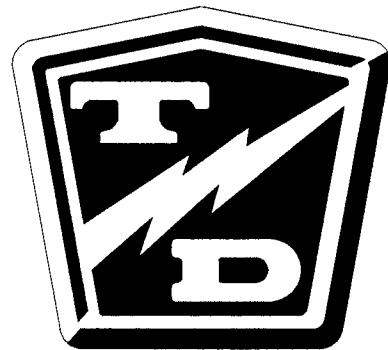

COPYRIGHT NOTICE

Copyright © 2001 by Taylor-Dunn® Mfg. All rights reserved.

No part of this work may be reproduced or transmitted in any form or by any means, electronic or mechanical, including photocopying and recording, or any information storage or retrieval system without prior written permission of Taylor-Dunn® Mfg. unless such copying is expressly permitted by federal copyright law. Address inquiries to Reference Permissions, Taylor-Dunn® Mfg., 2114 W. Ball Road, Anaheim, CA 92804

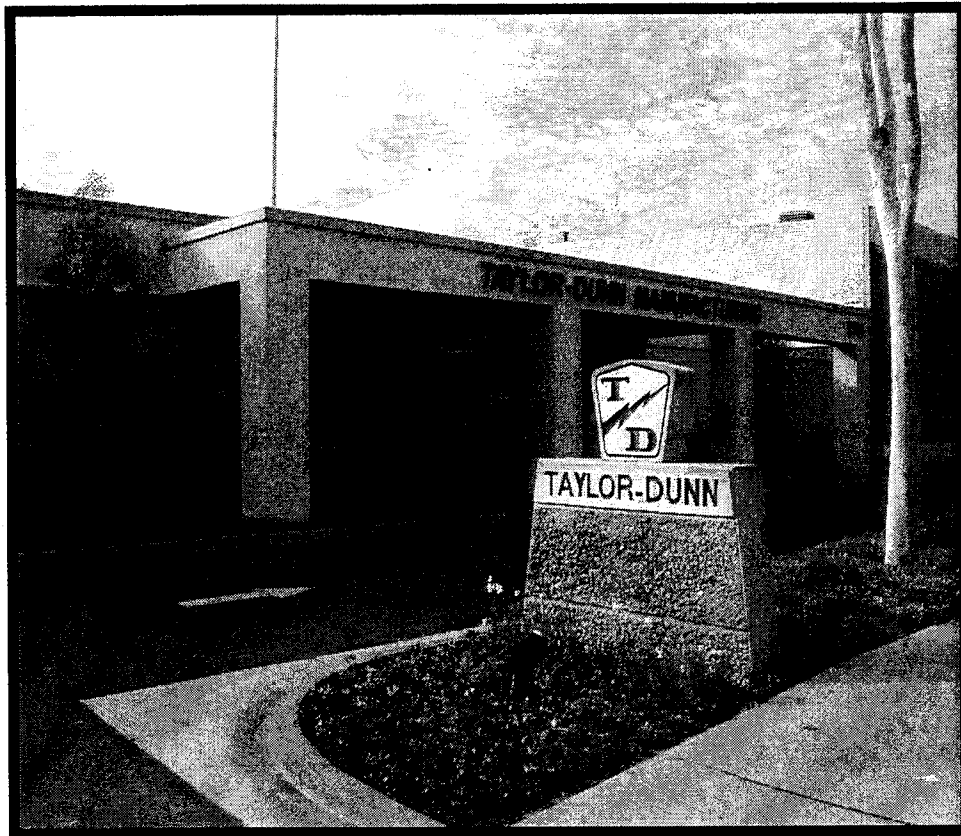

TAYLOR-DUNN SERVICE CENTER

For more information about this and other Taylor-Dunn® manuals, please write Taylor-Dunn®:

**Taylor-Dunn® Mfg.
2114 W. Ball Road
Anaheim, CA 92804
(Attn: Technical Writer)**

Table of Contents

Introduction

ABOUT THIS MANUAL	1-2
NOTATIONAL CONVENTIONS	1-2
Vehicle Description.....	1-3
STANDARD SPECIFICATIONS B 2-48/54	1-4
TAKING DELIVERY OF YOUR VEHICLE	1-5
Inspecting the Vehicle	1-5
What To Do If You Find A Problem	1-5

Safety Rules and Operational Information

Safety Rules and Guidelines	2-2
DRIVER TRAINING PROGRAM	2-3
Driver Qualifications.	2-3
VEHICLE CONTROLS	2-4
Key-Switch /Starter	2-4
Seat Interlock Switch (optional)	2-4
Forward-Reverse Switch	2-4
Accelerator Pedal	2-4
Steering	2-5
Foot Brake Pedal.....	2-5
Park Brake Lever	2-5
Horn Button	2-5
Instrument Panel.....	2-5
Hour Meter (optional)	2-5
Battery Status Indicator	2-5
Vehicle Operational Guidelines	2-6
Driving	2-6
Loading and Unloading	2-6
Parking	2-6
Towing	2-6
Storing and Returning to Service	2-7
Returning To Service	2-7

Maintenance and Service Procedures

Maintenance Guidelines	3-2
B2-48 and B2-54 LUBRICATION CHART	3-4
TROUBLESHOOTING GUIDE	3-5
Brakes	3-7
Disc Brakes	3-8

Brake Pads	3 - 8
Brake Figure 1: Exploded View of Disc Brake Assembly ..	3 - 8
Repairing the Brake Body	3 - 9
Bleeding the Brakes	3-10
Replacing the Master Cylinder	3-12
Brake Figure 3a: B 2-48/B2-38 Master Cylinder	3-13
Brake Figure 3b: B 2-54 Master Cylinder	3-13
Filling and Checking the Fluid Level	3-14
Brake Figure 4a: B2-38/B2-48 Master Cylinder	3-14
Brake Figure 4b: B2-54 Master Cylinder	3-14
Parking Brake	3-15
Park Brake Figure 1: Park Brake Assembly	3-15
Primary Adjustment	3-15
Secondary Adjustment	3-16
Park Brake Figure2: Exploded View of Parking Brake	3-16
Front Axle and Steering	3-17
Axle Removal B2-48	3-17
Axle Installation B2-48	3-18
Axle Removal B 2-54	3-18
Aligning the Front End B2-48/B2-54	3-19
Centering the Steering B2-48/B2-54	3-20
Repairing the Front Axle B2-48/B2-54	3-20
.....	3-21
Wheel Bearings B2-48/B2-54	3-22
Ball Joints B2-48/B2-54	3-23
Steering Gear Adjustment B2-48/B2-54	3-24
Endplay	3-24
Gear Lash	3-24
Steering Figure 2: Steering Gear	3-24
Drive Axle	3-25
Drive Chain Adjustments	3-25
Drive Figure1: Exploded View of Chain Case	3-25
Motor Removal	3-26
Motor Installation	3-26
Power Traction	3-28
Removing the Power Traction Assembly	3-28
Differential Service and Repair	3-29
Drive Figure 2: Exploded View of 3rd Member	3-29
Adjust the Backlash	3-30
Re-Shimming the Pinion Bearings	3-30
Selecting Pinion Housing Shims	3-31
Changing the Differential Oil	3-32
Rear Axle and Bearing Replacement	3-33

Drive Motor	3-34
Motor Disassembly	3-34
Replacing the Brushes	3-34
Inspecting the Armature	3-35
Battery	3-36
Cleaning	3-36
Battery Figure 1: Electrolyte Level	3-36
Servicing	3-37
Charging	3-37
Battery Storage	3-38
Tires	3-39
Servicing the Tires	3-39
Lubrication	3-40
Frequency of Lubrication	3-40
Lubricate all Zerk Fittings	3-41
Rear Axle Oil	3-41
Clean and Repack B2-48 and B2-54	
Front Wheel Bearings	3-41
B2-38 Front Wheel and Fork Bearings	3-41
Lubrication diagram for B2-38	3-42
Electrical Troubleshooting	3-43
Wire Diagram B2-38 / B2-48 / B2-54	3-49
LESTER CHARGER TROUBLESHOOTING	3-50
Testing the Interlock Relay	3-52
Operation	3-52
Testing	3-52
B2-38 Three Wheel Front Axle/Steering Supplement	3A-1
Removal	3A-2
Installation	3A-2
Centering the Steering	3A-2

Illustrated Parts

Front Axle B2-48	4-2
Front Axle B2-54	4-4
Front Suspension for B 2-48/B2-54	4-6
Steering Gear	4-8
Steering Column Assembly	4-10
Drag Link	4-10
Park Brake Linkage	4-12
Parking Brake	4-14
Foot Brake Linkage B2-48/B2-38	4-16
Foot Brake Linkage B2-54	4-18
Rear Brakes	4-20
Front Brakes	4-22
Accelerator/Brake Pedal	4-24
B2-48 Brake Lines and Hoses	4-26
B 2-54 Brake Lines and hoses	4-28
B 2-48 Rear Suspension.....	4-30
B2-54 Rear Suspension.....	4-32
Instrument Panel.....	4-34
Frame	4-36
Motors.....	4-38
B2-48 and B2-38 Standard Motor	4-40
Rear Axle B2-48	4-42
Rear Axle B2-54	4-44
3rd Member and Axle Assembly	4-46
Power Traction Assembly	4-48
Control Panel B2-38 and B2-48	4-50
Control Panel B2-54	4-52
Charger	4-54
Miscellaneous Electrical System Parts	4-56
Decals	4-58

APPENDIX A-Special Tools

APPENDIX B-Torque Values

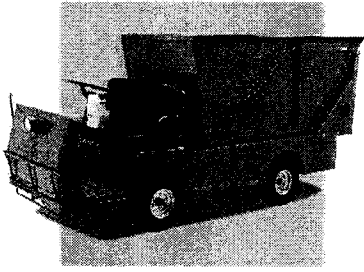

B2-48 With Dump Bed Option

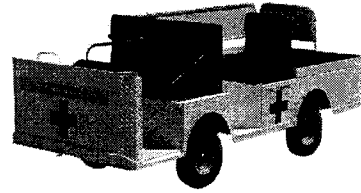

B2-10 Ambulance

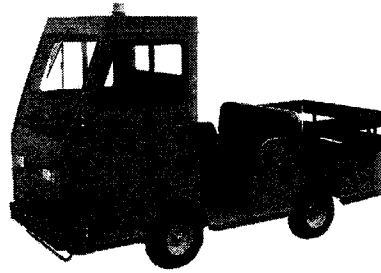

*B2-48 with Steel Cab, Foldaway
4-Passenger Seat and Stake Sides*

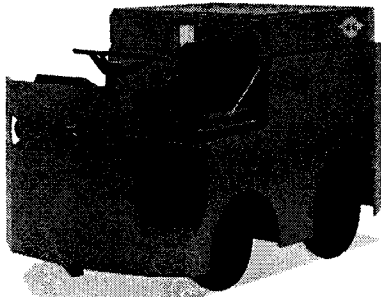

P2-50 30,000 Pound Tow Tractor

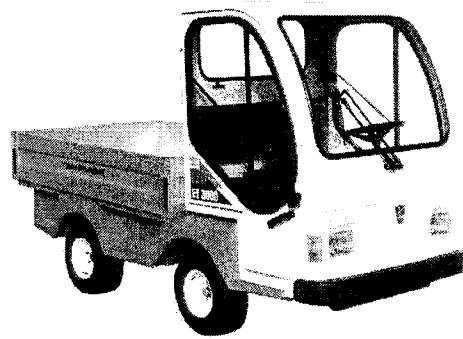

ET 3000

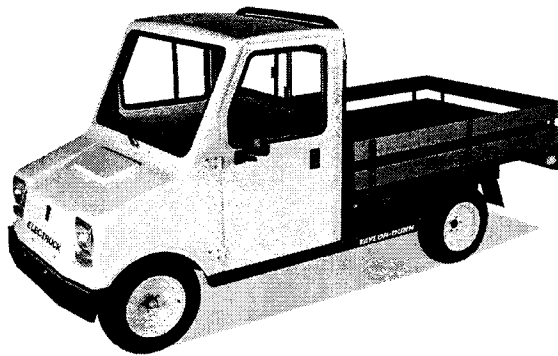

ET1-50 Full Size Truck

Introduction



Section 1***ABOUT THIS MANUAL***

This manual provides you with information you need to safely operate and maintain this vehicle.

We assume that those who will perform maintenance or repair operations are trained vehicle service technicians capable of performing minor and major repairs and qualified to use the tools required.

We also assume that they have or will attend a training program designed to familiarize them with the safe operation and use of this particular vehicle.

This manual contains the following major sections:

SECTION 1: INTRODUCTION

Contains information about how to use this manual, and a description of the B 2-48/38/54, how to do an incoming inspection and vehicle specifications.

SECTION 2: VEHICLE OPERATION

Provides safety rules and guidelines describes the driver training program and explains the operation of each control on the B 2-48/38/54.

SECTION 3: MAINTENANCE PROCEDURES

This section contains a scheduled maintenance checklist, lubrication diagram, troubleshooting guide, recommended spare parts list, and detailed maintenance procedures.

SECTION 4: SERVICE PROCEDURES

Contains service procedures in for each assembly found in the B 2-48/38/54. Each major heading contains procedures organized in logical order.

SECTION 5: ILLUSTRATED PARTS

Includes an illustration and parts list for each assembly that

NOTATIONAL CONVENTIONS

The following types of conventions are used throughout this manual:

 WARNING

A warning alerts you of something that may cause injury to yourself or others. Be sure you exercise special care and follow any instructions provided in a warning message.

 CAUTION

A caution informs you of something that may cause damage to the vehicle. Be sure you exercise special care and follow any instructions provided in a caution message.



A NOTE PROVIDES ADDITIONAL INFORMATION ABOUT A SUBJECT.

Vehicle Description

This manual applies to vehicles with serial numbers starting at 128029.

The B 2-48/38/54 is designed to be driven on smooth surfaces in and around industrial plants, nurseries, institutions, motels, mobile home parks, and resorts.

This vehicle is not designed to be driven on public highways. The B 2-48/38/54 is built to order. It is available in speeds ranging from 7 mph to 15 mph. The truck travels on a level surface with no load at this approximate speed. Do not exceed this speed. Exceeding this speed may result in steering difficulty, motor damage, and/or loss of control. It is not designed to be towed more than 5 mph.

The vehicle can handle a total payload (incl. cargo, optional equipment, passengers, and driver) of, up to 5000 pounds (depending on model and options), **see Standard Specifications Table on page 1-4**. The Vehicle Specification Tag will indicate model and capacity. Do not exceed this capacity. Various options are available to enable you to customize the vehicle to suit your particular needs (consult your Taylor-Dunn salesperson or representative for current options).

This vehicle conforms to requirements for Type E vehicles as described in O.S.H.A. Standard Section 1910.178 (Powered Industrial Trucks) and with all applicable portions of the American National Standard for Personnel and Burden Carriers (ANSI B56.8).

The model and serial number for this vehicle are imprinted on a decal located under the passenger seat, and stamped in a main frame rail directly below the front left (driver side) corner of the deck board.

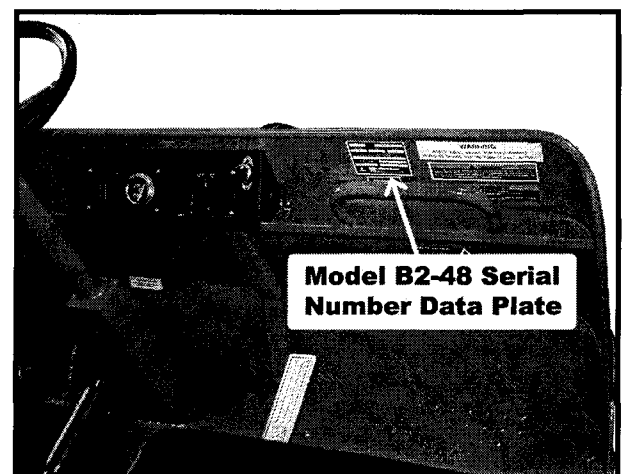
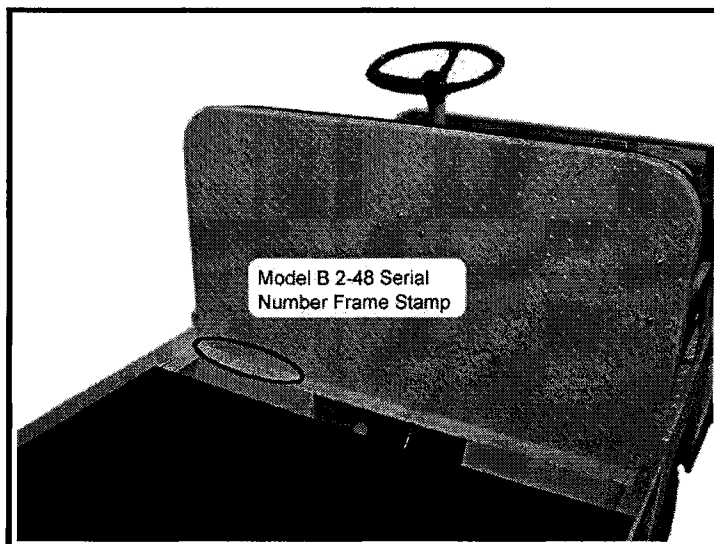

TAKING DELIVERY OF YOUR VEHICLE

THIS VEHICLE SHOULD BE INSPECTED IMMEDIATELY AFTER DELIVERY. Use the following guidelines to make sure there are no obvious problems.

Inspecting the Vehicle

Examine the contents of all packages and accessories that may have come in separate packages with this vehicle. Make sure everything listed on the packing slip is there. Nothing should look broken or damaged.

Examine any visible wiring for obvious signs of damage. Check that all connections are secure.

Check that battery connections are tight and all cells are filled.

Inspect the tires for obvious wear or damage. Check the tire pressure. Make sure that all wheel lugs are secure.

Check the body, seats, windshield (optional), trim and other external parts for obvious damage. Checking the Controls

Operate each of the following controls before turning on the key-switch:

- ◆ Accelerator pedal
- ◆ Brake pedal
- ◆ Forward - reverse selector lever
- ◆ Parking brake
- ◆ Steering wheel
- ◆ Horn
- ◆ Lights

Each control should operate smoothly and easily without sticking or requiring undue effort.

What To Do If You Find A Problem

If there is a problem or damage as a result of shipping, note the damage or problem on the bill of lading and file a claim with the freight carrier. The claim must be filed within 48 hours of receiving the vehicle and its accessories. Also, notify Taylor-Dunn® of the claim.

If there is a problem with the operation of the vehicle, **DO NOT OPERATE THE VEHICLE**. Immediately contact your local Taylor-Dunn® distributor and report the problem. The report must be made within 24 hours of receiving the vehicle and its accessories.

The only personnel authorized to repair, modify, or adjust any part of this or any Taylor-Dunn® vehicle is a factory authorized service technician.

WARNING

Do not repair modify or adjust any part of this vehicle unless you are authorized to do so. Incorrect repairs may result in injury to yourself and others and cause the invalidation of your warranty.

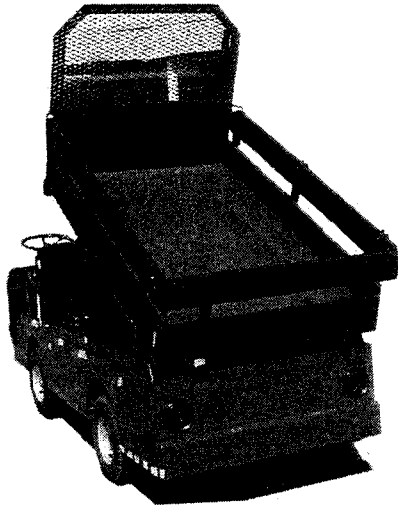

B2-48 With Stake Side Dump Bed Option

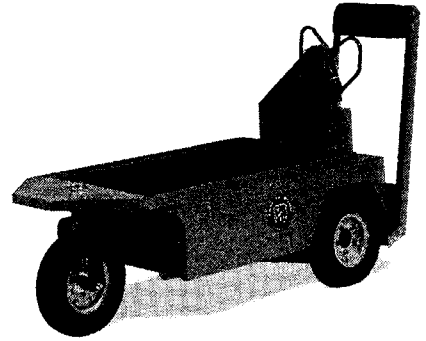

SC1-59 Stock Chaser

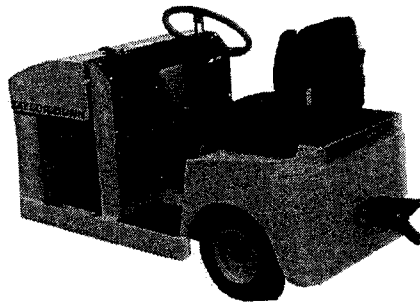

E4-55 Sit Down Tow Tractor

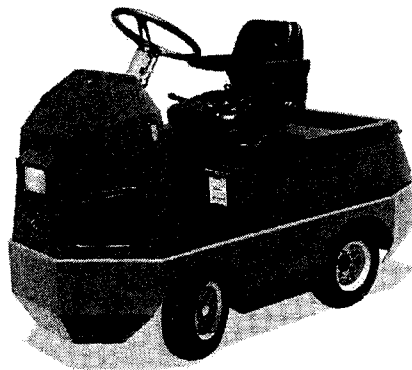

C4-25 Sit Down Tow Tractor

*Safety Rules and
Operational Information*



Section 2

Safety Rules and Guidelines

It is the responsibility of the owner of this vehicle to assure that the operator understands the various controls and operating characteristics of this vehicle. As well as, obeying the following safety rules and guidelines (extracted from the American National Standards Institute Personnel and Burden Carriers ANSI B56.8).

This vehicle is designed to be driven over smooth surfaces in and around places such as warehouses, nurseries, motels, parks, and resorts. Before you drive this vehicle, please observe the following safety rules and guidelines:

⚠ WARNING

This vehicle is not designed to be driven on public highways. The drive is built to order. It is available in speeds ranging from 7 mph to 15 mph. The truck travels on a level surface with no load at this speed. Do not exceed this speed. Exceeding this speed may result in steering difficulty, motor damage, and/or loss of control. It is not designed to be towed more than 5 mph.

- ◆ Do not drive this vehicle unless you are a qualified and trained operator.
- ◆ Keep all body parts (head, arms', legs') inside this vehicle while it is moving.
- ◆ Drive slowly when making a turn especially if the ground is wet slippery or when driving on an incline.
- ◆ This vehicle may overturn easily if turned sharply when driving at high speeds, especially when on an incline.
- ◆ Drive only on level surfaces or on surfaces having an incline of no more than 10% (5.6 degrees.).
- ◆ Do not drive over loose objects, holes, or bumps.
- ◆ Observe all traffic regulations and speed limits (15-mph max.).
- ◆ Keep to the right under normal conditions.
- ◆ Maintain a safe distance from all objects.
- ◆ Keep the vehicle under control at all times.
- ◆ Yield right of way to pedestrians, ambulances, fire trucks, or other vehicles in emergencies.
- ◆ Do not overtake another vehicle at intersections, blind spots, or other dangerous locations.
- ◆ Keep a clear view ahead at all times.

DRIVER TRAINING PROGRAM

The owner of this vehicle shall conduct an Operator Training program for all those who will be operating this vehicle. The training program shall not be condensed for those claiming to have previous vehicle operation experience. Successful completion of the Operator Training program shall be required for all personnel who operate this vehicle.

The Operator Training program shall include the following:

- ◆ Operation of this vehicle under circumstances normally associated with your particular environment.
- ◆ Emphasis on the safety of cargo and personnel.
- ◆ All safety rules contained within this manual.
- ◆ Proper operation of all vehicle controls.
- ◆ A vehicle operation and driving test.

DRIVER QUALIFICATIONS.

Only those who have successfully completed the Operator Training program are authorized to drive this vehicle. Operators must possess the visual, auditory, physical, and mental ability to safely operate this vehicle as specified in the American National Standards Institute Controlled Personnel and Burden Carriers ANSI B56.8.

The following are minimum requirements necessary to qualify as an operator of this vehicle:

- ◆ Demonstrate a working knowledge of each control.
- ◆ Understand all safety rules and guidelines as presented in this manual.
- ◆ Know how to properly load and unload cargo.
- ◆ Know how to properly park this vehicle.
- ◆ Recognize an improperly maintained vehicle.
- ◆ Demonstrate ability to handle this vehicle in all conditions.

Section 2
VEHICLE CONTROLS

The following describes the use of each control on this vehicle.

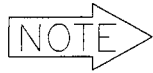

SOME CONTROLS ARE OPTIONAL EQUIPMENT AND MAY NOT BE INSTALLED ON THIS VEHICLE.

Key-Switch /Starter

A key-switch located on the right side of the instrument panel starts the vehicle. Rotate the key clockwise to turn the vehicle on counterclockwise to turn the vehicle off.

The key-switch should be in the off position whenever the operator leaves the driver's seat.

This switch is also designed to secure and disable the vehicle. You can remove the key ONLY when the key-switch is in the OFF position.

Seat Interlock Switch (optional)

A switch located under the driver's seat disables the vehicle when the driver leaves the seat. The driver must be seated for the vehicle to operate.



THIS IS AN ADDED SAFETY FEATURE AND SHOULD NEVER BE BYPASSED.

Forward-Reverse Switch

The forward-reverse rocker switch, located on the dash, determines the direction of travel (forward or reverse) of the vehicle. Push the top of the switch to make the vehicle go forward. Push the bottom of the switch to go in reverse.

DO NOT SHIFT from forward to reverse or vice-versa while the vehicle is in motion. Make sure the vehicle is completely stopped before shifting.

The Forward-Reverse switch has a neutral position. The Forward-Reverse switch should be in the neutral position with the park brake set whenever the operator leaves the driver's seat.

Accelerator Pedal

The accelerator pedal located to the right of the brake pedal. It controls the speed of the vehicle, is designed for right foot operation only, operates the same way as the accelerator pedal in an automobile, and controls the vehicle's speed.

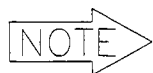

DEPRESS THE PEDAL TO SPEED THE VEHICLE UP. RELEASE THE PEDAL TO SLOWDOWN.

Steering

The steering wheel and steering system is an automotive type. To turn right, turn the steering wheel to the right (clockwise). To turn left, turn the steering wheel to the left (counter clockwise).

Foot Brake Pedal

The foot brake pedal located to the right of the steering column is for operation with the right foot only. It works the same as the brake in an automobile. Applying pressure to the brake pedal slows the vehicle according to the amount of pressure you apply. Removing your foot from the pedal releases the braking action.

Park Brake Lever

The park brake is actuated with a hand lever located on the floorboard to the right of the accelerator pedal. To set the park brake pull the lever back until it locks. To release the park push the lever all the way forward. The park brake can be adjusted using the adjusting knob on the end of the lever/handle. To learn more about this refer to the “Park Brake,” page 3-17

CAUTION

Do not operate the vehicle with the parking brake applied. Severe motor/control damage will result.

Horn Button

The horn button is located on the right side of the dash panel. Depress the button to sound the horn, release it to turn it off.

Instrument Panel

The headlight switch is located of the left side of the instrument panel. An accessory switch, if any, is adjacent and to the right of it.

Hour Meter (optional)

The hour meter is located to the right of the battery status indicator. This tracks the number of hours the vehicle has been in operation.

Battery Status Indicator

The battery status indicator is located to the right of the accessory switch.. The normal operating range is in the green zone. The vehicle needs charging if it is in the yellow zone to the left. If it is in the red zone to the left, the vehicle should be taken out of service immediately to be charged.

Section 2*Vehicle Operational Guidelines*

Driving

- ◆ Slow and sound the horn when approaching a corner or other blind intersection.
- ◆ No horseplay or dangerous driving.
- ◆ Do not drive this vehicle in hazardous areas unless this vehicle is approved and labeled for such operation.
- ◆ Immediately report any accident or vehicle problem to your supervisor.

Loading and Unloading

- ◆ Do not load cargo that can easily fall off this vehicle.
- ◆ Do not exceed the cargo load capacity of this vehicle.
- ◆ Do not carry more than the maximum number of passengers allowed for this vehicle.
- ◆ Be extra careful when handling cargo that is longer, wider or higher than this vehicle.

Parking

- ◆ Set the parking brake and place the forward and reverse switch in the OFF position before leaving the vehicle.
- ◆ If you will be away from this vehicle turn off the key-switch, remove the key and take the key with you.
- ◆ If you park this vehicle on an incline block the wheels.
- ◆ Do not block fire aisles, fire equipment, or stairways.

Towing

To tow these vehicles attach a tow strap to the front bumper tow-bar and place the forward and reverse switch in the OFF position. Use another driver to steer this vehicle while it is being towed. Be sure the driver uses the brakes when the towing vehicle slows or stops.

 WARNING *Do not exceed 5 MPH or carry any passengers while towing this vehicle.*

Storing and Returning to Service

- ◆ Do not store batteries in a discharged condition. Fill, charge, and clean batteries fully before putting in storage
- ◆ Lube all grease fittings. Spray all exposed metal surfaces with a light oil.
- ◆ Clean and dry all exposed electrical connections.
- ◆ Inflate tires to proper pressure and then block them off the ground.
- ◆ If stored for a prolonged period the batteries should be charged as follows;

Storage Temperature	Charge
Below 40° F	Every 6 months
40° - 60° F	Every 2 months
Above 60° F	Once a month

Returning To Service

Check state of charge of batteries and charge if necessary.

Perform **ALL** maintenance checks in the periodic checklist in section 3.

Test drive before putting into normal service.

TAYLOR - DUNN

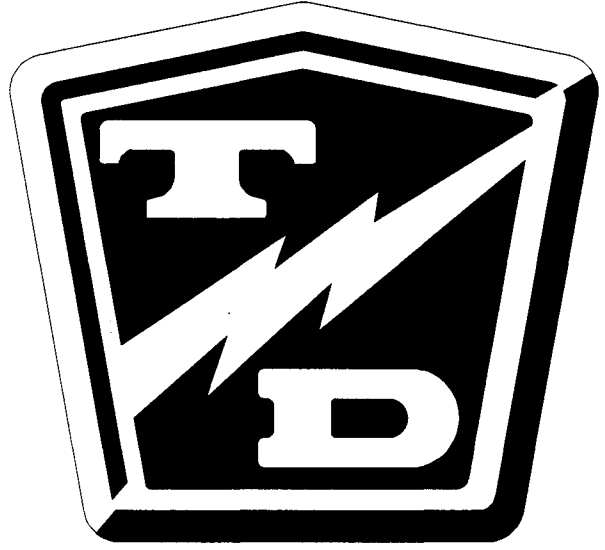

*Maintenance and Service
Procedures*



Section 3

This section explains how to perform the scheduled maintenance procedures. Use the Maintenance Checklist to determine how often you should perform each procedure. Vehicle maintenance or repairs should only be performed by a qualified mechanic.

This section contains the following:

- ◆ Maintenance guidelines.
- ◆ Maintenance checklist.
- ◆ Lubrication chart.
- ◆ Troubleshooting guide.
- ◆ Recommended spare parts list.
- ◆ Detailed maintenance procedures.

Maintenance Guidelines

- ◆ Regularly inspect and maintain in a safe working condition, brakes, steering mechanisms, speed and directional control mechanisms, warning devices, lights, governors, guards and safety devices.
 - ◆ Inspect and maintain battery limit switches, protective devices, electrical conductors and connections in conformance with Taylor-Dunn's recommended procedures.
 - ◆ Keep the vehicle in clean condition to minimize fire hazards and facilitate detection of loose or defective parts.
- ◆ Allow only qualified and authorized personnel to maintain repair adjust and inspect the vehicle.
 - ◆ Before starting any repairs or maintenance immobilize the vehicle by turning the key switch off, removing the key and setting the park brake.
 - ◆ Disconnect both of the main battery leads before working on or disconnecting any electrical component or wire.
 - ◆ Block the chassis with jack stands before working under a raised vehicle.
 - ◆ Conduct vehicle performance checks in an authorized area where safe clearance exists.
 - ◆ Before starting the vehicle, follow the recommended safety procedures in Section 2, "Vehicle Operation."
 - ◆ Avoid fire hazards and have fire protection equipment present in the work area. Do not use an open flame to check level or leakage of battery electrolyte. Do not use open pans of fuel or flammable fluids for cleaning parts.
 - ◆ Ventilate the work area properly.

Severe Duty Inspection: If these vehicles are operated in severe conditions all service procedures should be carried out twice as often as stated in the table on the next page. In addition the vehicle should be inspected monthly for signs of damage and repaired immediately.

SEVERE CONDITIONS refer to extremes in temperature and road conditions.

Periodic Maintenance Checklist					
Maintenace Item	Weekly (20hrs)	Monthly (80hrs)	Quarterly (250hrs)	Semi - Annual (500hrs)	Annualy (1000hrs)
Check Condition of Tires (pg 3-39)	X				
Check and Fill Batteries (pg 3-36 to 3-37)	X				
Check Brake System (pg 3-7 to 3-18)		X			
Check Steering System (pg 3-19 to 3-24)		X			
Lubricate Vehicle (pg 3-4, 3-40)			X		
Clean and Tighten All Wire Connections			X		
Wash and Service Batteries (pg 3-36 to 3-37)			X		
Check Park Brake (pg 3-17 to 3-18)				X	
Check Front Wheel Bearings (pg 3-22)				X	
Check Rear Axle Oil (pg 3-32)				X	
Change Rear Axle Oil (pg 3-32)					X
Check and Tighten all Nuts and Bolts					X
Clean and Repack Front Wheel Bearings (pg 3-22)					X

The page numbers listed in the table above are meant only as a guide to help you find the general infromation in this manual.

Section 3

B2-48 and B2-54 LUBRICATION CHART

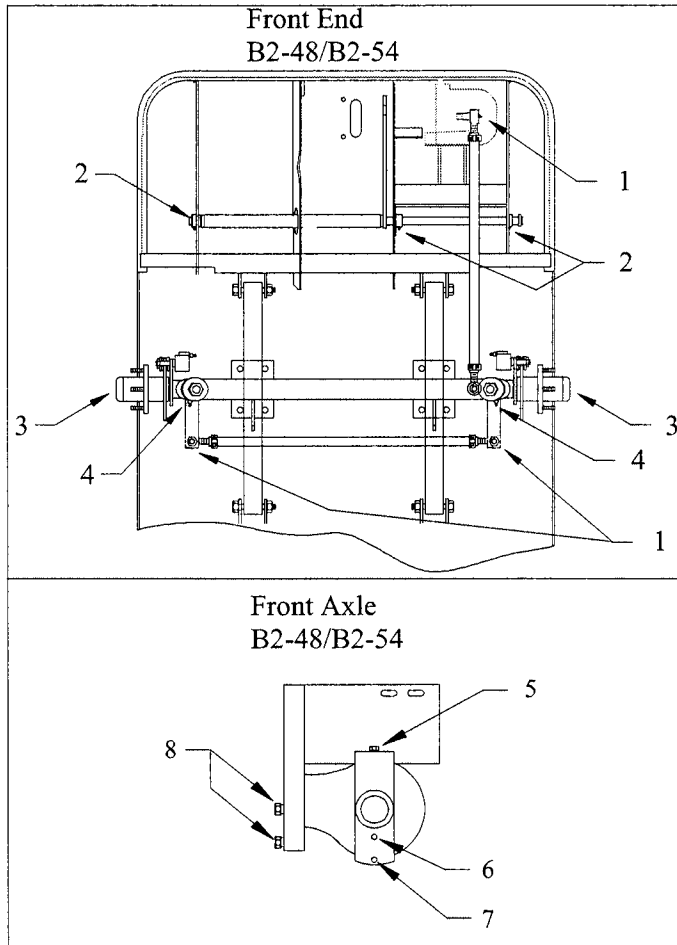

#	Description	Locations	Lubricant Type
1	Steering Ball Joints	4	General Purpose Grease
2	Brake Pedal Linkage	3	General Purpose Grease
3	Front Wheel Bearings	2	High Temperature Bearing Grease
4	King Pin	2	General Purpose Grease
5	Drive Fill Plug	1	SAE 140 API GL-5 Hypoid Gear Oil
6	Drive Level Plug	1	
7	Drive Drain Plug	1	
8	Chain Case Fill Plug	1	SAE 140 API GL-5 Hypoid Gear Oil

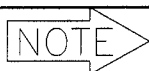

THE LUBRICATION CHART FOR THE B2-38 IS IN SECTION 3A.

TROUBLESHOOTING GUIDE

Symptom	Probable Cause
Steering Pulls in One Direction	Front End Out of Alignment
Hard Steering	Dry Lube Points in Steering Linkage
	Damaged King Pin/Ball Joint
Excessive Steering Play	Worn Ball Joints
	Mis-Adjusted or Worn Steering Gear
	Loose Steering Linkage
Lack of Power or Slow Operation	Brakes or Parking Brakes Dragging
	Worn Drive Gears
	Front End Out of Alignment
	Defective Speed Control
Abnormal Noise	Worn Drive Gears or Bearings
	Worn Front /Rear Axle Bearings
	Loose Lug Nuts
	Motor Bearings Worn
Oil Leak in Rear Bearing Area	Rear Wheel Bearing and/or Gasket Failed
	Drive Over Filled

The page numbers listed in the table above are meant only as a guide to help you find the general information in this manual.

Section 3

Disc Brake

⚠ WARNING

The axle mounting bolts and the brake body bolts can only be used once. If removed they must be replaced.

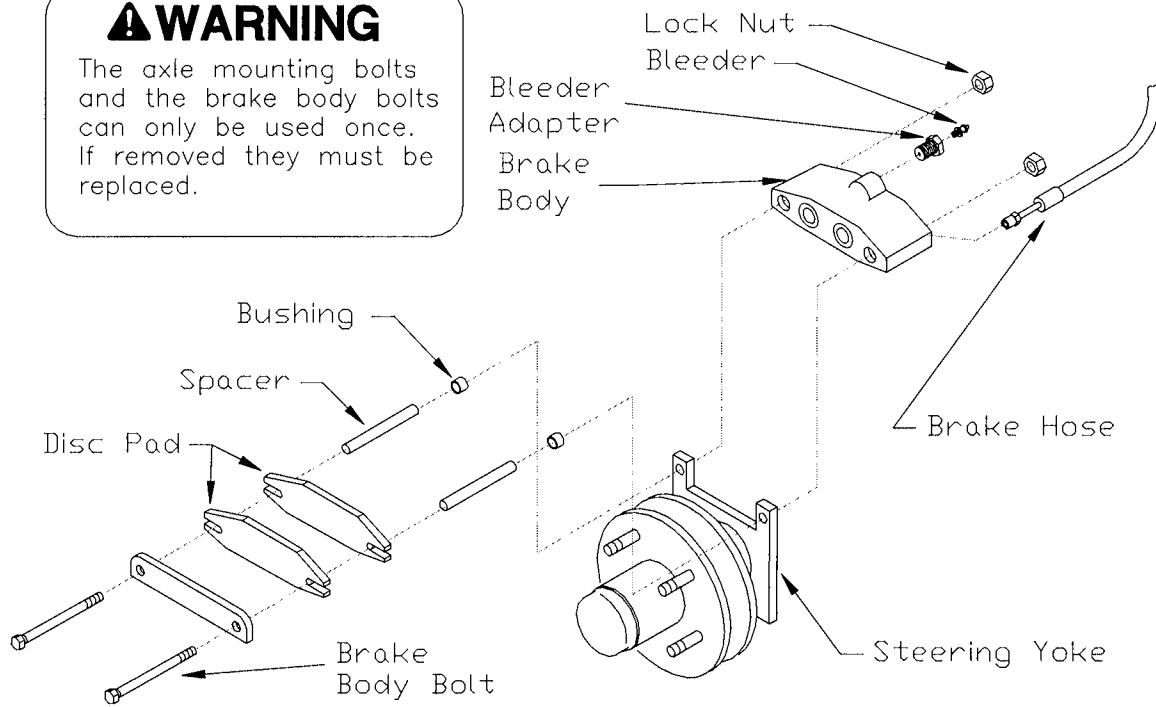

Brakes

The figure on the previous page shows a typical disc brake assembly. The assembly illustrated is a front brake.

B2-48/38:

Rear Hydraulic Disk Brakes (Standard on B2-48 and B2-38)

Front Hydraulic Disc Brakes (Optional on B2-48 Only)

B2-54:

Front and Rear Hydraulic Disk Brakes

Due to the different brake configurations, be sure that you are fully aware of the brake system installed on the vehicle you are working on, before continuing.

⚠ CAUTION

BRAKE FLUID IS CORROSIVE AND WILL DAMAGE PAINTED AREAS. AVOID SPILLING FLUID ON ANY SURFACE

Taylor-Dunn does not currently supply asbestos fiber-brake pads/shoes with any vehicle. However, there is the possibility that the original brake pads/shoes were replaced with aftermarket pads/shoes containing asbestos. Since this possibility does exist, the brake pads/shoes should be handled as if they do contain asbestos.

Never use compressed air or dry brush to clean the brake assemblies. Use an OSHA approved vacuum cleaner or any alternate method approved by OSHA to minimize the hazard caused by airborne asbestos fibers and brake dust.

Do not grind, sand, break, or chisel the brake pads/shoes, as this will cause unnecessary dust, possibly releasing asbestos fibers in the air.

⚠ WARNING

Always wear protective clothing and a respirator when working on the brake pads/shoes or their associated components.

Inhaled asbestos fibers have been found to cause cancer and respiratory diseases.

Do not drive the vehicle if any worn or broken part is detected in any part of the brake system. The cause of the damage must be repaired immediately.

Disc Brakes

The hydraulic disc brakes, available on these vehicles are not adjustable. However, they do need to be periodically inspected, for any possible leaks and to check the wear of the brake pads and, rotors. Follow the procedures below to service these brake systems.



THE BRAKE ROTORS ARE AN INTEGRAL PART OF EACH AXLE. IF THE ROTORS ARE DAMAGED OR WORN, THE AXLE MUST BE REPLACED.

Brake Pads

To remove and replace the brake pads:

1. Place blocks under the wheels to prevent vehicle movement.
2. Disconnect the main positive and negative terminals from the batteries.
3. Raise either the front or rear of the vehicle, (depending on which set of brakes you are working on,) and support the vehicle with jack stands.

▲ WARNING

Always use a lifting strap, hoist, and jack stands, of adequate capacity to lift and support the vehicle. Failure to use lifting and support devices of rated load capacity may result in serious injury.

4. Remove the wheels.
5. Remove the two 1/4" brake body bolts (See Brake Figure 1 Below).

Do not let the brake body hang by the brake hose. Support the brake body to prevent damage to the hose.

6. Inspect the spacers for wear and replace as necessary.

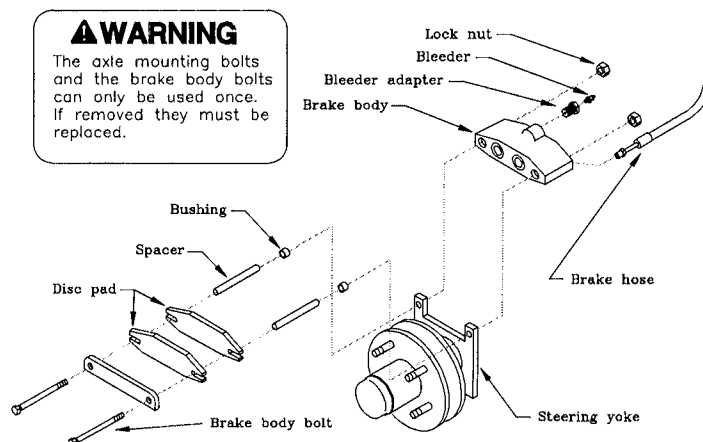

Brake Figure 1: Exploded View of Disc Brake Assembly

7. Replace the spacer bushings in the axle retainer bracket.
8. Replace the brake pads and reassemble the brake to the retainer bracket (*See Brake Figure 1 on the previous page*).

⚠ WARNING

Always use new locknuts and bolts. Locknuts and bolts become less effective if used more than once. If the locknuts or bolts holding the brake to the drive come loose, serious injury may occur.

9. Install new grade 8 locknuts and brake mounting bolts.
10. Tighten the bolts to 11 ft-lbs.
11. Test the brakes to ensure proper installation and braking.

Repairing the Brake Body

1. Remove the brake body. Refer to replacing the brake pads.
2. Carefully remove the two pistons, rubber boots and o-rings.

⚠ WARNING

The pistons are very brittle and break easily

3. Clean and dry the brake body completely.
4. Make sure there are no contaminants left in the brake body.
5. Inspect the interior of the brake body. If any damage or wear is found it must be replaced.
6. Reassemble the brake body using clean DOT 3-brake fluid as a lubricant.
7. Use tool #41-350-13 to install the rubber boots
8. Install the brake body.

⚠ WARNING

The 1/4" gr. 8 locknuts for the brake body bolts must be replaced.

9. Tighten the new retaining bolt lock nuts to 11-ft lbs.
10. Bleed the brakes. (*Refer to "Bleeding the Brakes," on page 3-12.*)
11. Lower and test-drive the vehicle.

Section 3

Bleeding the Brakes

You must bleed the entire hydraulic system to remove any air from the system, after removing brake lines, hoses or the master cylinder. The best way to bleed the brakes is to have one person at the brake pedal, and another person opening and closing the bleeder valve at each wheel.

Before beginning this service or any service read the “**Maintenance Guidelines**,” on page 3-2 and follow each of the bulleted items before continuing.

Make provisions to catch and properly dispose of the brake fluid in the hydraulic brake system.

▲ CAUTION

BRAKE FLUID IS CORROSIVE AND WILL DAMAGE PAINTED AREAS. AVOID SPILLING FLUID ON ANY SURFACE.



YOU SHOULD START THIS PROCEDURE AT THE WHEEL/BRAKE BODY FURTHEST FROM THE MASTER CYLINDER, AND THEN WORK YOUR WAY TO THE WHEEL/BRAKE BODY CLOSEST TO THE MASTER CYLINDER.

To bleed the brake system, follow these procedures:

1. Add DOT-3 brake fluid to the master cylinder. **(If needed.)**
2. Apply pressure to the brake pedal and pump it once or twice, for maximum pedal height.
3. Attach a clear hose to the bleeder valve.

HINT: *The hose should be long enough to reach the bottom of the drip pan.*

4. With a drip pan under the hydraulic brake body. Loosen the bleeder valve on the hydraulic brake body, about 3/4 of a turn.
5. Depress the foot pedal to the floor and tighten the bleeder valve.
6. Slowly release the foot pedal allowing it to return to its released position.
7. Repeat steps four- (4) through six- (6) until the air is expelled from the line.

HINT: *The hose attached to the bleeder valve can be used to check if the air has been expelled from the brake line. Let the end of the hose, rest under the surface of the fluid in the drip pan. When air-bubbles no longer escape from the tube as the pedal is being depressed, then the line is void of air.*

8. Check and add brake fluid to the master cylinder as needed
9. Then repeat this process with each of the other wheels.

▲ CAUTION *Do not allow the fluid level in the master cylinder too get to low, as air may enter the brake lines. Keep the level high by constantly adding fluid*

When finished, top off the master cylinder with fluid to 1/4 from the top of the chamber, replace the cover, and clip on the master cylinder.

Section 3

Replacing the Master Cylinder

Before beginning this service or any service read the “**Maintenance Guidelines**,” on page 3-2 and follow each of the bulleted items before continuing.

Make provisions to catch and properly dispose of the brake fluid in the hydraulic brake system.

Avoid ingesting and/or contact with skin or eyes. Always wear protective clothing and a face shield when working with or around brake fluid.

SKIN CONTACT:

Flush area immediately with water for several minutes.

EYE CONTACT:

Immediately flush the eye with water for fifteen (15) minutes and call physician.

INGESTION:

Induce vomiting immediately and call a physician.

KEEP OUT OF REACH OF CHILDREN.

BRAKE FLUID IS CORROSIVE AND WILL DAMAGE PAINTED AREAS. AVOID SPILLING FLUID ON ANY SURFACE.

⚠ WARNING

1. Place blocks under the rear wheel to prevent vehicle movement.
2. Disconnect the batteries.
3. Support the front of the vehicle with jack stands.

⚠ CAUTION

Always use a lifting strap, hoist, and jack stands, of adequate capacity to lift and support the vehicle. Failure to use lifting and support devices of rated load capacity may result in serious injury.

4. Remove the cap from the master cylinder and, pump all of the brake fluid from the master cylinder and dispose of it properly.
5. Remove the brake line(s) from the master cylinder fitting.
6. While supporting the master cylinder, remove the mounting bolts.
7. Install the new master cylinder in reverse order.
8. Fill the master cylinder with fresh DOT 3 brake fluid 1/4” from the top of the master cylinder.

9. Bleed the brakes and check for leaks.
10. Check the brake fluid level again and fill as needed.
11. Test drive.

**Brake Figure 3a: B 2-48/B2-38
Master Cylinder**

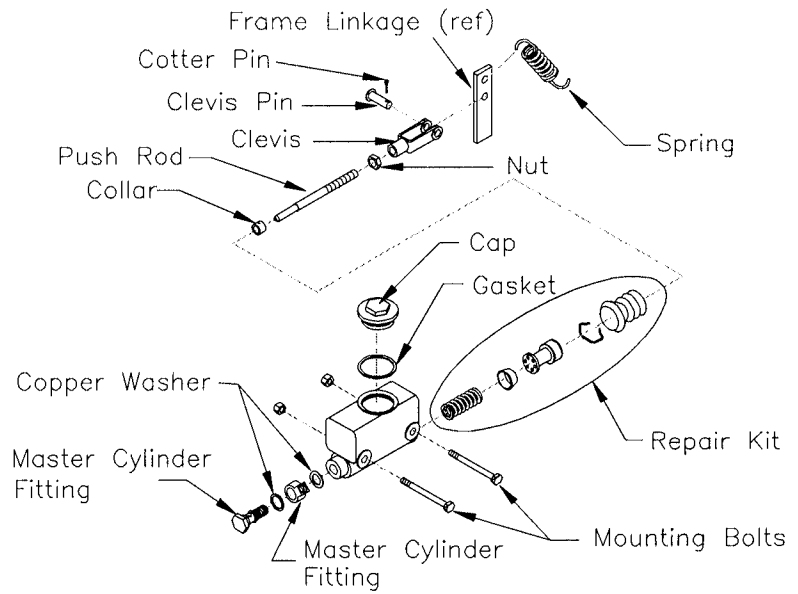

**Brake Figure 3b: B 2-54 Master
Cylinder**

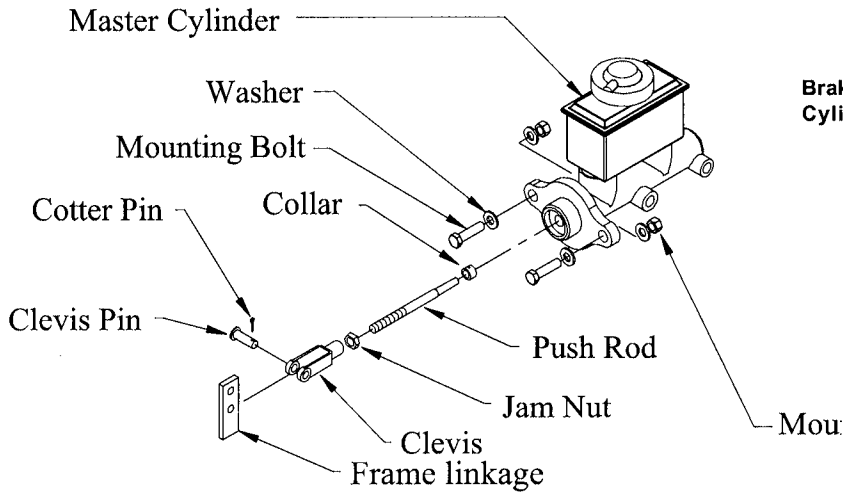

Section 3

Filling and Checking the Fluid Level

To fill check the brake fluid-level follow these procedures:

1. Clean the cover and exterior of the master cylinder and the surrounding area.
2. Remove the cap from the top of the master cylinder and visually check the level of fluid in the master cylinder.



THE FLUID SHOULD BE AT THE BOTTOM OF THE THREADS ON THE MASTER CYLINDER OPENING DO NOT FILL THE MASTER CYLINDER PAST THIS POINT AS IT WILL RESULT IN LEAKS.

3. Add DOT 3 Brake Fluid as needed and replace the cap on the master cylinder.

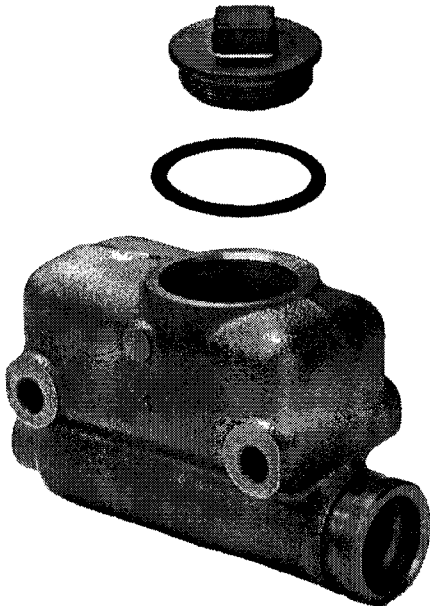

Brake Figure 4a: B2-38/B2-48 Master Cylinder

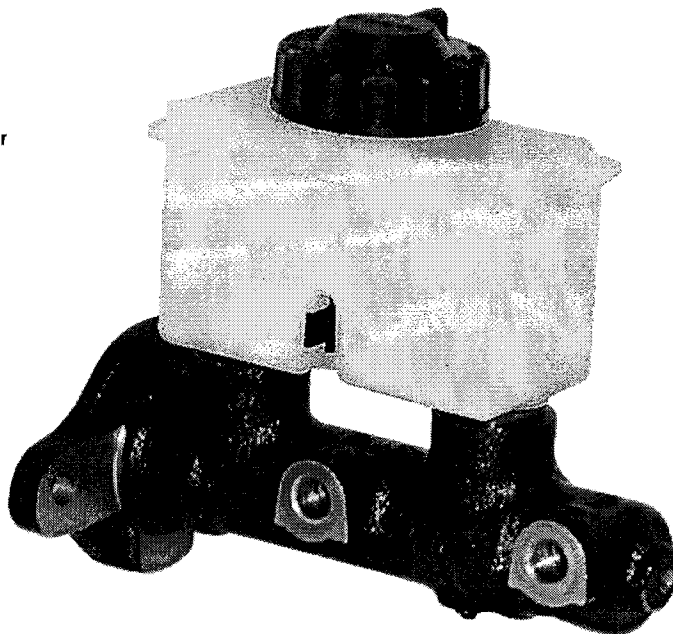

Brake Figure 4b: B2-54 Master Cylinder

Parking Brake

To adjust the parking brake follow these procedures.



THERE ARE TWO ADJUSTMENTS TO BE PERFORMED ON THE PARKING BRAKE. BE SURE TO READ THE PROCEDURE BELOW AND ON THE FOLLOWING PAGE.

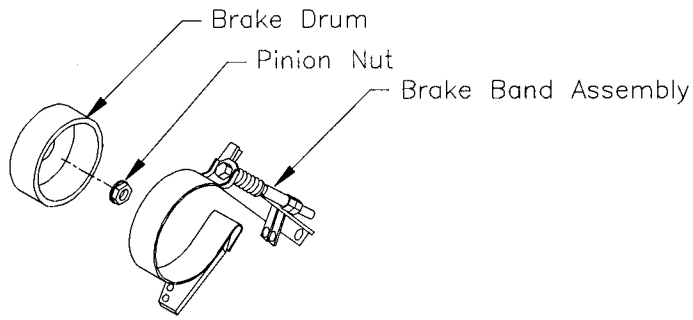

Park Brake Figure 1: Park Brake Assembly

Primary Adjustment

1. Block the wheels.
2. Release the parking brake handle.
3. Turn the grip on the top of the brake handle clockwise.
4. Set the park brake again and check to see if it holds.
5. Test drive the vehicle to be sure that the brake does not drag.
6. Adjust the brake handle as needed, and test drive again.
7. Repeat the steps above until the brake holds and does not drag while released.

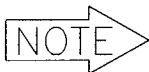

IF THE BRAKE WILL NOT HOLD OR IT DRAGS, INSPECT THE BRAKE BAND AND DRUM FOR WEAR OR DAMAGE AND REPLACE THEM AS NEEDED.

Section 3

Secondary Adjustment

1. Block the wheels.
2. Release the parking brake handle.
3. Turn the top of the brake handle counterclockwise until the brake is loose.
4. Loosen the jam nut on the brake adjusting bolt.
5. Tighten the brake adjusting bolt lock nut.
6. Test drive the vehicle and check for dragging.
7. After the final adjustments are complete tighten the jam nut.

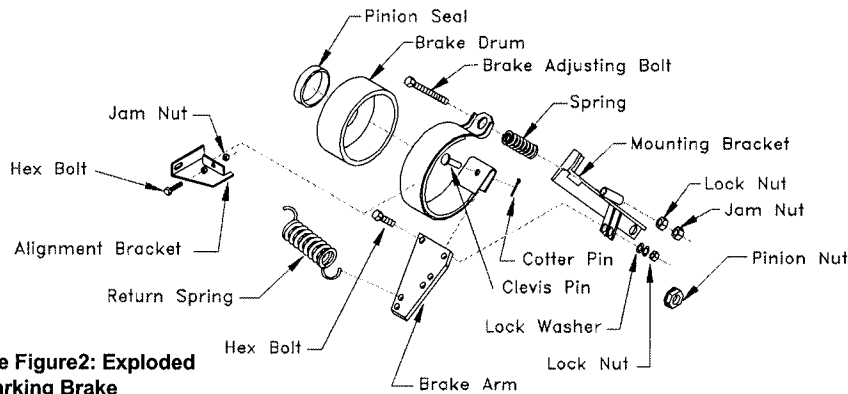

**Park Brake Figure2: Exploded
View of Parking Brake**



IF THE BRAKE BAND DRAGS ON THE DRUM BACK OFF THE BRAKE ADJUSTING BOLT UNTIL THE DRAGGING IS ELIMINATED.

Wear Limit

The brake band should be replaced when the pad wears to a thickness of less than 1/16".

Front Axle and Steering

Axle Removal B2-48

⚠ CAUTION BRAKE FLUID IS CORROSIVE AND WILL DAMAGE PAINTED AREAS. AVOID SPILLING FLUID ON ANY SURFACE.

1. Disconnect the batteries.
2. Lift the front end and support with jack stands.
3. Block the rear wheels to prevent the truck from rolling.
4. Remove both front wheels.
5. Disconnect the brake hoses from the disc brake bodies (if equipped).

⚠ CAUTION Brake fluid will drip from the open brake lines.

6. Remove the drag link from the left (driver) side steering yoke.
7. Remove the u-bolts holding the axle to the springs.

⚠ CAUTION Support the axle with additional stands or tie it up to the frame to prevent it from falling.

8. Remove the bolts from the rear front spring-hangers.
9. Remove the axle from the truck.

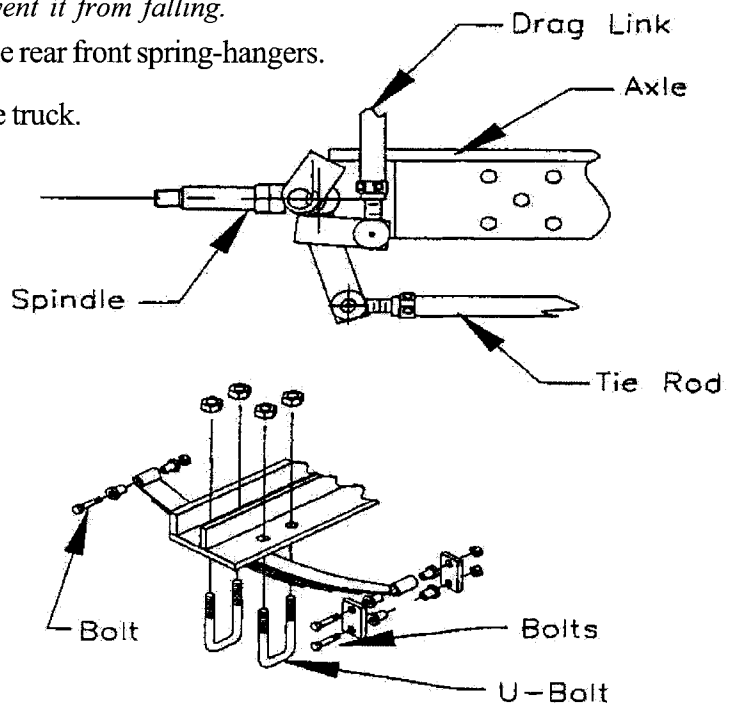

Section 3

Axle Installation B2-48

1. Install in reverse order.
2. Tighten spring hanger snugly but still allowing the spring to pivot.
3. Tighten the drag link ball joint to 40-45 ft. lbs.
4. Bleed the front brakes and check for leaks.

Axle Removal B 2-54

1. Disconnect the batteries.
2. Lift the front end and support with jack stands.
3. Block the rear wheels to prevent the truck from rolling.
4. Remove both front wheels.
5. Disconnect the brake hoses from the disc brake bodies.

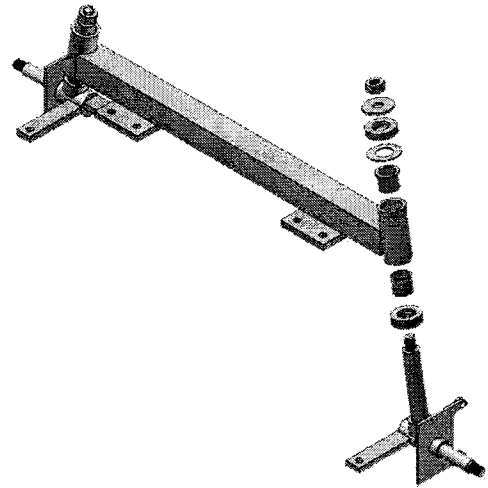

B2-54 Front Axle

⚠ CAUTION *Brake fluid will drip from the open brake lines.*

6. Raise the front of the vehicle and support with jack stands.
7. Remove the drag link from the steering yoke.
8. Remove the bolts holding the leaf springs to the frame.

⚠ CAUTION *Support the axle with additional stands.*

⚠ CAUTION *BRAKE FLUID IS CORROSIVE AND WILL DAMAGE PAINTED AREAS. AVOID SPILLING FLUID ON ANY SURFACE.*

9. Remove the axle with the leaf springs from the vehicle.
10. Install in reverse order.



IF THE LEAF SPRINGS WERE REMOVED FROM THE AXLE, BE SURE TO LEAVE THE U-BOLTS LOOSE UNTIL THE AXLE IS MOUNTED TO THE FRAME.

11. Bleed the brakes using the appropriate procedure.
12. Lower the vehicle.
13. Reconnect the main positive and negative cables at the batteries.
14. Remove the blocks from behind the wheels.
15. Release the park brake and test drive the vehicle.

Aligning the Front End B2-48/B2-54



CASTER AND CAMBER ARE SET AT THE FACTORY AND DO NOT REQUIRE ADJUSTMENT.

1. Raise the front end of the vehicle and support with jack stands.
2. Center the steering. (Refer to the Figure on the next page.)
3. With a piece of chalk, mark a line around the center of both tires by holding the chalk against the tire while turning the wheel.
4. Loosen the ball joint clamps at each end of the tie rod so the adjusting sleeve can be turned.
5. Lower front end back on the ground.
6. With the wheels in the straightforward direction measure the distance between chalk lines at the front and the rear of the tires.
7. Adjust the tie rod sleeve until the distance from mark to mark across the front of the tires is the same as the distance from mark to mark across the rear.
8. Tighten the ball-joint clamp nuts securely.

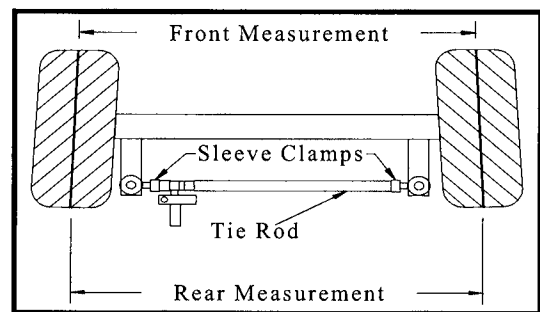

Section 3

Centering the Steering B2-48/B2-54

1. Remove the pitman arm from the steering gear.
2. Align the front wheels straight ahead and tie or clamp in position.
3. Center the steering gear.
 - a.) Turn the gear all the way to the left.
 - b.) Turn back three turns, and tie it off so it can not move.
4. Install the pitman arm while keeping the front wheels in the straight-ahead position. Tighten nut to 70-ft lbs.
5. Remove and center the steering wheel on the steering shaft while keeping the front wheels in the straight-ahead position.
6. Install the steering wheel nut and cap.

Repairing the Front Axle B2-48/B2-54

Steering Yoke/Bushings B2-48/B2-54

1. Remove the bearing cap, spindle nut and the wheel/hub assembly.



CATCH THE OUTER BEARING AS IT FALLS OUT.



REMOVE THE DRAG LINK AND TIE ROD FROM THE YOKE (ONLY IF THE YOKE IS TO BE REPLACED).

2. Remove the kingpin nut.
3. Remove the yoke from the axle.
4. Clean and replace as necessary, bearings, and bushings, thrust bearing.

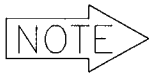
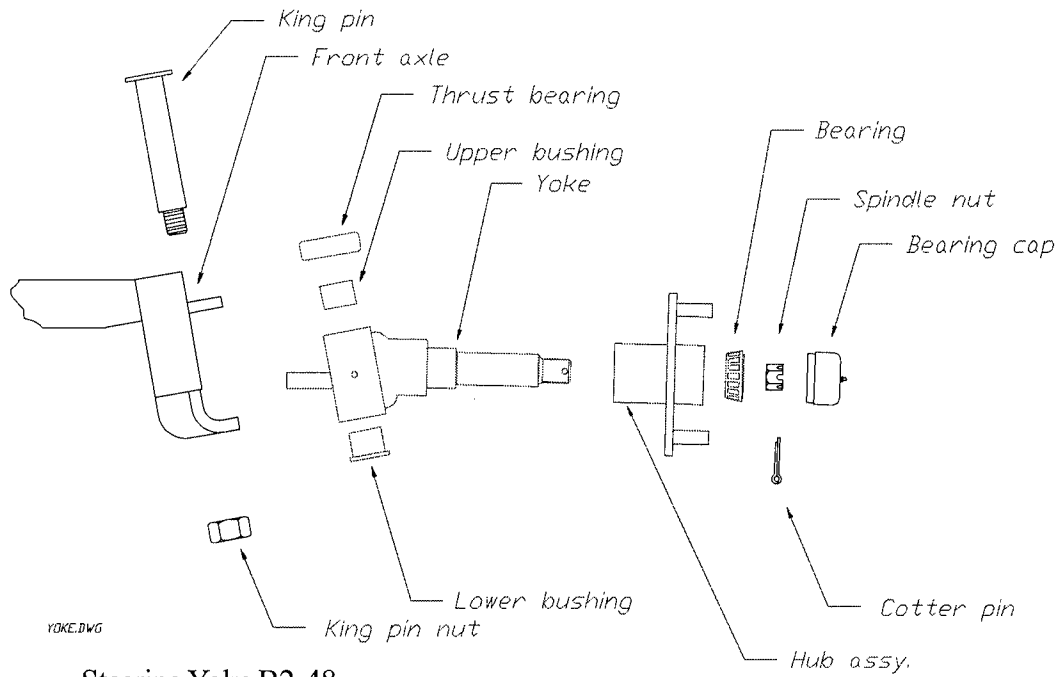

IF THE BUSHINGS ARE REPLACED, THEY MUST BROACHED OR REAMED TO THE FOLLOWING SIZE AFTER THEY ARE PRESSED INTO THE YOKE:

B2-48: 0.880 +0/-0.001

B2-54: 1.254 +/-0.001

5. Install in reverse order.
6. Clean and pack the thrust bearing with grease.

CAUTION *The thrust bearing must be orientated correctly.*

7. Tighten the kingpin nut.
8. Tighten the drag link ball joint nut (if it was removed) to 40-45 ft. lbs. Use a NEW cotter pin.
9. Install the front wheel.
10. Tighten spindle nut to 30-ft. lbs. to seat bearings.
11. Back off spindle nut until the hub turns, but is not loose. Then install a NEW cotter pin.
12. Install the bearing cap.

Section 3

Wheel Bearings B2-48/B2-54

1. Remove the tire/wheel assembly
2. Remove the bearing cap and spindle nut.
3. Remove the hub from the spindle.



CATCH THE OUTER BEARING AS IT FALLS OUT

4. Clean all grease from the inside of the hub and bearings.
5. Inspect and replace the races and bearings as a set.

▲ CAUTION

It is recommended to replace both the left and right wheel bearings at the same time.

6. Assemble in reverse order, using new grease seals.
 - a.) Pack inner and outer bearings with grease.
 - b.) Tighten the spindle nut to 30-ft. lbs. while rotating the hub to seat bearings.
 - c.) Back off spindle nut until the hub turns, but is not loose. Then install a new cotter pin.
7. Install the bearing cap.

Ball Joints B2-48/B2-54



IT IS RECOMMENDED TO REPLACE ALL THE BALL JOINTS AS A SET.

1. Loosen the ball joint clamp. Note its position on the sleeve.
2. Remove the ball joint nut, and then remove the ball joint using a pickle fork.
3. Count the number of turns while removing the ball joint from the drag link or tie rod.
4. Lightly lubricate the threads on the new ball joint and install into the drag link or tie rod counting the same number of turns as when removed.
5. Install the ball joint into the steering arm and tighten nut to 40-45 ft, lbs. Use a NEW cotter pin.
6. Lube the new ball joint.
7. Realign the front wheels.
8. Tighten the ball joint clamps securely.

▲ CAUTION

Make sure the clamps are in their original position noted in step 1. Turn the steering all the way from left to right to make sure there is no interference.

Section 3

Steering Gear Adjustment B2-48/B2-54

Endplay

1. Loosen the input shaft bearing adjustment jam nut.
2. Tighten the adjusting nut so that there is no endplay or wobble in the input shaft.
3. Tighten the jam nut.

Gear Lash

1. Remove the pitman arm. Note its position.
2. Loosen the jam nut for the gear lash set screw.
3. Tighten the setscrew so that there is a slight drag when the steering gear passes through the center of its travel (about three- (3) turns from lock).
4. Tighten the jam nut. Do not allow the setscrew to turn while tightening.
5. Install the pitman arm in its original position. Tighten to 70-ft. lbs.

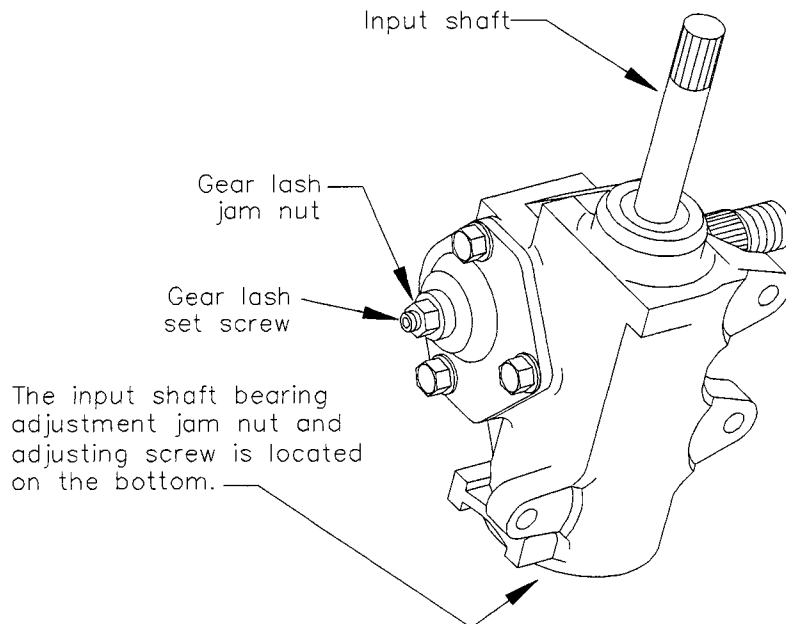

Steering Figure 2: Steering Gear

Drive Axle

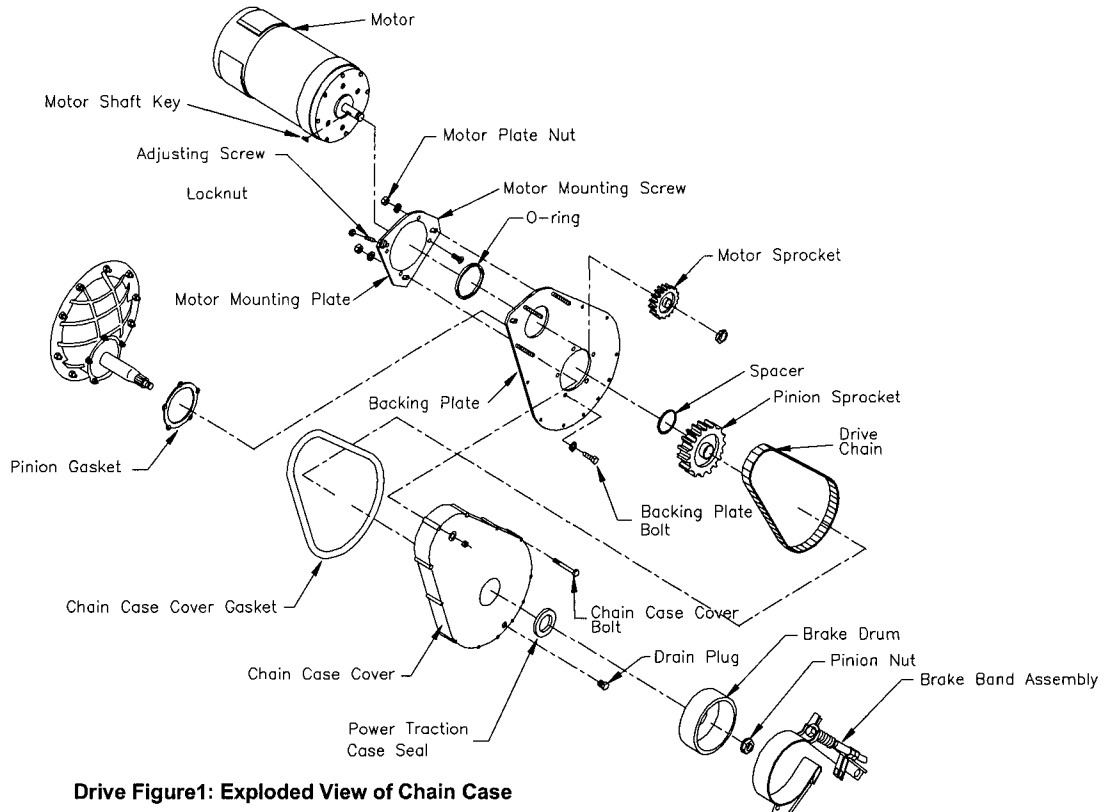

Drive Figure1: Exploded View of Chain Case

Drive Chain Adjustments

1. Disconnect the main positive and negative battery cables, from the battery.
2. Set the park brake.
3. Place a drip pan under the chain case to catch any oil that may spill.
4. Loosen the three-(3) motor mounting plate nuts to let the motor mounting plate move freely.
5. Loosen the chain adjusting screw jam nut.
6. Turn the chain adjusting screw so the the ends of the motor fan blades have 1/8" to 1/4" of free play.
7. Tighten the three motor mounting plate nuts.
8. Tighten the adjusting screw jam nut while preventing the adjusting screw from turning.
9. Reconnect the main battery leads.



IF THE DISTANCE BETWEEN THE END OF THE ADJUSTING SCREW AND THE TOP OF THE JAM NUT IS 1/16" OR LESS IT IS TIME TO ADJUST THE CHAIN. FOR THE CHAIN ADJUSTMENT SCHEDULE REFER TO THE TALBE ON PAGE 26.

Chain Adjustment Schedule	
Interval	Period
First	100 Hours
Second	200 Hours
Following	Every 400 Hours

Chain Adjustment Schedule Table

Motor Removal

1. Disconnect the batteries.
2. Disconnect all power leads to the motor.
3. Support the motor with a hoist and strap of sufficient capacity.
4. Remove the chain case adjusting screw.
5. Remove the three-(3) motor mounting nuts and washers.
6. Remove the motor by lifting the back end of the motor and rotating it counterclockwise, which will move the adjusting tab off the flat on the chain case plate. The motor with the mounting plate attached should be able to slide out from under the chain.

CAUTION

Do not move the vehicle at this time as this may cause the chain to become jammed inside the chain case cover.

Motor Installation

1. Clean all mounting surfaces on the motor and mounting plates.
2. Apply grease to the o-ring and backing plate.
3. Make sure the o-ring is seated in the motor mounting plate correctly.
4. With a wire formed in to a hook, tie the chain up to the upper slot on the backing plate.
5. Install the motor on to the chain case backing plate and slip the sprocket under the chain.



THE CHAIN MUST BE PROPERLY SEATED ON THE LARGE SPROCKET FOR THE PROPER INSTALLATION OF THE MOTOR SPROCKET.

5. Install the mounting nut holding the motor mounting plate and motor to the chain case backing plate and leave loose.

6. With the chain loosely on the upper sprocket, remove any wire used to support the chain.

▲ CAUTION *Do not allow the wire to break. If the wire breaks, the chain case must be disassembled to retrieve it.*

7. Move the vehicle slightly. The motor armature should rotate. If the armature does not rotate, then the chain is not seated properly.



IF THIS OCCURS TRY REMOVING THE MOTOR AGAIN JUST AS STATED IN PREVIOUS PROCEDURE, "MOTOR REMOVAL," AND THEN REPEAT STEPS ONE-(1) THROUGH SEVEN-(7) OF THIS PROCEDURE.

8. Install the remaining hardware onto the mounting studs, finger tight.
9. Adjust the chain tension and described in "Drive Chain Adjustment."

Power Traction

Removing the Power Traction Assembly

1. Disconnect the batteries.
2. Remove the drain plug and drain the oil from the chain case.
3. Remove the brake band assembly and drum.
4. Remove the pinion nut and brake drum from the pinion shaft.
5. Remove the remaining bolts and nuts holding the cover to the backing plate, and remove the chain case cover.
6. Loosen the chain adjusting screw completely.
7. Remove the chain, pinion sprocket, and spacers from the pinion shaft.



BEFORE REMOVING THE SPACERS FROM THE PINION SHAFT TAKE CAREFUL NOTE OF THEIR LOCATIONS AND POSITION FOR REASSEMBLY.

8. Remove the chain from the motor sprocket and remove the motor.
9. Inspect and replace the chain and sprockets as needed.
10. Reassemble the power traction assembly in reverse order, installing new gaskets and seals. Use the centering tool (TAYLOR-DUNN Part Number 41-532-50,) to center the power traction case seal on the chain case cover.



IF THE POWER TRACTION CASE SEAL IS NOT CENTERED CORRECTLY, OIL WILL LEAK ON TO THE PARKING BRAKE.

While reassembling the power traction assembly be sure to torque the pinion nut to 175 ft-lbs. and all of the chain case cover mounting bolts to 20 ft-lbs.

After you have reassembled the power traction assembly adjust the drive chain as described in "Drive Chain Adjustment," on page 23.

11. Fill the chain case with oil.
12. Test drive.

Differential Service and Repair



IT IS NOT NECESSARY TO REMOVE THE ENTIRE DRIVE ASSEMBLY TO PERFORM THIS PROCEDURE.

1. Raise the drive wheels and support the vehicle with jack stands.
2. Drain the oil from the power traction chain case and drive.
3. Remove the motor and power traction assemblies.
4. Remove the rear wheels and brakes.
5. Using a slide hammer, slide the axles out from the drive housing .
6. Remove the third member mounting nuts and third member from the housing.
7. Remove the carrier bearing flanges and the carrier assembly from the housing.
8. Remove the pinion housing assembly from the third member.

CAUTION *Do not lose shims !*

9. Replace bearings, bearing races, and gears as needed.

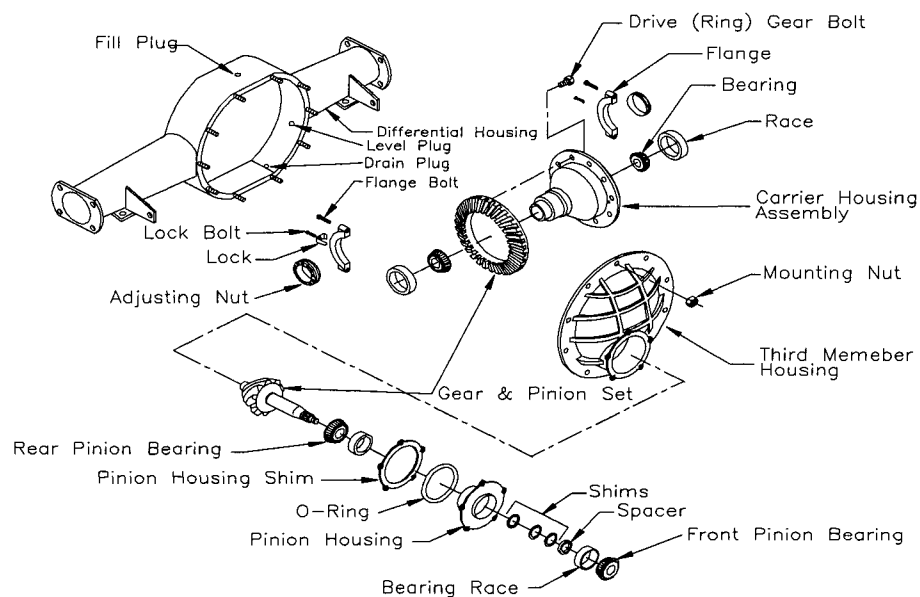

Drive Figure 2: Exploded View of 3rd Member

10. Read the following list of things to remember while reassembling the differential and then reassemble it in reverse order.
 - a.) Pre-lube all bearings and gears during reassembly.
 - b.) Cross tighten ring gear bolts to 72 ft-lbs.
 - c.) If pinion bearing or gears are replaced, the drive must be reshimmed.(See Re-Shimming the Pinion Bearings, below.)
 - d.) Use new seals.

Adjust the Backlash

1. Install the correctly shimmed pinion gear and pinion gear housing
2. Temporarily install the drive sprocket and brake drum. Torque the pinion nut to 100 ft-lbs.
3. Tighten the carrier bearing cap bolts to 15 ft-lbs.
4. Position the carrier assembly against the pinion gear and turn the adjusting nuts to contact the carrier bearings.
5. Loosen the adjusting nut on the toothed side of the ring gear slightly.
6. Tighten the other nut so that there is no gear backlash, but so tight to cause binding.
7. Tighten the adjusting nut on the toothed side of the ring gear so that there is .008 to .012 backlash.
8. Tighten the carrier bearing cap bolts to 40-55 ft-lbs.

Re-Shimming the Pinion Bearings

1. Remove the pinion housing from the third member.
2. Install the drive gear and brake drum (or equivalent spacer,) on to the pinion shaft and tighten to 100 ft-lbs.
3. The pinion gear should turn freely with zero radial play.



DO NOT ROTATE BEARINGS WHEN DRY, THEY MUST HAVE A LUBRICANT, OR THEY WILL BE DAMAGED.

4. Add or remove shims as necessary.

Selecting Pinion Housing Shims

The pinion housing shims are available in thickness' from 0.005" to 0.021", in increments of 0.001", to correctly position the pinion gear. However, the standard shim thickness is 0.015" thick.

The following numbering system is used on pinions to indicate the amount you must add or subtract from the standard shim, in order to correctly position the pinion gear. Locate the number on the flat surface on the small shaft at the end of the pinion gear. Match the number with the shim required. Refer to the table below:

Pinion Numbering System	
If the number is	Add Shim as Follows
+0	No Adjustment
+1	Add .001 Shim
+2	Add .002 Shim
+3	Add .003 Shim
+4	Add .004 Shim
+5	Add .005 Shim
-1	Subtract .001 Shim
-2	Subtract .002 Shim
-3	Subtract .003 Shim
-4	Subtract .004 Shim
-5	Subtract .005 Shim

Changing the Differential Oil

1. Place a three-(3) quart or larger drain pan under the drive.
2. Remove the differential and chain case drain plugs.
3. Replace the drain plugs and remove the differential fill and level plugs.
4. Install oil into the differential through the filler hole until the oil starts to come out of the level hole. (This usually about two-(2) quarts.)
5. Install the level plug.
6. Add an additional 1/2 quart into the differential fill hole for the chain case. This oil will be pumped in from the differential.
7. Install the remaining plugs.

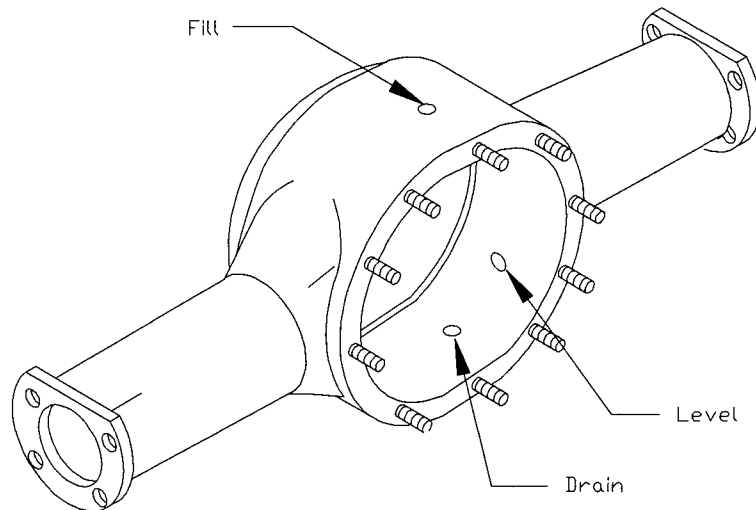

GENERIC FILL AND DRAIN PLUGS ON DIFF.DWG

Rear Axle and Bearing Replacement

1. Raise the drive wheels and support with jack stands
2. Remove the rear wheel.
3. Remove the brake assembly.

⚠ CAUTION Do not let the brake assembly hang by the brake hose.

4. Using a slide hammer, remove the axle from the housing.
5. Press the retainer ring and bearing from the axle shaft, if needed.
6. Press a new bearing and retainer ring onto the axle.

⚠ WARNING Do not reuse the old bearing retainer

7. Remove and replace the oil seal and/or gaskets from the housing.
8. Install in reverse order.
9. Use new locking tabs on brake bolts.
10. Tighten the brake bolts to 35-40 ft. lbs.

⚠ WARNING Failure to properly bend up the locking tabs could cause the mounting bolts to loosen and result in brake failure.

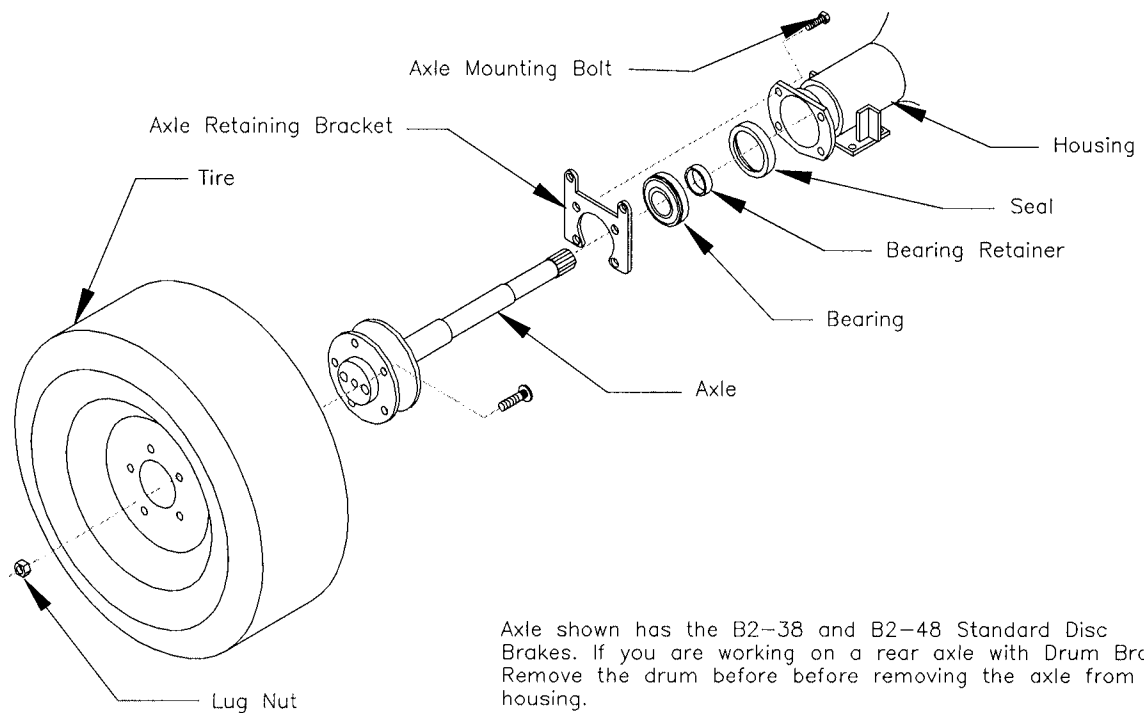

Axle shown has the B2-38 and B2-48 Standard Disc Brakes. If you are working on a rear axle with Drum Brakes. Remove the drum before removing the axle from the housing.

Section 3

Drive Motor

Motor Disassembly

1. Remove the motor from the chain case.
2. Remove the key(s) from the shaft(s).
3. Remove the front bell housing.
4. Pull the armature out from the motor housing.
5. Remove the rear bell housing.

Replacing the Brushes

1. Remove the Brush covers.
2. Remove the brush wire from the brush holder.
3. Pull the brush straight out from the brush holder.



HOLD THE SPRING SO IT DOES NOT SNAP BACK DOWN INTO THE HOLDER.

4. Install in reverse order.



70-055-00 AND 70-054-00 MOTOR-MINIMUM BRUSH SERVICE LENGTH IS .75".
70-057-10 MOTOR-MINIMUM BRUSH SERVICE LENGTH IS .80".
IT IS RECOMMENDED TO REPLACE THE BRUSHES AS A SET.

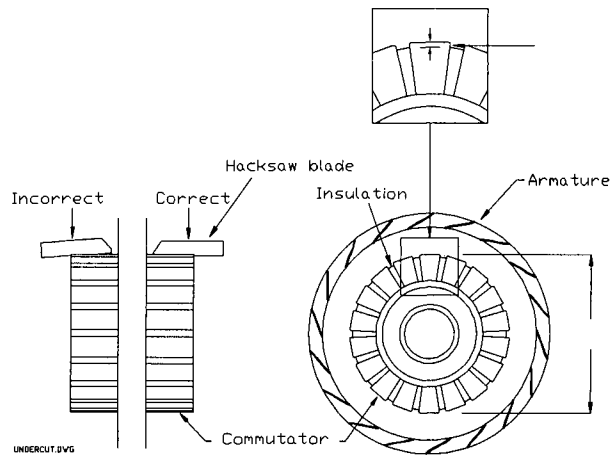



Drive Motor Figure 1

Inspecting the Armature

1. If any solder has been thrown from the armature the motor must be replaced.



CHECK THE INSIDE OF THE MOTOR HOUSING AROUND THE COMMUTATOR FOR BITS OF SOLDER.

2. If the commutator is grooved it must be cut on a lathe.
3. Measure the undercut on the commutator.
 - a.)  If less than .025" then the mica must be undercut. *See Drive Motor Figure 1 on the previous page.*
4. Measure the commutator diameter.
 - a.)  70-055-00 or 70-054-00 MOTOR-If less than 3.109" then the armature is worn out and the motor must be replaced. 70-057-10 MOTOR If less than 2.625" then the armature is worn out and the motor must be replaced.
5. Spin the bearings by hand.
 - a.)  If any vibration or roughness is felt, they must be replaced.

HINT: It will require a press to replace the bearings.

Section 3

Battery

⚠ WARNING

Battery electrolyte is poisonous and dangerous. It contains sulfuric acid. Avoid contact with skin eyes or clothing. Wear rubber gloves and safety glasses while servicing batteries. DO NOT INGEST!

⚠ WARNING

Batteries produce an explosive gas when charging. DO NOT SMOKE, produce an open flame or spark while checking or servicing a battery.

Cleaning

1. Dry dirt can be readily blown off with low-pressure air or brushed off.
2. Wetness or wet dirt on the covers indicates battery acid. Using a nonmetallic brush with flexible bristles wash it off with a strong solution of baking soda and hot water (1 lb. of soda to gallon of water). Continue until all fizzling stops, which indicates that the acid has been neutralized. Then rinse thoroughly with clear water. DO NOT get any of the solution into the battery cells.

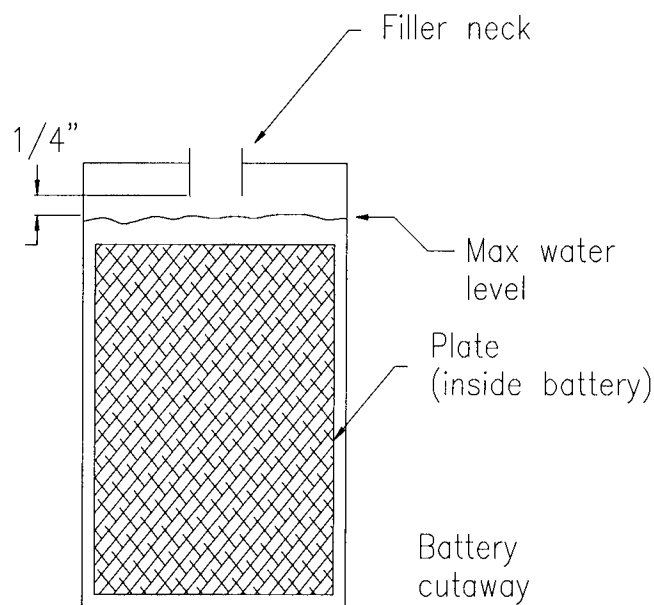

Battery Figure 1: Electrolyte Level

Servicing

1. Check the electrolyte level in all batteries. If low fill with distilled water up to the correct level (*See Battery Figure 1: Electrolyte Level on the previous page*).

⚠ CAUTION *Do not overfill the battery. An overfilled battery may leak acid.*

2. Clean the battery (*See Battery Cleaning on the previous page*.)
3. Clean the cell posts connectors and battery box with water.

Charging

⚠ WARNING *Explosive mixtures of Hydrogen gas are present within battery cells at all times. Do not work with or charge battery in an area where open flames (including gas furnace or water heater pilots), sparks, cigarettes, or any other sources of combustion are present. Always provide ample ventilation in rooms where batteries are being charged.*

To charge the batteries do the following:

1. Check the electrolyte level. If low, fill with distilled water up to the correct level (see diagram).
2. Park the vehicle in an approved area for charging and plug the charger in.
3. Allow the charger to cycle completely before unplugging.

Section 3
Battery Storage

The following pointers will help extend the life of the battery when storing your vehicle for the winter season:

- Clean and check the electrolyte level and charge level of the battery. Do not store a battery low in electrolyte or in a low state of charge.
- Recharge a battery not in use every 1 to 2 months.
- If possible, store the vehicle in a cool dry place.

If the batteries are removed from the vehicle, do not place them directly on the ground, concrete or solid metal surface. It is recommended to store them on a wooden pallet or equivalent.

Battery Figure 2: Battery Configuration

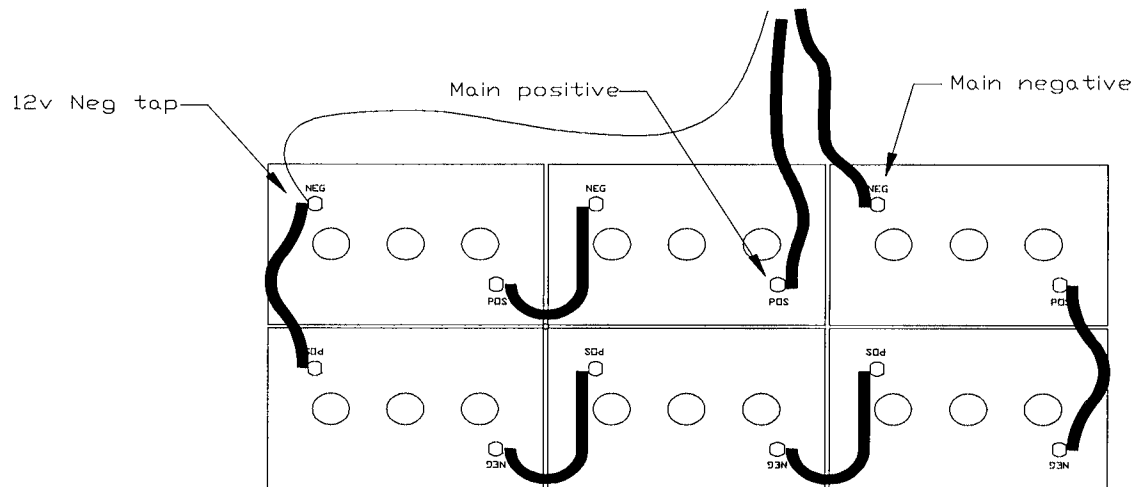

Tires

Servicing the Tires

The B 2-54 is equipped with solid-extra cushion tires (standard). There is no need to check the air pressure on these tires. If your truck has special order pneumatic tires, refer to the sidewall on the tire for the correct air pressure. Air pressure should be checked every 20 hours.

1. Check the tires for nicks or grooves and replace if necessary.
2. Ensure that the tire is properly seated on the rim.
3. Check wheel nuts for tightness.

The B2-48 and B2-38 are equipped with 5.70 X 8 load range B tires (standard). These tires should be checked as follows:

1. Check the tires for nicks or grooves and replace if necessary.
2. Ensure that the tire is properly seated on the rim.
3. Check wheel nuts for tightness.
4. Check the air pressure in the tires. Inflate them as needed to the specified pressure.



REFER TO THE CHART BELOW TO DETERMINE CORRECT TIRE PRESSURE.

Tire Pressure Chart						
Tire Size	Type	Part Number	Load Range	Ply Rating	PSI (MAX)	MAX. Load/Tire (lbs.)
5.70 X 8	Highway Tread	10-081-00	B	4	50	715
18 X 8.5 X 8	Highway Tread	10-093-00	B	4	35	770

Lubrication

Here we will cover where and how often to lubricate the vehicle. To help identify all the lubrication points on these vehicles pages 3-4 and Supplement page S-4 have been duplicated on the pages 42 and 43. These two diagrams will help you locate all of the lubrication point on the B2-48, B2-45, and B2-38.

We have combined the lubrication of all these vehicles in this one location in an effort to put as much common information about these vehicles in one easy to find location as possible. If at anytime a procedure is to be performed on one or any combination of vehicles, the procedure title will reflect this. For instance, if a procedure can only be done on a B2-48. Then the procedure title would be, "Procedure for B2-48", or if it could be done only on the B2-48 and B2-54 but not the B2-38, it would be, "Procedure for B2-48 and B2-54." If the procedure can be carried out on all three of the models then no reference will be made to the model number in the procedure title.

Before beginning this or any service procedure review the "Maintenance Guidelines," on page 3-2 of this manual. Be sure to follow all safety instructions, cautions, and warnings. Always wear safety goggles or glasses when working on or around the vehicles.

Make arrangements to collect and dispose of all discarded, oil, grease, oil soaked rags, grease covered rags or any other material which may used to collect or clean up lubricating oil or grease.

Frequency of Lubrication

These vehicles must be lubricated on a set schedule for them to function properly and to extend their life span. The table on page 3-3 of this manual will give you an excellent guide to follow for doing this. However if the vehicle is used or operated in an extreme environment this schedule will have to be adjusted accordingly. For instance if the vehicle is operated on a daily basis in a location where it is constantly climbing inclines or ran over rough surfaces than the scheduled should be doubled. In other words if the vehicle is operated in this type of environment, then all of the maintenance items should be done twice as often. If it says on the table to perform an operation every 20 hours then it should be done every 10 hours in these conditions.

Lubricate all Zerk Fittings

Refer first to the diagrams showing the locations of the zerk fittings on the vehicles. Then starting at the front of the vehicle work your way around the vehicle applying grease to each of the zerk fittings. This procedure should be carried out every month or every 80 hours which ever occurs first.

Rear Axle Oil

The rear axle oil level is to be checked every 6 months or 500 hours which ever occurs first. It should also be changed once every year or every 1000 hours which ever occurs first.

Regardless of the vehicle you are working on you can refer to 5 through 7 on the B2-48 / B2-54 diagram for the location of the fill, level and drain plugs on the drive.

Clean and Repack B2-48 and B2-54 Front Wheel Bearings

The front wheel bearings should be cleaned and repacked at least once every year or 1000 hours which ever occurs first. Before removing the front wheels for this service be sure to immobilize the vehicle and refer to the **Maintenance Guidelines** in section 3.

B2-38 Front Wheel and Fork Bearings

These bearings should be lubricated on the same schedule as the B2-48 and B2-54 wheel bearings, once a year or 1000 hours, which ever occurs first. However the B2-38's bearings are lubricated by the use of the zerk fittings located on the front fork.

Section 3

LUBRICATION DIAGRAM FOR B2-38

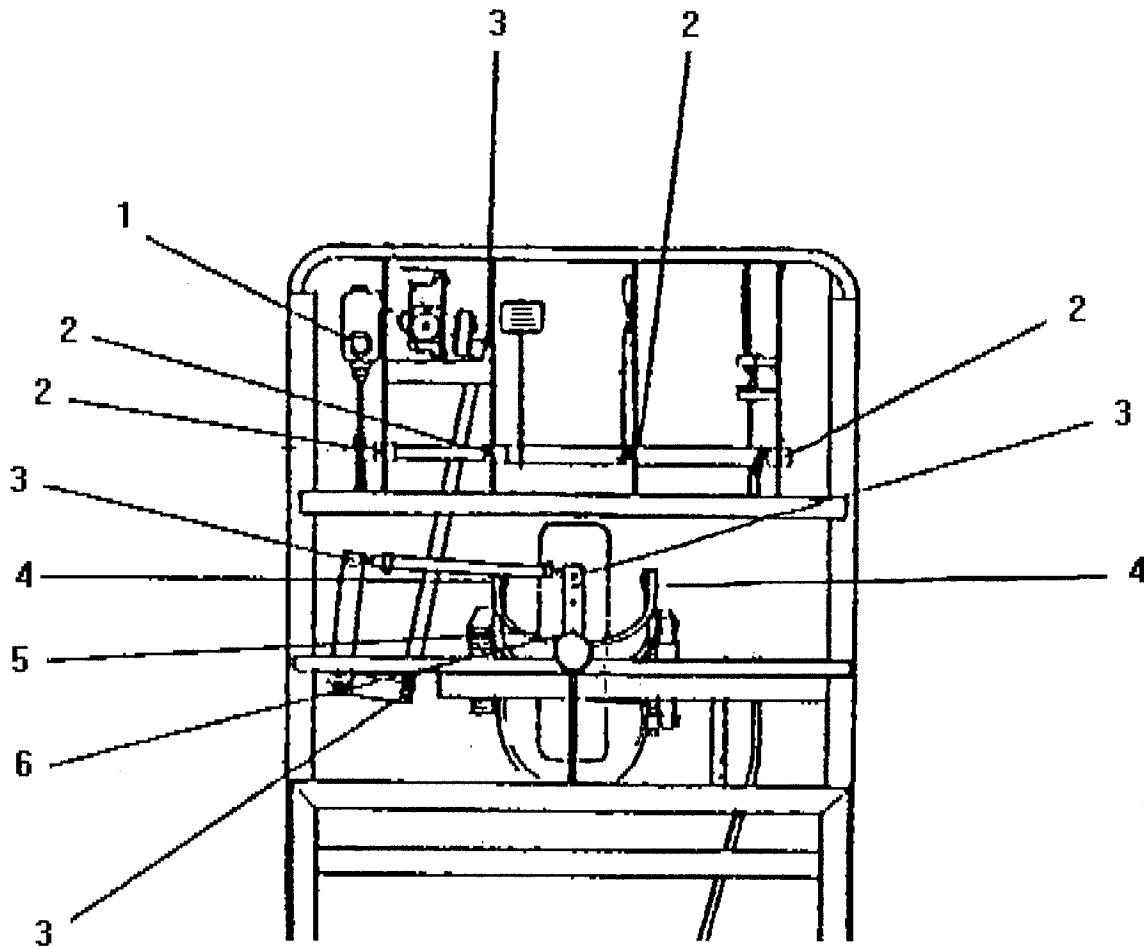

As Viewed From Top

#	Description	Locations	Lubricant type
1	Master Cylinder	1	DOT 3 Brake Fluid
2	Chassis Zerk Fittings	4	General purpose grease
3	Ball Joints	3	General purpose grease
4	Fork Pivot	2	General purpose grease
5	Front Wheel Hub Bearings	1	General purpose grease
6	Fork Bearings	1	General purpose grease

Electrical Troubleshooting

TOOLS NEEDED: Volt-OHM meter
 Test light (voltage equal to MAX battery voltage)
 9/16" comb. Wrench
 1/2" comb. Wrench
 62-027-31 test harness

- *All voltage tests done referenced to battery negative unless otherwise specified.*
- *Battery volts = full voltage available at batteries at time of test.*
- *All tests key switch on. Safety switches (if equipped) on.*
- *This test procedure must be performed in the order it was written. If you start in the middle or skip sections, you may not get the proper results.*
- *When "BATTERY volts" is specified it indicates the current full voltage available at the batteries*

⚠ WARNING DURING ALL TESTS

**BOTH DRIVE WHEELS JACKED UP OFF THE GROUND,
SUPPORTED BY JACK STANDS WITH FRONT WHEELS
BLOCKED.**

- **After any repairs are made completely test vehicle BEFORE lowering to ground.**

START:IF THE TRUCK RUNS IN ONLY ONE DIRECTION THEN GO TO SOLENOIDS

➤ **CONTROL WIRES AT PMC**

1. With the Accelerator pedal depressed to engage MS1 only (creep speed) and the directional switch in gear (forward or reverse).
 - a.) Test volts at PIN #2 on the PMC. If it is not 6-6.5 v. then GO TO ACCELERATOR MODULE.

Section 3

- b.) Test volts at PIN “KSI” on the PMC. If not BATTERY volts then GO TO KSI.
2. With the accelerator, pedal fully depressed.
 - a.) Test volts at PIN #2 on the PMC. If not 11-11.5 v. then GO TO ACCELERATOR MODULE.

➤ **POWER WIRING**

➤ **NOTE: All tests in this section are with the resistor at the ISO solenoid disconnected. Reconnect the resistor when done with this section.**

1. With the accelerator pedal depressed to engage MS1 only (creep speed).

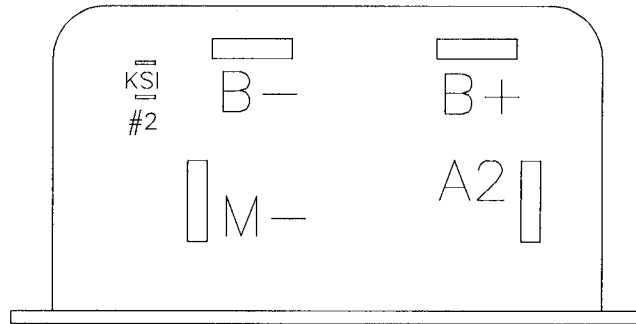

- a.) Test volts from BATTERY NEG to “B+” on the PMC. If not BATTERY volts then GO TO SOLENOIDS
- b.) Test volts from “B+” on the PMC to “B-” on the PMC. If not BATTERY volts then check the wire and connections from BATTERY NEG to “B-” on the PMC. >STOP
- c.) Using ohmmeter (R*10), check the ISO resistor. If not 250 ohms replace resistor.

➤ **NOTE: A defective resistor causes intermittent operation of control.**

2. Reconnect the resistor.
3. With the accelerator pedal depressed fully.
 - a.) Test volts from “M-” on the PMC to “B+” on the PMC. If not BATTERY volts then the PMC is bad. >STOP
 - b.) Connect the test light across MOTOR S1-S2 terminals. If the light is ON then the field is open. >STOP
 - c.) Connect the test light across MOTOR A1-A2 terminals. If the light is ON then the armature is open. >STOP

GO TO SOLENOIDS

➤ **ACCELERATOR MODULE (MAGNETIC OR SOLID STATE ONLY)**

➤ *Note: These tests are done at the accelerator using the 62-027-31 test harness.*

1. With the accelerator pedal depressed to engage MS1 only (creep speed).
 - a.) Test volts at PIN #4. If not BATTERY volts then GO TO KSI
 - b.) Test volts from PIN #4(+) to PIN #9(-). If not BATTERY volts then check the wire (pin #9 to circuit breaker), circuit breaker. >STOP
 - c.) Test volts at PIN #2. If not 6-6.5 v. then the accelerator module is bad. >STOP
 - d.) Test volts at PIN #5. If not BATTERY volts then the accelerator module is bad. >STOP

➤ *NOTE: A broken return spring will cause no output at PIN #5.*

2. With the accelerator, pedal fully depressed.

- e.) Test volts at PIN #2. If not 11-11.5 v. then the accelerator module may need adjusting or is bad. >STOP

➤ f.) If volts at MODULE (PIN #2) are good but at PMC (PIN #2) are bad then check the wire in pin #2 from the module to the PMC. >STOP

NOTE: Some models route wire #2 through a seat switch.

➤ **KSI**

1. Check the KEY-switch, safety interlock switches (if equipped) and charger interlock relay (if equipped) for continuity.

- a.) Some models route the key switch through the F&R switch
 - b.) Check control wiring. >STOP

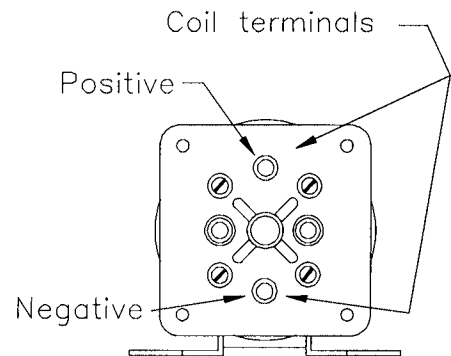

SOLENOIDS

Using ohmmeter (Rx10), check the ISO resistor. If not 250 ohms, replace the resistor.

➤ *NOTE: A defective resistor causes intermittent operation of control.*

If FORWARD only then GO TO FORWARD ONLY

Section 3

If REVERSE only then GO TO REVERSE ONLY

1. Place the directional switch in neutral.
2. If the ISO solenoid clicks when the accelerator pedal is depressed then GO TO ISO
3. Test volts from BATTERY positive to the ISO coil negative.
 - a.) If not BATTERY volts then check the negative control wiring and the circuit breaker. >STOP
4. With the accelerator, pedal fully depressed.
 - a.) Test volts across the ISO coil. If not BATTERY volts then check the wiring, MS1, safety switches, KEY-Switch. >STOP

Test volts across the ISO coil. If BATTERY volts then the ISO coil is bad. >STOP

➤ **ISO**

1. Connect the test light across the ISO power contacts and depress the accelerator pedal fully.
 - a.) If the light is on then the ISO solenoid is bad. >STOP
 - b.) If the light is off then check the power wiring to the batteries and to the PMC for opens. >STOP

➤ **FORWARD ONLY**

1. Place the directional switch in NEUTRAL.
2. Depress the accelerator pedal. Move the directional switch to reverse.
 - a.) If the REVERSE solenoid clicks then GO TO forward contacts.
 - b.) Check volts from BATTERY positive to the negative coil terminal on the REVERSE solenoid. If not BATTERY volts then check the solenoid bus bar connections. >STOP
 - c.) Check the voltage across the REVERSE solenoid coil.
 - i.) If BATTERY volts then the REVERSE solenoid is bad. >STOP
 - ii.) If not BATTERY volts then check the wiring, directional switch. >STOP

➤ FORWARD CONTACTS

CONNECT THE TEST LIGHT ACROSS THE NORMALLY CLOSED CONTACTS OF THE FORWARD SOLENOID

1. Depress the accelerator pedal fully.

If the light is on then the FORWARD solenoid is bad. >STOP

CONNECT the test light ACROSS the normally open contacts of the REVERSE SOLENOID

2. Depress the accelerator pedal fully.

If the light is on then the REVERSE solenoid is bad. >STOP

3. If the light did not come on, check all power wiring for opens. >STOP

➤ REVERSE ONLY

Place the directional switch in NEUTRAL.

1. Depress the accelerator pedal. Move the directional switch to FORWARD.

a.) If the FORWARD solenoid clicks then GO TO Reverse Contacts

b.) Check volts from BATTERY positive to the negative coil terminal on the FORWARD solenoid. If not BATTERY volts then check the solenoid bus bar connections. >STOP

c.) Check voltage across FORWARD solenoid coil.

i.) If BATTERY volts then the FORWARD solenoid is bad. >STOP

ii.) If not BATTERY volts then check the wiring, directional switch. >STOP

REVERSE CONTACTS

Connect the test light across the normally closed contacts of the REVERSE SOLENOID

1. Depress the accelerator pedal fully.

a.) If the light is on then the REVERSE solenoid is bad. >STOP

2. **CONNECT the TEST LIGHT ACROSS the normally open CONTACTS of the FORWARD SOLENOID**

a.) Depress the accelerator pedal fully.

3. If the light is on then the FORWARD solenoid is bad. >STOP

4. If light DID NOT come on then check all power wiring for opens. >STOP

If you reached this point without a solution then you may have an unanticipated problem or have made an error during testing.

Section 3

Normally open
contacts

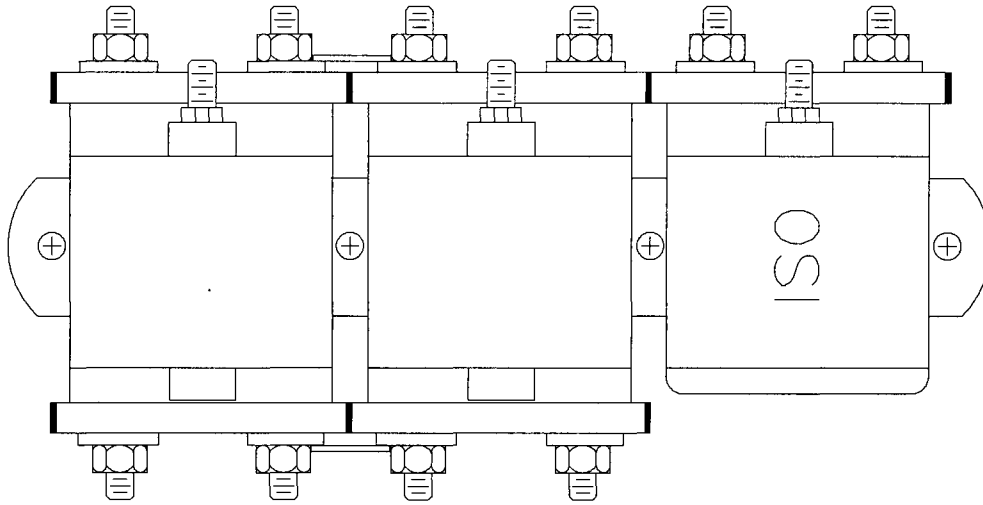

Normally closed
contacts

Wire Diagram B2-38 / B2-48 / B2-54

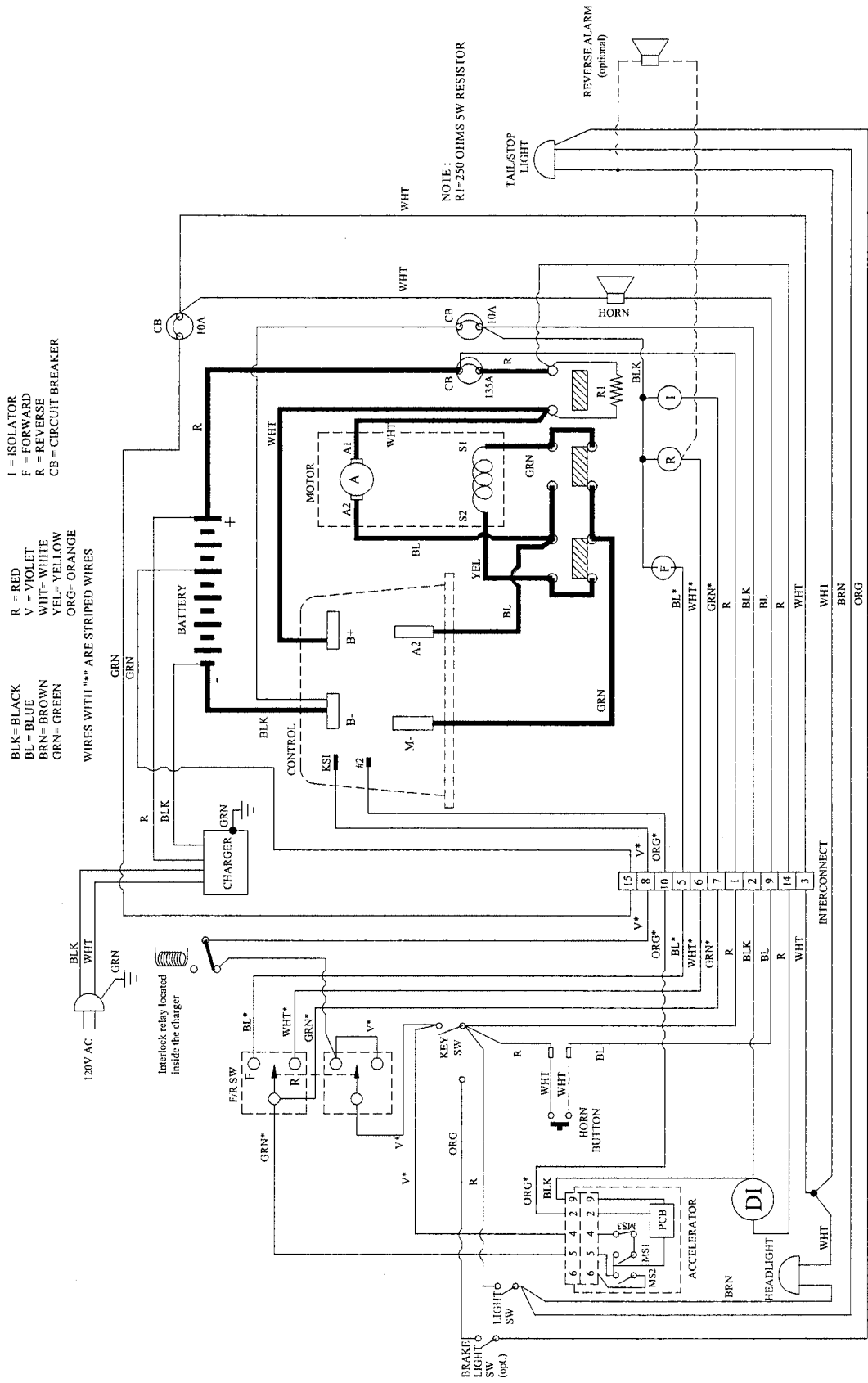

Section 3

LESTER CHARGER TROUBLESHOOTING

MODEL 7460 TYPE 36LC25-8ET

⚠ WARNING

HIGH VOLTAGE and HIGH DC CURRENT: If you do not understand any part of these tests, refer testing to a qualified electrical mechanic.

⚠ WARNING

Prevent the truck from moving. Before performing maintenance on any vehicle, disconnect the batteries, set the parking brake and block the wheels

1. Disconnect the charger from the AC and DC source.
2. If this is a built in charger then remove the charger from the truck.
3. Remove the charger cover.

⚠ WARNING

High voltage may be stored in the capacitor. Discharge the capacitor with an insulated screwdriver before proceeding. Do not touch the screwdriver blade while discharging the capacitor.

4. Inspect all internal wiring and repair as necessary.
5. Inspect the fuse link and replace if bad.
6. Test diodes.
 - a.) Use a VOM set at R x 100 ohms scale.
 - b.) Remove one lead from one diode.
 - c.) Connect test leads across one diode. Meter should either deflect to right side of scale or not at all.
 - d.) Reverse polarity on diode test leads. You should get the opposite reading of the previous test.
 - e.) If you get the same reading in both polarities then the diode is bad.
 - f.) Repeat the test on the other diode.

IT IS RECOMMENDED TO REPLACE THE DIODES AS A SET.

- g.) Reconnect the lead removed in step 6B to the diode.
7. Test the capacitor.

Use an analog VOM set at its highest ohms scale. Preferably R x 1000 (1K).

⚠ WARNING

High voltage may be stored in the capacitor. Discharge the capacitor with an insulated screwdriver. Do not touch screwdriver blade while discharging capacitor.

- b.) Disconnect one lead from the capacitor.
- c.) Connect the test leads across the capacitor.
The needle should deflect to low ohms reading and then slowly return to infinity (left side of scale). If the needle stays on low ohms reading or does not deflect at all then the capacitor is bad.

NOTE: CHECK THE CAPACITOR IN BOTH POLARITIES

- d.) Reconnect the lead removed in step 7B.
8. Reconnect the DC source only.
 9. Measure DC voltage from the diode block (+) (Fig 1) to the fuse assembly (-).
 - a.) If you do not get battery voltage then the wiring to the battery is bad.
 10. If the charger is equipped with an ammeter then check the continuity across the meter.
 - a.) If you do not get 0 ohms then the meter is bad.

⚠ WARNING

Electrical shock hazard! After next step, there will be un-insulated high voltage in the charger.

11. Reconnect the AC source.

⚠ WARNING

The charger must be grounded! The Green wire from the AC cord must be electrically attached to the charger cabinet.

Repairs to house wiring must be done by a qualified electrician.

- a.) Measure AC input voltage at 1/4" spade connectors on timer (Fig. 2, Terminals 1 and 2).
- b.) If not at approximate charger AC voltage listed on the charger spec plate, then AC input is bad.

Possible problems:

- a.) Wiring to AC cord.
- b.) AC cord or plug.
- c.) House wiring or circuit breaker. To test, plug a known good light into the wall outlet.

12. Measure AC output voltage at timer, terminals 2 and 3.
 - a.) If it is not the same as the input voltage then the timer is bad.
13. Measure the AC voltage at diodes
 - a.) If it is not 79-90 volts AC then the transformer is bad

Section 3

Testing the Interlock Relay

Operation

The Interlock Relay disables the vehicle from running whenever the charger is connected to a working AC power source. When the charger is plugged in, the relay contacts open and break the Key Switch connection to the speed controller. The Interlock Relay is available for built-in chargers only. Not all built-in chargers are equipped with this relay. To identify chargers is equipped with the Interlock Relay:

Inspect the charger wire harness where it enters the charger cabinet for two Violet/Black wires. If these wire are present then the charger is equipped with the Interlock Relay.

Testing

- 1. Make sure the key-switch is in the "OFF" position, then remove the key.*
- 2. Place the forward-reverse switch in the center "OFF" position.*
- 3. Set the park brake.*
- 4. Place blocks under the front wheels to prevent vehicle movement.*
- 5. Disconnect the main positive and negative cables at the batteries.*

⚠ WARNING

6. Disconnect the charger from the AC power source.
7. Disconnect the two Violet/Black wires at the charger harness knife connectors.
8. Set the DMM to check for continuity and connect the DVM leads to the wires going into the charger.
 - a) The DMM should indicate a closed circuit. If it indicates an open circuit, then the relay or the wire to the relay have failed.

Stop here and repair the problem.

9. Connect the charger to a working AC power source.
 - a) The charger should turn on. If the charger does not turn on then there may be a problem with the AC power source or the AC wiring to the charger. Refer to the beginning of this section for charger troubleshooting. DO NOT continue until you have confirmed that the AC power source is working.
 - b) The DMM should indicate an open circuit. If it still indicates a closed circuit, then the relay or the wire to the relay has failed.

Stop here and repair the problem

- c) If the DMM indicates an open circuit then the interlock relay is functioning normally.

***B2-38 Three Wheel
Front Axle/Steering
Supplement***

Three Wheel Supplement Removal

1. Disconnect the batteries.
2. Lift the front end and support with jack stands.
3. Block the rear wheels to prevent the truck from rolling.

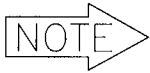

THE FRONT WHEEL AND SPACERS WILL FALL OFF THE AXLE WHEN IT IS REMOVED.

4. Remove the front axle
5. Remove the ball joint from the fork assembly.



SUPPORT THE FORK. AFTER THE NEXT STEP, THE FORK WILL NOT BE RETAINED IN THE FORK COLLAR.

6. Remove the bearing cap and fork nut.
7. Remove the fork out from the bottom of the truck.

Installation

1. Install in reverse order.
2. Tighten the fork nut so that there is no play in the fork bearings.
3. Tighten the front axle nuts so that when the wheel is spun it comes to a stop in one revolution.
4. Tighten the ball joint to 40-45 ft. lbs.

Centering the Steering

1. Loosen the ball joint clamps on the upper tie rod.
2. Adjust the upper tie rod so that the upper arm on the idler arm weldment is parallel to the ball joint mounting tab on the fork.
3. Tighten the ball joint clamps

4. Remove the drag link ball joint from the pitman arm.
5. Center the pitman arm on the steering gear (see “Centering the Steering,” in section 3, of 4 wheel manual).
6. Position the front fork straight ahead and tie it off so it can not move.
7. Center the steering wheel and tie off so it can not move.
8. Adjust the drag link so that it can be installed back into the pitman arm without binding.
9. Tighten the ball joint to 40-45 ft. lbs.
10. Tighten the ball joint clamps securely.

Repair

Wheel bearings

See section 3.

Steering gear adjustment

See section 3.

Fork yoke bearings

1. Remove the front fork.
2. Clean ALL grease from the inside of the hub and bearings.
3. Inspect and replace the races and bearings as a set as necessary.

⚠ CAUTION *It is recommended to replace both upper and lower bearings at the same time.*

See installation (above) to reassemble.

Three Wheel Supplement

FRONT FORK

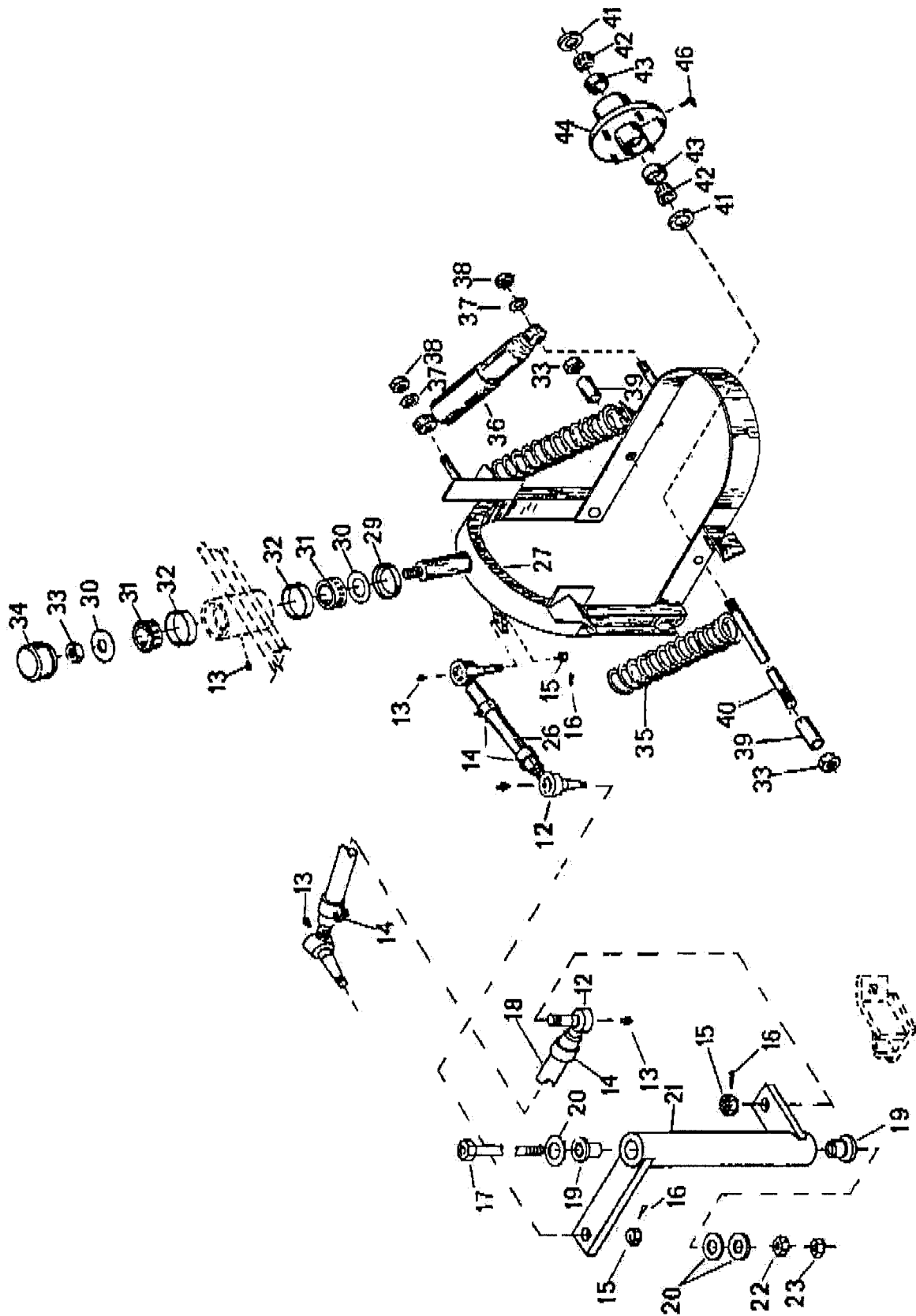

Front Fork			
ITEM #	PART #	DESCRIPTION	QTY
12	86-501-98	Ball joint (left)	2
12	86-501-98	Ball joint (right)	2
13	87-074-00	Grease fitting	2
14	86-510-00	Ball joint clamp assembly	4
15	88-159-85	Ball joint nut	4
16	88-527-11	Cotter pin	4
17	50-034-00	Idler arm rod	1
18	18-057-11	Drag link	1
19	32-215-00	Bushing	2
20	88-148-61	1/2" SAE flat washer	3
21	18-084-50	Idler arm weldment	1
22	88-149-80	1/2 NC hex nut	1
23	88-149-81	1/2 NC hex lock nut	1
26	18-035-00	Tie rod	1
27	14-024-10	Front fork	1
29*	45-307-00	Dust seal	2



THE NUMBERING IN THIS TABLE BEGINS AT 12. AT THE TIME OF PRINTING THE INFORMATION WAS NOT AVAILABLE FOR ITEMS 1 THROUGH 11. YOU CAN FIND THE REMAINDER OF THIS TABLE ON THE NEXT PAGE.

* Depending on the year range of your vehicle this parts may not be installed in the front fork.

Three Wheel Supplement

FRONT FORK (CONT'D)

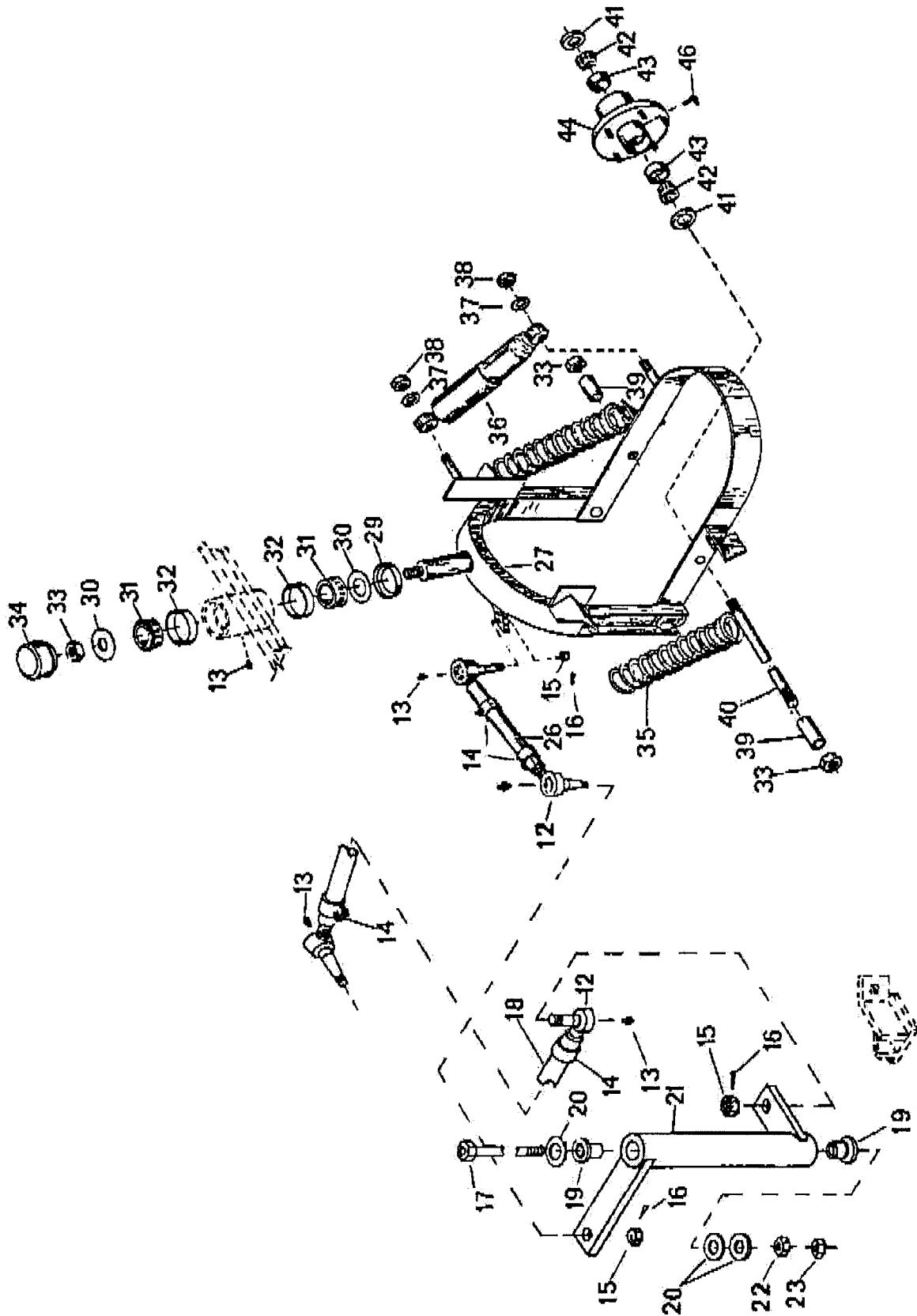

Front Fork			
ITEM #	PART #	DESCRIPTION	QTY
30	88-228-60	3/4 Cut washer	1
31	80-011-00	Bearing	2
32	80-102-00	Bearing race	2
33	88-229-81	3/4 NC lock nut	1
34	92-105-00	Bearing cap	1
35	85-150-00	Fork spring	2
36	86-000-00	Front shock	1
37	88-188-61	5/8 SAE flat washer	2
38	88-189-81	5/8 NC lock nut	2
39	16-043-00	Wheel spacer	2
40	15-030-00	Front axle	1
41	45-308-00	Axle seal	2
42	80-015-00	Front wheel bearing	2
43	80-105-00	Bearing race	2
44	12-120-00	Hub (with bearings, races, seals)	1
46	87-050-00	Grease fitting	1

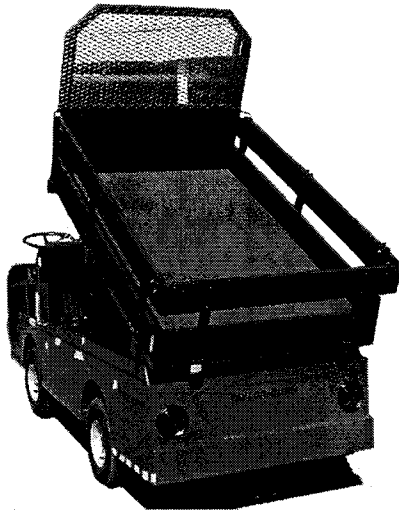

B2-48 With Stake Side Dump Bed Option

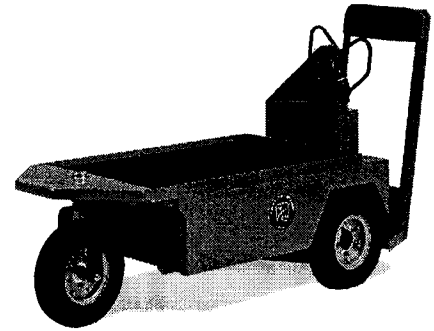

SC1-59 Stock Chaser

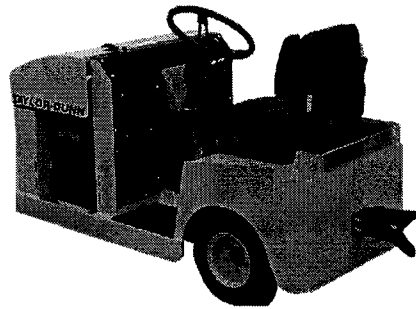

E4-55 Sit Down Tow Tractor



C4-25 Sit Down Tow Tractor

SECTION 4

Illustrated Parts list

Contents

Front Axle B2-48 -----	2
Front Axle B2-54 -----	4
Front Suspension for B 2-48/B2-54 -----	6
Steering Gear -----	8
Steering Column Assembly -----	10
Drag Link -----	10
Park Brake Linkage -----	12
Parking Brake -----	14
Foot Brake Linkage B2-48/B2-38 -----	16
Foot Brake Linkage B2-54 -----	18
Rear Brakes -----	20
Front Brakes -----	22
Accelerator/Brake Pedal -----	24
B2-48 Brake Lines and Hoses -----	26
B 2-54 Brake Lines and hoses -----	28
B 2-48 Rear Suspension -----	30
B2-54 Rear Suspension -----	32
Instrument Panel -----	34
Frame -----	36
Motors -----	38
B2-48 and B2-38 Standard Motor -----	40
Rear Axle B2-48 -----	42
Rear Axle B2-54 -----	44
3rd Member and Axle Assembly -----	46
Power Traction Assembly -----	48
Control Panel B2-38 and B2-48 -----	50
Control Panel B2-54 -----	52
Charger -----	54
Miscellaneous Electrical System Parts -----	56
Decals -----	58

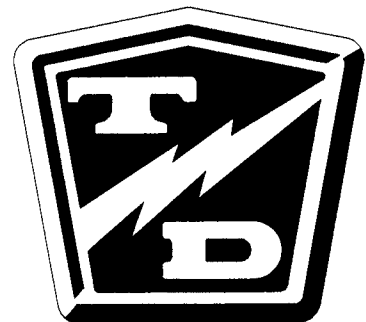

Front Axle B2-48

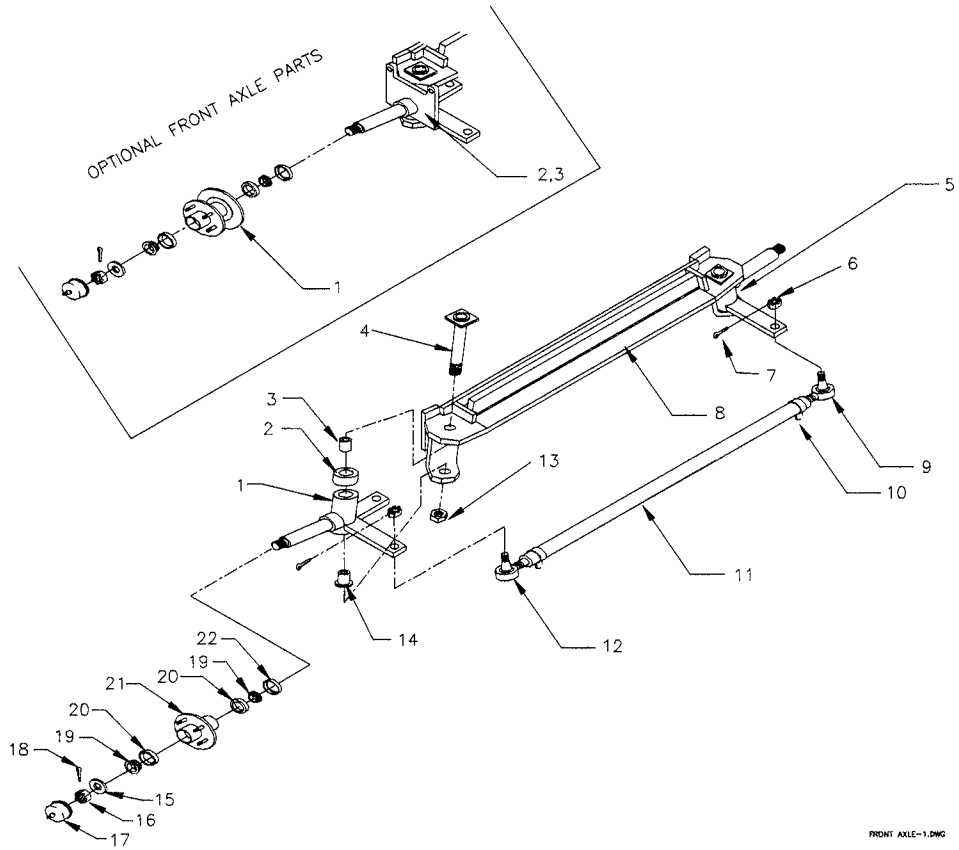

FRONT AXLE (15-049-10) B2-48			
ITEM #	PART #	DESCRIPTION	QTY
1	14-099-98	Steering Yoke, Left	1
2	80-309-00	Thrust Bearing	2
3	32-204-00	Bushing 7/8 ID X 1 OD, Bronze, Grooved	2
4	21-013-00	King Pin	2
5	14-099-99	Steering Yoke, Right	1
6	88-159-85	1/2-20 NF Slotted HEX Nut	2
7	88-527-11	Cotter Pin, 1/8 X 1, Steel	2
8	15-049-10	Standard B2-48 & B2-54 Front Axle (Complete)	1
9	86-501-99	Ball Joint, F1 & P2, Right W/Zerk Fitting	1
10	86-510-00	Assembly, Ball Joint Clamp	2
11	18-041-00	Sleeve, Steering, Adjust, 22.5	1
12	86-501-98	Ball Joint, F1 & P2, Left W/Zerk Fitting	1
13	88-279-81	7/8 NF HEX Head Lock Nut (For Standard Front Axle Only)	2
14	32-200-00	Bushing 7/8 ID X 1 OD, Bronze, Flanged W/Groove	2
15	88-228-61	3/4 SAE Washer	2
16	88-239-85	3/4 NF HEX Slotted Nut	2
17	92-104-00	Dust Cap W/Grease Fitting	2
18	88-527-14	Cotter Pin, 1/8 X 1-1/2, Steel	2
19	80-017-00	1" ID Tapered Bearing	2
20	80-103-00	Inner & Outer Bearing Races, (2-inner & 2-outer)	4
21	12-124-00	Hub, Wheel, 5 Stud	2
22	45-338-00	Grease Seal	2
OPTIONAL FRONT AXLE PARTS			
1	12-158-10	Hub, with Disc, 5 Stud	2
2	14-248-97	Steering Yoke, Left	1
3	14-248-98	Steering Yoke, Right	1
4	92-104-01	Dust Cap Without Grease Fitting	2
NOT SHOWN	88-289-81	7/8 NF Hex Head Lock Nut(For use on optional front axle only. Replaces #13 above.)	2
	15-049-50	Optional Front Axle with Hydraulic Disc Brakes for B2-48 & B2-54 (Complete)	1

Front Axle B2-54

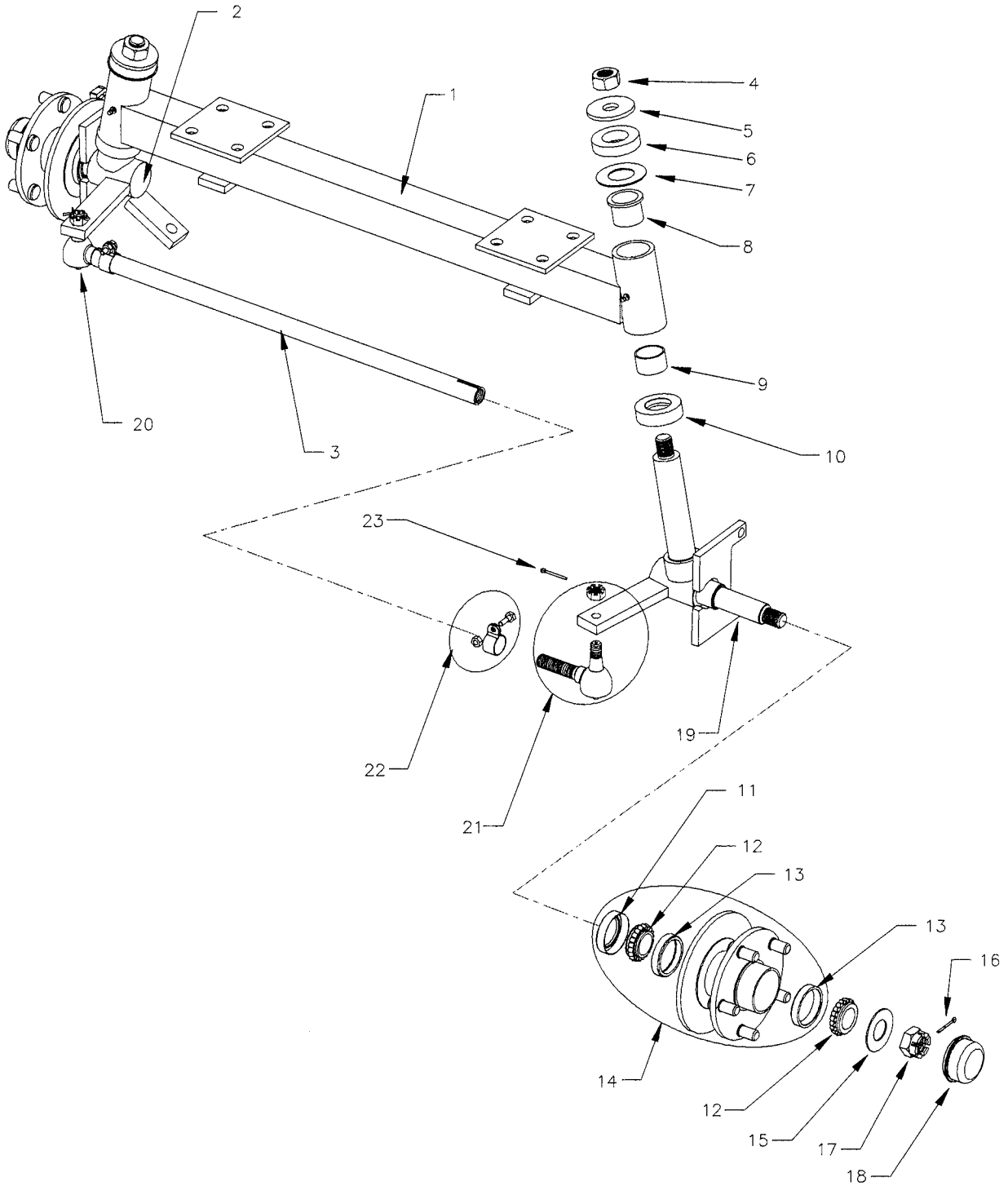

FRONT AXLE ASSEMBLY 15-049-76 (INCLUDES BRAKES)			
ITEM #	PART #	DESCRIPTION	QTY
1	15-049-71	Axle Beam (incl 8, 9)	1
2	21-020-21	Left Steering Knuckle	1
3	18-041-05	Steering sleeve	
4	88-239-86	3/4-NF Hex Slotted Nut	2
5	88-228-60	3/4 Cut Flat Washer	2
6	98-603-07	Rubber Bushing	2
7	01-220-99	Washer	2
8	32-240-44	Bushing	2
9	32-240-43	Bushing	2
10	80-309-12	Thrust Bearing	2
11	45-338-00	Grease Seal	2
12	80-017-00	Tapered Bearing	4
13	80-103-00	Tapered Bearing Race	4
14	12-158-10	Wheel Hub W/Rotor (incl 1-#12, 1-#11, 1-#13)	2
15	88-228-61	3/4 SAE Flat Washer	2
16	88-527-14	1/8 x 1-1/2 Cotter Pin	2
17	88-239-85	3/4-NF Hex Slotted Nut	2
18	92-104-01	Bearing cap	2
19	21-020-20	Right Steering knuckle	1
20	86-501-98	Ball Joint (left thread)	1
21	86-501-99	Ball Joint (right thread)	1
22	86-510-00	Ball Joint Clamp	2
23	88-527-11	1/8 x 1 Cotter Pin	2

Front Suspension for B 2-48/B2-54

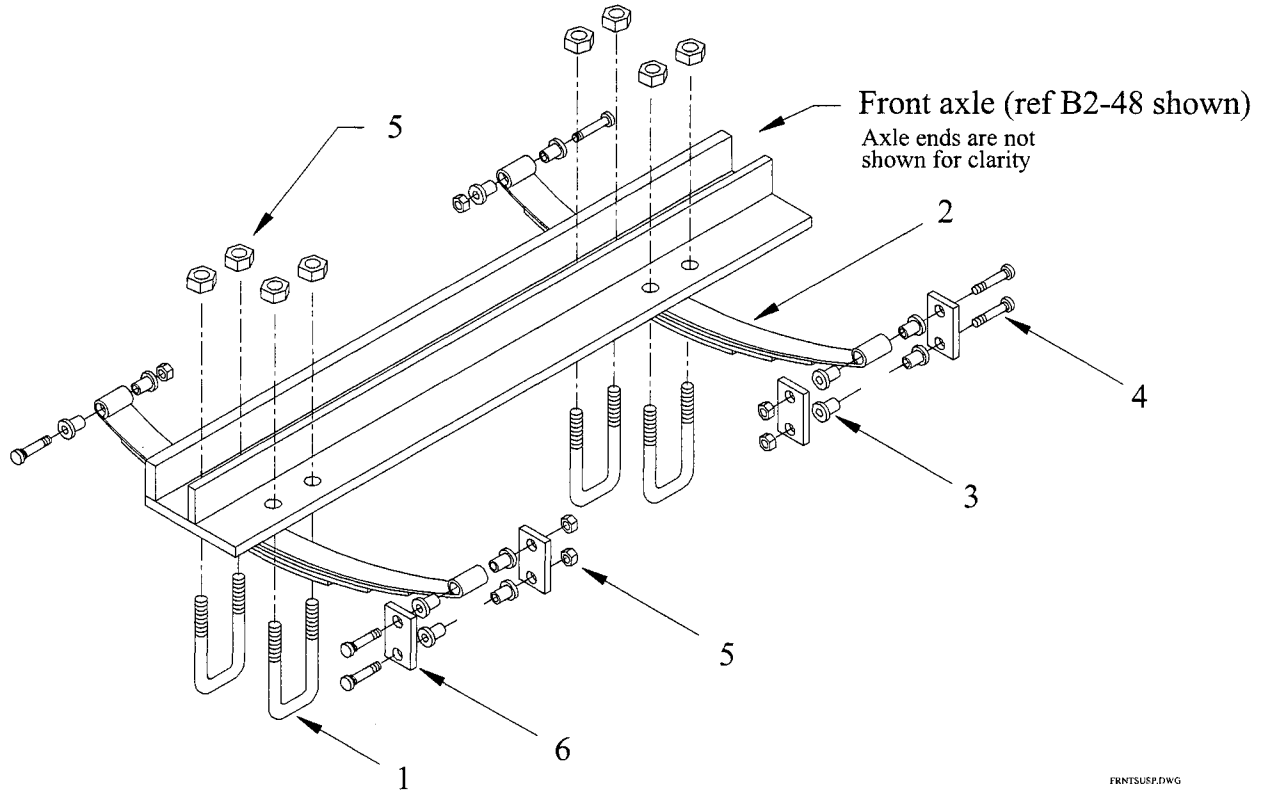

FRONT SUSPENSION			
ITEM #	PART #	DESCRIPTION	QTY
1	96-103-00	U-Bolt (For B2-54) Length 3"	4
	96-120-00	U-Bolt (For B2-48) Length 2"	4
2	85-498-00	Leaf Spring (For B2-48)	2
	85-486-00	Leaf Spring (For B2-54)	2
3	32-214-50	Spring Bushing	12
4	96-240-00	Shackle Bolt	6
5	88-149-81	1/2 NC Lock Nut	14
6	16-872-00	Spring Shackle	4

Steering Gear

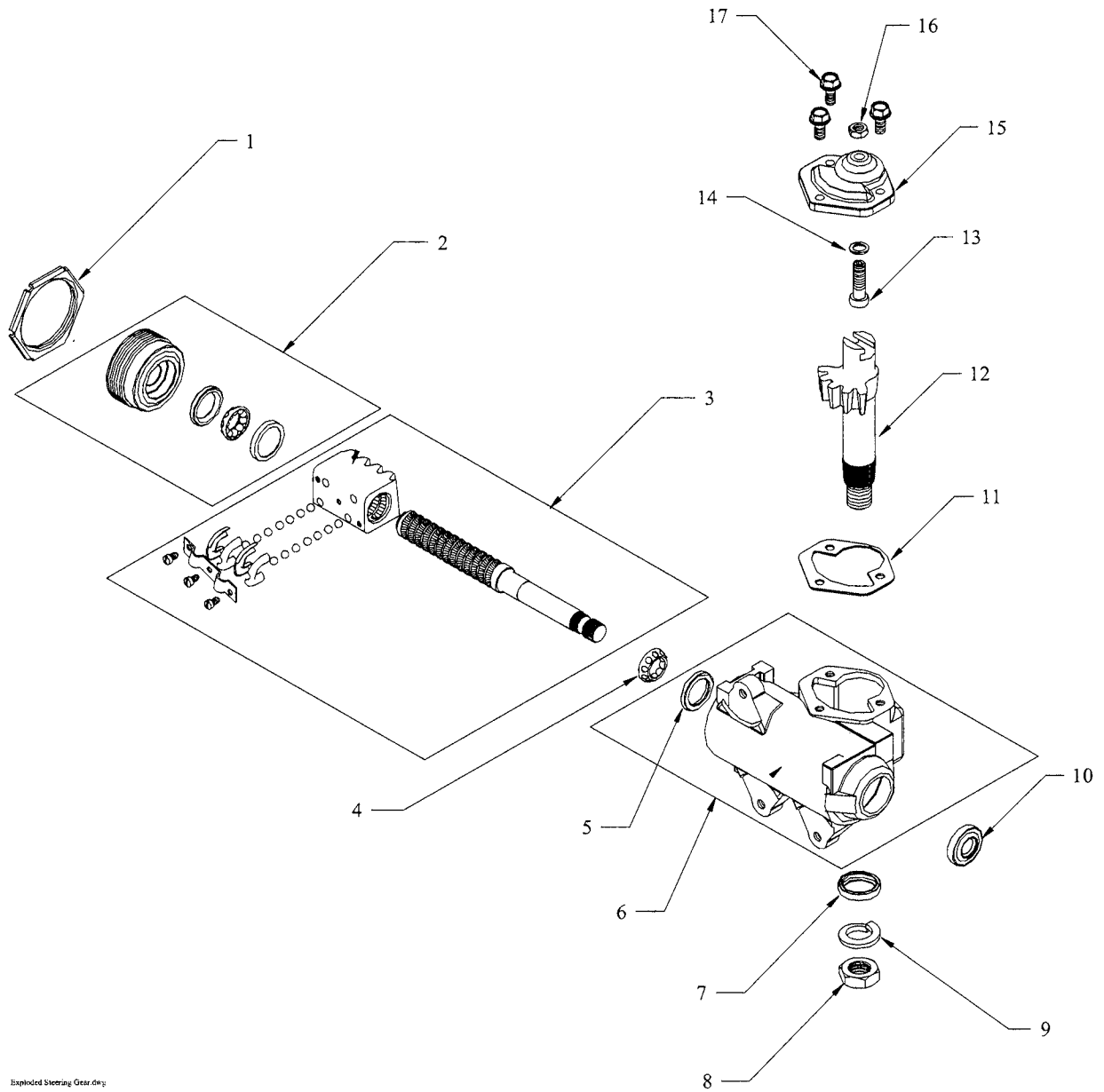

STEERING GEAR			
ITEM#	PART #	DESCRIPTION	QTY
1	18-308-70	Locknut, Worm Bearing Adjuster	1
2	18-308-71	Adjuster Assembly	1
3	18-308-72	Worm Assembly	1
4	18-308-23	Upper Worm Bearing	1
5	18-308-22	Upper Worm Bearing Race	1
6	18-308-77	Housing, Steering Gear	1
7	18-308-78	Seal, Pitman Shaft	1
8	18-308-80	Nut, Pitman Shaft	1
9	18-308-81	Lock Wahser, Pitman Shaft	1
10	18-308-79	Seal, Worm Shaft	1
11	18-308-82	Gasket, Side Cover	1
12	18-308-76	Pitman Shaft	1
13	18-308-75	Lash Adjuster	1
14	18-308-85	Shim Kit	1
15	18-308-84	Side Cover	1
16	18-308-86	Nut, Lask Adjuster	1
17	18-308-83	Bolt, Side Cover	3

Steering Column Assembly

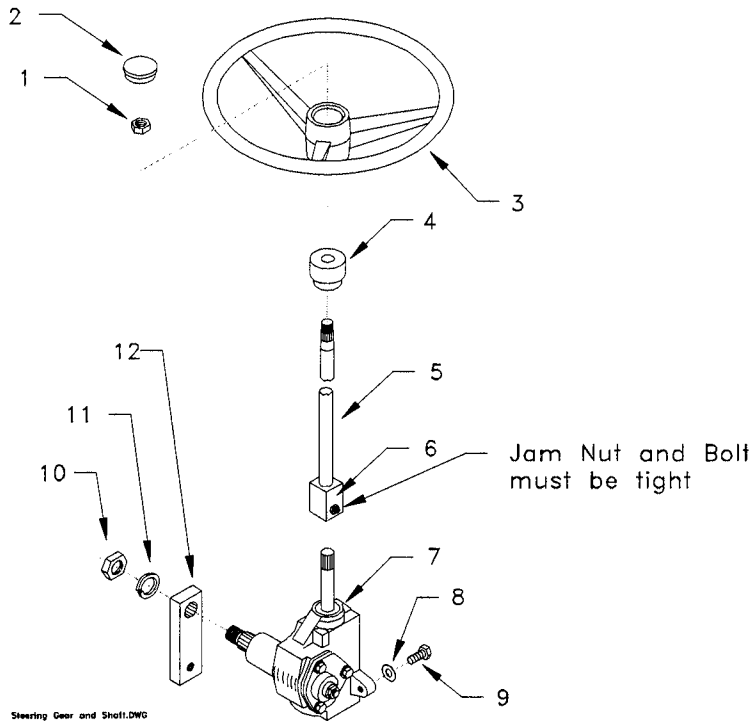

Drag Link

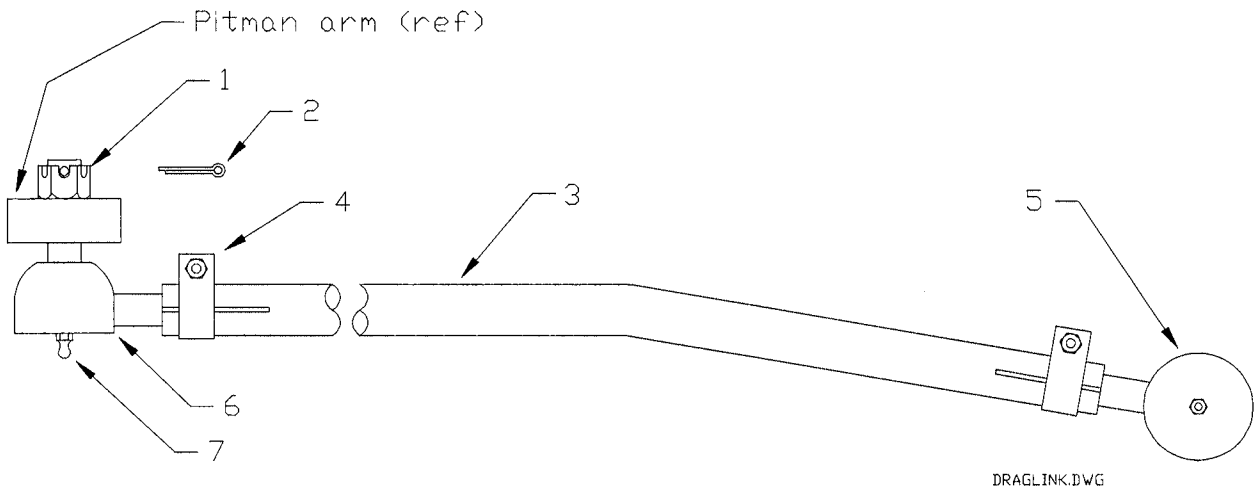

STEERING COLUMN ASSEMBLY			
ITEM #	PART #	DESCRIPTION	QTY
1	88-159-82	1/2" NF Jam Nut	1
2	19-011-25	Steering Wheel Cap	1
3	19-011-20	Steering Wheel	1
4	32-248-10	Upper Steering Shaft Bushing	1
5	20-031-65	Steering Shaft with Clamp	1
6	18-308-45	Assembly, Steering, Clamp (Includes #'s 5&7)	1
7	18-308-21	Steering Gear	1
8	88-128-62	7/16" Split Lock Washer	3
9	88-120-15	7/16" X 1" NC Hex Bolt	1
10	88-279-82	7/8" NF Jam Nut	1
11	88-268-62	7/8" Split Lock Washer	1
12	18-104-00	Pitman Arm	1
DRAG LINK (B2-48 & B2-54)			
1	88-159-85	Castle Nut	2
2	88-257-11	Cotter Pin	2
3	18-057-11	Drag Link	1
4	86-510-00	Ball Joint Clamp	2
5	86-501-99	Ball Joint with Grease Fitting (RH)	1
6	86-501-98	Ball Joint with Grease Fitting (LH)	1
7	87-071-00	Grease Fitting	2

Park Brake Linkage

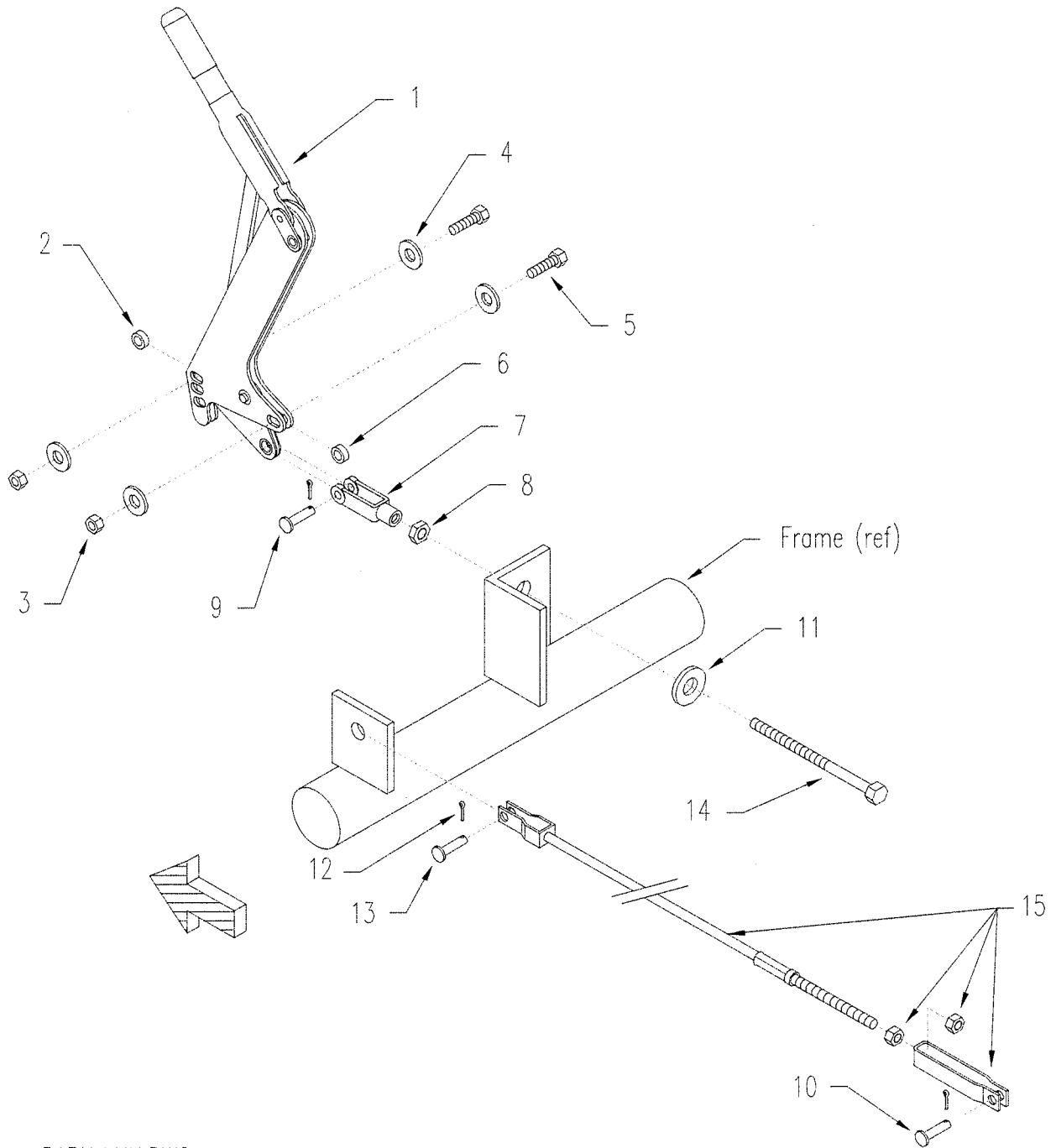

PARK_LNK.DWG

PARKING BRAKE LINKAGE			
ITEM #	PART #	DESCRIPTION	QTY
1	51-340-00	Park Brake Lever	1
2	-	Spacer (Part of #1)	
3	88-089-81	5/16" NC Hex Lock Nut	2
4	88-088-61	5/16" SAE Flat Washer	4
5	88-080-16	5/16" X 2" NC Hex Bolt	2
6	-	Spacer (Part of #1)	
7	96-762-00	3/8" Clevis	1
8	88-119-80	3/8" NF Hex Nut	2
9	96-773-10	5/16" X 1-1/8" Clevis Pin	1
10	96-773-00	5/16" X 1" Clevis Pin	1
11	88-108-60	3/8" Cut Flat Washer (QTY Spaced as Required)	
12	88-527-11	1/8" X 1" Cotter Pin	3
13	96-773-00	5/16" X 1" Clevis Pin	1
14	88-111-28	3/8" NF Hex Bolt	1
15	96-821-00	Park Brake Cable Assembly, Adj. 63.5m X 60m	1

Parking Brake

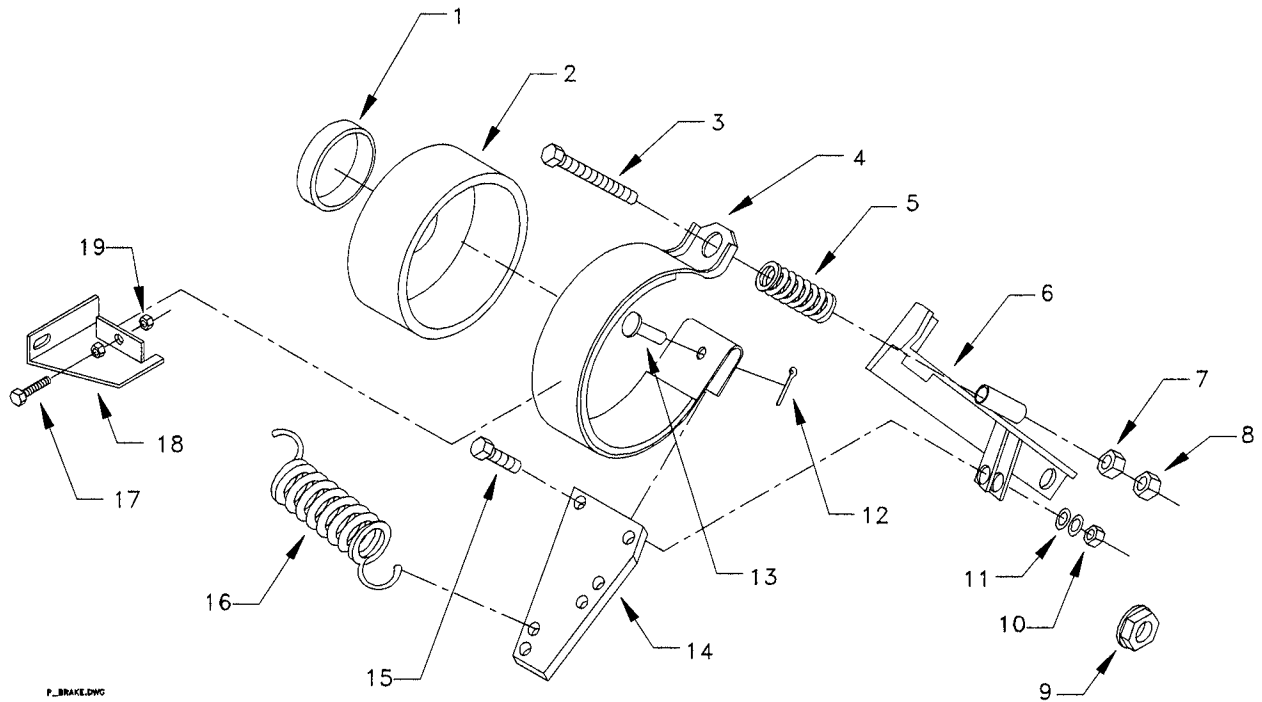

PARKING BRAKE			
ITEM #	PART #	DESCRIPTION	QTY
1	45-331-00	Pinion Seal	1
2	41-352-00	Brake Drum	1
3	96-245-10	Brake Adjusting Bolt	1
4	41-661-60	Brake Band Kit (Incl. #s 3, 5, 7, 8, 9, 12, 13)	1
5	85-060-20	2-1/2" Long Spring	1
6	41-372-10	Mounting Bracket	1
7	88-159-84	1/2"-20 NF Lock Nut	1
8	88-159-82	1/2" NF Hex Jam Nut	1
9	97-250-00	Pinion Nut	1
10	88-109-81	3/8" Lock Nut	1
11	88-108-61	3/8" Lock Washer	2
12	88-517-11	3/32" X 1" Cotter Pin	1
13	96-771-00	Clevis Pin	1
14	50-656-04	Brake Arm	1
15	88-101-13	3/8" X 1-1/4" NC Grade 5 Hex Bolt	1
16	85-270-00	Return Spring 4-3/8" Long	1
17	88-080-13	5/16" X 1-1/4" Hex Bolt	2
18	41-371-10	Alignment Bracket	2
19	88-089-91	5/16" Hex Jam Nut	4

Foot Brake Linkage B2-48/B2-38

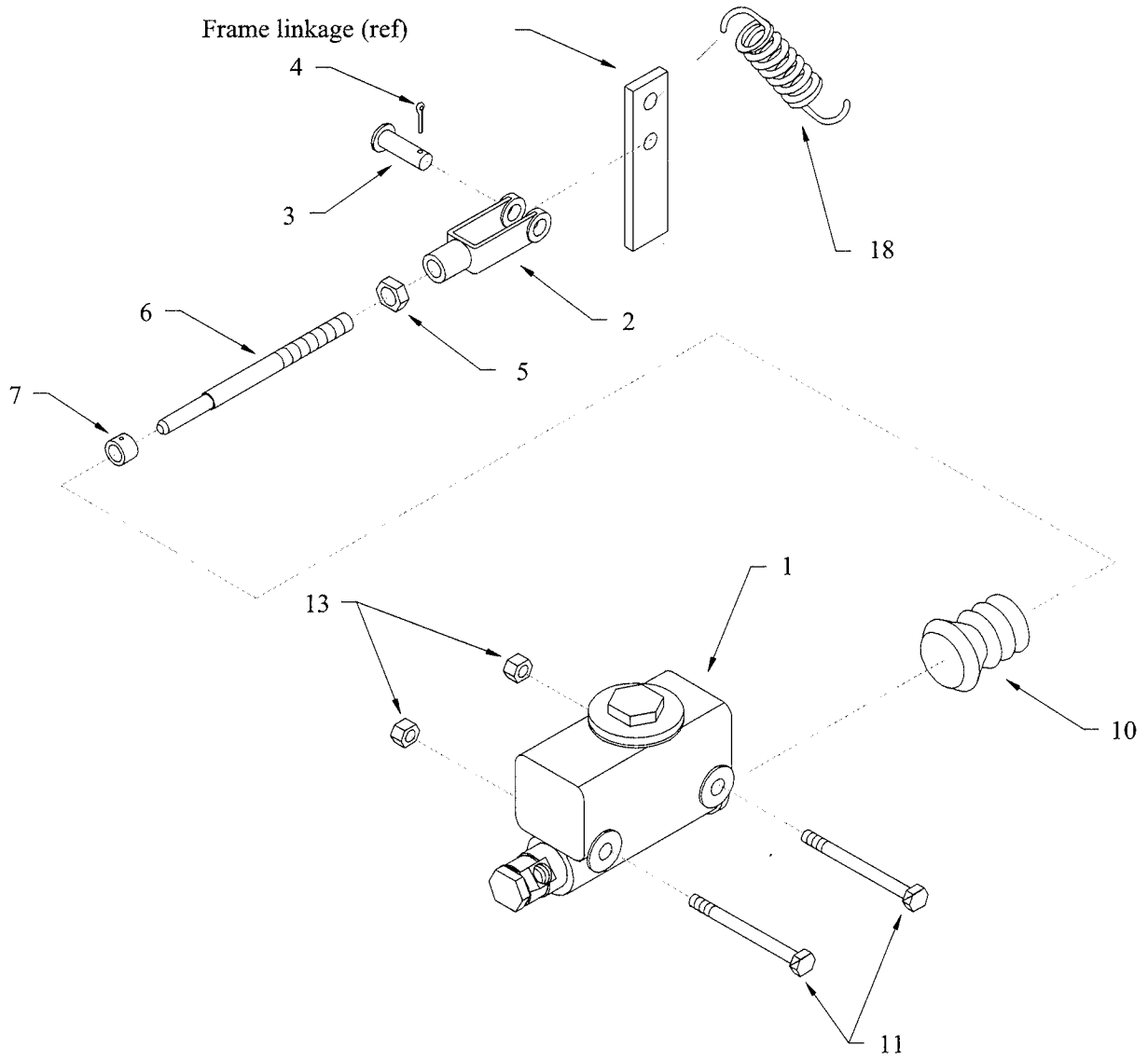

FOOT BRAKE LINKAGE B2-48/B2-38			
ITEM#	PART #	DESCRIPTION	QTY
1	99-510-02	Master Cylinder (Incl. #'s 8, 9, 12) (FOR B2-48/38)	1
2	96-762-00	3/8 Clevis	1
3	96-772-00	Clevis Pin	1
4	88-527-11	Cotter Pin	1
5	88-119-80	3/8" NF Nut	1
6	50-009-00	Push Rod	1
7	17-104-00	Collar	1
8			
9			
10	99-510-51	Rubber Boot	1
11	88-101-20	3/8" X 3" NC Hex Bolt	2
12			
13	88-109-81	Hex Lock Bolt	2
14			
15			
16			
17			
18	85-250-00	3-5/8" Long, Spring	1
Not Shown	99-567-00	90-degree Adapter on Master Cylinder Fitting (4-Wheel brakes only)	0 or 1

Foot Brake Linkage B2-54

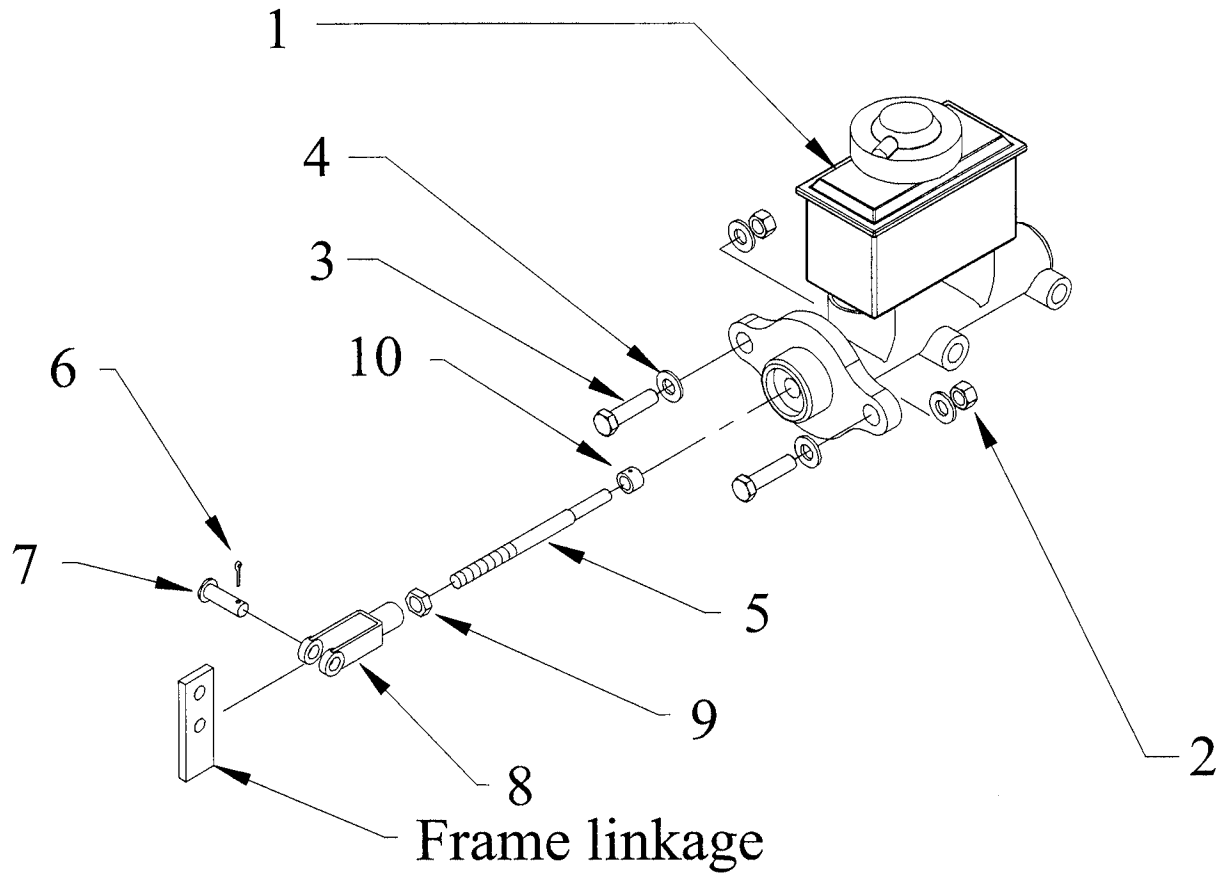

Foot Brake Linkage B2-54			
ITEM #	PART #	DESCRIPTION	QTY
1	99-511-20	Master Cylinder	1
2	88-089-81	5/16-NC Hex Lock Nut	2
3	88-081-11	5/16 x 1 Hex Hex Bolt, Grade-5	2
4	88-088-61	5/16 SAE Flat Washer	4
5	50-009-05	Push Rod	1
6	88-517-09	3/32 x 3/4 Cotter Pin	1
7	96-772-00	3/8 x 1-1/8 Clevis Pin	1
8	96-762-00	3/8 Clevis	1
9	88-119-80	3/8-NF Hex Nut	1
10	17-104-00	Collar	1
Not Shown	99-510-51	Rubber Boot	1
	99-511-53	Master Cylinder Cap	1
	99-511-52	Master Cylinder Cap Seal	1

Rear Brakes

WARNING

The axle mounting bolts and the brake body bolt nuts can only be used once. If removed they must be replaced.

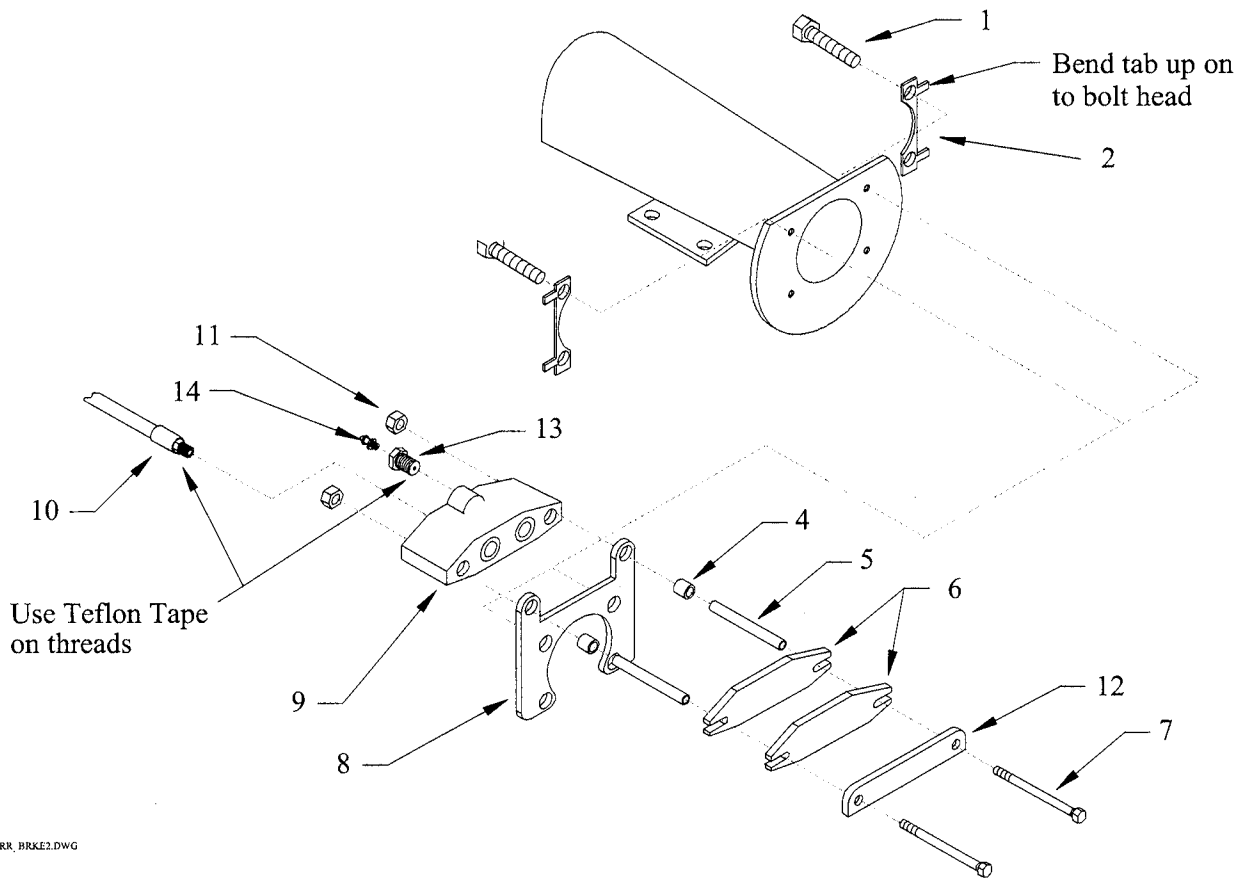

REAR BRAKES			
ITEM#	PART #	DESCRIPTION	QTY
1	96-327-00	Axle Mounting Bolt	8
2	41-350-05	Locking Tab	4
4	32-240-40	Bushing	4
5	41-382-52	Spacer	4
6	41-348-70	Brake Pad	4
7	88-067-21	Brake Body Bolt	4
8	41-350-08	Axle Retaining Bracket	2
9	41-350-68	Brake Body (Left and Right)	2
10	99-580-20	Brake Hose	2
11	88-069-82	Brake Body Nut (Grade 8) Do Not Reuse	4
12	41-350-51	Brake Pad Backing Plate	2
13	99-588-01	Bleeder Fitting	2
14	99-588-00	Bleeder Valve	2
Not Shown	41-350-66	Brake Body Rebuild Kit	2

Front Brakes

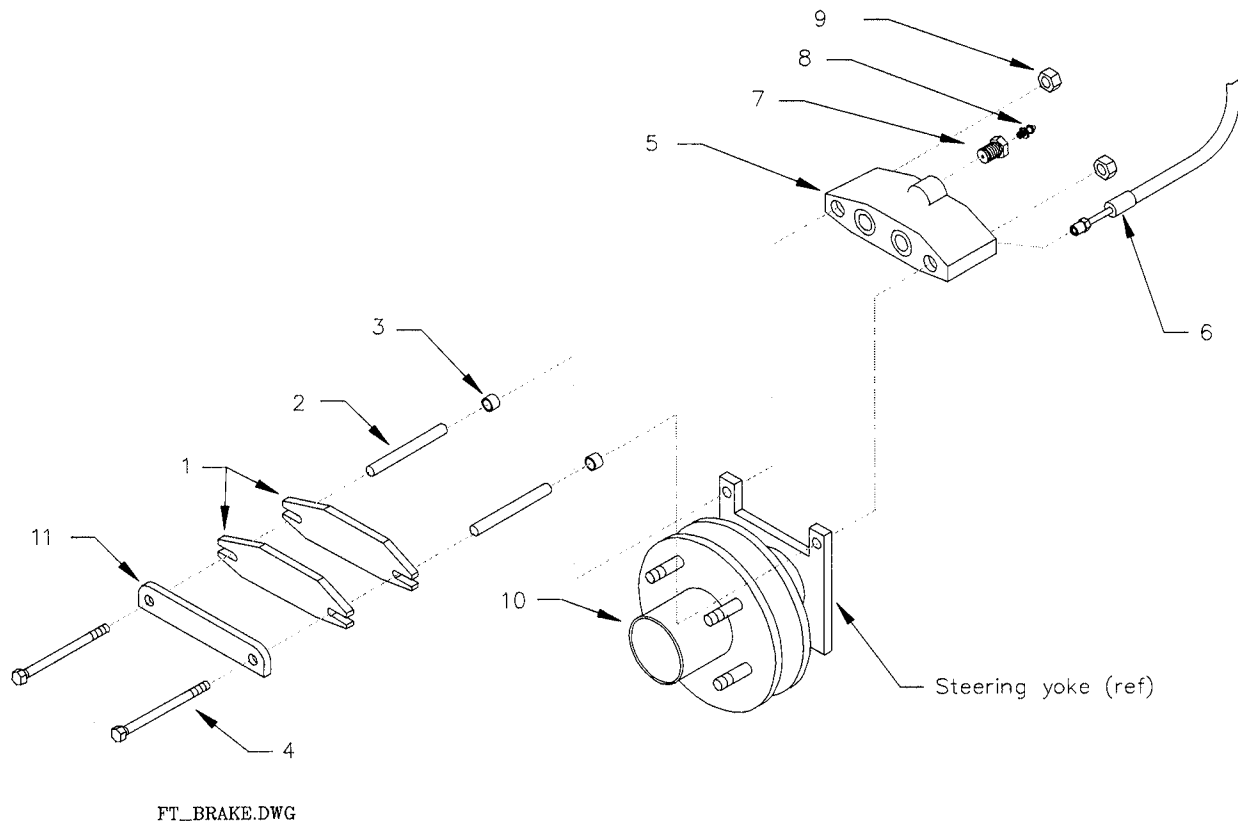

FRONT BRAKES FOR B2-54 (OPTIONAL FOR B 2-48)			
ITEM#	PART #	DESCRIPTION	QTY
1	41-348-70	Brake Pad	4
2	41-348-52	Spacer	4
3	32-240-40	Bushing	4
4	88-067-21	Brake Body Bolt (Grade 8)	4
5	41-350-71	B 2-48 Brake Body	2
	41-350-30	B 2-54 Brake Body	2
	41-350-66	Rebuild Kit	N/A
6	99-580-10	Brake Hose	2
7	99-588-01	Brake Bleeder Fitting	2
8	99-588-00	Brake Bleeder Valve	2
9	88-069-82	Brake Body Nut (Grade 8) DO NOT REUSE	4
10	See Front Axle	Front Hub	2
11	41-350-51	Brake Pad Backing Plate	2

Accelerator/Brake Pedal

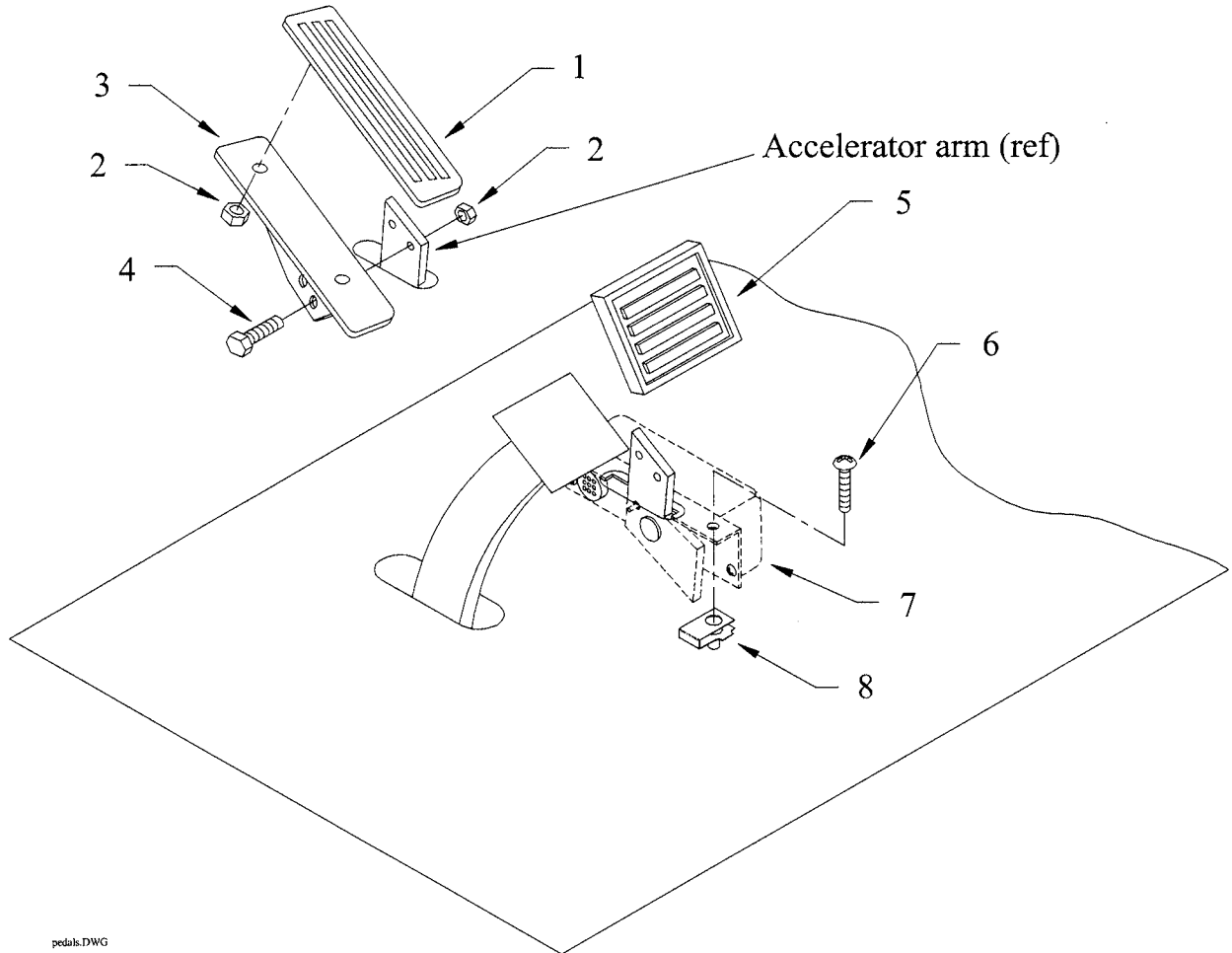

pedals.DWG

ACCELERATOR/BRAKE PEDALS			
ITEM#	PART #	DESCRIPTION	QTY
1	98-254-00	Accelerator Pedal Pad	1
2	88-069-81	1/4" NC Lock Nut	4
3	98-254-25	Accelerator Mounting Plate	1
4	88-060-09	1/4" X 3/4" Hex Bolt	2
5	98-200-00	Brake Pedal Pad	1
6	88-065-08	1/4" X 5/8" Truss Head Screw	2
7	62-033-00	36 Volt Accelerator Module (Standard)	1
8	97-211-20	1/4-NC U-Nut	2

B2-48 Brake Lines and Hoses

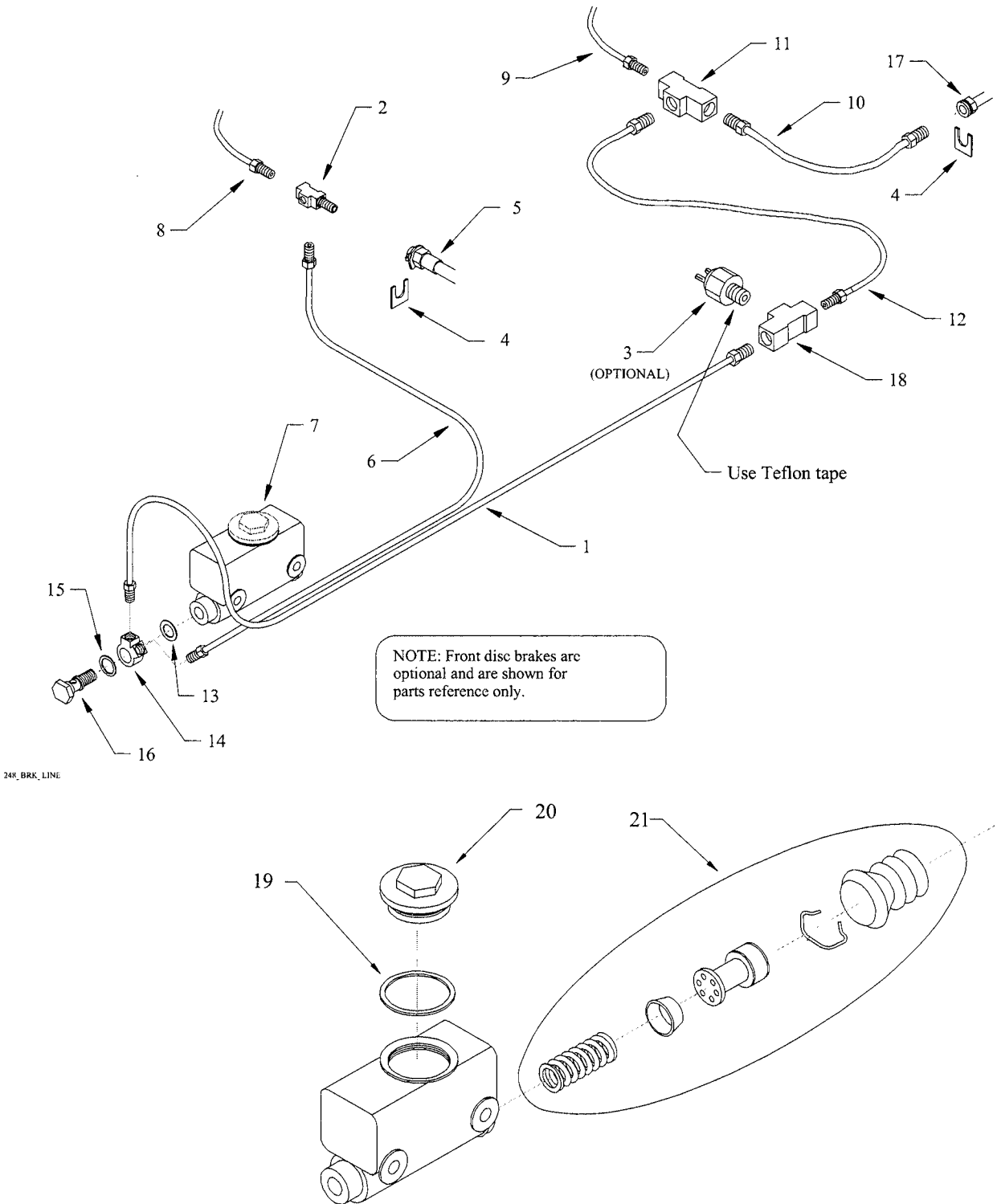

B2-48 BRAKE LINES AND HOSES			
ITEM#	PART #	DESCRIPTION	QTY
1	99-609-51	Brake Line, 3/16" X 72"	1
2*	99-559-02	T-Fitting (For Front Brakes Only)	2
3	71-110-00	Brake Light Switch (Optional)	1
4	99-576-00	Hose Retaining Clip	4
5*	99-580-10	Front Brake Hose (For Front Brakes Only)	2
6*	99-605-56	Brake Line, 3/16" X 60" (For Front Brakes Only)	1
7	99-510-02	Master Cylinder	1
8*	99-606-51	Brake Line, 3/16" X 40", Right (For Front Brakes Only)	1
9	99-604-56	Brake Line 3/16" X 20" Right Rear	1
10	99-604-57	Brake Line 3/16" X 20" Left Rear	1
11	99-564-00	3/16" Union T-Fitting	1
12	99-608-51	Brake Line 3/16" X 60"	1
13	99-572-00	Copper Washer	1
14	99-566-00	Master Cylinder Fitting (One Outlet, Rear Brakes Only)	1
	99-565-00	Y-Fitting (For Front Brakes Only)	1
15	99-571-00	Copper Washer	1
16	99-579-00	Master Cylinder Fitting	1
17	99-580-20	Rear Brake Hose	2
18***	99-575-00	3/16" Union Connector	1
18**	99-591-00	T-Fitting (For Brake Light Switch)	1
19	99-510-53	Cap Gasket	1
20	99-510-52	Cap	1
21	99-510-61	Rebuild kit	1
* - Parts used with front disc brake option only			
** - Part replaces 99-575-00 with the brake light option			
*** - Not shown			

B 2-54 Brake Lines and hoses

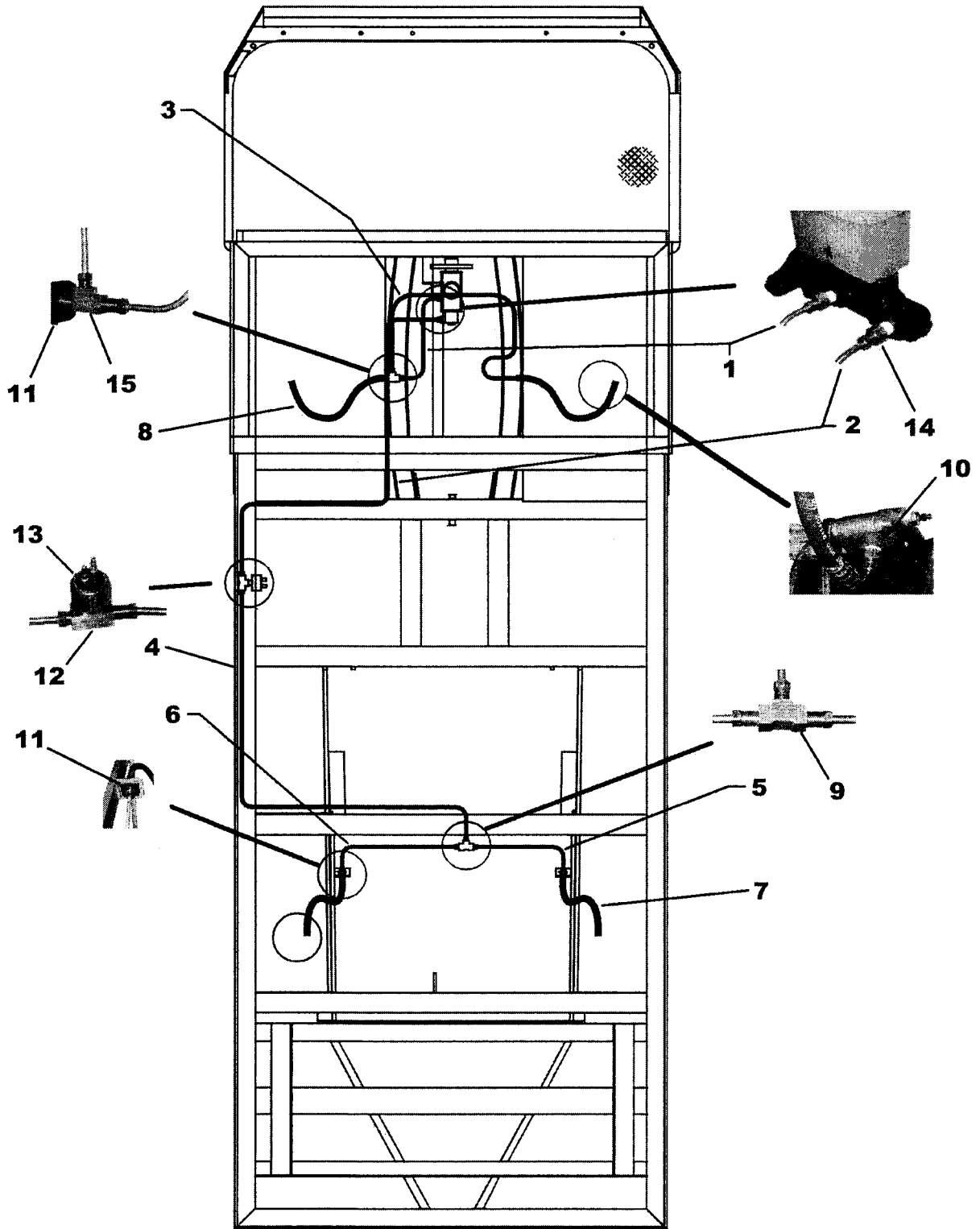

B2-54 BRAKE LINES AND HOSES			
ITEM#	PART #	DESCRIPTION	QTY
1	99-606-56	Brake Line, Front	1
2	99-609-60	Brake Line, Rear	1
3	99-606-51	Brake Line, Front Right	1
4	99-608-51	Brake Line, Rear	1
5	99-604-56	Brake Line, Rear Right	1
6	99-604-57	Brake Line, Rear Left	1
7	99-580-20	Brake Hose, Rear	2
8	99-580-10	Brake Hose, Front	2
9	99-564-00	T-Fitting	1
10	99-575-10	Adaptor, 3/16T X 1/8P	2
11	99-576-00	Hose Clip	4
12a	99-591-00	Brake light switch adaptor (optional)	0 or 1
12b	99-564-00	Union Connecor (standard)	0 or 1
13	71-110-00	Brake Light Switch (optional)	0 or 1
14	99-575-32	Adaptor, 3/16T x M10-1.0	2
15	99-559-00	T-Fitting, Single Male Flare to 2-Female Flare, 3/16 Tube	1

B 2-48 Rear Suspension

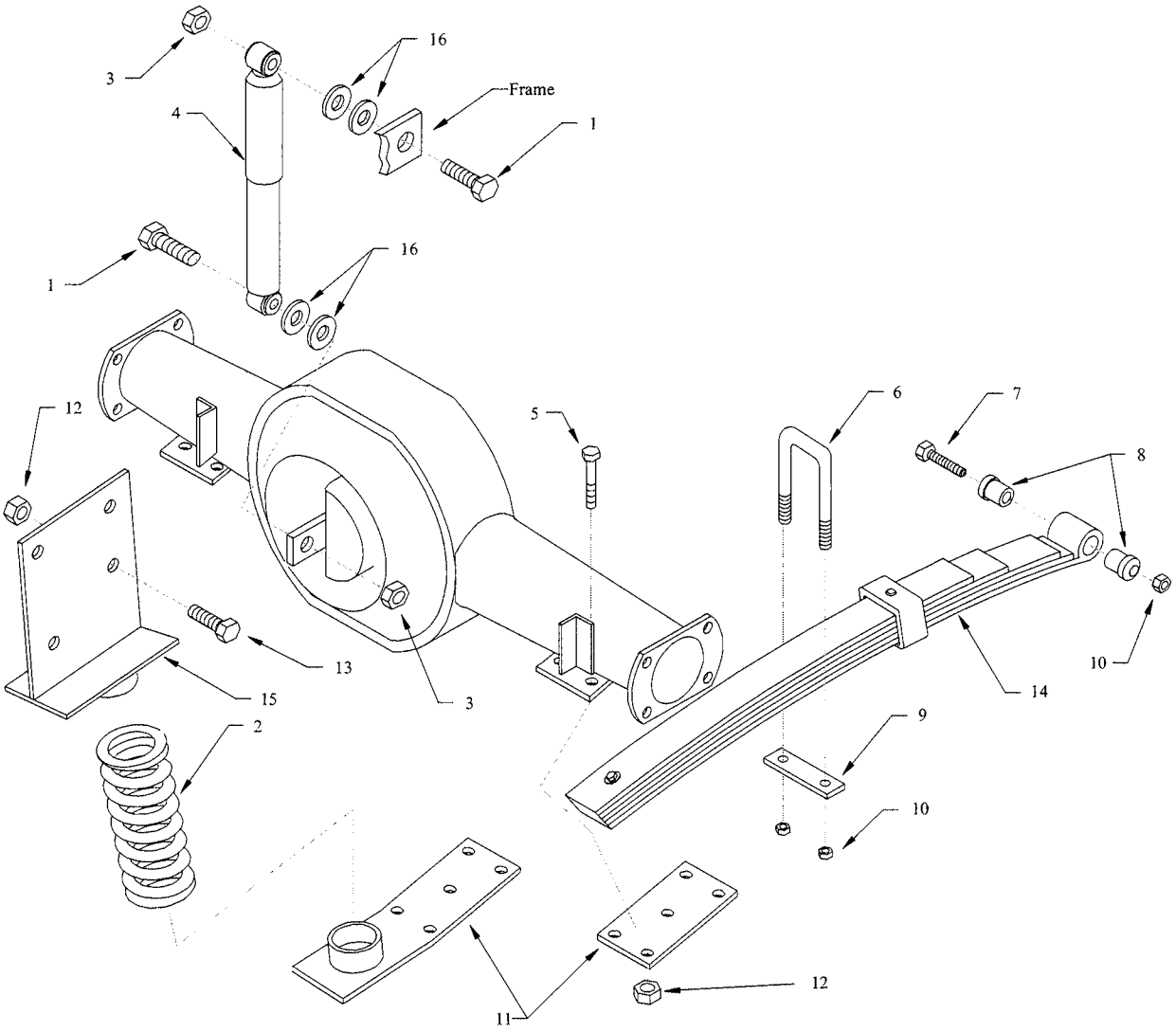

RR_SUSP 248.DWG

B2-48 REAR SUSPENSION			
ITEM#	PART #	DESCRIPTION	QTY
1	88-180-18	5/8" X 1-1/2" Hex Bolt	2
2	85-180-10	Coil Spring (Optional)	1
3	88-189-81	5/8" NC Nylock Hex Nut	3
4	86-000-00	Shock	2
5	88-101-18	3/8" X 2-1/2" Bolt	8
6	96-103-00	U-Bolt	2
7	96-240-00	1/2" NC X 4" Bolt	2
8	32-214-50	Bushing	4
9	50-460-00	Shackle Plate	2
10	88-149-81	1/2" Lock Nut	6
11	16-861-00	Spring Plate	2
	16-864-00	Spring Plate (Overload Spring, Optional)	2
12	88-109-81	3/8" NC Lock Nut, Grade C	14
13	88-100-14	3/8" X 1-1/2" Hex Bolt (Optional)	2
14	85-510-17	Leaf Spring	2
15	16-859-00	Upper Spring Plate (Optional)	2
16	88-188-61	5/8" SAE Flat Washer	4

B2-54 Rear Suspension

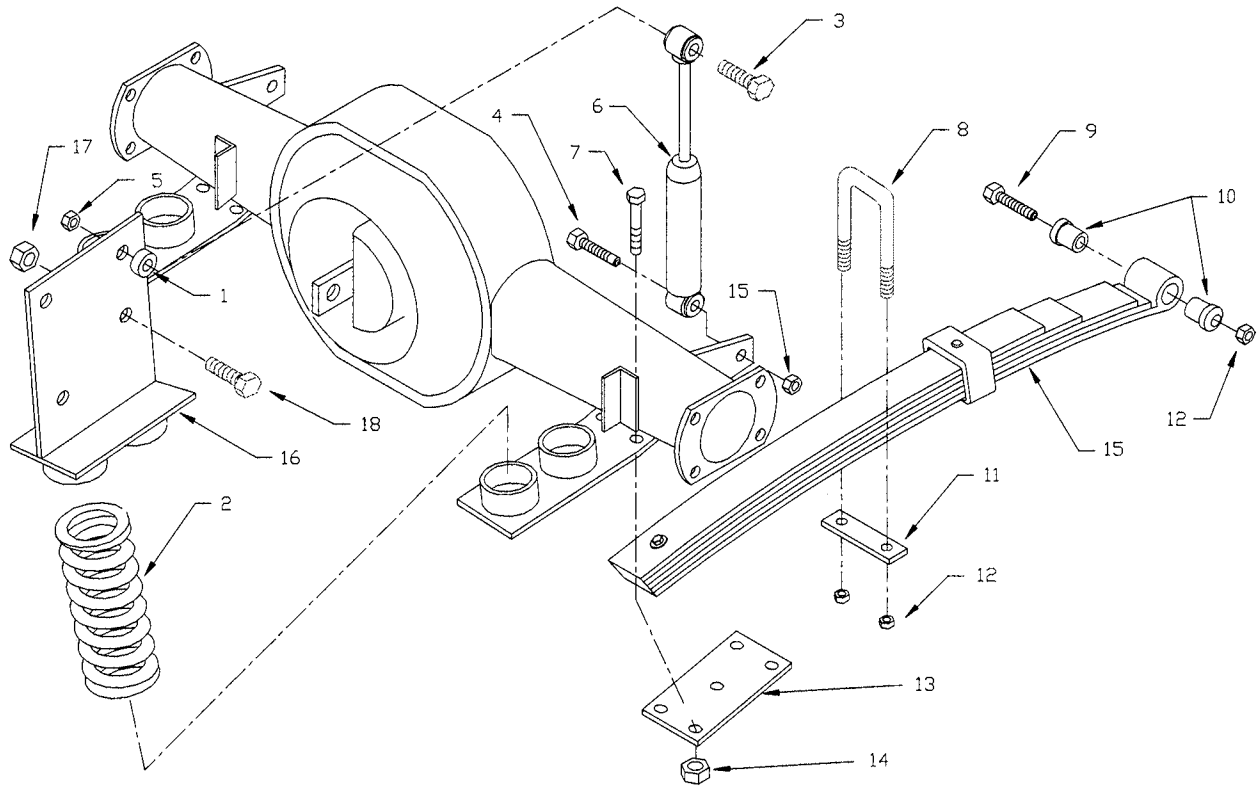

RR_SUSP.DWG

B2-54 REAR SUSPENSION			
ITEM#	PART #	DESCRIPTION	QTY
1	17-106-00	Collar	2
2	85-140-00	Coil Spring	4
3	88-121-19	7/16" X 2-3/4" Hex Bolt, Grade 5	2
4	88-120-17	7/16" X 2-1/4" Hex Bolt, Grade 5	2
5	88-129-81	7/16" Locknut	4
6	86-602-00	Shock	2
7	88-101-18	3/8" X 2-1/2" Bolt	8
8	96-103-00	U-Bolt	2
9	96-240-00	1/2" NC Locknut	2
10	32-214-50	Bushing	4
11	50-460-00	Shackle Plate	2
12	88-149-81	1/2" NC Locknut	6
13	16-874-00	Spring Plate	2
14	88-109-82	3/8" NC Locknut	8
15	85-510-17	Leaf Spring	2
16	16-866-00	Spring Plate Upper Overload Coil	2
17	88-109-81	3/8" Locknut	6
18	88-100-15	3/8" X 1-3/4" Hex Bolt	6

Instument Panel

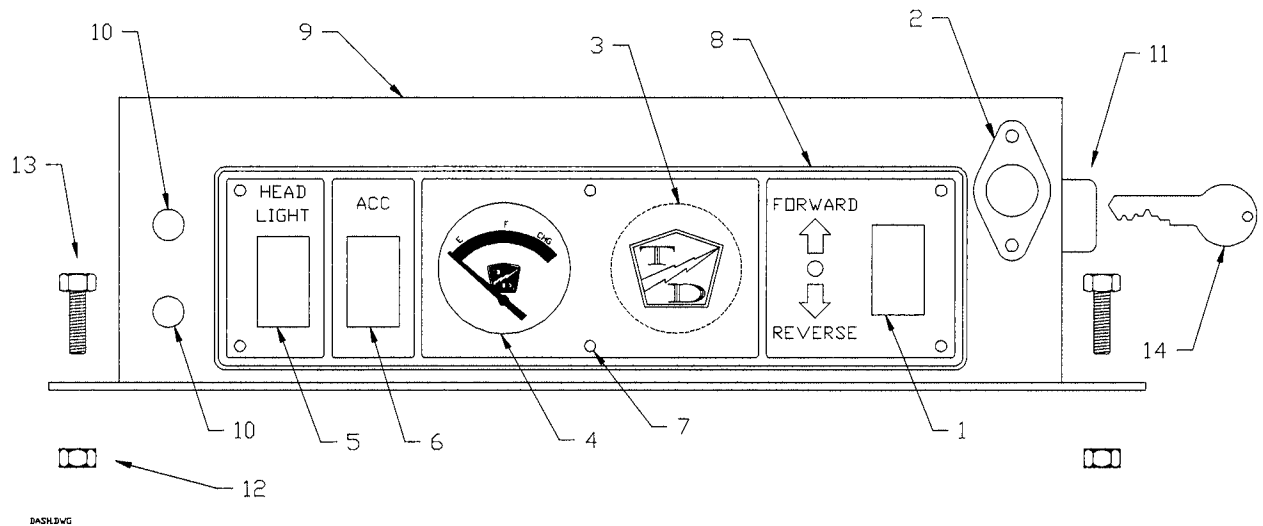

INSTRUMENT PANEL			
ITEM#	PART #	DESCRIPTION	QTY
1	71-039-00	Forward & Reverse Switch	1
2	71-501-00	Horn Button	1
3	74-000-00	Hour Meter (Optional)	1
4	74-009-00	Battery Status Indicator	1
5	71-039-10	Switch, Rocker, 1 Pole, Single Throw, W/Seal	1
6	71-039-20	Hole Plug	1
7	88-817-07	Sheet Metal Screw	6
8	94-304-10	Instrument Panel	1
9	01-200-75	Console	1
10	95-913-00	Hole plug	1
11	71-120-00	Key Switch	1
12	88-069-81	1/4" Nut	2
13	88-065-08	1/4" X 5/8" Phillips Head Bolt	2
14	71-120-80	Keys, Set	1

Frame

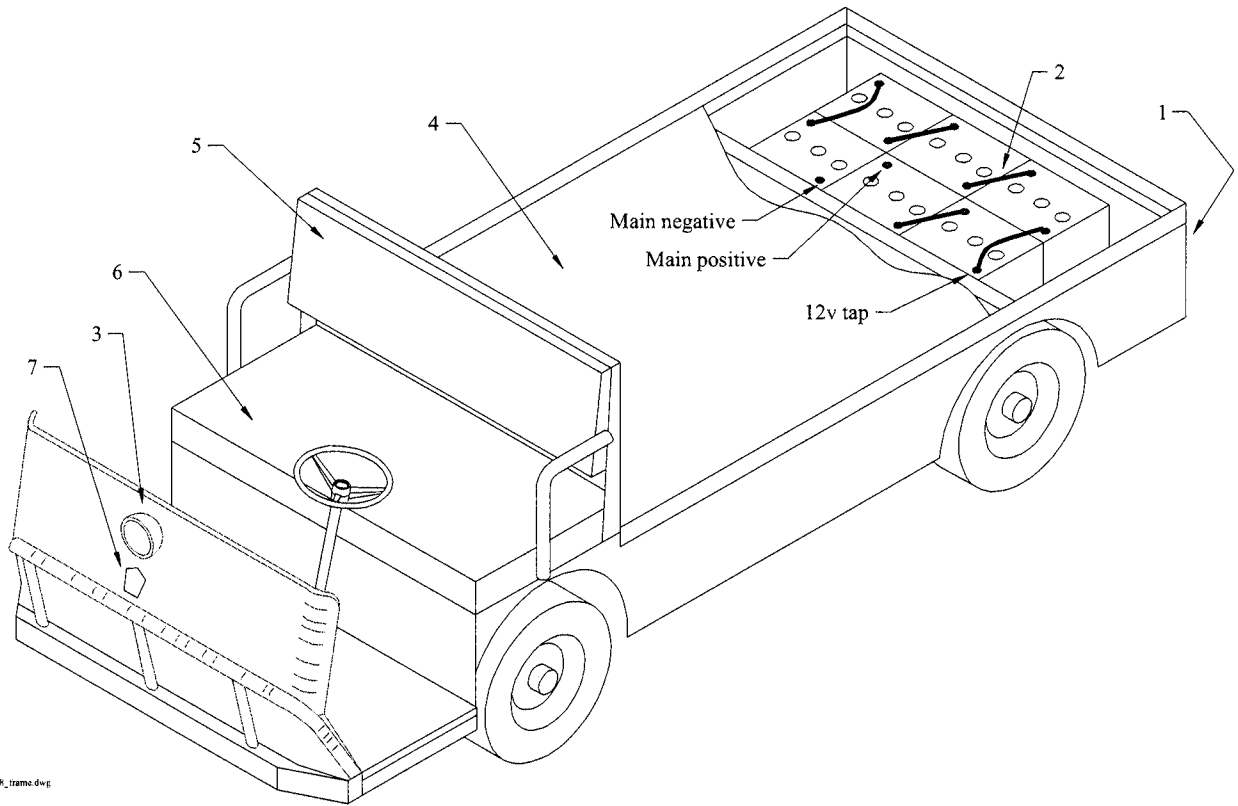

248_frame.dwg

FRAME			
ITEM#	PART #	DESCRIPTION	QTY
1	72-022-00	Tail Light (W/Pigtail and Grommet,) 4" Round, 12Volt	1
2	75-231-00	Battery Jumper, 4 gauge	5
3	72-005-00	Headlight, 4" 12Volt Bulb	1
4	90-444-00	Deckboard (Standard)	1
5	90-140-00	Seat Back Cushion	1
6	90-149-00	Seat Bottom Cushion	1
7	94-201-00	T/D Emblem	1
*	88-567-91	T/D Emblem Fasteners, 6/32" Push On Fastener	3
*	88-837-09	Seat Back Screws	6
	50-243-10	Battery Hold Down Rod	3
	50-250-00	Bat-Lock (battery hold downs)	3
	71-501-00	Horn Button	1
* - Not shown			

Motors

70-057-10
SPEC #- 5BC49JB249B

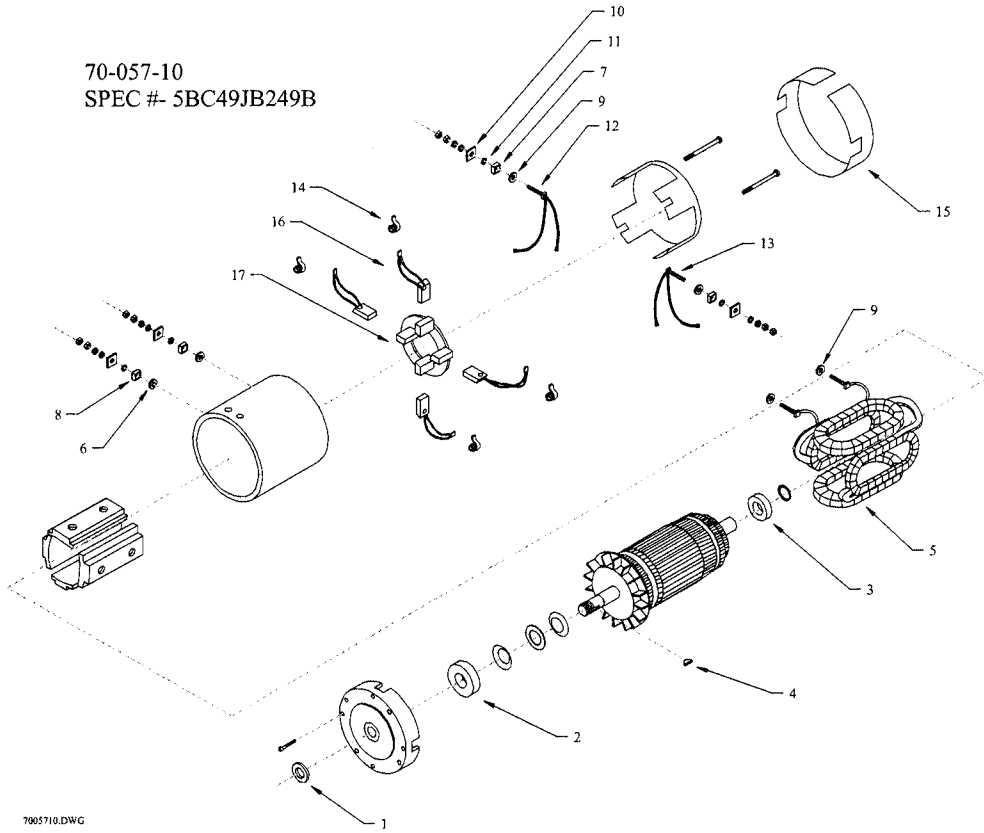

7005710.DWG

70-055-00
SPEC# 5BT1326B262

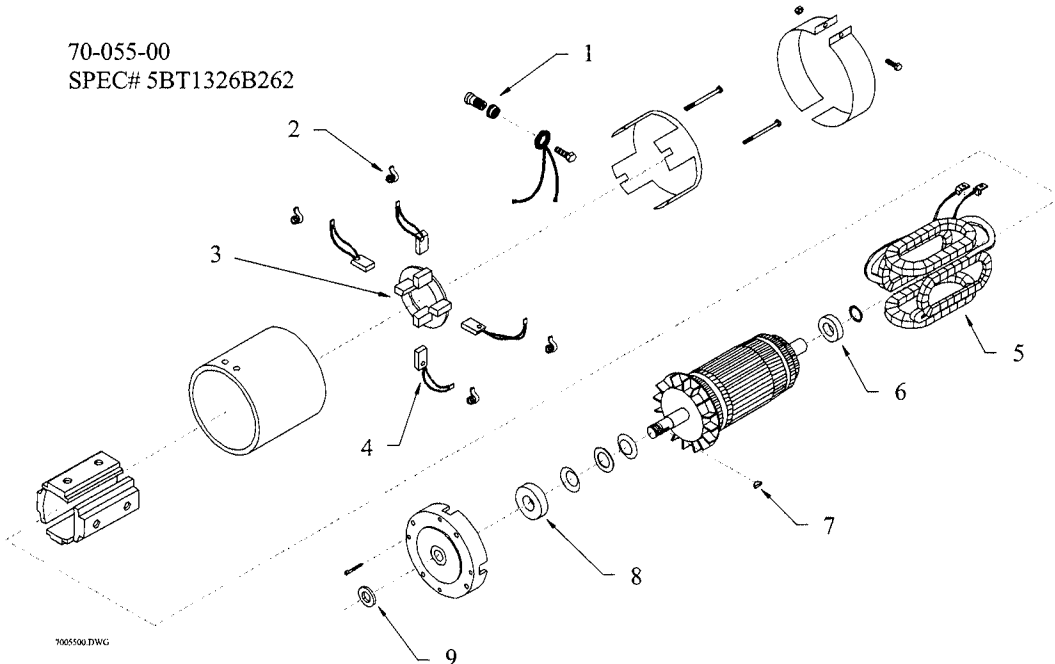

7005500.DWG

MOTOR (STANDARD ON B2-54, OPTIONAL ON B2-48) GE SPEC #5BC49JB249B			
ITEM#	PART #	DESCRIPTION	QTY
1	45-508-00	Seal	1
2	80-504-00	Bearing	1
3	80-214-00	Bearing	1
4	97-100-00	Woodruff Key	1
5	70-209-00	Field Coil Set	1
6	98-623-00	Insulator Bushing	2
7	98-622-0	Insulator Bushing	2
8	97-179-00	Fiber Washer	2
9	97-178-00	Foiber Washer	4
10	97-177-00	Fiber Washer	2
11	70-251-00	Gasket	4
12	70-198-00	Crossover With Terminal	1
13	70-198-01	Crossover With Terminal	1
14	85-413-30	Brush Spring	4
15	30-804-10	Brush Cover	1
16	70-108-00	Brush	4
17	70-176-00	Brush Holder	1
MOTOR (OPTIONAL ON B2-54 AND B2-48) GE SPEC #5BT1326B262			
1	70-210-64	Insulator	4
2	85-398-00	Brush Spring	8
3	70-171-00	Brush Holder	1
4	70-112-00	Brush (Dual Set)	4
5	*	Field Coil	1
7	97-100-00	Key	1
8	80-206-00	Front Bearing	1
9	45-507-00	Seal	1

B2-48 and B2-38 Standard Motor

70-054-00
SPEC #- 5BC49JB399

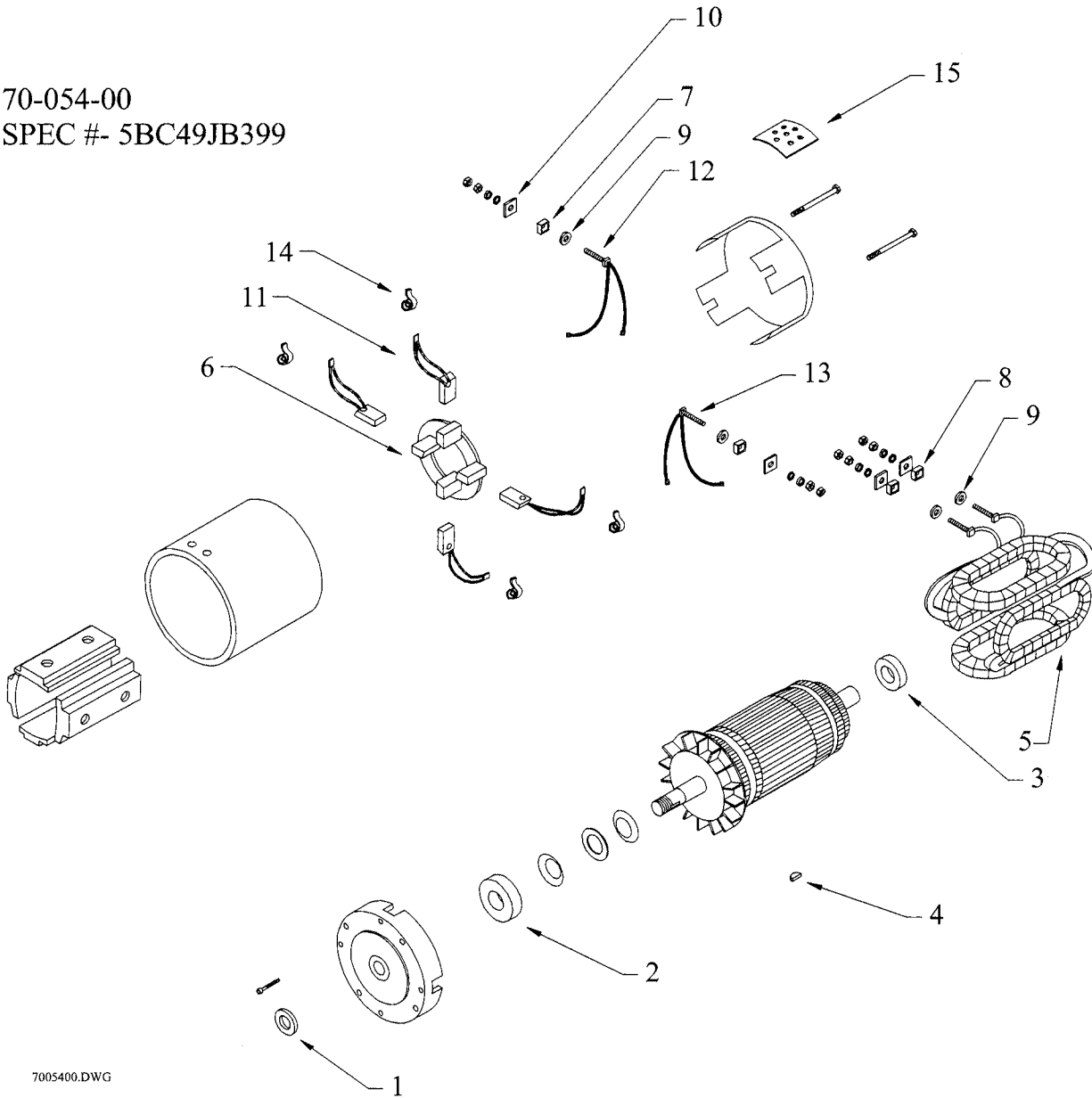

7005400.DWG

B2-48 & B2-38 STANDARD MOTOR (70-054-00)			
GE SPEC #5BJ49JB399			
ITEM#	PART #	DESCRIPTION	QTY
1	45-508-00	Seal	1
2	80-504-00	Beamg	1
3	80-214-00	Bearing	1
4	97-100-00	Woodruff Key	1
5	70-203-10	Field Coil Set	1
6	70-188-00	Brush Holder	2
7	98-622-00	Insulator Bushing	2
8	98-623-00	Insulator Bushing	2
9	97-178-00	Fiber Washer	2
10	97-179-00	Fiber Washer	4
11	70-105-00	Brush	4
12	70-195-10	Crossover with Terminal	1
13	70-195-10	Crossover with Terminal	1
14	85-412-00	Brush Spring	4
15	30-802-00	Brush Cover	4

Rear Axle B2-48

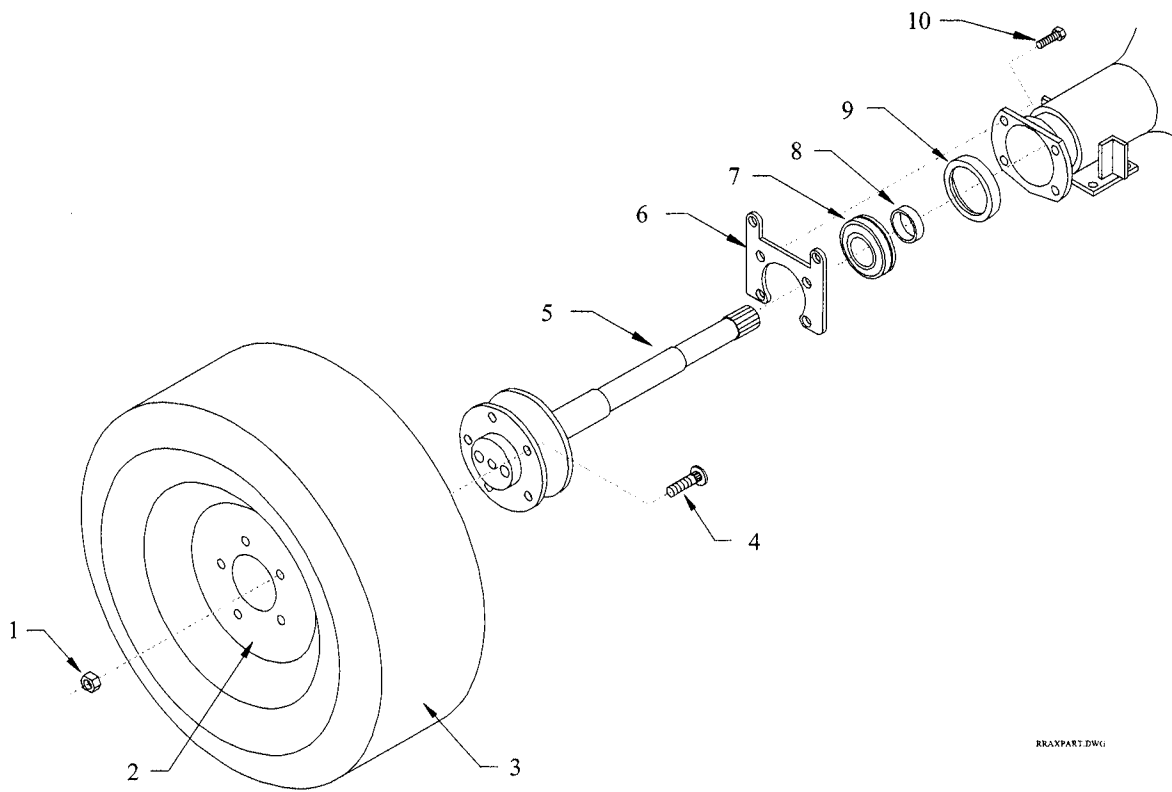

REAR AXLE			
ITEM#	PART #	DESCRIPTION	QTY
1	97-236-00	Wheel Nut	10
2	12-012-00	Wheel	2
3	10-081-00	Tire, 5.70 X 8 Load Range B	2
	13-742-00	Tire/Wheel Assembly, 5.70 X 8 Load Range B	2
4	96-329-10	Wheel Stud	10
5*	41-152-00*	B 2-48/B 2-38 Rear Axle (includes item #4)*	2
5a	41-152-08	B 2-54 Rear Axle (long) (includes item #4)	1
5b	41-152-09	B 2-54 Rear Axle (short) (includes item #4)	1
6	41-350-08	Axle Retaining Bracket	2
7	80-503-00	Bearing	2
8	32-515-00	Bearing Retainer	2
9	45-301-00	Seal	2
10	96-328-00	Axle Mounting Bolt	8
*	41-152-10	Rear Axle Assembly (includes item #'s 4, 5, 7, 8, 9)	2

Rear Axle B2-54

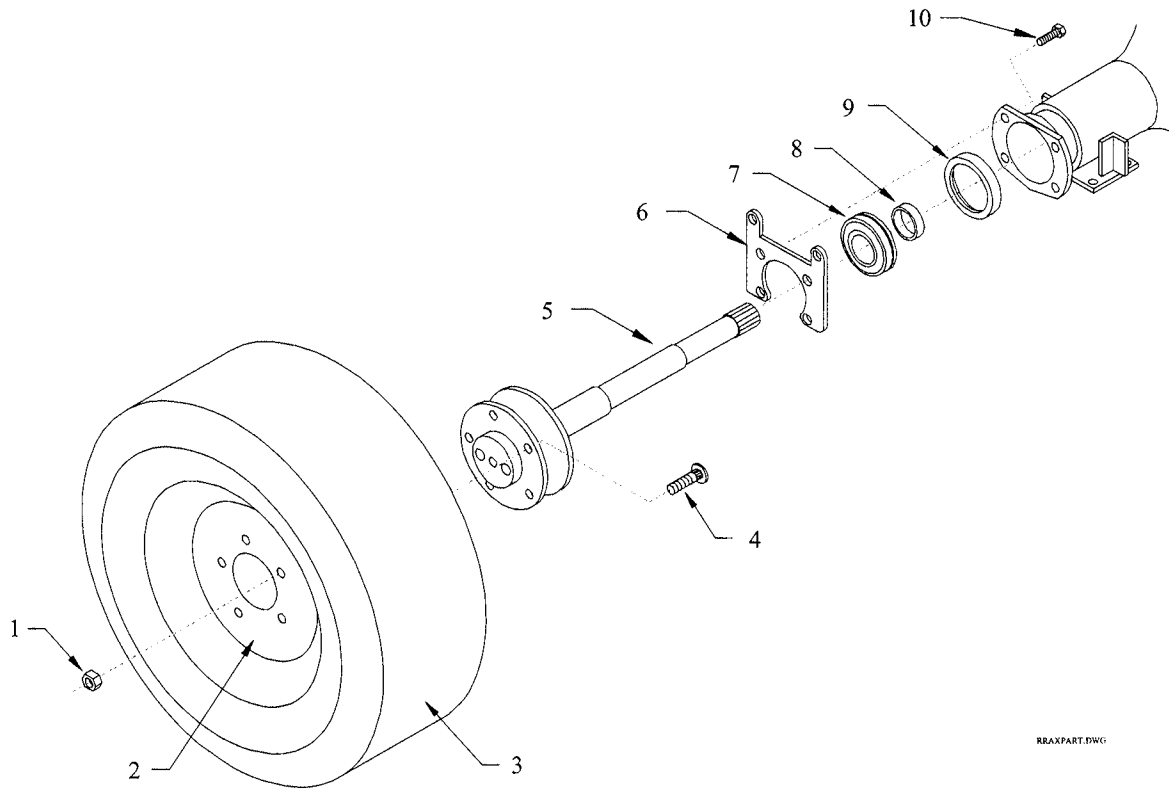

B2-54 REAR AXLE			
ITEM#	PART #	DESCRIPTION	QTY
1	97-236-00	Wheel Nut	10
2	12-055-10	Wheel, Cast Iron, 5 Hole, 14" od.	2
3	10-262-00	Tire, 18 X 5 X 14 Smooth	2
	13-957-11	Tire/Wheel Assembly, 18 X 5 X 14 Smooth, 5 Holes	2
4	96-329-10	Wheel Stud, 1/2" X 1-5/8"	10
5	41-152-08	Left Rear Axle, 21-3/8" (includes item#4)	1
	41-152-09	Right Rear Axle, 12-1/4" (includes item#4)	1
6	41-350-08	Axle Retaining Bracket	2
7	80-503-00	Bearing, Ball, Rear Axle Large	2
8	32-515-00	Retainer Ring, Large Bearing	2
9	45-301-00	Seal, Oil, Rear Axle Bearing	2
10	96-328-00	Axle Mounting Bolt	8

3rd Member and Axle Assembly

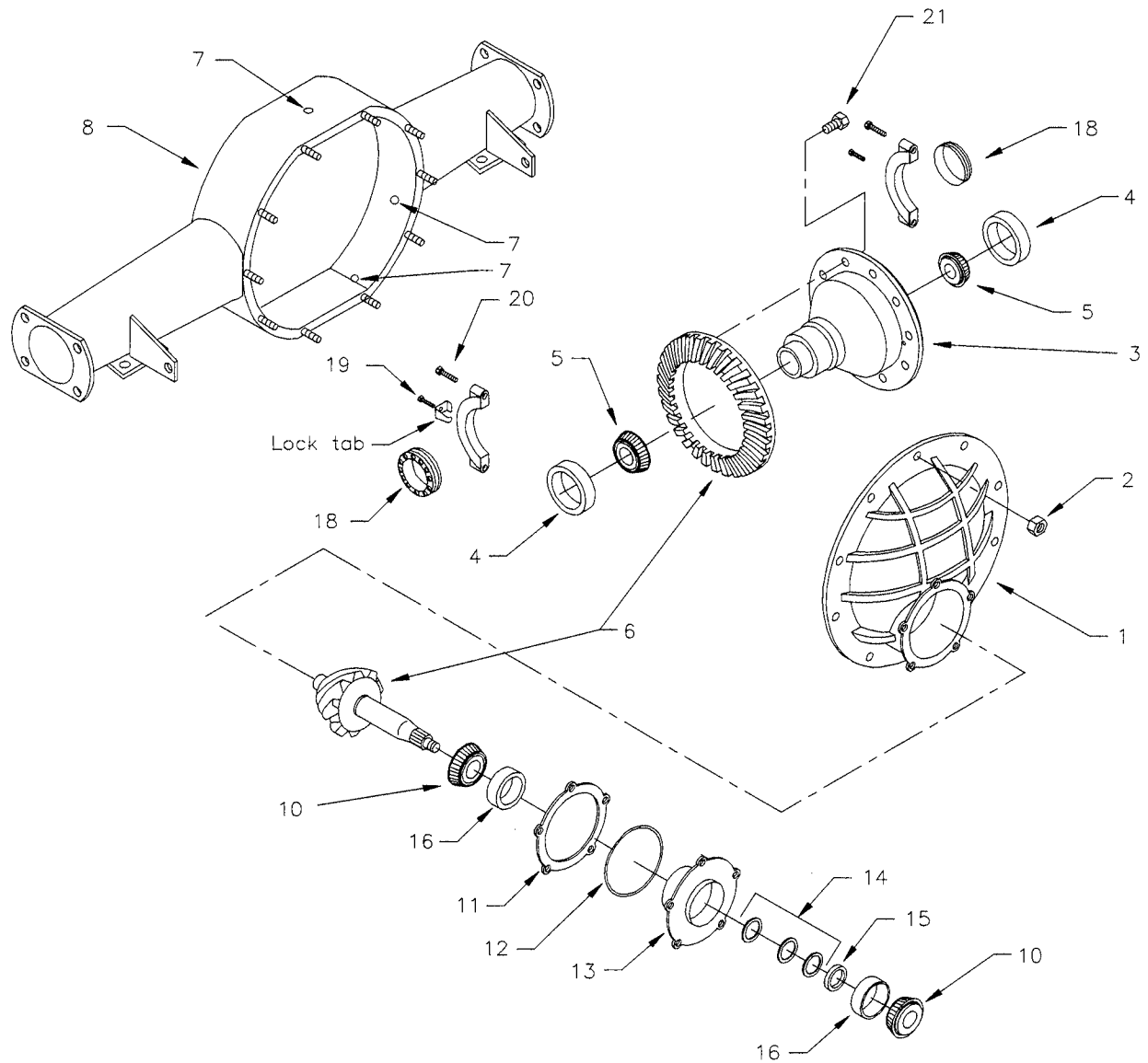

3RD MEMBER & AXLE ASSEMBLY			
ITEM#	PART #	DESCRIPTION	QTY
1	41-179-00	3rd member Housing (1.628 ID Carrier Bearing)	0 or 1
	41-710-00	3rd member Housing (1.784 ID Carrier Bearing)	0 or 1
2	88-119-80	3/8" NF Nut	14
3	41-712-00	Differential Assembly (1.628 ID Carrier Bearing)	0 or 1
	41-713-00	Differential Assembly (1.784 ID Carrier Bearing)	0 or 1
4	80-127-00	Carrier Bearing Race, (For 1.628 ID Carrier Bearing)	0 or 2
	80-128-00	Carrier Bearing Race, (For 1.784 ID Carrier Bearing)	0 or 2
	80-129-00	Carrier Bearing Race, (For P/N 80-513-00)	0 or 2
5	80-511-00	Carrier Bearing (1.628 ID Carrier Bearing)	0 or 2
	80-512-00	Carrier Bearing (1.784 ID Carrier Bearing)	0 or 2
	80-513-00	Carrier Bearing (1.7812 ID Carrier Bearing)	
6	31-239-00	Ring and Pinion Gear Set (5.43)	0 or 1
	31-234-00	Ring and Pinion Gear Set (3.00)	0 or 1
	31-275-00	Ring and Pinion Gear Set (2.75)	0 or 1
7	41-997-00	Oil Plug	3
8	41-291-32	Rear End Housing (For B2-48 & B2-38)	1
	41-299-20	Rear End Housing (For B2-54)	1
10	80-554-00	Front Pinion Bearings	
11	41-711-00	Pinion Housing Shim	1
12	80-702-00	O-Ring	1
13	44-340-90	Pinion Housing	1
14	16-419-00	.002 Shim (Add Shims As Needed)	*
	16-420-00	.010 Shim (Add Shims As Needed)	*
	16-411-00	.005 Shim (Add Shims As Needed)	*
15	16-415-00	Spacer	1
16	80-125-00	Pinion Bearing Race	2
18	41-707-00	Differential Bearing Adjuster Nut (For 80-511-00)	0 or 2
	41-707-50	Differential Bearing Adjuster Nut (For 80-512-00)	0 or 2
	41-708-50	Differential Bearing Adjuster Nut (For 80-513-00)	0 or 2
19	88-080-04	5/16" X 3/8: NC Hex Bolt	2
20	88-140-16	1/2" X 2" Hex Bolt	2
21	96-243-00	7/16" X 7/8" Hex Bolt (Locking Head)	10

Power Traction Assembly

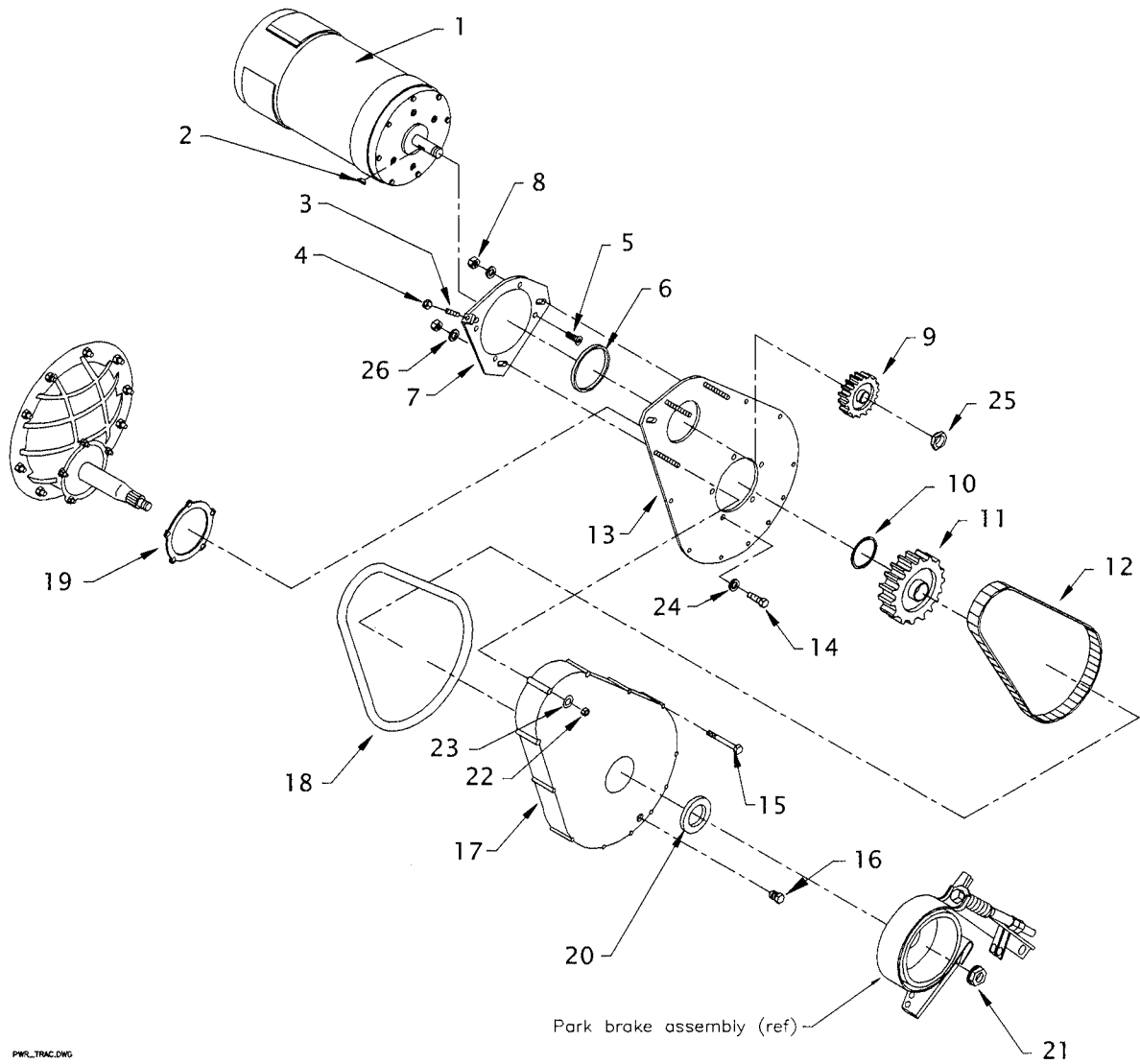

PWR_TRAC.DWG

POWER TRACTION			
ITEM#	PART #	DESCRIPTION	QTY
1	70-055-00	Motor (Optional on B2-48 & B2-54)	1
	70-057-10	Motor (Optional on B2-48 & Standard on B2-54)	1
	70-054-00	Motor (Standard on B2-48 & B2-38)	1
2	97-100-00	Woodruff Key	1
3	88-087-11	Chain Adjusting Screw	1
4	88-069-80	5/16" NC Hex Nut	1
5	88-103-09	Motor Mounting Screw, 3/8" X 3/4" NC	4
6	80-703-00	O-Ring, 4-1/2" ID X 5" OD	1
7	70-454-00	Motor Mounting Plate	1
8	88-109-87	3/8" KEPS Nut (Interegral Lockwasher)	3
9	30-070-00	15 Tooth Double Motor Sprocket (Standard on B2-54)	1
	30-081-00	14 Tooth Single Motor Sprocket (Standard on B2-48)	1
	30-080-00	15 Tooth Single Motor Sprocket (Optional)	1
10	16-415-00	Spacer Main Sprocket, F2 Axle, .440" Thick	1
11	30-070-10	81 Tooth Double Pinion Sprocket (Standard on B2-54)	1
	30-093-00	81 Tooth Single Pinion Sprocket (Standard on B2-48)	1
12	30-320-11	Drive Chain, 15-81 T Dble Sprockets (Standard B2-54)	1
	30-508-20	Drive Chain, 15-81 T Sgl Sprockets (Standard B2-48/38)	1
13	44-352-53	Backing Plate, Gear Case	1
14	88-101-13	3/8" X 1-1/4" NC Hex Bolt	5
15	88-080-20	5/16" X 3" Hex Bolt	9
16	41-989-00	Drain and Fill Plug	2
17	43-201-11	Chain Cover	1
18*	45-002-00	Chain Case Gasket	1
19*	45-021-00	Backing Plate Gasket	1
20	45-331-00	Pinion Oil Seal, Gear Case	1
21	97-250-00	Pinion Nut	1
22	88-089-81	5/16" NC Locknut	12
23	88-088-61	5/16" SAE Flat Washer	3
24	88-108-63	Internal Tooth Lock Washer	5
25	88-239-82	Motor Nut, 3/4" NF Hex Jam Nut, Thin	1
26	88-109-61	3/8" SAE Flat Washer	3

* - No longer used on late model trucks. Replaced with Ultra-Blue RTV sealant 94-430-03

Control Panel B2-38 and B2-48

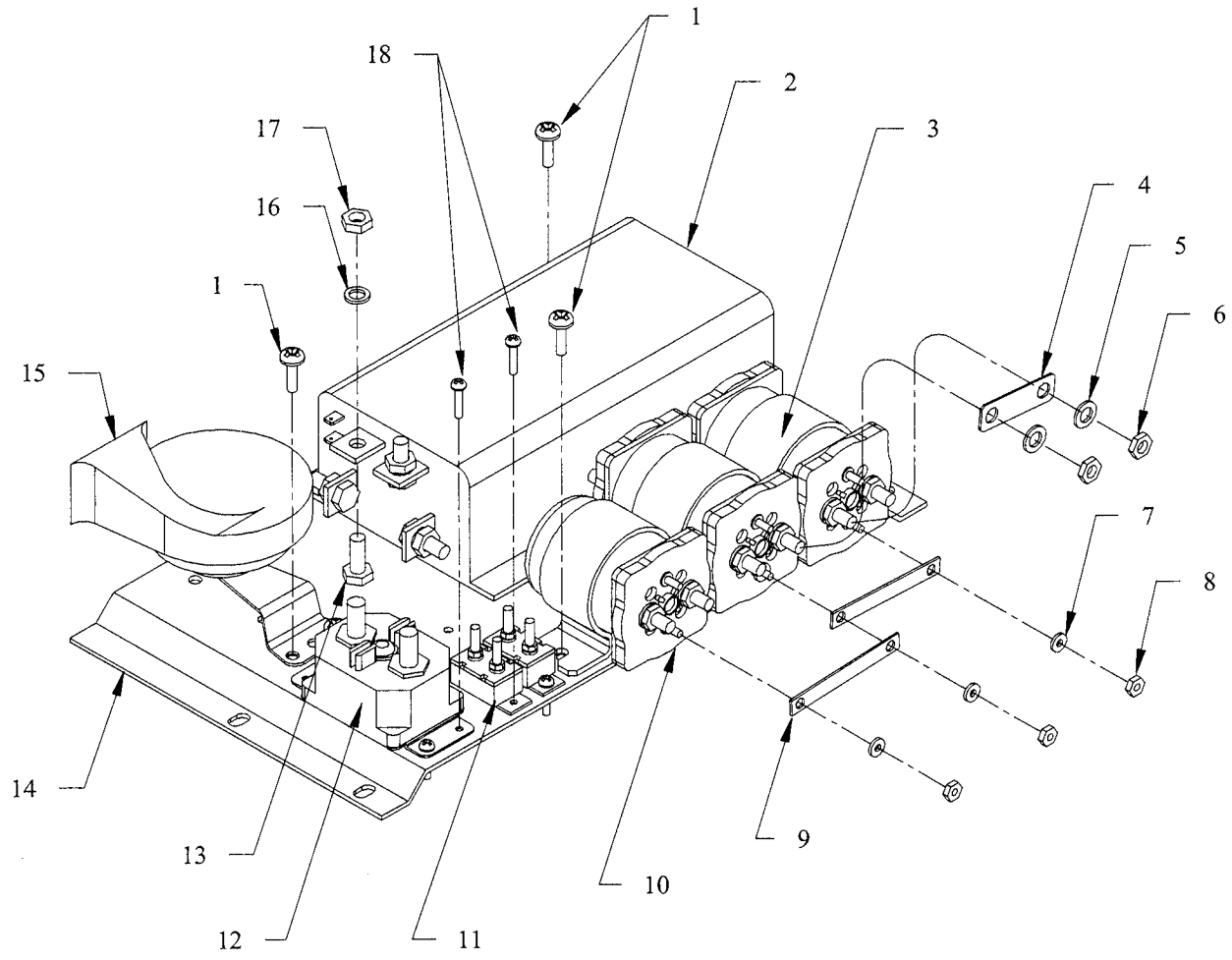

B2-48 CONTROL PANEL			
ITEM#	PART #	DESCRIPTION	QTY
1	88-838-06	#14 X 1/2" Sheet Metal Screw	10
2	62-205-00	PMC Speed Control	1
3	72-501-39	Forward/Reverse Solenoid, 36Volt, 200Amp	2
4	61-838-41	Buss Bar	2
5	88-088-63	5/16" Internal Tooth Lock Washer	10
6	88-099-91	5/16" NF Jam Nut	10
7	88-048-60	#10 Split Lock Washer	6
8	88-049-80	10-32 Hex Nut	6
9	61-838-42	Buss Bar	2
10	72-501-38	ISO Solenoid, 36Volt, 200Amp	1
11	79-840-00	Circuit Breaker	2
12	79-844-20	200Amp Circuit Breaker	1
13	88-080-11	5/16" Hex Bolt	4
14	01-534-80	Mounting Plate	1
15	73-004-20	Horn	1
16	88-088-62	5/16" Split Lock Washer	4
17	88-089-80	5/16" NC Hex Nut	4
18	88-818-06	#8 X 1/2" Sheet Metal Screw	4
Not Shown	75-149-26	Power Harness	1
	75-148-25	Control Panel Harness	1

Control Panel B2-54

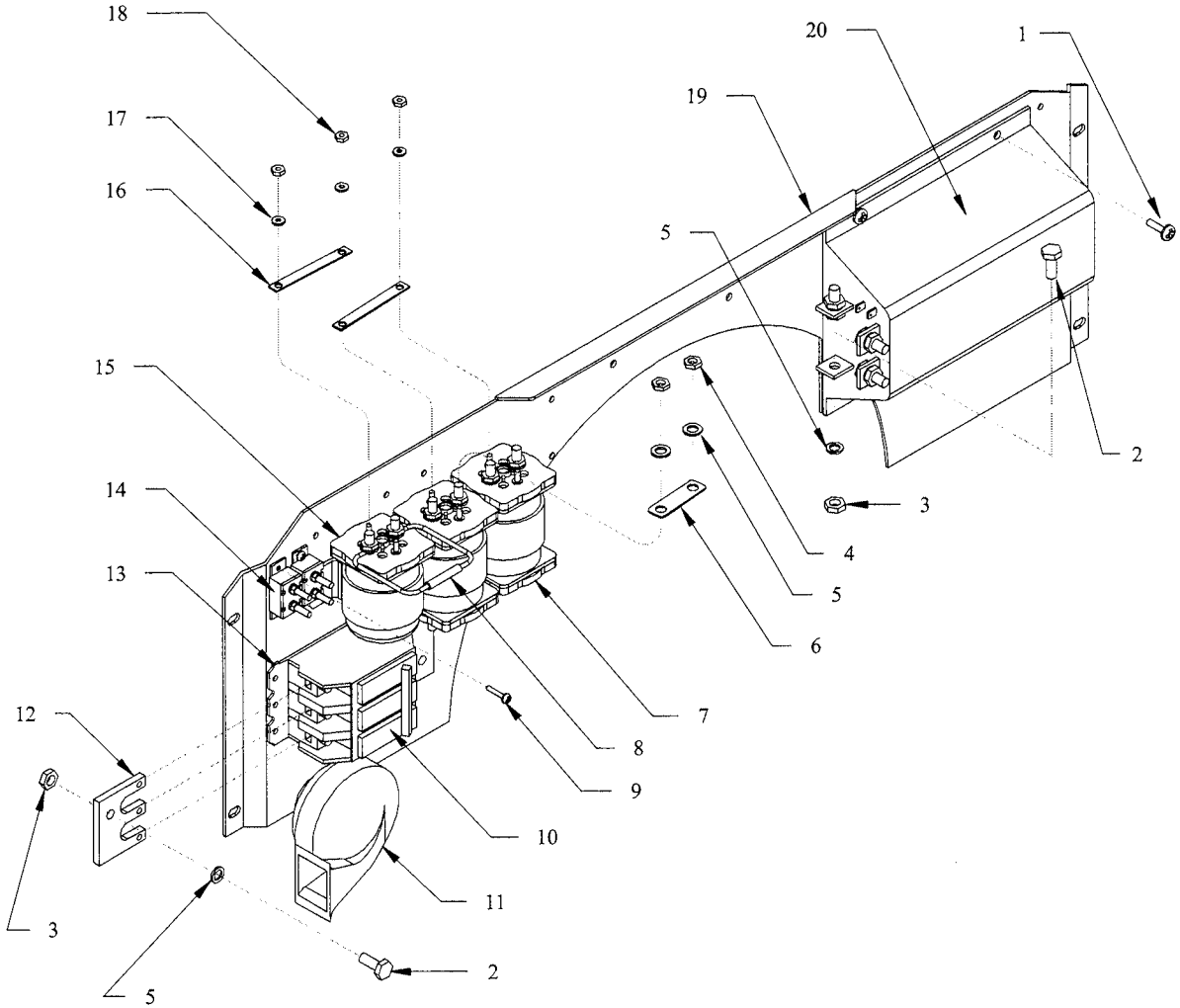

B2-54 CONTROL PANEL			
ITEM#	PART #	DESCRIPTION	QTY
1	88-838-06	Mounting Screw, #14 Pan Head	10
2	88-080-11	5/16" X 1" Hex Head Cap Screw	6
3	88-089-80	5/16" NC Hex Nut	2
4	88-099-91	5/16" Jam Nut	10
5	88-088-62	5/16" Split Lockwasher	14
6	61-838-41	Buss Bar, 3/8" X 2-5/8"	2
7	72-501-39	Reverse Solenoid, SPDT, 36 Volt, 200Amp	2
8	78-302-50	Resistor, 250 OHMS, 5 Watts	1
9	88-818-06	#8 Pan Head Screw	10
10	79-843-11	Circuit Breaker, 100 Amp, 3-Pole	1
11	73-004-20	Horn, 12V	1
12	78-107-00	Circuit Breaker Buss Bar	2
13	71-610-03	Circuit Breaker Mounting Plate	1
14	79-840-00	Circuit Breaker, 10 Amp	2
15	72-501-38	ISO Solenoid, SPST, 36 Volt, 200 Amp	1
16	61-838-42	Buss Bar, 5/8" X 1-1/2"	2
17	88-048-62	#10 Lockwasher	6
18	88-049-80	10-32 Hex Nut	6
19	01-254-00	Control Panel Mounting Plate	1
20	62-205-40	PMC Speed Control	1
Not Shown	75-148-25	Control Panel Harness	1
	75-149-26	Power Harness	1

Charger

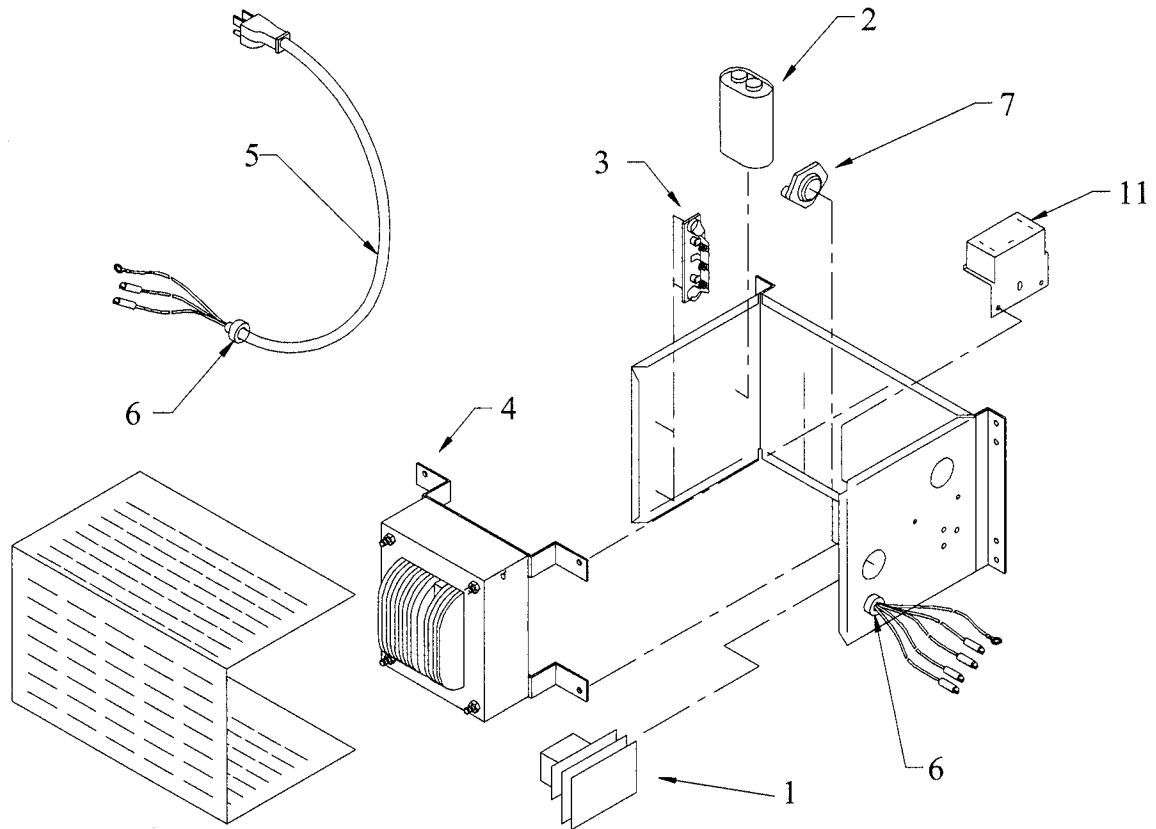

B2-48/38 & B2-54 STANDARD CHARGER (SPEC # 22740)			
ITEM#	PART #	DESCRIPTION	QTY
	79-303-15	Complete Charger, Les2, 36 Volt, 25 Amp. 115/60	1
1	79-805-67	Timer Assembly	1
2	79-902-00	Capacitor	1
3	79-749-13	Diode Assembly	1
4	79-644-31	Transformer	1
5	79-575-30	AC Cord	1
6	79-530-00	Bushing	1
7	79-831-00	Fuse	1
11	79-809-60	Interlock Relay	1
Not Shown	79-511-00	Cord Holder	1
	76-200-00	Replacement Plug	1
B2-48/38 & B2-54 OPTIONAL CHARGER (Spec # 22640)			
	79-303-20	Complete Charger, Les2, 36 Volt, 40 Amp, 115/60	1
1	79-805-67	Timer Assembly	1
2	79-902-00	Capacitor	1
3	79-749-13	Diode Assembly	1
4	Special order	Transformer	1
5	79-575-30	AC Cord	1
6	79-530-00	Bushing	1
7	79-831-00	Fuse	1
11	79-809-50	Interlock Relay	1
Not Shown	79-511-00	Cord Holder	1
	76-200-00	Replacement Plug	1

Miscellaneous Electrical System Parts

No Illustration Available

ELECTRICAL SYSTEM PARTS		
PART #	DESCRIPTION	QTY
71-120-00	Key-Switch	1
71-110-00	Brake Light Switch	1
71-039-10	Light Switch	1
71-039-00	Forward/Reverse Switch	1
72-148-29	Truck Control Harness	1
72-072-00	Head Light Bulb	2
94-005-00	Head Light Assembly	1
72-051-00	Front Turn Signal Bulb	2
72-022-00	Tail/ Stop Light with Rubber Gasket & Pigtail	2
74-000-00	Hour Meter (Optional)	1
74-009-00	Battery Status Indicator	1
71-900-05	Signal Flasher (Optional)	1
71-141-20	Turn Signal Switch (Optional)	1

Decals

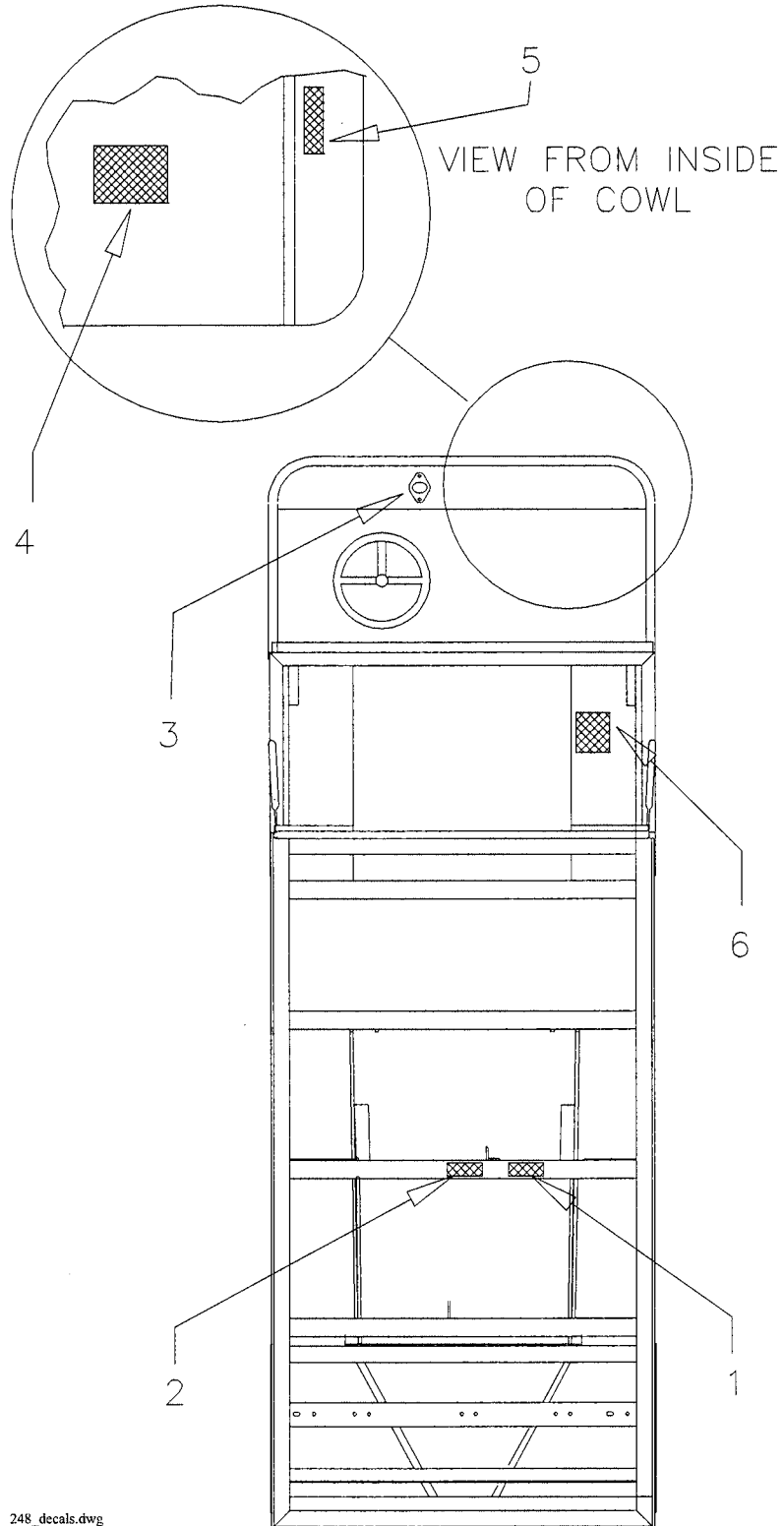

248_decals.dwg

DECALS			
ITEM#	PART #	DESCRIPTION	QTY
1	94-313-00	Decal, Battery Warning	1
2	94-319-00	Decal, Battery Disconnect	1
3	71-501-00	Horn Button	1
4	94-313-20	Decal Safety Warning	1
5	94-309-00	Decal, Brake Warning	1
6	94-373-10	Decal, Vehicle Data	1

TAYLOR - DUNN

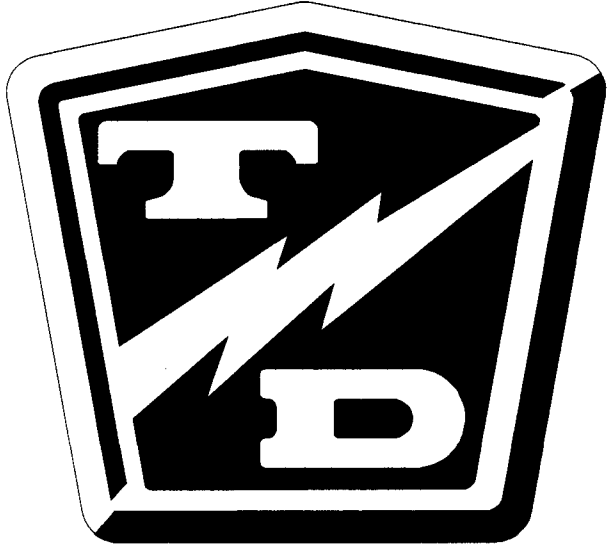

APPENDIX A-Special Tools

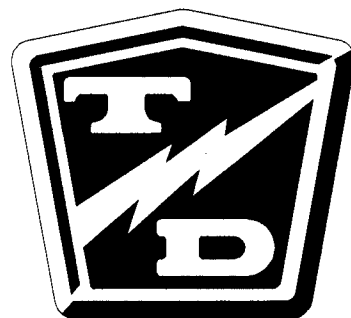

Special Tools

DESCRIPTION	PURPOSE	PART NUMBER
Pinion Seal Installation Tool	Used to install the pinion seal on all chain drive trucks with the band style brake or the speed sensor on the chain case cover.	43-201-50
Chain Case Centering Tool	Used to center the chain case on the pinion shaft on all chain drive trucks with the band style brake or the speed sensor on the chain case cover. Includes instructions.	41-532-50
Test Light	Used for testing electrical circuits. Powered by the truck batteries, switchable for 12, 24, 36, and 48 volts.	62-027-00
Accelerator Test Harness	Used to test the solid state accelerator module part number series 62-033-XX.	62-027-31
PMC Test Kit	Includes 62-027-00, 62-027-31, and supplementary troubleshooting manual M3-001-06. For controllers equipped with pins labeled KSI and #2 only.	62-027-60
Curtis PMC Handheld Programmer	Used to test and program the 62-215-00 PMC speed control used on early model C4-25 Huskey.	62-027-10
GE EV1 Analyzer	Used to test the GE EV1 speed control.	62-027-20
Disc Brake Boot Installation Tool	Used to install the rubber boot on all disc brake bodies.	41-350-13
Pin Removing Tool	Used to remove pins and sockets from AMP connectors.	75-440-55
Pin Removing Tool	Used to remove pins and sockets from MOLEX connectors.	75-442-55
Hydrometer	Used to check the specific gravity of battery electrolyte.	77-200-00
Battery Filler	Used to safely add water to batteries.	77-201-00
Retaining Plate Depressor	Used to hold down the retaining plate when disassembling the steering gear on trucks equipped with the tilt steering.	96-500-39
Fork Collar Weld Jig	Used when replacing the fork collar on models MX-600 and SS5-36.	96-500-40
Secondary Sheave Holder	Used to hold the secondary sheave (pulley) from turning on models R6-80 and B6-10 with the Yamaha drive.	96-500-14
Solder Kit For Field Stud	Used to solder the aluminum field wire to the field stud. For use on motors with soldered connections only.	70-210-63
Pinion Gear Holding Tool	Used to align the Pinion Gear and Case during assembly and disassembly.	96-500-42

TAYLOR - DUNN

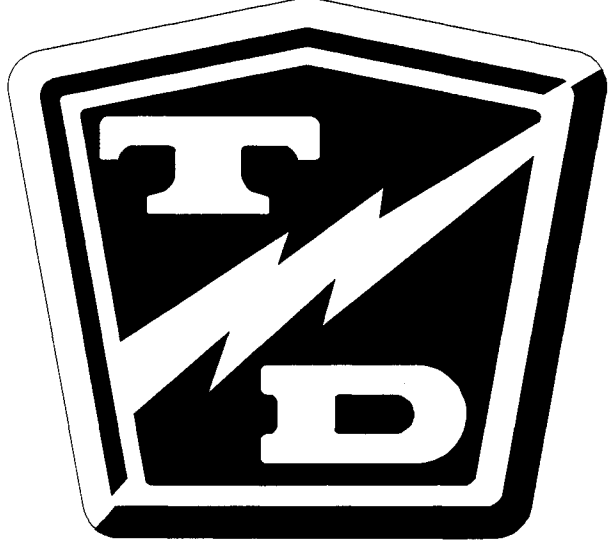

APPENDIX B-Torque Values

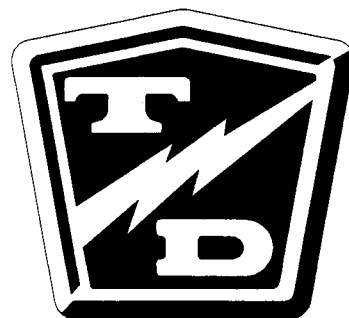

Recommended Torque Values Chart

Diameter and TPI	Grade 2 Tightening Torque (ft-lb)	Grade 5 Tightening Torque (ft-lb)	Grade 8 Tightening Torque (ft-lb)	L'9 Tightening Torque (ft-lb)
1/4-20	4-7	7-10	10-14	11
1/4-28	5-8	8-12	11-16	12
5/16-18	9-14	14-21	20-29	22
3/8-16	16-24	25-37	35-52	25
3/8-24	18-27	28-42	40-59	45
7/16-14	26-38	40-59	56-84	65
7/16-20	29-43	44-66	62-93	70
1/2-13	39-59	60-90	85-128	95
1/2-20	44-66	68-102	96-144	110
9/16-12	56-84	87-131	123-184	140
9/16-18	63-94	97-146	137-206	160
5/8-11	78-117	120-180	170-254	195
5/8-18	88-132	136-204	192-288	225
3/4-10	138-207	213-319	301-451	350
3/4-16	154-231	238-357	336-504	390
7/8-9	222-334	344-515	485-728	565
7/8-14	245-367	379-568	534-802	625
1-8	333-500	515-773	727-1091	850
1-14	373-560	577-866	815-1222	930
1.125-7	472-708	635-953	1030-1545	1700
1.125-12	530-794	713-1069	1156-1733	1850
1.25-7	666-999	896-1344	1454-2180	2950
1.25-12	738-1107	993-1489	1610-2414	3330

Head Markings

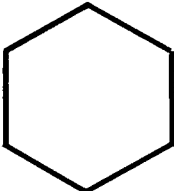

S.A.E. Grade 2

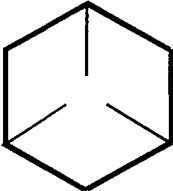

S.A.E. Grade 5

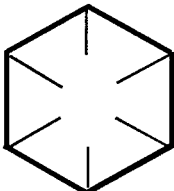

S.A.E. Grade 8

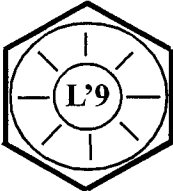

L'9

The following bolts are in accordance with Grade 2 torque values

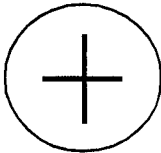

Truss Head
1/4-20

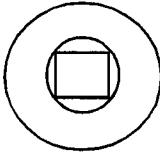

Carriage Bolt
5/16-18 & 3/8-16

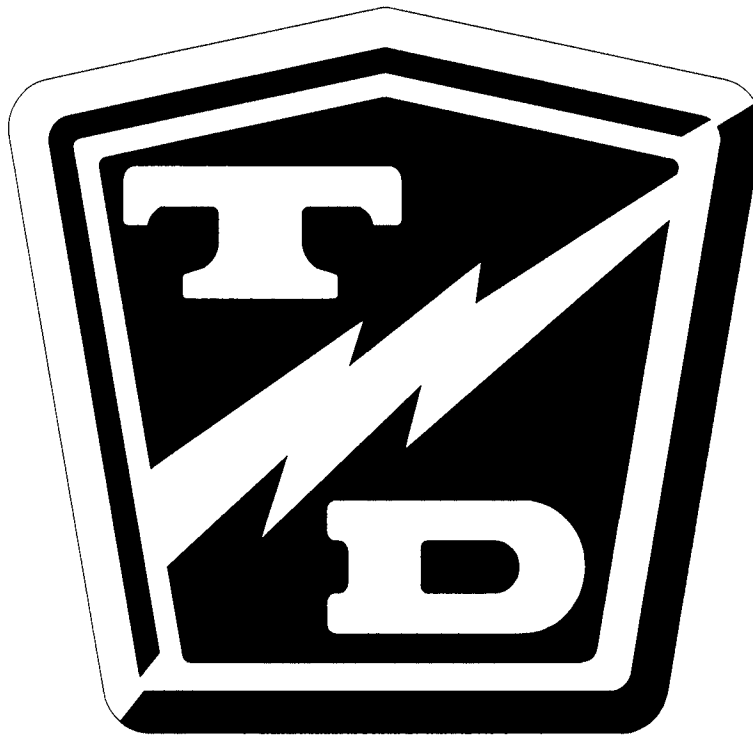

Taylor-Dunn® Mfg.
2114 W. Ball Rd.
Anaheim, CA 92804
(800)-688-8680
(714) 956-4040
(FAX) (714) 956-0504

Mailing Address:
P.O. Box 4240
Anaheim, California 92803

Visit our Website:
www.taylor-dunn.com