

**The Best Way
To Go
About Your
Business**

TAYLOR-DUNAWAY®

Revision: I



BT 2-48



BT 2-80

Shown with optional equipment installed



EQUIPPED WITH GT-DRIVE SYSTEM

Models Included:

B0-248-36 (B 2-48, 36-volt)

B0-248-48 (B 2-48, 48-volt)

B0-254-36 (B 2-54)

BT-248-36 (36-volt Back to Back Tram)

BT-248-48 (48-volt Back to Back Tram)

BT-280-36 (36-volt 10-passenger Tram)

BT-280-48 (48-volt 10-passenger Tram)

MANUAL MB-248-10

*Operation, Troubleshooting and
Replacement Parts Manual*

B 2-48/B 2-54 Serial number Starting: 146189

BT 2-48 Serial number Starting: 150719

BT 2-80 Serial number Starting: 159916

All models - Serial Number Ending 177126

COPYRIGHT NOTICE

Copyright © 2001 by Taylor-Dunn® Mfg. All rights reserved.

No part of this work may be reproduced or transmitted in any form or by any means, electronic or mechanical, including photocopying and recording, or any information storage or retrieval system without prior written permission of Taylor-Dunn® Mfg. unless such copying is expressly permitted by federal copyright law. Address inquiries to Reference Permissions, Taylor-Dunn® Mfg., 2114 W. Ball Road, Anaheim, CA 92804



TAYLOR-DUNN SERVICE CENTER

For more information about this and other Taylor-Dunn® manuals, please write Taylor-Dunn®:

**Taylor-Dunn® Mfg.
2114 W. Ball Road
Anaheim, CA 92804
(Attn: Technical Writer)**



A small sample of the many types of vehicles offered by Taylor-Dunn®



B 2-48-36 Equipped with optional hydraulic dump bed



B 1-00 Personnel carrier



BT 2-80 Eight passenger tram



MX 1600 Equipped with optional ladder rack and weld tanks



C 4-25 Husky tow tractor



CONTENTS

Introduction		Charging your vehicle	20
About this manual	2	Signet® Charger Operation, Model HB Series	20
Who Should Read This Manual	3	Signet® Charger Operation, Model HBS series	20
Responsibilities	3	Lestronic II® Charger Operation	21
How To Use This Manual	4	New Battery Break in	21
Conventions	5	Charging Time	21
How to Identify Your Vehicle	6	Storing / Returning to Service	21
BT 2-48	8	Storing Your Vehicle	21
BT 2-80	8	Returning to Service	21
Taking Delivery of Your Vehicle	9	Periodic Maintenance Checklist	22
Safety Rules and Operating Instructions		Standard Periodic Maintenance Schedule	
Standard Specifications		for the Smart View Display	23
(Common)	2	Daily Visual inspection:	24
Standard Specifications		Maintenance Guidelines for	
(Model B 2-48/2-54)	3	Severe Duty Applications	24
Standard Specifications		General Maintenance	
(Model BT 2-48)	4	Maintenance Guidelines	2
Standard Specifications		Troubleshooting Guide	3
(Model BT 2-80)	5	Lubrication Chart	4
Safety Rules and Guidelines	6	Front Axle Service	
Driver Training Program	6	Inspect the Front Wheel Bearings and	
Driver Qualifications	6	King Pin	2
Vehicle Controls	7	Adjust Front Wheel Bearings	3
Hi-Low Switch (optional)	7	Front Axle Removal and Installation	4
Key-Switch	7	Removal	4
Forward-Off-Reverse Switch	7	Installation	5
Horn Switch	7	Front Axle Disassembly	6
Accelerator Pedal	8	Replace Front Wheel Bearings	7
Foot Brake Pedal	8	Replace the King Pins and Bushings	9
Headlight Switch	8	Replace the Steering Knuckle	11
Accessory Switch (Optional)	8	Steering Component Service	
Directional Signals (Optional)	9	Front End Alignment	2
Seat Interlock Switch	9	Inspect Ball Joints	6
Steering	9	Inspect Rod Ends	7
Hazard Light Switch (Optional)	9	Adjust the Steering Gear	8
Charger Interlock	10	Replace the Steering Shaft	10
Electrolyte Alarm (Optional)	10	Replace the Steering Wheel	12
Park Brake	10	Replace the Steering Gear	13
Trailer Brake Module (optional)	11	Replace the Ball Joints, Tie Rods, and	
Smart View Display	12	Drag Link	14
Fault Code Tables	14	Replacing the Drag Link	16
Vehicle Operation Guidelines	15	Replacing the Tie Rod	17
Safety Guidelines	15	Center the Steering Gear	18
Starting:	15	Pitman Shaft Alignment	18
While driving:	15	Repair the Steering Gear	19
Loading and Unloading	15	Exploded View of Steering Gear	22
Towing Loads:	15		
Parking	16		
Automatic Electric Park Brake	16		
Towing This Vehicle	16		
Optional Dump Bed Operation	17		
Optional Hydraulic Pump Parts	19		





Table of Contents

Brake Service

- Inspect the Service Brake** 2
 - Disc Brake Pads 2
 - Disc Brake Rotor 3
- Inspect the Parking brake** 4
 - Wheel Park Brake (hydraulic disc) 4
 - Electric Motor Brake 5
- Adjust the Service Brakes** 6
 - Two or Four Wheel Hydraulic Disc Brakes 6
- Adjust the Parking Brake** 7
 - Wheel Park Brake (hydraulic disc) 7
- Check Master Cylinder Fluid** 8
- Bleed the Brake System** 9
- Flush the Brake System** 11
- Replace the Parking Brake Lining (electric motor brake)** 12
 - Inspection: 14
- Replace Front Disc Brake Pads** 15
- Replace Rear Brake Pads** 17
 - Hydraulic Disc 17
- Replace the Wheel Cylinder** 19
 - Disc Brake Body Assembly (front or rear) 19
- Repair the Brake Body** 21
- Replace the Master Cylinder** 23
- Repair the Master Cylinder** 25

Motor Service

- Inspecting the Motor Brushes** 2
 - Motors with internal cooling fans 2
- Motor Removal and Installation** 3
- Motor Inspection** 3
- Replacing the Brushes or Armature Bearing** 7
- Repairing the Commutator** 8
- Service Limits** 10
- Check Oil Level** 2
- Change Oil** 3
- Motor Removal and Installation** 4
- Rear Hub or Rotor** 5
- Removing and Installing the Rear Axles (Disc Brakes)** 6
- Transmission Assembly** 8
 - Remove and Install 8
- Disassembly and Reassembly of the Primary Reduction Gear Case** 9
- Disassembling the 3rd Member** 12
- Assembling the 3rd Member** 15
 - Pinion Bearing Preload 18
- Pinion Gear Shimming Instructions** 19
 - Setting the Pinion Gear Depth 19

Suspension

- Replace the Rear Springs** 2
- Replace the Front Springs** 3
- Replace the Spring Bushings** 4
- Replace the Shocks** 5

Tires and Wheels

- Tire Inflation** 2
- Tire Inspection** 2
- Replace the Tire/Wheel** 3
- Repair the Tire (pneumatic)** 4
- Replace the Tire (pneumatic)** 5

Battery Service

- Cleaning** 2
- Testing** 3
- Watering** 5
- Charging** 6
- Replacing (6-volt batteries only)** 7
 - Moist Charge Batteries 9
- Storage and Returning to Service** 10
 - Storage 10
 - Returning to Service 11

Sevcon Control System Troubleshooting

- Test Equipment Required: 2
- Definitions: 2
- Terminology used: 2
- Important Notes and Instructions 2
- Identifying Your Controller 3
- Start Troubleshooting Here 4
- Test 8. Anti-Rolloff Fault 17
- Test 9. Electric Motor Brake 18
- Logic Voltage Reference Table 20
- Status LED Code Table 21
- Smart View Fault Codes 22

Lestronic II® Charger Troubleshooting

- Operating Instructions and Theory of Operation** 2
- Testing the Charging Cycle** 3
- Test Equipment Required for Troubleshooting** 4
 - Important Notes and Instructions 4
- Troubleshooting for Built-in Charger** 5
- Troubleshooting for Portable Charger** 8
- Testing The Timer Relay** 9
- Testing the Interlock Relay** 10



Signet® Charger Troubleshooting	
Operating Instructions and Theory of Operation	2
HB/PT and GEL Indicator Lamps	3
Testing the Charging Cycle	3
Test Equipment Required for Troubleshooting	4
Important Notes and Instructions	4
Status LED Error Code Table	5
Troubleshooting	6
 Wire Diagrams	
Complete Vehicle	2
Dash	3
Control Panel	4
Accelerator Module Detail	5
Lighting	6
Trailer Brake Module and Receptacle	7
Hydraulic Dump option	8
 Illustrated Parts	
Front Axle	2
Steering Knuckle	4
Front Brakes	6
Steering Linkage	8
Steering Column	10
Steering Gear	12
Front Suspension	14
Transmission Gear Case	16
Rear Axle	18
Transmission Differential Case	18
Rear Brakes	20
Brake linkage	22
Rear Suspension	24
Motor	26
Electric Brake and Rear Motor Mount	28
Master Cylinder	30
Brake Lines	
with dual master cylinder	32
Brake Lines	
with single master cylinder	34
Wheels and Tires	36
Instrument Panel (dash)	38
Resetting the Smart View Display	39
Speed Control Panel	40
Miscellaneous Electrical	42
Lighting	44
Lestronic® Charger (page 1)	46
Lestronic® Charger (page 2)	48
Signet® Charger	50
Batteries	52
Seat Cushions and Deck, B 2-48 and B 2-54	54
Seat Cushions BT 2-48	56
Seat Cushions BT 2-80	56
Decals	58
Cab Options	60
Door Options, Steel Cab	62
Door Options, Fiberglass Cab	64
Hydraulic Dump Body Option	66
Rear Cargo Box	68
Hitches	70
 APPENDIX A-Special Tools	
 Appendix B: Standard Hardware Suggested Torque Limits	
Hardware Identification	2
Standard Head Markings	2
Hex Bolts	2
Other Bolts	2
Hex Nuts	3
Hex Lock Nuts (stover)	3
Other Nuts	3
Suggested Torque Values (non-critical hardware)	4
Suggested Torque Values (critical hardware)	5
 Appendix C	
Brake Lining Handling Precautions	C-1

TAYLOR - DUNN

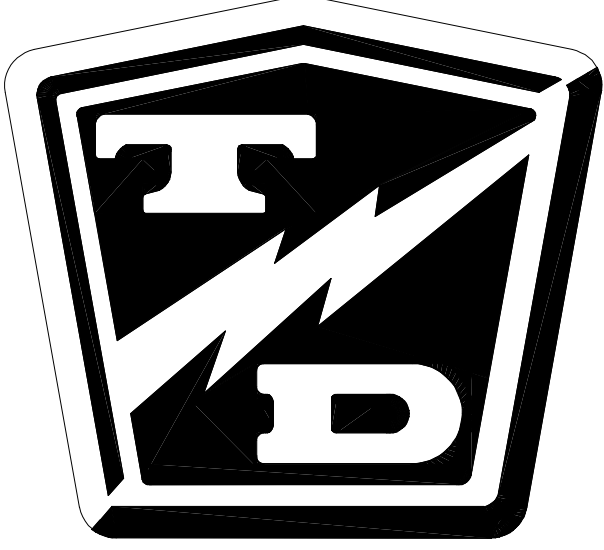

Introduction

Contents

About this manual	2
Who Should Read This Manual	3
Responsibilities	3
How To Use This Manual	4
Conventions	5
How to Identify Your Vehicle	6
Taking Delivery of Your Vehicle	8





ABOUT THIS MANUAL

The purchase of this vehicle shows a belief in high quality products manufactured in the USA. Taylor-Dunn®, a leading manufacturer of electric burden and personnel carriers since 1949, wants to be sure this vehicle provides years of reliable service. Please continue to read this manual and enjoy this high quality Taylor-Dunn® vehicle.

This manual is to serve as a guide for the service, repair, and operation of Taylor-Dunn® vehicles and is not intended as a training guide. Taylor-Dunn® has made every effort to include as much information as possible about the operation and maintenance of this vehicle.

Included in this manual are:

- Vehicle Description
- Safety Rules and Guidelines
- Operational Information
- Operator Responsibilities
- Owner Responsibilities
- Control Operation and Location Information
- Maintenance and Troubleshooting Information
- Standard Parts List

Before servicing, operating, training or performing maintenance on this or any other Taylor-Dunn® vehicle, read the appropriate Taylor-Dunn® manual.

Each Taylor-Dunn® manual references the applicable models and serial numbers on the front cover.

Please, be aware of all cautions, warnings, instructions, and notes contained in this manual.



WHO SHOULD READ THIS MANUAL

This manual is intended for use by anyone who is going to operate, own, perform maintenance on, service, or order parts for this Taylor-Dunn® vehicle. Each person should be familiar with the parts of this manual that apply to their use of this vehicle.



RESPONSIBILITIES

Of the Owner...

The owner of this or any Taylor-Dunn® vehicle is responsible for the overall maintenance and repairs of the vehicle, as well as the training of operators. Owners should keep a record of conducted training and maintenance performed on the vehicle. (OSHA Regulation, 29 CFR 1910.178 Powered Industrial Truck Operator Training).

Of the Operator...

The operator is responsible for the safe operation of the vehicle, preoperational and operational checks on the vehicle, and the reporting of any problems to service and repair personnel.

Of the Service Personnel...

The service personnel are responsible for the service and maintenance of the vehicle. At no time should a service person allow any untrained personnel to service or repair this or any Taylor-Dunn® vehicle. For the purposes of training, a qualified service person may oversee the repairs or services being made to a vehicle by an individual in training. At no time should an untrained individual be allowed to service or repair a vehicle without supervision. This manual is not a training guide.

Of the Passengers ...

The passengers are responsible to remain fully seated, keeping their hands, arms, and legs inside the vehicle at all times. Each passenger should be fully aware of the vehicle's operation. All forms of recklessness are to be avoided. Do not engage in horseplay.



HOW TO USE THIS MANUAL

This manual is organized into five main sections:

INTRODUCTION

This section describes how to use this service manual and how to identify your vehicle.

Safety Rules and Operating Instructions

This section outlines the safety and operational issues, location and operation of controls, and the operational checks that are to be performed on this vehicle. It also includes various subjects that should be included in the operator and service training program.

Maintenance Service and Repair

This section gives specific information on the servicing of the vehicle and a schedule for maintenance checks.

Electrical and Charger Troubleshooting

This section identifies the troubleshooting procedures for testing the electrical system and battery charger.

Illustrated Parts

This section provides an illustrated view of various assemblies. The illustrations are accompanied by tables identifying the parts.

Conventions

Symbols and/or words that are used to define warnings, cautions, instructions, or notes found throughout this manual:

 WARNING

or,

 WARNING

A shaded box with the word "Warning" on its left denotes a warning. A warning alerts the reader of a hazard that may result in injury to themselves or others. Be sure to follow any instructions contained within a warning and exercise extreme care while performing the task.

 CAUTION

The symbol at the left and the bold text contained within a box denotes a "Caution" and is used to inform the reader that property damage may occur. Be sure to exercise special care and follow any instructions contained with in a caution.

NOTE: Alerts the reader to additional information about a subject.

HOW TO IDENTIFY YOUR VEHICLE

This manual applies to vehicles with the same model and serial numbers listed on the front cover.

These vehicles are designed for driving on smooth surfaces in and around facilities such as industrial plants, nurseries, institutions, motels, mobile home parks, and resorts. They are not to be driven on public highways.

This vehicle conforms to requirements for Type E vehicles as described in O.S.H.A. Standard Section 1910.178 (Powered Industrial Trucks) and with all applicable portions of the American National Standard for Personnel and Burden Carriers (ANSI B56.8).

⚠ WARNING

These vehicles are not designed to be driven on public roads or highways. They are available in maximum designed speeds ranging from 6 to 16 mph. Do not exceed the maximum designed speed. Exceeding the maximum designed speed may result in steering difficulty, motor damage, and/or loss of control. Do not exceed locally imposed speed limits. Do not tow at more than 5 mph.

The locations of the model and serial numbers are illustrated as follows:

Starting early in 2007, the data plate and serial number frame stamp is in the same location for all four models covered in this manual (refer to the illustrations below). For older vehicles, the location of the data plate and frame stamp is illustrated on the following pages.



Typical BT 2-48 shown with optional equipment



Typical B 2-48 or B 2-54



Typical BT 2-80 shown with optional equipment

Vehicles manufactured before 2007 and up to March, 2007

B 2-48 and B 2-54



Under deck on deck rail

BT 2-48

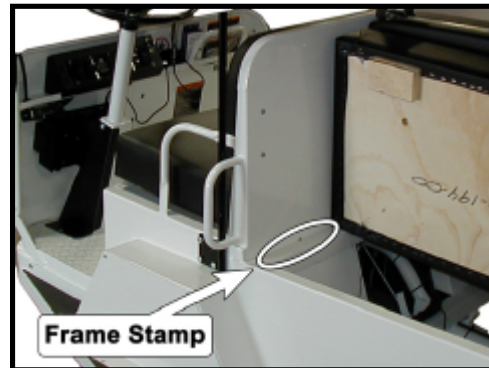

Under front left passenger cushion

BT 2-80

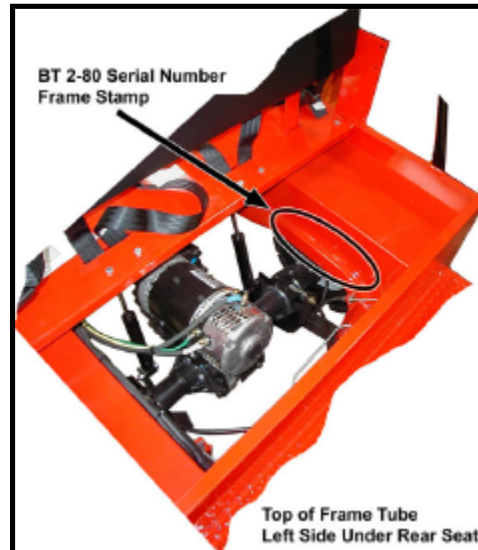



TAKING DELIVERY OF YOUR VEHICLE

Inspect the vehicle immediately after delivery. Use the following guidelines to help identify any obvious problems:

- Examine the contents of all packages and accessories that may have come in separate packages with the vehicle.
- Make sure everything listed on the packing slip is there.
- Check that all wire connections, battery cables, and other electrical connections are secure.
- Check battery cells to be sure they are filled.
- Check the tire pressure, tightness of lug nuts, and for any signs of damage.

Check the operation of each of the following controls:

- Accelerator
- Brake
- Parking Brake
- Key-Switch
- Forward/Reverse Switch
- Reverse Beeper (if equipped)
- Front Headlight Switch
- Steering Wheel
- Horn



What To Do If a Problem is Found

If there is a problem or damage as a result of shipping, note the damage or problem on the bill of lading and file a claim with the freight carrier. The claim must be filed within 48 hours of receiving the vehicle and its accessories. Also, notify your Taylor-Dunn® dealer of the claim.

If there is a problem with the operation of the vehicle, **DO NOT OPERATE THE VEHICLE**. Immediately contact your local Taylor-Dunn® distributor and report the problem. The report must be made within 24 hours of receiving the vehicle and its accessories.

The only personnel authorized to repair, modify, or adjust any part of this or any Taylor-Dunn® vehicle is a factory authorized service technician.

⚠ WARNING

The only personnel authorized to repair, modify, or adjust any part of this or any Taylor-Dunn® vehicle is a factory authorized service technician. Repairs made by unauthorized personnel may result in damage to the vehicles systems which could lead to an unsafe condition resulting in severe bodily injury and/or property damage. Unauthorized repairs may also void the vehicles warranty.

TABLE OF CONTENTS

Standard Specifications* (Common) ..	2
Standard Specifications* (Model B 2-48/2-54)	3
Standard Specifications* (Model BT 2-48)	4
Standard Specifications* (Model BT 2-80)	5
Safety Rules and Guidelines	6
Driver Training Program	6
Driver Qualifications	6
Vehicle Controls	7
Hi-Low Switch (optional)	7
Key-Switch	7
Forward-Off-Reverse Switch	7
Horn Switch	7
Accelerator Pedal	8
Foot Brake Pedal	8
Headlight Switch	8
Accessory Switch (Optional)	8
Directional Signals (Optional)	9
Seat Interlock Switch	9
Steering	9
Hazard Light Switch (Optional)	9
Charger Interlock	10
Electrolyte Alarm (Optional)	10
Park Brake	10
Trailer Brake Module (optional)	11
Smart View Display	12
Fault Code Tables	14
Vehicle Operation Guidelines	15
Safety Guidelines	15
Starting:	15
While driving:	15
Loading and Unloading	15
Towing Loads:	15
Parking	16
Automatic Electric Park Brake	16
Towing This Vehicle	16
Dump Bed (optional)	17
Operation	17
Service	17
Lowering the Dump Manually	18
Lubrication	18
Hydraulic Pump Exploded View	19
Charging your vehicle	20
Signet Charger Operation, Model HB Series	20
Signet Charger Operation, Model HBS series	20
Lestronic II® Charger Operation	21
New Battery Break in	21
Charging Time	21
Storing / Returning to Service	21
Storing Your Vehicle	21
Returning to Service	21
Periodic Maintenance Checklist	22
Standard Periodic Maintenance Schedule for the Smart View Display	23
Daily Visual inspection:	24
Maintenance Guidelines for Severe Duty Applications	24

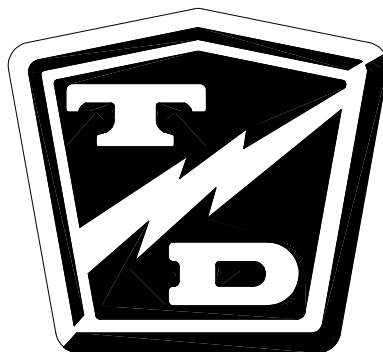

Safety Rules and Operating Instructions



SAFETY RULES AND OPERATING INSTRUCTIONS

STANDARD SPECIFICATIONS* (COMMON)

ITEM	VOLTAGE	SPECIFICATION
Min/Max Battery Weights		169 kg to 261 kg (372 lbs to 576 lbs)
Transmission		Helical Gear, Oil Bath, Automotive Type Hypoid Differential
Brakes		Rear Wheel Hydraulic Disc, Hand Operated Park Brake, or Optional 4 Wheel Hydraulic Disc, Hand Operated Park Brake
Steering		Automotive Steering 24:1
Frame		Steel Unitized Body, Heavy Duty 16 Gauge Steel, Diamond Plate
Instrumentation		Smart View Display (Battery Status Indicator, Hour Meter, System Status Monitor), Key Switch, Horn Button, Forward/Reverse Switch, Headlight Switch
Light Accessories		Headlight, Dual Tail/Brake Lights
Charger	36 Volt 48 Volt	115v AC/12A, 60Hz, 25 Amp DC, Built-In, Automatic 115v AC/15A, 60Hz, 25 Amp DC, Built-In, Automatic

These vehicles conform to requirements for Type E vehicles as described in O.S.H.A. Standard Section 1910.178 (Powered Industrial Trucks) and with all applicable portions of the American National Standard for Personnel and Burden Carriers (ANSI B56.8).

* - Specifications are subject to change without notice.



STANDARD SPECIFICATIONS* (MODEL B 2-48/2-54)

ITEM	MODEL	VOLTAGE	SPECIFICATION
Occupancy	B 2-48, B 2-54		2 Passenger
Electrical System	B 2-48	36 Volt	6-217 Amp Hour, 6 Volt, Lead Acid Batteries, Solid State Speed Control, 400 Amp
	B 2-48	48 Volt	8-250 Amp Hour, 6 Volt, Lead Acid Batteries, Solid State Speed Control, 400 Amp
	B 2-54	36 Volt	6-217 Amp Hour, 6 Volt, Lead Acid Batteries, Solid State Speed Control, 500 Amp
Dimensions	B 2-48, B 2-54		307 L X 114 W X 114 H Centimeters 121 L X 45 X 45 H Inches
Deck dimensions			104.4 W x 191 L Centimeters (41.25 W x 75.25 L Inches)
Turning Radius	B 2-48, B 2-54		350 Centimeters (138 Inches)
Tires	B 2-48		5.70 x 8 Load Range B
	B 2-54		18 x 5 x 14 Solid Extra Cushion
Dry Weight Without Batteries	B 2-48		542 kg (1194 lbs)
	B 2-54		693 kg (1528 lbs)
Maximum Load	B 2-48		1360 kg (3000 lbs)
	B 2-54		2268 kg (5000 lbs)
Motor, DC Separately Excited Field	B 2-48	36 Volt	3.2 kW, (4.4 hp) for 60 min, 5.1 kW, (6.9 hp) for 5 min
	B 2-48	48 Volt	4.4 kW, (5.9 hp) for 60 min, 7.2 kW, (9.6 hp) for 5 min
	B 2-54	36 Volt	4.5 kW, (6.0 hp) for 60 min, 8.6 kW, (11.5 hp) for 5 min

These vehicles conform to requirements for Type E vehicles as described in O.S.H.A. Standard Section 1910.178 (Powered Industrial Trucks) and with all applicable portions of the American National Standard for Personnel and Burden Carriers (ANSI B56.8).

* - Specifications are subject to change without notice.



SAFETY RULES AND OPERATING INSTRUCTIONS

STANDARD SPECIFICATIONS* (MODEL BT 2-48)

ITEM	VOLTAGE	SPECIFICATION
Occupancy		10
Electrical System	36 Volt 48 Volt	Six 217 Amp Hour, 6 Volt, Lead Acid Batteries, Solid State Speed Control, 500 Amp Eight 250 Amp Hour, 6 Volt, Lead Acid Batteries, Solid State Speed Control, 500 Amp
Dimensions		307L X 162W X 117H Centimeters 121L X 64X 46H Inches
Turning Radius		363 Centimeters (143 Inches)
Tires		5.70 x 8 Load Range B
Dry Weight Without Batteries		695 kg (1,533 lbs)
Maximum Load		1360 kg (3,000 lbs)
Motor, DC Separately Excited Field	36 Volt 48 Volt	4.5 kW, (6.0 Horse Power) for 60 min 8.6 kW, (11.5 Horse Power) for 5 min 6.0 kW, (8.0 Horse Power) for 60 min 12.2 kW, (16.3 Horse Power) for 5 min

These vehicles conform to requirements for Type E vehicles as described in O.S.H.A. Standard Section 1910.178 (Powered Industrial Trucks) and with all applicable portions of the American National Standard for Personnel and Burden Carriers (ANSI B56.8).

* - Specifications are subject to change without notice.



STANDARD SPECIFICATIONS* (MODEL BT 2-80)

ITEM	VOLTAGE	SPECIFICATION
Occupancy		Eight
Electrical System	36 Volt 48 Volt	Six 217 Amp Hour, 6 Volt, Lead Acid Batteries, Solid State Speed Control, 500 Amp Eight 250 Amp Hour, 6 Volt, Lead Acid Batteries, Solid State Speed Control, 500 Amp
Dimensions		330 L X 127 W X 112 H Centimeters 130 L X 50 X 44 H Inches
Turning Radius		406 Centimeters (160 Inches)
Tires		5.70 x 8 Load Range B
Dry Weight Without Batteries		503 kg (1,110 lbs)
Maximum Load		1,361 kg (3,000 lbs)
Motor, DC Separately Excited Field	36 Volt 48 Volt	4.5 kW, (6.0 Horse Power) for 60 min 8.6 kW, (11.5 Horse Power) for 5 min 6.0 kW, (8.0 Horse Power) for 60 min 12.2 kW, (16.3 Horse Power) for 5 min

These vehicles conform to requirements for Type E vehicles as described in O.S.H.A. Standard Section 1910.178 (Powered Industrial Trucks) and with all applicable portions of the American National Standard for Personnel and Burden Carriers (ANSI B56.8).

* - Specifications are subject to change without notice.



SAFETY RULES AND GUIDELINES

It is the responsibility of the owner of this vehicle to assure that the operator understands the various controls and operating characteristics of this vehicle (extracted from the American National Standards Institute Personnel and Burden Carriers ANSI B56.8). As well as, following the safety rules and guidelines outlined in ANSI B56.8 and listed below.

These vehicles are designed for driving on smooth surfaces in and around facilities such as industrial plants, nurseries, institutions, motels, mobile home parks, and resorts. They are not to be driven on public highways.

⚠ WARNING

These vehicles are not designed to be driven on public roads or highways. They are available in maximum designed speeds ranging from 6 to 16 mph. Do not exceed the maximum designed speed. Exceeding the maximum designed speed may result in steering difficulty, motor damage, and/or loss of control. Do not exceed locally imposed speed limits. Do not tow this vehicle at more than 5 mph.

Refer to *Vehicle Operational Guidelines, Safety Guidelines* section for important safety information regarding operating this vehicle.

⚠ WARNING

Read and follow all of the guidelines listed below. Failure to follow these guidelines may result in severe bodily injury and/or property damage.

Before working on a vehicle:

⚠ WARNING

- 1. Make sure the key-switch is in the "OFF" position, then remove the key.**
- 2. Place the forward-reverse switch in the center "OFF" position.**
- 3. Set the park brake.**
- 4. Place blocks under the front wheels to prevent vehicle movement.**
- 5. Disconnect the main positive and negative cables at the batteries.**

DRIVER TRAINING PROGRAM

According to ANSI B56.8, the owner of this vehicle shall conduct an Operator Training program for all those who will be operating this vehicle. The training program shall not be condensed for those claiming to have previous vehicle operation experience. Successful completion of the Operator Training program shall be required for all personnel who operate this vehicle.

The Operator Training program shall include the following:

- Operation of this vehicle under circumstances normally associated with your particular environment.
- Emphasis on the safety of cargo and personnel.
- All safety rules contained within this manual.
- Proper operation of all vehicle controls.
- A vehicle operation and driving test.

Driver Qualifications.

Only those who have successfully completed the Operator Training program are authorized to drive this vehicle. Operators must possess the visual, auditory, physical, and mental ability to safely operate this vehicle as specified in the American National Standards Institute Controlled Personnel and Burden Carriers ANSI B56.8.

The following are minimum requirements necessary to qualify as an operator of this vehicle:

- Demonstrate a working knowledge of each control.
- Understand all safety rules and guidelines as presented in this manual.
- Know how to properly load and unload cargo.
- Know how to properly park this vehicle.
- Recognize an improperly maintained vehicle.
- Demonstrate ability to handle this vehicle in all conditions.



VEHICLE CONTROLS

Key-Switch



A key-switch, located on the right center side of the instrument panel, turns on the vehicle. Rotate the key clockwise to turn the vehicle power on, counterclockwise to turn the vehicle power off.

The key-switch should be in the "OFF" position whenever the operator leaves the vehicle.

This switch is also designed to secure and disable the vehicle. The key can only be removed when the key-switch is in the "OFF" position.

Forward-Off-Reverse Switch



The forward-off-reverse switch, located on the right side of the instrument panel, determines the direction of travel of the vehicle. Push the top of the switch to engage the forward direction. Push the bottom of the switch to engage the reverse direction.

DO NOT SWITCH from forward to reverse or vice-versa while the vehicle is in motion. Make sure the vehicle is completely stopped before shifting.

The forward-off-reverse switch should be in the center "OFF" position, with the key-switch off and the park brake set whenever the operator leaves the vehicle.

Hi-Low Switch (optional)



The high-low switch is located on the lower left of the instrument panel. Toggle the switch lever up for normal speed. Toggle the switch lever down for slow speed.

Horn Switch



The horn switch is located on the right side of the instrument panel. Depress the switch to sound the horn, release it to turn it off.



Headlight Switch



The headlight switch is located on the top left of the instrument panel. Push the right side of the switch to turn the lights on. Push the left side of the switch to turn the light off.

Accessory Switch (Optional)



The accessory switch is located on the left side of the instrument panel and to the right of the headlight switch. Push the top of the switch to turn on the accessory. Push the bottom of switch to turn off the accessory. The accessory can be turned on with the key switch in the "OFF" position. If a vehicle is equipped with windshield wipers and one or more accessories, the windshield wipers are controlled from this switch. Other accessories are controlled from the auxiliary switch.

Accelerator Pedal



The accelerator pedal is located to the right of the brake pedal. It controls the speed of the vehicle and operates similar to the accelerator pedal in an automobile. Depress the pedal to increase speed and release the pedal to decrease speed.

Foot Brake Pedal



The foot brake pedal, is located to the right of the steering column, it is for operation with the right foot only. It works similar to the brake in an automobile. Applying pressure to the brake pedal slows the vehicle according to the amount of pressure applied. Relieving pressure from the pedal releases the braking action.



Seat Interlock Switch



A switch located under the driver's seat disables the power to the vehicle when the driver leaves the seat. The driver must be seated for the vehicle to operate.

Whenever the driver leaves the vehicle, the driver should turn the key-switch off, place the forward-off-reverse switch in the center "OFF" position, and set the park brake.

⚠ WARNING

The seat interlock switch is only one part of the vehicle safety system. The interlock switch should not be relied upon as the only safety feature used to disable or disengage this vehicle. Doing so could result in unexpected movement of the vehicle causing severe bodily injury and/or property damage.

Steering



The steering wheel and steering system are similar to an automobile. To turn right, turn the steering wheel clockwise. To turn left, turn the steering wheel counter-clockwise. If equipped with tilt steering, the release lever is located on the lower left of the steering column. Pull the lever up to reposition the steering wheel.

Directional Signals (Optional)



The turn signal lever is located on the left side of the steering column. Push the lever forward to activate the right turn signal and pull the lever back to activate the left turn signal.

Hazard Light Switch (Optional)

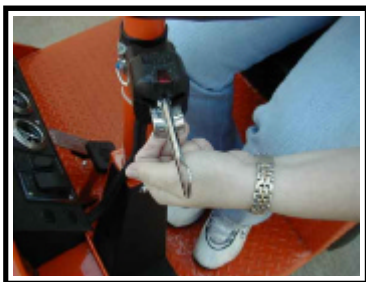

The hazard light switch is located on the left side of the steering column. The switch is a small tab. To activate the hazard lights, pull the tab out. To turn the hazard lights off, push forward or pull back the directional signal lever.



Electrolyte Alarm (Optional)

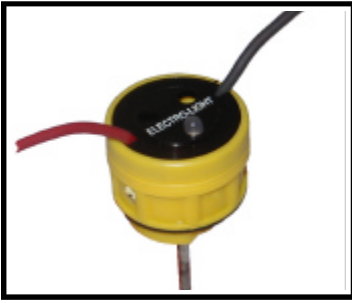

The Electrolyte Alarm is located in the battery area, in the 4th battery cell from the main battery positive cable. The Electrolyte alarm is activated when the battery cell fluid level falls below the level of the probe. The alarm is an audible continuous sound along with a bi-color indicator lamp. Inspect the fluid level in all battery cells when the alarm sounds or the bi-color lamp turns from its green color to red. The vehicle batteries should then be filled and/or charged. With the fluid level at a normal operating level and/or the batteries charged the alarm and light will reset.

Park Brake



The parking brake is actuated with a hand lever, which is located to the right of the driver. To set the parking brake, push down on the brake pedal and pull the lever up until it locks. To release the park brake, depress the foot brake pedal, pull up on the park brake handle, push the release button, and lower the handle.

Charger Interlock

The charger interlock is designed to disable the vehicle from being driven while the AC charger cord is plugged into a functioning power source.



Trailer Brake Module (optional)

The trailer brake module controls the braking functions of a trailer equipped with electric brakes. There have been many styles of brake modules used. All of the brake modules that have been used function the same other than that the location of the manual adjustment controls may vary.

The brake module will be located under the dash tray to the left of the steering column. It has a red indicator light (LED), a Thumb wheel braking force adjustor, a Pendulum level adjustment lever, and a Manual Braking lever.

As the vehicle slows during braking, the brake module sends a signal to the trailer energizing the trailer brakes. This signal is proportional depending on how fast the vehicle is stopping.



LED: The LED's brightness is related to the braking force at the trailer, dim with little or no signal to bright at maximum braking force. Once the vehicles has stopped, the LED will remain at it's dimmest intensity as long as the brake pedal is depressed.



Thumb wheel: The thumb wheel is used to adjust how much braking force is sent to the trailer brakes. Rotate the thumb wheel upward towards the top of the housing to increase the braking force.



Pendulum Lever: The brake sensor inside the module must be level for it to function correctly. The pendulum lever is used to level the internal brake sensor. Perform the following steps to adjust the sensor:

- 1 This adjustment must be done with the trailer disconnected from the vehicle.
- 2 Stop the vehicle on a level surface but do not release the brake pedal.
- 3 Adjust the thumb wheel to its minimum position downward towards the bottom of the module case.
- 4 Pull the pendulum towards the front of the module case. The LED should be at it's maximum intensity.
- 5 Slowly push the pendulum towards the rear of the module case and stop when the LED just reaches its minimum intensity. The pendulum should be very close to vertical.
- 6 Repeat the previous two steps a few times to be sure that the pendulum is at the correct position.

Manual Braking Lever: The manual braking lever can be used to manually apply the trailer brakes. Slide the lever to the left to apply the brakes. The braking force is proportional depending on how far the lever is moved.





SAFETY RULES AND OPERATING INSTRUCTIONS

Smart View Display

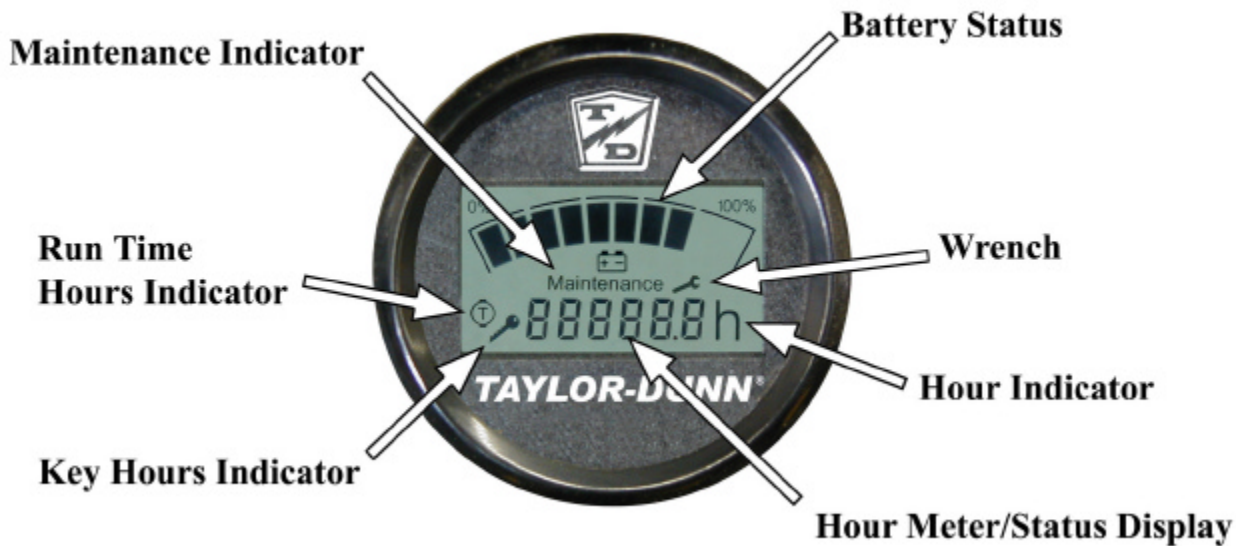

The Smart View Display (SVD) functions as a Battery Status Indicator (BSI), Hour Meter (HM), speed controller status monitor, and as an optional maintenance monitor feature. The operation of each of these functions is described below.

BSI: A bar graph representing the current state of charge is located across the top of the display. When the batteries are fully charged, all segments of the bar graph will be on. As the batteries are used, segments will turn off in the order of right to left.

When the batteries are discharged to 75%, the last three segments will flash indicating that you are approaching the end of the battery cycle. At this time, the vehicle's batteries should be charged as soon as possible.

At 90%, all segments will flash and the vehicle's speed will be reduced. At this time, the vehicle should be removed from service for charging. Discharging beyond 90% will result in damage to the batteries that will shorten the battery life-span.

NOTE: The battery status gauge as well as any faults indicating low battery voltage will not reset until the batteries have successfully completed a charging cycle.

HM: Depending on the revision level of the controller, there are one or two hour meter functions, Key Hours and Run Time Hours (see note below).

Key Hours is the accumulated length of time in hours that the key switch is in the "ON" position.

Run Time Hours is the accumulated length of time that the vehicle has been in operation. Time is accumulated when the FS-1 switch in the accelerator module is closed.

One of the Hours functions is being displayed whenever the either of the Hours Indicators are visible at the right side of the display.

NOTE: The Key Hours function was discontinued starting with revision K controllers shipped in 2007.

Key Hours: When the display is turned on, the Key Hours will be displayed for approximately 5-seconds as indicated by the Key Hours Indicator located at the lower left of the display. The icon represents the silhouette of a key.

Run Time Hours: After the initial 5-seconds, the Run Time Hours will be displayed as indicated by the Run Time Hours Indicator located at the left of the display. The icon represents a motor symbol with a "T" in the center.

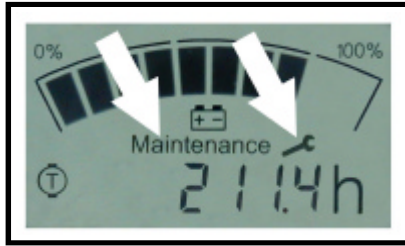

Display showing Maintenance and Wrench icons

Maintenance Monitor:

*NOTE: The Maintenance Monitor function is optional.
The Maintenance Monitor function can be turned ON or OFF by your dealer.*

Operation: The SMD notifies the operator 10-hours (standard) before a scheduled maintenance is due. During this warning period, the meter will continue to alert the operator. This should allow sufficient time for the operator to schedule the maintenance that is due, with minimal down time. If the scheduled maintenance is not performed before the warning period elapses, then the vehicles maximum speed will be significantly reduced.

Warning period: The warning starts when the Maintenance Indicator is ON and the Wrench icon is flashing. The Wrench icon will continue to flash until the warning time has expired.

Maintenance Due: Once the warning has expired and the maintenance is due, the Wrench icon will stop flashing and remain ON. Additionally, the vehicles maximum speed will be significantly reduced until the maintenance is performed and the display is reset. The display should only be reset by an authorized technician. Refer to the ***Illustrated parts*** section for information regarding tools required to reset the Smart View Display.



Speed controller status: The display will indicate a fault code whenever the control system logic detects a problem with the control system. A fault code is being displayed whenever the Fault Code Indicator (the letter 'F') is visible at the left of the numeric display. Refer to the fault code table in this section for a summary description of the fault codes.



SAFETY RULES AND OPERATING INSTRUCTIONS

Fault Code Tables

NOTE: Most faults are a result of a fault in the control system that will require service by a qualified technician. These faults are shown here for reference only.

Operator correctable faults are shown in bold and underlined.

Level 1 Faults

<u>Fault Code</u>	<u>Description</u>	<u>What to do</u>
<u>F01000</u>	<u>P/S Motor Overheated</u>	Stop the vehicle and allow the system to cool down.
F01001	Motor Brush Fault	Refer to service technician
F01002	Pump Motor Brush Fault	Refer to service technician
F01003	P/S motor Brush Fault	Refer to service technician
<u>F01004</u>	<u>Low Battery Volts</u>	Batteries are empty and require charging. If this fault does not reset after the charge cycle is complete then there may be a problem with the charger or batteries.
<u>F01005</u>	<u>Controller Overheated</u>	Refer to qualified service technician.
<u>F01006</u>	<u>Traction Motor Hot</u>	Stop the vehicle and allow the system to cool down. This could be a result of an overloaded vehicle.
<u>F01007</u>	<u>Pump Motor Overheated</u>	Stop the vehicle and allow the system to cool down. This could be a result of an overloaded vehicle.
F01008	Wiring fault	Refer to service technician

Level 4 Faults

<u>Fault Code</u>	<u>Description</u>	<u>What to do</u>
F04000	Open Contactor	Refer to service technician
F04001	Contactor Welded	Refer to service technician
F04002	Steer POT Fault	N/A
<u>F04003</u>	<u>Sequence Fault</u>	Start up switches were not operated in the correct order. Refer to <u>Vehicle Operation Guidelines</u> for correct sequence.
F04004	F&R Fault	Refer to service technician
<u>F04005</u>	<u>F&R Fault</u>	Direction was selected before start switch was closed. Place direction selector in the OFF position and restart.
<u>F04006</u>	<u>Interlock Fault</u>	Seat or foot interlock switch not closed.
<u>F04007</u>	<u>Inch Switch Fault</u>	F&R switch NOT in neutral.
F04008	Steer Fault	Refer to service technician
<u>F04009</u>	<u>Low Battery Volts</u>	Extreme low battery voltage at the controller. May be a result of severely discharged battery or wrong battery installed. Confirm that the correct battery is installed and charge the battery.
F04010	High battery Volts	Refer to service technician
F04011	Out of Range Fault	Refer to service technician
F04012	CRC Fault	Refer to service technician
F04013	Capacitor Fault	Refer to service technician

Level 5 Faults

<u>Fault Code</u>	<u>Description</u>	<u>What to do</u>
F05000	Contactor Over Current	Refer to service technician
F05001	Controller Fault	Refer to service technician
F05002	Configuration Error	Refer to service technician
F05003	Internal Fault	Refer to service technician
F05004	VA Fail	Refer to service technician
F05005	Data Layer Fault	Refer to service technician
F05006	MOSFET Short	Refer to service technician
F05007	Power Up Fault	Refer to service technician
F05008	Line Contactor Short	Refer to service technician
F05009	Wiring/Motor Short	Refer to service technician
F05010	Power Up Fault	Refer to service technician
F05011	Drive 0 ON	Refer to service technician
F05012	Drive 1 ON	Refer to service technician
F05013	Drive 0 OFF	Refer to service technician
F05014	Drive 1 OFF	Refer to service technician
F05015	Drv 0 MOSFET Trip	Refer to service technician
F05016	Drv 1 MOSFET Trip	Refer to service technician
F05017	Traction ON	Refer to service technician
F05018	Traction OFF	Refer to service technician
F05019	MOSFET Short_L	Refer to service technician
F05020	Power Up Fault	Refer to service technician
F05021	Traction Welded	Refer to service technician
F05022	Traction MOSFET	Refer to service technician
F05023	Auto Zero	Refer to service technician
F05024	Drive 0 ON L	Refer to service technician
F05025	Drive 1 ON L	Refer to service technician
F05026	Drive 0 OFF L	Refer to service technician
F05027	Drive 1 OFF L	Refer to service technician
F05028	0 MOSFET trip L	Refer to service technician
F05029	1 MOSFET trip L	Refer to service technician
F05030	Traction ON L	Refer to service technician
F05031	Traction OFF L	Refer to service technician
F05032	MOSFET Short R	Refer to service technician
F05033	Power Up Fault	Refer to service technician
F05034	Traction Welded	Refer to service technician
F05035	Traction MOSFET	Refer to service technician
F05036	Auto Zero R	Refer to service technician
F05037	Drive 0 ON R	Refer to service technician
F05038	Drive 1 On R	Refer to service technician
F05039	Drive 0 OFF R	Refer to service technician
F05040	Drive 1 OFF R	Refer to service technician
F05041	0 MOSFET Trip R	Refer to service technician
F05042	1 MOSFET Trip R	Refer to service technician
F05043	Traction ON R	Refer to service technician
F05044	Traction OFF R	Refer to service technician
F05045	Stack Corrupt	Refer to service technician
F05046	Open Contactor	Refer to service technician

Level 2 Faults

<u>Fault Code</u>	<u>Description</u>	<u>What to do</u>
<u>F02000</u>	<u>Throttle Fault</u>	Occurs if throttle control voltage is high at start up indicating that the throttle pedal was depressed when the start switch was closed. If the pedal was not depressed, then refer to qualified service technician.
F02001	Throttle Fault	
F02002	Belly Switch Fault	Refer to service technician
F02003	Open Field	Refer to service technician
F02004	Open Field L	Refer to service technician
F02005	Open Field R	Refer to service technician



VEHICLE OPERATION GUIDELINES

Safety Guidelines

- Only qualified and trained operators may drive this vehicle.
- Drive only on level surfaces or on surfaces having an incline of no more than 10% (5.6 degrees).
- Drive slowly when making a turn, especially if the ground is wet or when driving on an incline.
- This vehicle may overturn easily if turned sharply or when driven at high speeds.
- Observe all traffic regulations and speed limits.
- Keep all body parts (head, arms, legs) inside this vehicle while it is moving.
- Keep the vehicle under control at all times.
- Yield right of way to pedestrians, ambulances, fire trucks, or other vehicles in emergencies.
- Do not overtake another vehicle at intersections, blind spots, or other dangerous locations.
- Do not drive over loose objects, holes, or bumps.
- Yield right of way to pedestrians and emergency vehicles.
- Stay in your driving lane under normal conditions, maintaining a safe distance from all objects.
- Keep a clear view ahead at all times.

Starting:

Perform all necessary vehicle preparation steps, inspections, or maintenance before operating this vehicle.

NOTE: The vehicle is equipped with a seat or foot interlock switch. This switch must be closed BEFORE the throttle is depressed.

1. Make sure the forward-off-reverse switch is in the center "OFF" position.
2. If equipped with a manual park brake, set the parking brake.
3. Hold down the foot brake.
4. Rotate the ON-OFF switch to the "ON" position.
5. Wait 1-second then place the forward-off-reverse switch in the desired direction of travel.
6. Release the parking brake.
7. Release the foot brake.
8. Slowly depress the throttle pedal.

While driving:

- Slow down and sound the horn to warn pedestrians or when approaching a corner or other intersection.
- No reckless driving.
- Do not drive this vehicle on steep inclines or where prohibited.
- Immediately report any accidents or vehicle problems to a supervisor.

NOTE: This vehicle is equipped with regenerative motor braking. When the throttle pedal is released, the motor is converted into a generator. This will slow the vehicle and return this energy to the battery. To disable the motor braking action and allow the vehicle to coast, hold slight pressure on the throttle pedal.

NOTE: If the operator leaves the driver seat while in motion, the vehicle will come to an abrupt stop.

Loading and Unloading

- Do not carry more than the maximum number of passengers allowed for this vehicle.
- Do not exceed the cargo load capacity.
- Do not load cargo that can fall off.
- Be careful when handling cargo that is longer, wider, or higher than this vehicle, be sure to properly secure all loads.

Towing Loads:

- Do not exceed the towing capacity of the tractor.
- Do not exceed the load capacity of the trailer. Refer to documentation supplied with your trailer for information regarding load capacity of the trailer.
- Make sure all loads are securely tied down. Refer to documentation supplied with your trailer for information regarding attaching loads to the trailer.
- Do not back up when towing more than one trailer.
- Drive slowly when towing loads with a high center of gravity.
- When turning, be sure to allow for "corner cutting" of the trailer.
- Allow for longer stopping distances when towing heavy loads.
- Allow for longer stopping distances when driving down a grade.



SAFETY RULES AND OPERATING INSTRUCTIONS

Parking

Before leaving the vehicle:

- Set the parking brake.
- Set the forward-off-reverse switch to the "OFF" position.
- Rotate the start switch to the "OFF" position.

In addition:

- If parking this vehicle on an incline, turn the wheels to the curb, or block the wheels.
- Do not block fire aisles, emergency equipment, stairways, or exits.

Automatic Electric Park Brake

This vehicle may be equipped with an automatically applied electric parking brake. Under normal driving conditions, the parking brake will be applied when the start switch is turned off or the operator leaves the driver seat. It will also be applied if the control system loses power such as when the emergency battery disconnect switch (if equipped) is activated.

NOTE: The vehicle will come to an abrupt stop if the start switch is turned off or the operator leaves the driver seat while the vehicle is in motion.

The parking brake is powered by the vehicle battery. It will be applied whenever the batteries are disconnected. It may be applied if the batteries are severely discharged.

If the vehicle power system fails and applies the brake, the can be released by disconnecting the electric brake from the control system and connecting a 20 to 24 volt DC source (1.5A) to the electric brake.

Towing This Vehicle

To tow this vehicle, attach a tow strap to the front bumper tow-bar.

NOTE: If the vehicle is equipped with the automatic electric park brake, do not tow the vehicle with the drive wheels on the ground.

Use another driver to steer this vehicle while it is being towed. Be sure the driver uses the brakes when the towing vehicle slows or stops. Do not tow the vehicle faster than 5 m.p.h. or its maximum designed speed, whichever is lower.

If at all possible, this vehicle should be placed on a carrier, rather than towing.

⚠ WARNING

The automatic park brake should be disabled for servicing or towing procedures only. Do not operate the vehicle while the automatic park brake is disabled. Operating the vehicle with the automatic park brake disabled could lead to severe bodily injury and/or property damage.

⚠ CAUTION

This vehicle is equipped with regenerative braking. Follow these steps before towing this vehicle.

1. To tow this vehicle the start switch must be in the "OFF" position.

2. Place the forward/reverse switch in the center "OFF" position.

Failure to follow these instructions may result in damage to the vehicle.



DUMP BED (OPTIONAL)

There are numerous variations of the dump bed options that are available for the Model B series vehicles. Although the physical design of the dump bed varies, the operation is basically the same. Refer to the original vehicle sales order for specific information regarding the dump bed option used.

NOTE: The dump bed option must be installed at the factory; field kits are not available.

There are numerous variations of the dump bed options that are available for the Model B series vehicles. Although the physical design of the dump bed varies, the operation is basically the same. Refer to the original vehicle sales order for specific information regarding the dump bed option used.

NOTE: The dump bed option must be installed at the factory; field kits are not available.

⚠ WARNING

Before operating the dump bed, place the forward/reverse switch in the center (OFF) position, turn the key switch OFF and set the parking brake.

Do not operate the dump bed while parked sideways across a grade.

Do not operate the vehicle unless the dump bed is in its fully lowered position.

Failure to comply with these restrictions could result in severe bodily injury and/or property damage.

Operation

⚠ CAUTION

Before operating the dump bed, confirm that there is enough vertical clearance above the vehicle.

⚠ DANGER

Do not operate the dump bed while underneath electrical wires. Contact with electrical wires may result in serious injury or death.

The dump bed is operated hydraulically through two push button switches.

The actual location of these switches will vary depending on the type of dump bed. The switches will be located at the rear of the vehicle on the left or right side.

⚠ WARNING

Do not place any body part underneath a raised bed unless the bed prop rod is in place. Severe bodily injury will result if the bed lowers unexpectedly.

Press the top button to raise the bed. The bed should remain in the raised position when the button is released. If the bed does not hold its position, then the hydraulic system should be serviced.

Press the bottom button to lower the bed. The bed should come down within 3 to 15 seconds. If the bed does not lower, or lowers slowly then the hydraulic system should be serviced.

Service

Service should only be performed by qualified technicians familiar with hydraulic systems.

If the lowering rate of the dump bed has diminished, it may be a result of a clogged filter or plugged restricted flow fitting. The filter is internal of the pump and the pump must be disassembled to clean the filter (item # 18 on the exploded part diagram). The restricted flow fitting is installed at the cylinder, the hydraulic hose is attached to this fitting. Remove the hose and fitting to make sure nothing has plugged the hole in the fitting.

⚠ WARNING

The restricted flow fitting controls the lowering rate of the dump. Do not modify the restricted flow fitting or remove it from the system as this will result in rapid falling of the dump and may cause severe bodily injury and/or property damage.

There is an internal high pressure relief valve in the pump. This valve must be readjusted whenever the pump is disassembled. To adjust the valve:

1. Raise the dump to its fully extended position and tie or block it in place.
2. Press the lowering button to relieve back pressure.
3. Install a pressure gauge (3,000 pound) in line with the high pressure hose to the cylinder.
4. Press the raise button and read the maximum pressure on the gauge. Maximum pressure should be approximately 2,000 pounds. Adjust the relief valve as required.

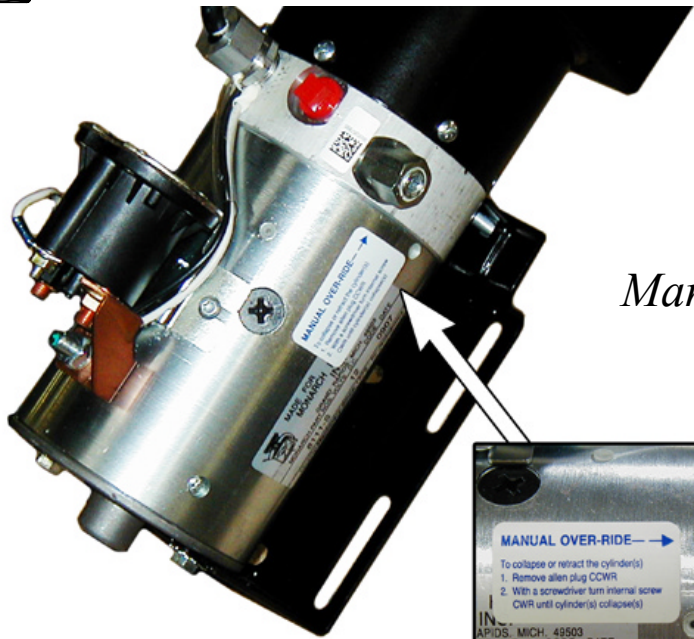

Manual Release



Lowering the Dump Manually

There is a manually operated valve located on the left side of the hydraulic pump assembly (see illustration). This valve should only be used if the dump fails to lower by pressing the lowering button. The valve is covered by an Allen screw. Remove the Allen screw to access the valve then turn the internal screw clockwise to lower the dump.

⚠ WARNING

Do not place any body part underneath a raised bed unless the bed prop rod is in place. Severe bodily injury will result if the bed lowers unexpectedly.

Lubrication

Under normal conditions, all of the pivot points should be lubricated with chassis grease every 3-months. This includes the upper and lower hydraulic cylinder pivots and the dump bed pivot points. Depending on the type of dump bed, there may be more than one grease fitting for the bed pivots. If grease fittings are not provided, then the pins must be removed to apply grease.

The hydraulic fluid level of the tank should be inspected weekly and filled as required (see illustration).

Use only use Dextron automatic transmission fluid. Using any other fluid may result in damage to the hydraulic pump. The tank must be filled only when the dump is in its fully lowered position. Fill the tank to within approximately 1-1/2 to 2-1/2 inches from the filler hole.

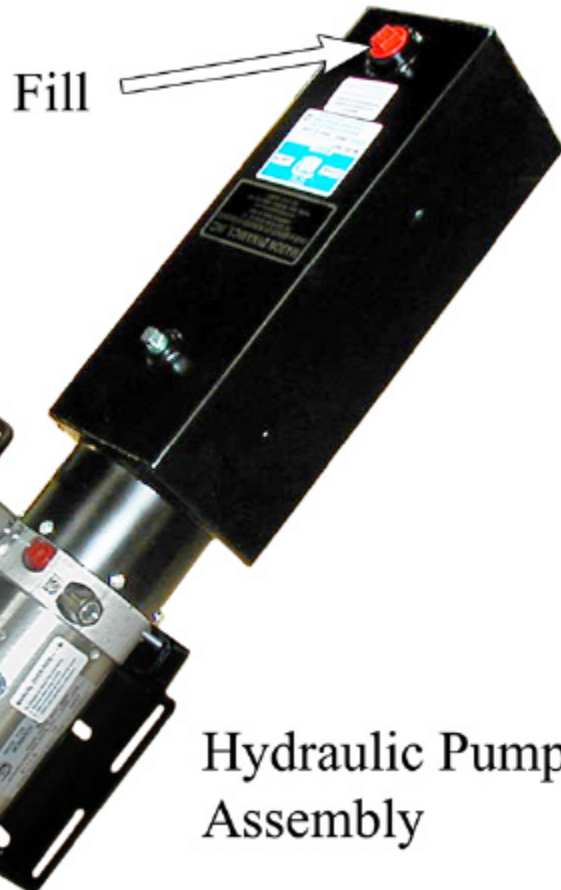

Hydraulic Pump Assembly



HYDRAULIC PUMP EXPLODED VIEW

This view is provided by the manufacturer of the pump and should only be used as a reference. Refer to the pump manufacturer's web site for current detailed information: <http://www.monarchhyd.com/>. The pump model # is M-303.

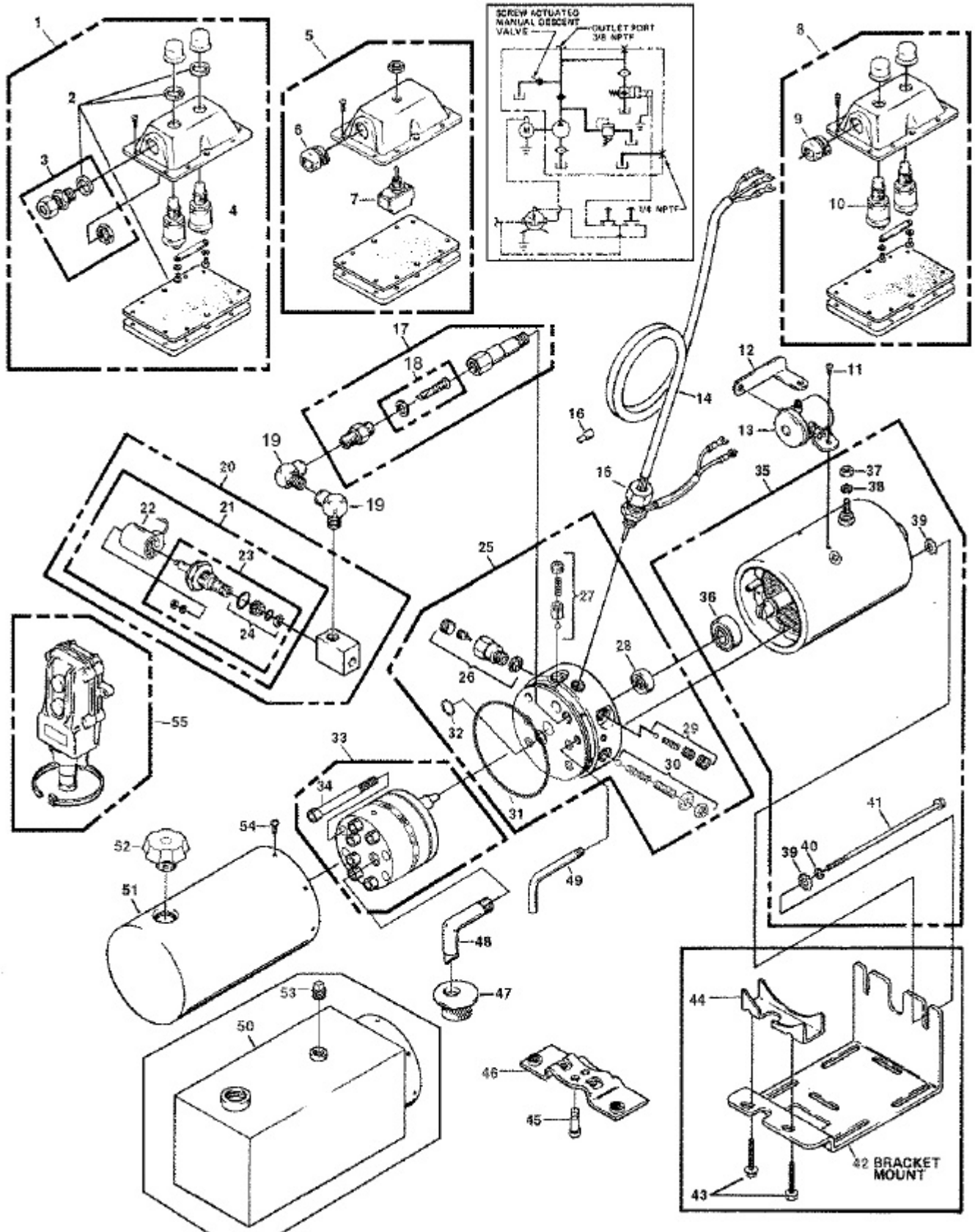



CHARGING YOUR VEHICLE

⚠ WARNING

Explosive mixtures of Hydrogen gas are present within battery cells at all times. Do not work with or charge battery in an area where open flames (including gas furnace or water heater pilots), sparks, cigarettes, or any other sources of combustion are present. Always provide ample ventilation in rooms where batteries are being charged. Failure to do so may result in severe bodily injury and/or property damage.

⚠ WARNING

Battery electrolyte is poisonous and dangerous. It contains sulfuric acid. Avoid contact with skin eyes or clothing. Wear rubber gloves and safety glasses while servicing batteries. DO NOT INGEST! This may result in severe bodily injury.

⚠ CAUTION

The key switch must be in the "OFF" position when charging the batteries. Failure to turn the key switch "OFF" may result in damage to the vehicles electrical system.

Signet Charger Operation, Model HB Series

The Signet® HB series chargers use a semi-automatic charging system. The charger will turn itself ON when the AC power cord is connected to the AC power source and turn itself OFF when the batteries are fully charged. Refer to the data plate on the charger for the voltage and type power required for the charger.



Typical Signet® Built In

There is a series of LED's on the faceplate of the charger that serve two functions:

1. Status of charge. The LED's will display an approximate percent of charge during the charging cycle. Refer to the table below.
2. Error condition. All three LED's flashing is an indication of a charging problem (charger will also be beeping). Refer to the **Charger Troubleshooting** section for information on error codes.



Charging State	LED1	LED2	LED3
0 to 50%	Blinking	OFF	OFF
50% to 75%	ON	Blinking	OFF
75% to 100%	ON	ON	Blinking
Cycle complete	ON	ON	ON

Signet Charger Operation, Model HBS series

The Signet® HBS series chargers are fully automatic. The charger will turn itself ON when the AC power cord is connected to the AC power source and turn itself OFF when the batteries are fully charged. Once the charge cycle is complete, the charger will continue to monitor the batteries. If the battery voltage drops during storage, the charger will start a new cycle to keep the batteries fully charged.



Typical Signet® HBS

NOTE: If the charger restarts during a short time period of storage, then it would be an indication of faulty batteries.

Refer to the data plate on the charger for the voltage and type power required for the charger.

There is a series of LED's on the faceplate of the charger that serve two functions:

1. Status of charge. The **STATUS** LED's will display an approximate percent of charge during the charging cycle. Refer to the table below.
2. Error condition. The **FAULT** LED flashing is an indication of a charging problem (charger may also be beeping). Refer to the **Charger Troubleshooting** section for information on error codes.

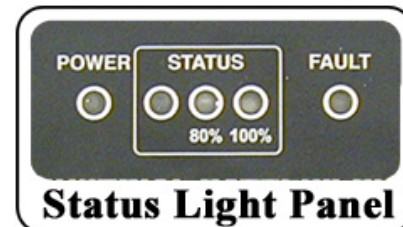



Lestronic II® Charger Operation

The Lestronic II® charger is a semi-automatic charging system. The charger will turn itself ON when the AC power cord is connected to the AC power source and turn itself OFF when the batteries are fully charged. Refer to the data plate on the charger for the voltage and type power required for the charger. When plugged in, the charger assumes that the batteries require charging and will charge for a minimum of approximately 4-hours. This charger should not be plugged in until the batteries are discharged beyond 50% or the batteries may be overcharged..

New Battery Break in

New batteries require a break in period of up to 40-cycles. The batteries will not have their full capacity during this break in period and may require longer charging times.

To obtain the maximum battery life:

Charge the batteries only after they reach a normal discharge as indicated on the Battery Status Indicator (BSI). Failure to follow this guideline could result in the batteries entering an overcharge state, which will reduce the life of the batteries. If you find it necessary to charge the batteries before they are completely discharged we recommend waiting until they are discharged a minimum of 25% to reduce the possibility of overcharging. Refer to Vehicle Controls in this section for information on how to read the BSI.

Do not discharge the batteries beyond a normal discharge as indicated on the BSI. Refer to Vehicle Controls in this section for information on how to read the BSI.

Check the battery electrolyte once a week. Do not charge the batteries if the battery electrolyte is low. Charging when the electrolyte is low will damage the batteries and shorten their life-span. Only authorized personnel should perform battery maintenance including maintaining the battery electrolyte level. Refer to Section **Maintenance, Service and Repair** for battery maintenance information.

Do not interrupt the charging cycle. When the charger is plugged in, allow it to turn off before disconnecting. Interrupting the charging cycle could lead to overcharging or discharging the batteries too deep. Both circumstances will shorten the life of the batteries.

Charging Time

Average charging time is 8 to 10-hours. The time required to fully charge your batteries will vary depending on:

- Capacity of the batteries, higher capacity requires longer charge time.
- Output of the charger, higher output requires less charge time.
- Depth of discharge, the deeper a battery is discharged, the longer it takes to charge.
- Temperature, low temperatures require longer charge time.

It is not unusual for charge times to exceed 15-hours, especially with new batteries.

Charging time is limited to 20-hours (HBS) or 18-hours (HB). A fault will occur if the charging time exceeds the 20-hour limit.

STORING / RETURNING TO SERVICE

Both storing your vehicle and returning it to service should only be performed by authorized personnel.

Storing Your Vehicle

- Clean the batteries, then fill and charge before putting the vehicle in storage. Do not store batteries in a discharged condition.
- Lube all grease fittings.
- Clean, dry, and check all exposed electrical connections.
- Inflate tires to proper pressure (if applicable).
- For extended storage, the vehicle should be elevated so that the tires do not touch the ground.

If stored for a prolonged period, the batteries should be charged as follows:

Returning to Service

- Check the battery's state of charge and charge if required.

Storage Temperature (F)	Charging Interval (months)
Over 60	1
Between 40 and 60	2
Below 40	6

- Perform ALL maintenance checks in the periodic checklist.
- Remove any blocks from the vehicle and/or place the vehicle down on to the ground.
- Test drive before putting into normal service.



PERIODIC MAINTENANCE CHECKLIST

Maintenance Item ^{2, 3}	Weekly ¹ (20hrs)	Monthly ¹ (80hrs)	Quarterly ¹ (250hrs)	Semi - Annual ¹ (500hrs)	Annually ¹ (1000hrs)
Check Condition of Tires and Tire Pressure	●				
Check All Lights, Horns, BEEPERS and Warning Devices	●				
Check and Fill Batteries	●				
Check Brake System		●			
Check Steering System		●			
Check for Fluid Leaks		●			
Lubricate Vehicle			●		
Clean and Tighten All Wire Connections			●		
Wash and Service Batteries			●		
Check Park Brake				●	
Check Motor Brushes and Blow Out Motor				●	
Check Front Wheel Bearings				●	
Check Rear Axle Oil				●	
Change Rear Axle Oil					●
Check and Tighten all Nuts and Bolts					●
Clean and Repack Front Wheel Bearings					●

1, 2, 3 - See notes on following pages.

⚠ WARNING

Only properly trained and authorized technicians should perform maintenance or repairs to this vehicle. Repairs or maintenance by improperly trained or unauthorized personnel could cause improper operation of the vehicle or premature failure of components resulting in severe bodily injury and/or property damage.



**STANDARD PERIODIC MAINTENANCE SCHEDULE
FOR THE SMART VIEW DISPLAY**

NOTE: The maintenance function is optional. Your vehicle may be equipped with a customized maintenance schedule

PREVENTATIVE MAINTENANCE SCHEDULE		
MAINTENANCE LEVEL	HOUR INTERVAL ¹	MAINTENANCE TO BE PERFORMED ^{2,3}
1	500	Inspect the brake system including the park brake and mounting hardware
		Inspect the steering system, tighten the steering shaft coupler on the steering gear input shaft
		Lubricate the vehicle, check for leaks
		Inspect safety interlocks
		Inspect front and rear wheel bearings
		Inspect and adjust fork collar bearings (3-wheel trucks only)
		Inspect and tighten all nuts and bolts. First 500 hours and then every 1000 hours.
2	1000	Inspect and tighten all nuts and bolts
		Clean and repack front wheel bearings
		Inspect and tighten all wire connections
		Inspect the motor brushes and commutator
		Inspect the king pin bushings
		Check front end alignment
3	2000	Change oil in the drive and rear axle
		Flush hydraulic brake system
		Inspect suspension bushings
		Replace brake pedal/treadle return spring
		Inspect frame for damage

1, 2, 3 - See notes on following pages.



SAFETY RULES AND OPERATING INSTRUCTIONS

Daily Visual inspection:

Tire condition and pressure.

External frame damage (body).

Operation of all lights and warning alarms and/or horns.

Smooth and proper operation of all controls such as but not limited to:

- Accelerator pedal, Brake pedal, Steering, Parking brake, etc.
- Proper operation of all locking devices such as but not limited to:
- Tool box, Removable battery trays, Cargo box, Cab doors, etc.
- Proper operation of all interlocking switches such as but not limited to:
- Key switch, Seat interlock switch, Charger interlock switch, etc.

Inspect for leaking fluids or grease.

MAINTENANCE GUIDELINES FOR SEVERE DUTY APPLICATIONS

1. This maintenance checklist is based on the average application. If the vehicle is operated under “severe conditions”, service procedures should be conducted more frequently than specified. The frequency of service under severe conditions is determined by the use of the vehicle. The owner/operator must evaluate the operating environment to determine the increase in maintenance frequency.

In addition, the whole vehicle should be inspected monthly for signs of damage. The damage must be repaired immediately.

The following list is meant as a guide and is not all-inclusive of a “severe duty” application.

- Extreme temperature.
 - Bumpy, dusty, or ill maintained roads.
 - Excessively wet areas.
 - Corrosive or contaminated areas.
 - Frequent loading of vehicle at/near capacity.
 - Use on multiple shifts.
2. Any deficiencies found during an inspection should corrected before the vehicle is returned to service.
 3. Battery water level should be inspected on a weekly schedule.



General Maintenance

TABLE OF CONTENTS

Maintenance Guidelines	2
Troubleshooting Guide	3
Lubrication Chart	4

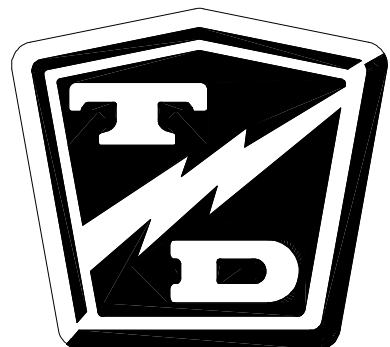



MAINTENANCE GUIDELINES

⚠ WARNING

Periodic maintenance and service must be performed on this vehicle. Failure to complete these scheduled maintenance and service procedures can result in severe bodily injury and/or property damage. It is the owner and/or operators responsibility to insure that proper service and maintenance is performed on the vehicle, described in this manual.

⚠ WARNING

Before starting any repairs:

1. Make sure the key-switch is in the “OFF” position, then remove the key.
2. Place the forward-reverse switch in the center “OFF” position.
3. Set the park brake.
4. Place blocks under the front wheels to prevent vehicle movement.
5. Disconnect the main positive and negative cables at the batteries.

⚠ WARNING

Read and follow all of the guidelines listed below. Failure to follow these guidelines may result in severe bodily injury and/or property damage.

- Avoid fire hazards and have fire protection equipment present in the work area. Conduct vehicle performance checks in an authorized area where safe clearance exists.
- Before starting the vehicle, follow the recommended safety procedures in Section 2, “Safety Rules and Operational Information.”
- Ventilate the work area properly.
- Regularly inspect and maintain in a safe working condition, brakes, steering mechanisms, speed and directional control mechanisms, warning devices, lights, governors, guards, and safety devices.
- Inspect and maintain battery limit switches, protective devices, electrical conductors, and connections in conformance with Taylor-Dunn’s® recommended procedures.
- Keep the vehicle in clean condition to minimize fire hazards and facilitate detection of loose or defective parts.
- Do not use an open flame to check level or leakage of battery electrolyte.
- Do not use open pans of fuel or flammable fluids for cleaning parts.
- Only properly trained and authorized technicians should perform maintenance or repairs to this vehicle.

TROUBLESHOOTING GUIDE

Symptom	Probable Cause
Steering Pulls in One Direction	Front End Out of Alignment
	Low Tire Pressure
Hard Steering	Dry Lube Points in Steering Linkage
	Damaged King Pin/Ball Joint
	Low Tire Pressure
Excessive Steering Play	Worn Ball Joints
	Mis-Adjusted or Worn Steering Gear
	Loose Steering Linkage
Lack of Power or Slow Operation	Brakes or Parking Brakes Dragging
	Worn Drive Gears
	Front End Out of Alignment
	Speed Control System Fault
	Speed Control System Overheated
	High/Low Speed Switch in Low or wiring to the Switch is Faulty
	Low Speed Cutback Due to Maintenance Meter Trip (optional)
Abnormal Noise	Worn Drive Gears or Bearings
	Worn Front /Rear Axle Bearings
	Loose Lug Nuts
	Motor Bearings Worn
Oil Leak in Rear Bearing Area	Rear Wheel Bearing and/or Gasket Failed
	Drive Over Filled
Brake Pedal Soft or Spongy	Air in Brake Lines
Brake Pedal Low	Brake Worn (1/16" Wear Limit)
	Brake Fluid Low
	Brakes Out of Adjustment
Braking Power Low	Brake Worn (1/16" Wear Limit)
	Brake Pads Contaminated with Fluid
	Brake Pedal Linkage Binding
	Brakes Out of Adjustment
	Air in Brake Lines
	Trailer Brake System Faulty (optional)



LUBRICATION CHART

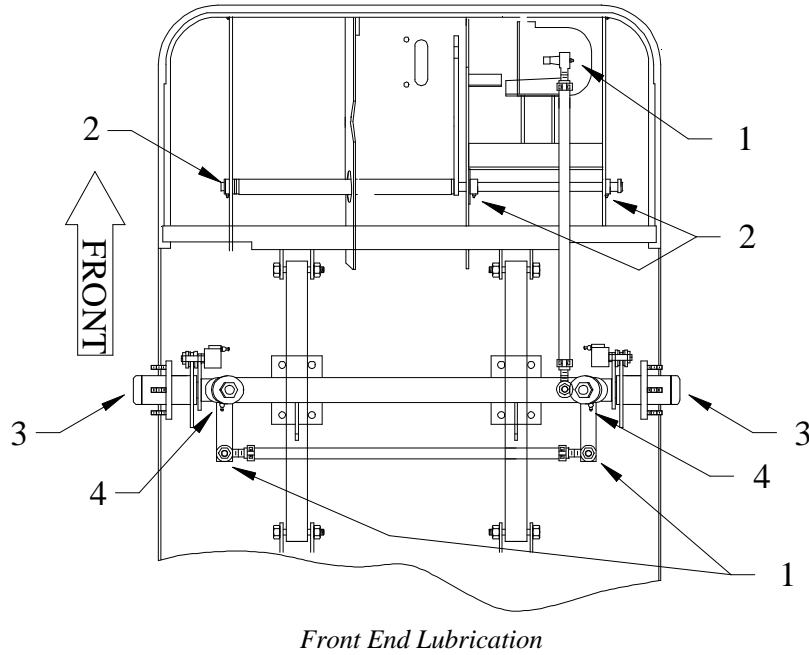

Rear Axle Lubrication

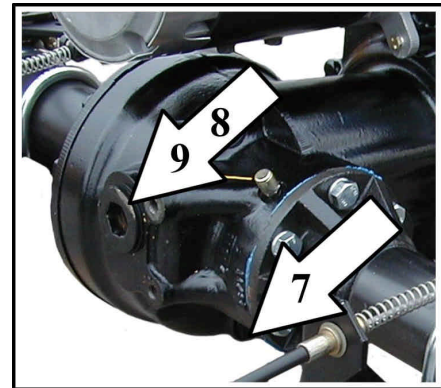

#	Description	Locations	Lubricant Type
1	Ball Joints	4	General Purpose Grease
2	Pedal Linkages	3	General Purpose Grease
3	Front Wheel Bearings	2	High Temperature Wheel Bearing Grease
4	King Pin	2	General Purpose Grease
7	Drive Drain Plug	1	
8	Drive Level Plug	1	
9	Drive Fill Plug	1	SAE 80W90 Gear Oil

Front Axle Service

TABLE OF CONTENTS

Inspect the Front Wheel Bearings and King Pin	2
Adjust Front Wheel Bearings	3
Front Axle Removal and Installation	4
Removal	4
Installation	5
Front Axle Disassembly	6
Replace Front Wheel Bearings	7
Replace the King Pins and Bushings	9
Replace the Steering Knuckle	11

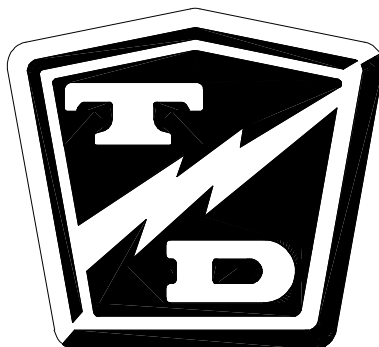



INSPECT THE FRONT WHEEL BEARINGS AND KING PIN

⚠ WARNING

1. Make sure the key-switch is in the "OFF" position, then remove the key.
2. Place the forward-reverse switch in the center "OFF" position.
3. Set the park brake.
4. Place blocks under the rear wheels to prevent vehicle movement.
5. Disconnect the main positive and negative cables at the batteries.

6. Raise the front of the vehicle and support with jack stands.

⚠ WARNING

Always use a lifting strap, hoist, and jack stands, of adequate capacity to lift and support the vehicle. Failure to use lifting and support devices of rated load capacity may result in severe bodily injury.

7. Grab the top and bottom of the tire/wheel assembly. Feel for any movement or play while pulling and pushing on the top and bottom of the tire. Any movement or play is an indication of loose wheel bearings or king pin.

*NOTE: Refer to the **Adjust Front Wheel Bearings** section for information regarding the adjustment of the wheel bearings.*

*NOTE: If the king pin is loose, then refer to **Replace the King Pins and Bushings** for information regarding replacing the king pin bushings. There are no adjustments for the king pin or bushings.*



8. Spin the wheel and listen for any grinding noise. Any grinding noise may be an indication of worn or damaged wheel bearings.

*NOTE: Refer to the **Replace Front Wheel Bearings** section for information regarding the replacement of the wheel bearings.*

9. Lower the vehicle.
10. Reconnect the main positive and negative cables at the batteries.
11. Remove the blocks from behind the wheels.
12. Release the park brake and test drive the vehicle.

ADJUST FRONT WHEEL BEARINGS

WARNING

1. Make sure the key-switch is in the "OFF" position, then remove the key.
2. Place the forward-reverse switch in the center "OFF" position.
3. Set the park brake.
4. Place blocks under the rear wheels to prevent vehicle movement.
5. Disconnect the main positive and negative cables at the batteries.

6. Raise the front of the vehicle and support with jack stands.

WARNING

Always use a lifting strap, hoist, and jack stands, of adequate capacity to lift and support the vehicle. Failure to use lifting and support devices of rated load capacity may result in severe bodily injury.

7. Remove the hub dust cap and cotter pin.
8. While rotating the hub, tighten the spindle nut to 30 ft-lbs. This seats the bearings.
9. Back off the spindle nut one flat until the hub turns, but is not loose.
10. Spin the wheel and listen for any grinding noise. Any grinding noise may be an indication of worn or damaged wheel bearings.

*NOTE: Refer to the **Replace Front Wheel Bearings** section for information regarding the replacement of the wheel bearings.*

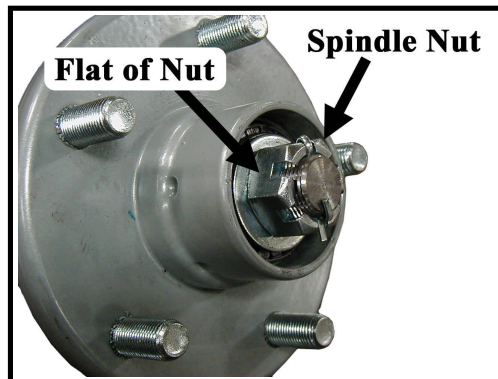

Hub with Dust Cap Removed

11. Install a new cotter pin.
12. Install the dust cap.
13. Lower the vehicle.
14. Reconnect the main positive and negative cables at the batteries.
15. Remove the blocks from behind the wheels.
16. Release the park brake and test drive the vehicle.





FRONT AXLE REMOVAL AND INSTALLATION

Removal

⚠ WARNING

1. Make sure the key-switch is in the "OFF" position, then remove the key.
2. Place the forward-reverse switch in the center "OFF" position.
3. Set the park brake.
4. Place blocks under the rear wheels to prevent vehicle movement.
5. Disconnect the main positive and negative cables at the batteries.

6. Raise the front of the vehicle and support with jack stands.

⚠ WARNING

Always use a lifting strap, hoist, and jack stands, of adequate capacity to lift and support the vehicle. Failure to use lifting and support devices of rated load capacity may result in severe bodily injury.

7. Remove both front wheels. Refer to *Tires and Wheels* section for information regarding removing the front wheels.
8. Tie up or support the front axle so it can not fall out of the vehicle.
9. Disconnect the drag link ball joint or rod end from the steering knuckle or the steering gear pitman arm.

*NOTE: Refer to the **Replacing the Ball Joints** section for information regarding the removal of the ball joints or rod ends.*

10. If equipped with front brakes, disconnect the hydraulic brake lines from the brake bodies.
11. Disconnect the front axle beam from the front springs and remove the axle from the vehicle.

*NOTE: In some configurations the front springs and or shocks will have to be removed in order to remove the axle beam. Refer to section **Front Suspension** for information regarding removing the springs and shocks.*

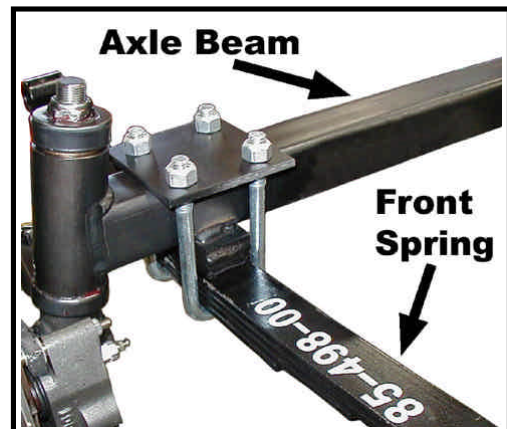

Installation

⚠ WARNING

1. Make sure the key-switch is in the "OFF" position, then remove the key.
2. Place the forward-reverse switch in the center "OFF" position.
3. Set the park brake.
4. Place blocks under the rear wheels to prevent vehicle movement.
5. Disconnect the main positive and negative cables at the batteries.

6. Raise the front of the vehicle and support with jack stands.

⚠ WARNING

Always use a lifting strap, hoist, and jack stands, of adequate capacity to lift and support the vehicle. Failure to use lifting and support devices of rated load capacity may result in severe bodily injury.

7. Install the front axle in reverse order of removal.

NOTE: Use all new cotter pins.

*NOTE: Refer to the **Replacing the Ball Joints** section for information regarding the installing the ball joints or rod ends.*

*NOTE: Refer to **Tires and Wheels** section for information regarding removing the front wheels.*

8. Realign the front wheels. Refer to **Steering Component Service** section for information regarding realigning the front wheels.
9. If equipped with front brakes, bleed the brakes. Refer to **Brake Service** section for information regarding bleeding the brakes.
10. Lower the vehicle.
11. Reconnect the main positive and negative cables at the batteries.
12. Remove the blocks from behind the wheels.
13. Release the park brake and test drive the vehicle.





FRONT AXLE DISASSEMBLY

Disassembling and reassembling involves removing and replacing the left and right steering knuckles and king pin bushings. Refer to the following sections for information regarding these procedures:

Replace the Steering Knuckle

Replace the King Pins and Bushings

NOTE: The front axle does not have to be removed unless the axle beam must be replaced. Refer to **Front Axle Removal and Installation** for information regarding removing the front axle.

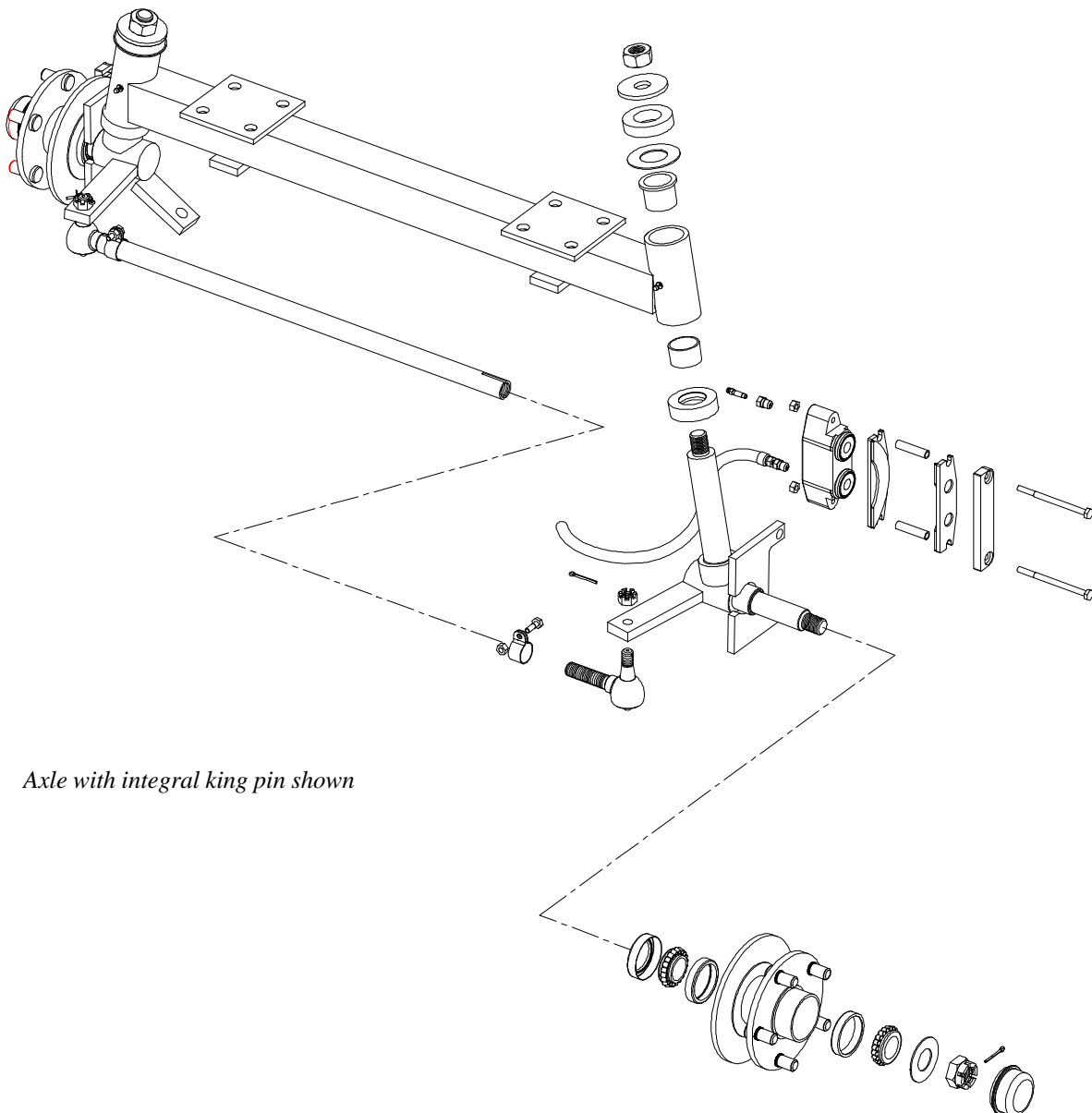

Axle with integral king pin shown

REPLACE FRONT WHEEL BEARINGS

⚠ WARNING

1. Make sure the key-switch is in the "OFF" position, then remove the key.
2. Place the forward-reverse switch in the center "OFF" position.
3. Set the park brake.
4. Place blocks under the rear wheels to prevent vehicle movement.
5. Disconnect the main positive and negative cables at the batteries.

6. Raise the front of the vehicle and support with jack stands.

⚠ WARNING

Always use a lifting strap, hoist, and jack stands, of adequate capacity to lift and support the vehicle. Failure to use lifting and support devices of rated load capacity may result in severe bodily injury.

7. Remove the tire/wheel assembly from the hub. Refer to **Replace the Steering Knuckle** for information regarding removing the steering knuckle.
8. Remove the hub dust cap, cotter pin, and spindle nut.

9. Remove the hub from the steering knuckle.

*NOTE: For a front disc brake option you must remove the brake body before removing the hub. Refer to the **Brakes** section for information regarding the removal of the brake body.*

NOTE: Catch the outer bearing as it falls out.

10. Thoroughly clean all grease from the inside of the hub and the bearings.

11. Inspect and replace the races and bearings as a set.

NOTE: It is recommended to replace all four bearings and races in the left and right wheels as a set.

12. Assemble in reverse order, using new grease seals.
 - a. Pack inner and outer bearings with grease.
 - b. While rotating the hub, tighten the spindle nut to 30 ft-lbs. This seats the bearings.
 - c. Back off the spindle nut one flat until the hub turns, but is not loose.
 - d. Install a new cotter pin.

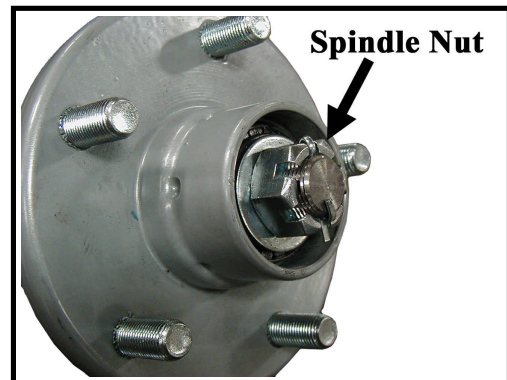

Hub with Dust Cap Removed

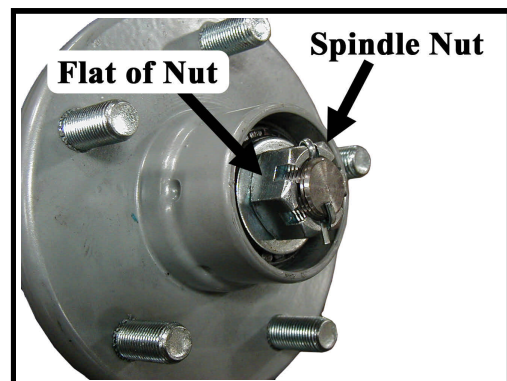

Hub with Dust Cap Removed



Maintenance, Service, and Repair

13. Install the hub dust cap.
14. Reinstall the brake body and the tire/wheel assembly.

*NOTE: Refer to the **Brakes** section for information regarding the installation of the brake body.*

15. Lower the vehicle.
16. Reconnect the main positive and negative cables at the batteries.
17. Remove the blocks from behind the wheels.
18. Release the park brake and test drive the vehicle.



REPLACE THE KING PINS AND BUSHINGS

There are different types of king pin bushings depending on the configuration of your vehicle.

- Bronze bushings in the axle beam.
- Bronze bushings in the steering knuckle.
- Metal backed teflon bushings in the axle beam or suspension arm.

NOTE: Bronze bushings must be reamed or broached to the proper diameter after they are pressed into the axle beam or steering knuckle.

WARNING

Failure to correctly broach or ream bronze bushings may result in steering difficulty and loss of control of the vehicle causing severe bodily injury and /or property damage.

Refer to the illustration below for the type of bushing in your vehicle.

WARNING

1. Make sure the key-switch is in the "OFF" position, then remove the key.
2. Place the forward-reverse switch in the center "OFF" position.
3. Set the park brake.
4. Place blocks under the rear wheels to prevent vehicle movement.
5. Disconnect the main positive and negative cables at the batteries.

6. Raise the front of the vehicle and support with jack stands.

WARNING

Always use a lifting strap, hoist, and jack stands, of adequate capacity to lift and support the vehicle. Failure to use lifting and support devices of rated load capacity may result in severe bodily injury.

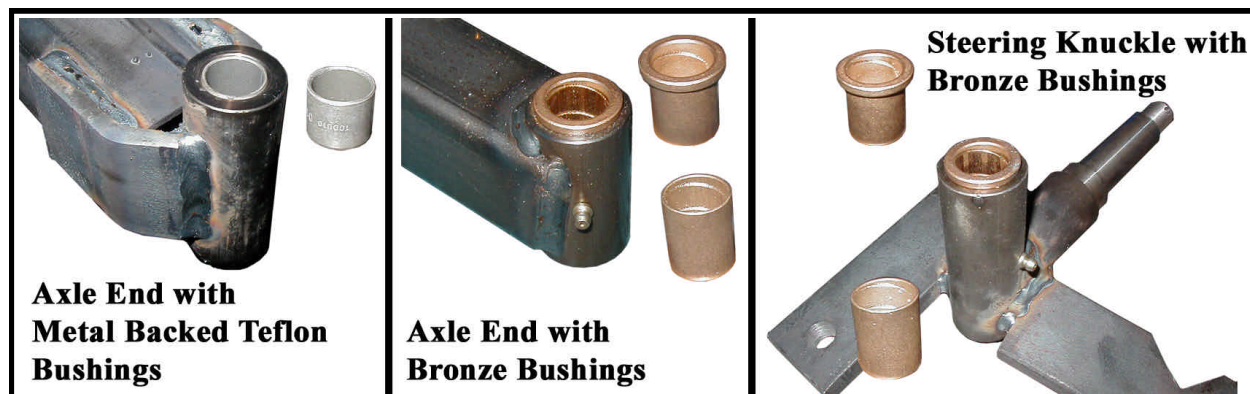

Axle End with Metal Backed Teflon Bushings

Axle End with Bronze Bushings

Steering Knuckle with Bronze Bushings



7. Remove the steering knuckle. Refer to **Replace the Steering Knuckle** for information regarding removing the steering knuckle.

NOTE: It is not necessary to remove the tie rod or drag link for this procedure.

8. Press the king pin bushings out from the axle, steering knuckle or suspension arm.
9. Press new bushings into the axle, steering knuckle or suspension arm.
 - a) **Yoke with integral king pin:** Ream or broach bronze bushings to 1.25" +/- 0.001".
 - b) **Yoke without king pin:** Ream or broach bronze bushings to 0.880" +/- 0.001".



Typical Yoke without king pin

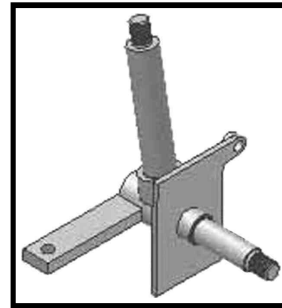

Typical yoke with integral king pin

⚠ WARNING

Failure to correctly broach or ream bronze bushings may result in steering difficulty and loss of control of the vehicle causing severe bodily injury and/or property damage.

10. Inspect the king pin for damage or wear. If any damage or wear is noted then the king pin must be replaced.
11. Reassemble in reverse order.

*NOTE: Refer to **Replace the Steering Knuckle** for information on installing the steering knuckle.*

*NOTE: It is recommended that the thrust washers or bearing be replaced whenever replacing the king pin bushings. Refer to the **Replacement Parts** section for the orientation of the bearing or washers in your vehicle.*

12. Grease the bushings (bronze only).
13. Lower the vehicle.
14. Reconnect the main positive and negative cables at the batteries.
15. Remove the blocks from behind the wheels.
16. Release the park brake and test drive the vehicle.

REPLACE THE STEERING KNUCKLE

WARNING

1. Make sure the key-switch is in the "OFF" position, then remove the key.
2. Place the forward-reverse switch in the center "OFF" position.
3. Set the park brake.
4. Place blocks under the rear wheels to prevent vehicle movement.
5. Disconnect the main positive and negative cables at the batteries.

6. Raise the front of the vehicle and support with jack stands.

WARNING

Always use a lifting strap, hoist, and jack stands, of adequate capacity to lift and support the vehicle. Failure to use lifting and support devices of rated load capacity may result in severe bodily injury.

7. Remove the tire/wheel assembly. Refer to *Tires and Wheels* section for information regarding removing the tire/wheel assembly.
8. Remove the hub bearing cap, cotter pin and nut, then remove the hub from the steering knuckle.

*NOTE: For a front disc brake option you must remove the brake body before removing the hub. Refer to the **Brakes** section for information regarding the removal of the brake body. Do not remove the hydraulic brake line from the brake body. If the brake line is removed then it will be necessary to bleed the brakes.*

NOTE: Catch the outer bearing as it falls out.

9. Remove the drag link and/or tie rod from the steering knuckle. Refer to *Replace the Ball Joints, Tie Rods, Drag Link* in this section for information regarding removal of the drag link or tie rod.
10. While supporting the knuckle, remove the king pin and thrust bearing.
11. Remove the knuckle from the axle.

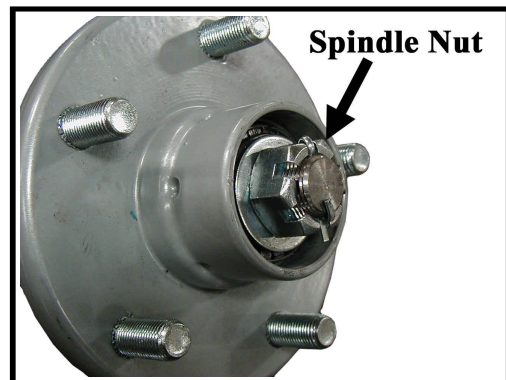

Hub with Dust Cap Removed



Maintenance, Service, and Repair

12. Thoroughly clean and/or replace all bearings, nuts, washers, and bushings.

NOTE: Both the left and right side bushings and thrust bearings should be replaced as a set.

13. Assemble in reverse order.

14. Pack the thrust bearing with grease.

15. Tighten the king pin nut as follows:

a) **Yoke with integral king pin:** Tighten the king pin nut until all of the up and down play is removed and the yoke rotates freely. The rubber washer must compress slightly to create a seal for the grease.

b) **Yoke without king pin:** tighten the king pin nut until all of the up and down play is removed and the yoke rotates freely.

*NOTE: Refer to **Replace Front Wheel Bearings** for information regarding proper tightening of the spindle nut*

16. Install new cotter pins.

17. Realign the wheels.

*NOTE: Refer to the **Steering** section for information regarding realignment of the front wheels.*

18. Lower the vehicle.

19. Reconnect the main positive and negative cables at the batteries.

20. Remove the blocks from behind the wheels.

21. Release the park brake and test drive the vehicle.



Steering Component Service

TABLE OF CONTENTS

Front End Alignment	2
Inspect Ball Joints	6
Inspect Rod Ends	7
Adjust the Steering Gear	8
Replace the Steering Shaft	10
Replace the Steering Wheel	12
Replace the Steering Gear	13
Replace the Ball Joints, Tie Rods, and Drag Link	14
Replacing the Drag Link	16
Replacing the Tie Rod	17
Center the Steering Gear	18
Pitman Shaft Alignment	18
Repair the Steering Gear	19
Exploded View of Steering Gear	22

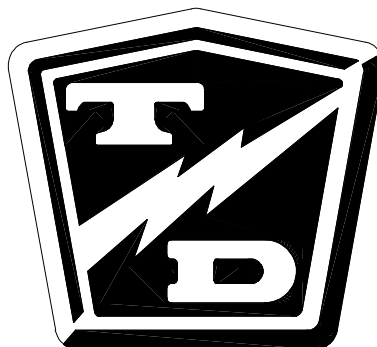



FRONT END ALIGNMENT

This section will refer to two different types of ball joints. One type is has a grease fitting and a tapered shaft where it is fitted to the steering arm or pitman arm. The second type cannot be greased and has a straight shaft. See the illustrations to the right. Depending on the configuration of your truck, it may be equipped with one or both types of ball joints.

In this text:

The first type has a grease fitting and will be referred to as a "Ball Joint."

The second type has no grease fitting and will be referred to as a "Rod End."

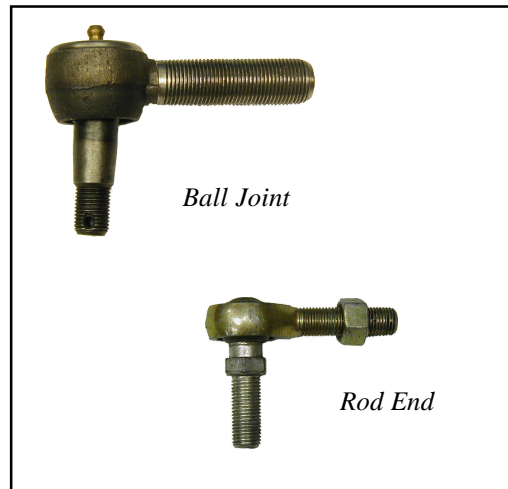

Center the Steering

⚠ WARNING

1. Make sure the key-switch is in the "OFF" position, then remove the key.
2. Place the forward-reverse switch in the center "OFF" position.
3. Set the park brake.
4. Place blocks under the rear wheels to prevent vehicle movement.
5. Disconnect the main positive and negative cables at the batteries.

6. Raise the front of the vehicle and support with jack stands.

⚠ WARNING

Always use a lifting strap, hoist, and jack stands, of adequate capacity to lift and support the vehicle. Failure to use lifting and support devices of rated load capacity may result in severe bodily injury.

7. Turn the front wheels so that they are in the straight ahead position and then tie off the wheels so that they cannot turn from the straight ahead position.
8. Disconnect the drag link from the pitman arm.

*NOTE: Refer to **Replace the Ball Joints** section for information regarding removing the ball joint or rod end from the drag link.*

9. Center the steering gear and tie off the steering wheel so that it cannot rotate.

*NOTE: Refer to **Center the Steering Gear** section for information regarding centering of the steering gear.*

- At this point both the steering wheel **and** the front wheels should be tied up and held in position. If one or the other is not tied up then you must start from the beginning.

⚠ WARNING

Do not drive the vehicle while the steering wheel or front wheels are tied in position. Driving the vehicle while the steering wheel or front wheels tied in the position may cause loss of control of the vehicle resulting in severe bodily injury and/or property damage.

- Loosen the ball joint clamps or the rod end jam nuts on the drag link.

NOTE: Remember the position and orientation of the clamps.

- Adjust the drag link so that it can be easily inserted into the pitman arm.
- Tighten the ball joint or rod end nut as specified below:
Ball joint - 40-45 ft-lbs.
Rod end - 20-25 ft-lbs.

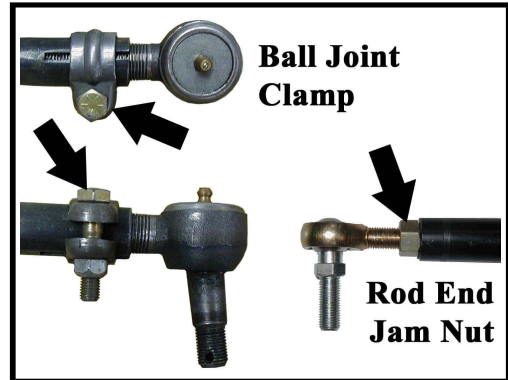

- If equipped with ball joints, position the ball joint clamps in their original location and orientation.
- Tighten the ball joint clamps (28-32 ft. lbs.) or the rod end jam nuts on the drag link.
- Untie the steering wheel and the front wheels.
- Reconnect the main positive and negative cables at the batteries.
- Rotate the steering wheel from a full left turn to a full right turn and make sure that the ball joint clamps do not contact any other component.

⚠ WARNING

If the clamps are positioned so that they contact other components, it may result in steering failure and loss of control of the vehicle causing property damage and/or severe bodily injury.

- Remove the blocks from behind the wheels.
- Release the parking brake and test drive the vehicle.





Front wheel alignment

*NOTE: It is recommended to center the steering before aligning the front wheels. Refer to the **Center the Steering** section for information.*

⚠ WARNING

1. Make sure the key-switch is in the "OFF" position, then remove the key.
2. Place the forward-reverse switch in the center "OFF" position.
3. Set the park brake.
4. Place blocks under the rear wheels to prevent vehicle movement.
5. Disconnect the main positive and negative cables at the batteries.

6. Raise the front of the vehicle and support with jack stands.

⚠ WARNING

Always use a lifting strap, hoist, and jack stands, of adequate capacity to lift and support the vehicle. Failure to use lifting and support devices of rated load capacity may result in severe bodily injury.

7. Turn the front wheels so that they are in the straight ahead position and tie off the steering wheel so that it cannot rotate.

⚠ WARNING

Do not drive the vehicle while the steering wheel or front wheels are tied in position. Driving the vehicle while the steering wheel or front wheels tied in the position may cause loss of control of the vehicle resulting in severe bodily injury and/or property damage.

8. Using a piece of chalk, mark a line around the center of both front tires.

HINT: Hold the chalk on the center of the tire and rotate the tire to mark the line.

9. Loosen the ball joint clamps or the rod end jam nuts on the tie rod.

NOTE: Remember the position and orientation of the ball joint clamps.

10. Lower the front wheels to the ground and push the vehicle back and forth a few feet to settle the suspension.

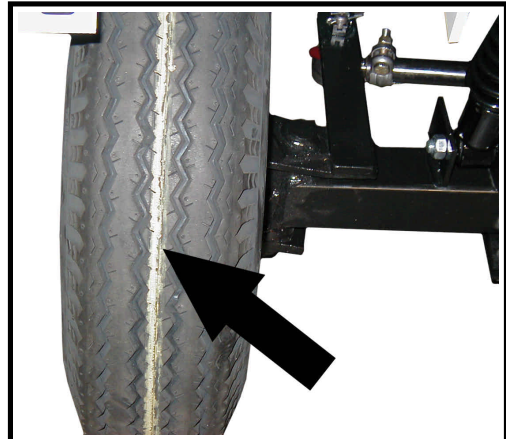

11. Measure the distance between the lines at the front of the tires.
12. Measure the distance between the lines at the rear of the tires.
13. Adjust the tie rod so that the distance at the front and rear of the tires is the same.
14. If equipped with ball joints, position the ball joint clamps in their original location and orientation.
15. Tighten the ball joint clamps (28-32 ft. lbs.) or the rod end jam nuts.
16. Untie the steering wheel.

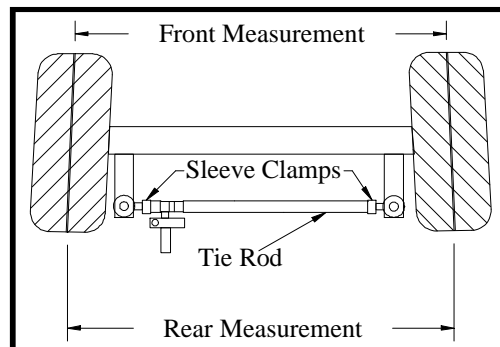

WARNING

Rotate the steering wheel from a full left turn to a full right turn and make sure that the ball joint clamps do not contact any other component. Clamps positioned so that they contact other components may result in steering failure and loss of control of the vehicle causing severe bodily injury and/or property damage.

17. Reconnect the main positive and negative cables at the batteries.
18. Remove the blocks from behind the wheels.
19. Release the parking brake and test drive the vehicle.





INSPECT BALL JOINTS

NOTE: A set of ball joints and/or rod ends will wear at the same rate. If a ball joint and or rod end is worn out, then all should be replaced as a set.

⚠ WARNING

1. Make sure the key-switch is in the "OFF" position, then remove the key.
2. Place the forward-reverse switch in the center "OFF" position.
3. Set the park brake.
4. Place blocks under the rear wheels to prevent vehicle movement.
5. Disconnect the main positive and negative cables at the batteries.

6. Tie off the front wheels so that they cannot turn.

⚠ WARNING

Do not drive the vehicle while the steering wheel or front wheels are tied in position. Driving the vehicle while the steering wheel or front wheels tied in position may cause loss of control of the vehicle resulting in severe bodily injury and/or property damage.

7. While watching the ball joints, rapidly rotate the steering wheel to the left and right.
8. If the ball joint housing moves up or down then the ball joint is worn out and should be replaced. Refer to section **Replacing a Ball Joint** for information regarding replacing ball joints.
9. Untie the front wheels.
10. Reconnect the main positive and negative cables at the batteries.
11. Remove the blocks from behind the wheels.
12. Release the parking brake and test drive the vehicle.

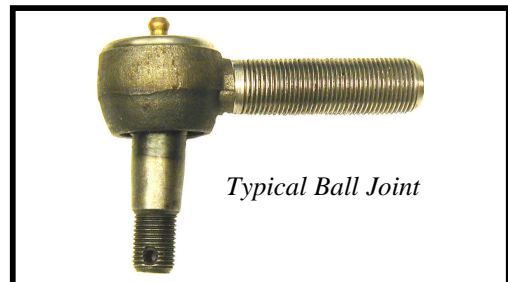

INSPECT ROD ENDS

NOTE: A set of ball joints and/or rod ends will wear at the same rate. If a ball joint and or rod end is worn out, then all should be replaced as a set.

WARNING

1. Make sure the key-switch is in the "OFF" position, then remove the key.
2. Place the forward-reverse switch in the center "OFF" position.
3. Set the park brake.
4. Place blocks under the rear wheels to prevent vehicle movement.
5. Disconnect the main positive and negative cables at the batteries.

6. Visually inspect each rod end for any signs of play between the ball and the nylon or brass bushing in the housing.

WARNING

Do not drive the vehicle while the steering wheel or front wheels are tied in position. Driving the vehicle while the steering wheel or front wheels tied in position may cause loss of control of the vehicle resulting in severe bodily injury and/or property damage.

7. If any play is evident, then the rod end is worn out and should be replaced. Refer to section **Replace the Ball Joints, Tie Rods, and Drag Link** for information regarding replacing ball joints.
8. Reconnect the main positive and negative cables at the batteries.
9. Remove the blocks from behind the wheels.
10. Release the parking brake and test drive the vehicle.

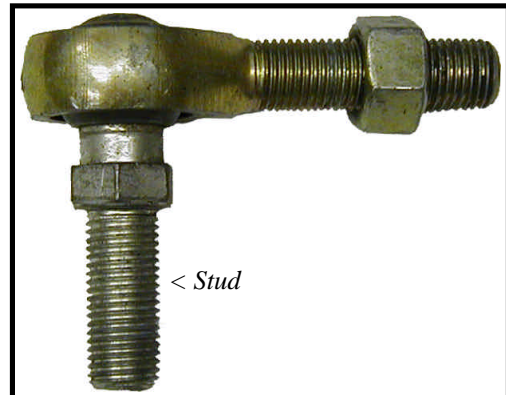

Typical rod end. Studded rod end shown, your vehicle may be equipped with spherical rod ends that do not have a stud.



ADJUST THE STEERING GEAR

*NOTE: In some vehicle configurations it may be necessary to remove the steering gear to perform this procedure. Refer to **Replace the Steering Gear** for information regarding removing the steering gear.*

⚠ WARNING

1. Make sure the key-switch is in the "OFF" position, then remove the key.
2. Place the forward-reverse switch in the center "OFF" position.
3. Set the park brake.
4. Place blocks under the rear wheels to prevent vehicle movement.
5. Disconnect the main positive and negative cables at the batteries.

6. Raise the front of the vehicle and support with jack stands.

⚠ WARNING

Always use a lifting strap, hoist, and jack stands, of adequate capacity to lift and support the vehicle. Failure to use lifting and support devices of rated load capacity may result in serious bodily injury.

7. Disconnect the drag link from the pitman arm.

*NOTE: Refer to **Replace the Ball Joints** section for information regarding removing the ball joint from the drag link.*

8. Loosen the gear lash jam nut and the worm bearing adjuster jam nut.
9. Unscrew the gear lash adjuster all of the way to the stop.
10. Loosen the worm bearing adjuster and then tighten just enough to remove all end play from the input shaft and then an additional 1/8 turn more.

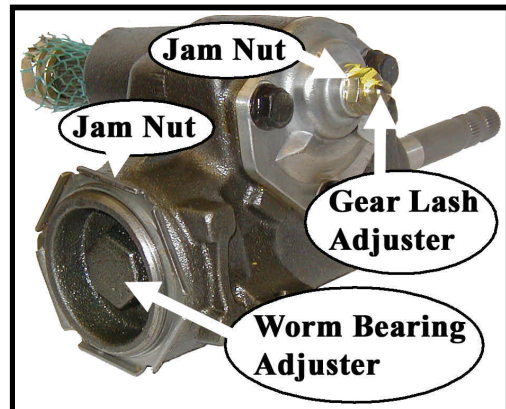

11. While holding the worm bearing adjuster so that it cannot turn, tighten the worm bearing adjuster jam nut.
12. Find the center position of the steering shaft:
 - A. Turn the steering shaft all of the way in one direction.
 - B. While counting the rotations, turn the steering shaft all of the way in the opposite direction.
 - C. Turn the steering shaft 1/2 the number of turns in the original direction.

13. While rotating the input shaft back and forth through its centered position, adjust the gear lash adjusting screw so that there is a slight drag as the steering gear is rotated through its centered position.
14. While holding the gear lash adjusting screw so that it cannot turn, tighten the gear lash adjusting screw jam nut.
15. Reconnect the main positive and negative cables at the batteries.
16. Remove the blocks from behind the wheels.
17. Release the parking brake and test drive the vehicle.





REPLACE THE STEERING SHAFT

⚠ WARNING

1. Make sure the key-switch is in the "OFF" position, then remove the key.
2. Place the forward-reverse switch in the center "OFF" position.
3. Set the park brake.
4. Place blocks under the front wheels to prevent vehicle movement.
5. Disconnect the main positive and negative cables at the batteries.

6. If equipped with a horn switch in the steering wheel, remove the switch, disconnect the wires from the switch and cut the terminals off of the wires.

7. Remove the steering wheel.

*NOTE: Refer to **Replace the Steering Wheel** section for information regarding removing the steering wheel.*

8. Remove the upper steering shaft bushing or bearing from the steering column.

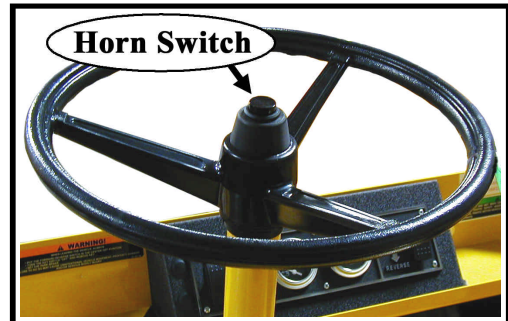

9. Remove the steering gear access cover from the steering column (if equipped).

10. Remove and discard the pinch bolt and nut from the steering shaft coupler.

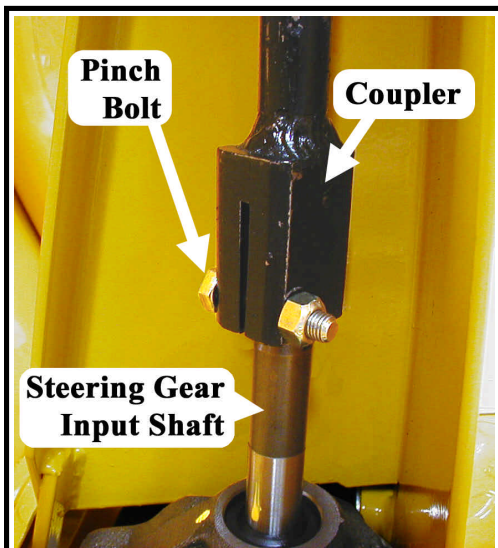
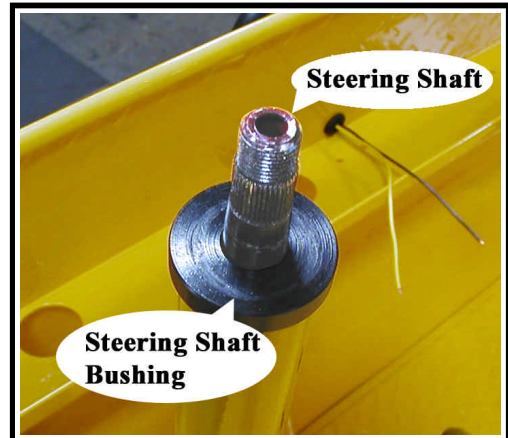

*NOTE Most vehicle configurations will now allow the steering shaft to slide off of the steering gear input shaft and then back down out of the steering column. If there is not enough clearance for this procedure then the steering gear must be removed. Refer to **Replace the Steering Gear** for information regarding removing the steering gear.*

11. Remove the steering shaft from the vehicle.
12. Lightly grease the input shaft splines, steering wheel splines and the upper steering shaft bushing.
13. Install the steering shaft in reverse order using a new pinch bolt. Orientate the shaft so that the pinch bolt is opposite the flat in the steering gear shaft. See the illustration to the right.

⚠ WARNING

Make sure that the pinch bolt is not aligned with the flat on the steering shaft. Aligning the bolt with the flat could result in failure of the steering and loss of control of the vehicle. This could lead to property damage and/or severe bodily injury.

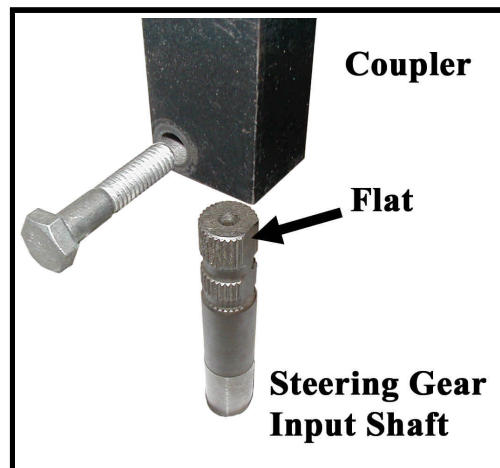

⚠ WARNING

Do not use the original pinch bolt and nut. Failure to replace the pinch bolt and nut may result in failure of the steering causing loss of control of the vehicle. This could lead to property damage and/or severe bodily injury.

14. Tighten the pinch bolt to 24-26 ft-lbs.
15. Reconnect the main positive and negative cables at the batteries.
16. Remove the blocks from behind the wheels.
17. Release the parking brake and test drive the vehicle.





REPLACE THE STEERING WHEEL

⚠ WARNING

- 1. Make sure the key-switch is in the "OFF" position, then remove the key.**
- 2. Place the forward-reverse switch in the center "OFF" position.**
- 3. Set the park brake.**
- 4. Place blocks under the front wheels to prevent vehicle movement.**
- 5. Disconnect the main positive and negative cables at the batteries.**

6. If equipped with a horn switch in the steering wheel, remove the switch and disconnect the wires from the switch.
7. Remove the steering wheel nut.
8. Using a steering wheel puller, remove the steering wheel.
9. Position the front wheels in the straight ahead position.

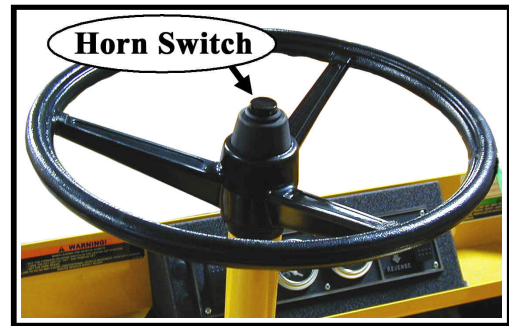

10. Lightly grease the steering wheel splines and install the replacement steering wheel orientated as shown in the illustration to the right.
11. Tighten the steering wheel nut to 28-32 ft lbs.
12. Reinstall the horn switch (if equipped).
13. Reconnect the main positive and negative cables at the batteries.
14. Remove the blocks from behind the wheels.
15. Release the parking brake and test drive the vehicle.



REPLACE THE STEERING GEAR

WARNING

1. Make sure the key-switch is in the "OFF" position, then remove the key.
2. Place the forward-reverse switch in the center "OFF" position.
3. Set the park brake.
4. Place blocks under the rear wheels to prevent vehicle movement.
5. Disconnect the main positive and negative cables at the batteries.

6. Remove the steering wheel. Refer to **Replace the Steering Wheel** section for information regarding removing the steering wheel.
7. Remove the steering shaft. Refer to **Replace the Steering Shaft** section for information regarding removing the steering shaft.
8. Remove the pitman arm using a pickle fork.

*NOTE: On some vehicle configurations it may be required to remove the drag link from the pitman arm. Refer to **Replace the Ball Joints** section for information regarding removing the ball joint from the pitman arm.*

9. Support the steering gear so that it cannot fall out of the vehicle.
10. Remove the bolts holding the steering gear to the vehicle frame and remove the steering gear from the vehicle.

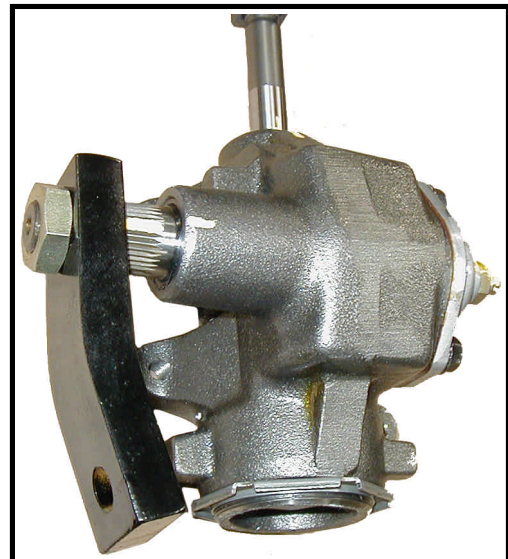

Steering Gear with Pitman Arm

WARNING

Failure to support the steering gear will result in the steering gear falling out of the vehicle and could cause property damage and/or severe bodily injury.

11. Center the steering gear. Refer to **Center the Steering Gear** section for information regarding centering the steering gear.
12. Install in reverse order. Torque the pitman arm nut to 75-100 ft-lbs.
13. Reconnect the main positive and negative cables at the batteries.
14. Remove the blocks from behind the wheels.
15. Release the parking brake and test drive the vehicle.



REPLACE THE BALL JOINTS, TIE RODS, AND DRAG LINK

This section will refer to two different types of ball joints. One type is has a grease fitting and a tapered shaft where it is installed on the steering arm or pitman arm. The second cannot be greased and has a straight shaft. See the illustrations to the right. Depending on the configuration of your vehicle, it may be equipped one or both types of ball joints.

In this text:

The first type will be referred to as a "Ball Joint."

The second type will be referred to as a "Rod End."

NOTE: If a rod end or ball joint is worn out, we recommend replacing all of the ball joints and/or rod ends as a set.

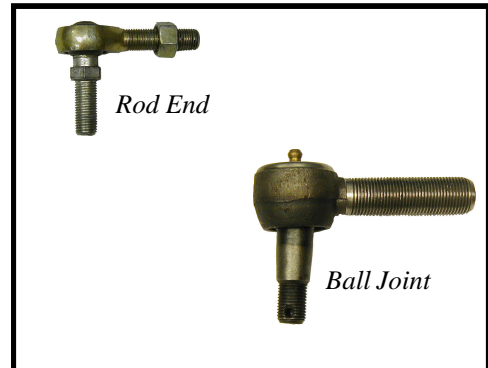

Replacing a Rod End

⚠ WARNING

1. Make sure the key-switch is in the "OFF" position, then remove the key.
2. Place the forward-reverse switch in the center "OFF" position.
3. Set the park brake.
4. Place blocks under the rear wheels to prevent vehicle movement.
5. Disconnect the main positive and negative cables at the batteries.

6. Raise the front of the vehicle and support with jack stands.

⚠ WARNING

Always use a lifting strap, hoist, and jack stands, of adequate capacity to lift and support the vehicle. Failure to use lifting and support devices of rated load capacity may result in severe bodily injury.

7. Loosen the rod end jam nut or clamp on the steering sleeve.
8. Remove the rod end nut.
9. Remove the rod end from the steering arm.

HINT: Count the number of turns required to remove the rod end from the steering sleeve. This will make it easier to realign the wheels.

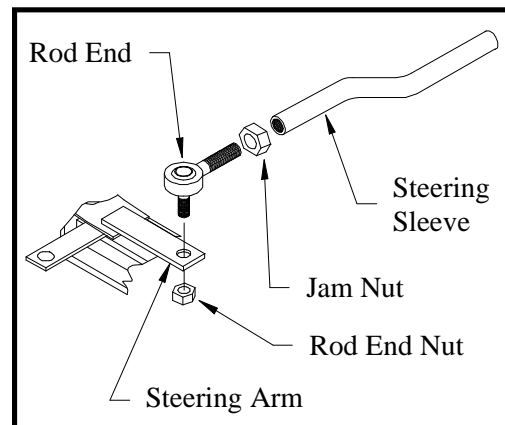

10. Install the new rod end into the steering sleeve. Screw it into the sleeve the same number of turns counted in the previous step. Do not tighten the rod end clamp or jam nut at this time.
11. Install the rod end into the steering arm. Tighten the rod end nut to 20-25 ft-lbs.
12. Realign the front wheels.

*NOTE: Refer to the **Steering** section for information regarding realignment of the front wheels.*

13. Lower the vehicle.
14. Reconnect the main positive and negative cables at the batteries.
15. Remove the blocks from behind the wheels.
16. Release the park brake and test drive the vehicle.

Replacing a Ball Joint

WARNING

1. Make sure the key-switch is in the "OFF" position, then remove the key.
2. Place the forward-reverse switch in the center "OFF" position.
3. Set the park brake.
4. Place blocks under the rear wheels to prevent vehicle movement.
5. Disconnect the main positive and negative cables at the batteries.

6. Raise the front of the vehicle and support with jack stands.

WARNING

Always use a lifting strap, hoist, and jack stands, of adequate capacity to lift and support the vehicle. Failure to use lifting and support devices of rated load capacity may result in severe bodily injury.

7. Loosen the ball joint clamp on the steering sleeve.
8. Remove the cotter pin and ball joint nut.
9. Using a pickle fork, remove the ball joint from the steering arm.
10. Remove the ball joint from the steering sleeve.

HINT: Count the number of turns required to remove the ball joint from the sleeve. This will make it easier to realign the wheels.

11. Install the new ball joint into the steering sleeve. Screw it into the sleeve the same number of turns counted in the previous step. Do not tighten the ball joint clamp at this time.

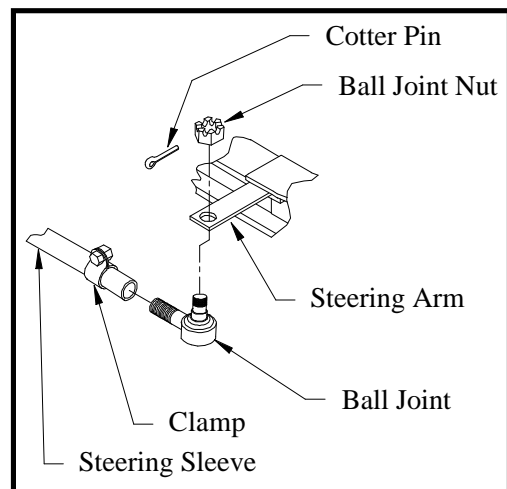



Maintenance, Service, and Repair

12. Install the ball joint into the steering arm. Tighten the ball joint nut to 40-45 ft-lbs. and install a new cotter pin.

13. Realign the front wheels.

*NOTE: Refer to the **Steering** section for information regarding realignment of the front wheels.*

14. Lower the vehicle.

15. Reconnect the main positive and negative cables at the batteries.

16. Remove the blocks from behind the wheels.

17. Release the park brake and test drive the vehicle.

Replacing the Drag Link

The Drag Link is the linkage that connects the steering gear pitman arm to the steering knuckle. Refer to the illustration on the following page.

⚠ WARNING

- 1. Make sure the key-switch is in the "OFF" position, then remove the key.**
- 2. Place the forward-reverse switch in the center "OFF" position.**
- 3. Set the park brake.**
- 4. Place blocks under the rear wheels to prevent vehicle movement.**
- 5. Disconnect the main positive and negative cables at the batteries.**

6. Raise the front of the vehicle and support with jack stands.

⚠ WARNING

Always use a lifting strap, hoist, and jack stands, of adequate capacity to lift and support the vehicle. Failure to use lifting and support devices of rated load capacity may result in severe bodily injury.

7. Remove the ball joints or rod ends from the steering knuckle and pitman arm.

*NOTE: Refer to the **Replacing the Ball Joints** section for information regarding the removal of the ball joints or rod ends.*

8. Remove the drag link as an assembly.

9. Install in reverse order.

10. Realign the front wheels.

*NOTE: Refer to the **Steering** section for information regarding realignment of the front wheels.*

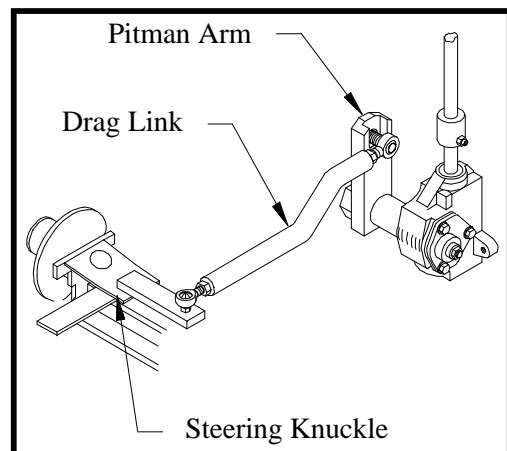

Typical Drag Link

11. Lower the vehicle.
12. Reconnect the main positive and negative cables at the batteries.
13. Remove the blocks from behind the wheels.
14. Release the park brake and test drive the vehicle.

Replacing the Tie Rod

The Tie Rod is the linkage that connects the two steering knuckles together. Refer to the illustration below..

⚠ WARNING

1. Make sure the key-switch is in the "OFF" position, then remove the key.
2. Place the forward-reverse switch in the center "OFF" position.
3. Set the park brake.
4. Place blocks under the rear wheels to prevent vehicle movement.
5. Disconnect the main positive and negative cables at the batteries.

6. Raise the front of the vehicle and support with jack stands.

⚠ WARNING

Always use a lifting strap, hoist, and jack stands, of adequate capacity to lift and support the vehicle. Failure to use lifting and support devices of rated load capacity may result in severe bodily injury.

7. Remove the ball joints or rod ends from the steering knuckles.

*NOTE: Refer to the **Replacing the Ball Joints** section for information regarding the removal of the ball joints or rod ends.*

8. Remove the tie rod as an assembly.
9. Install in reverse order.
10. Realign the front wheels.

*NOTE: Refer to the **Steering** section for information regarding realignment of the front wheels.*

11. Lower the vehicle.
12. Reconnect the main positive and negative cables at the batteries.
13. Remove the blocks from behind the wheels.
14. Release the park brake and test drive the vehicle.

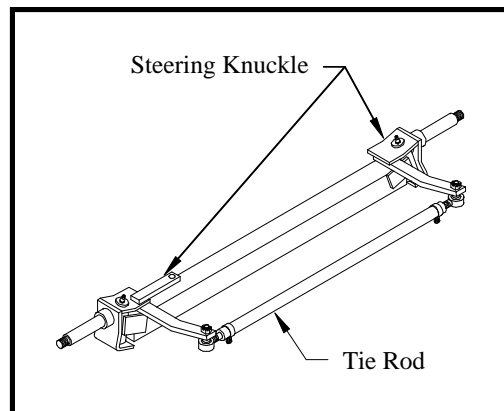

Typical Front Axle Assembly



CENTER THE STEERING GEAR

1. Remove the pitman arm.
2. Rotate the input shaft clockwise until it stops.
3. While counting the rotations, rotate the input shaft counter clockwise until it stops.
4. Rotate the input shaft clockwise 1/2 the rotations counted in the previous step.
5. Mark the steering gear input shaft and pitman shaft in relation to the housing for reference.

PITMAN SHAFT ALIGNMENT

⚠ WARNING

1. Make sure the key-switch is in the "OFF" position, then remove the key.
2. Place the forward-reverse switch in the center "OFF" position.
3. Set the park brake.
4. Place blocks under the rear wheels to prevent vehicle movement.
5. Disconnect the main positive and negative cables at the batteries.

6. Raise the front of the vehicle and support with jack stands.

⚠ WARNING

Always use a lifting strap, hoist, and jack stands, of adequate capacity to lift and support the vehicle. Failure to use lifting and support devices of rated load capacity may result in severe bodily injury.

7. Center the steering gear. Refer to ***Center the Steering Gear*** section for information regarding centering the steering gear.
8. Screw both steering stops all of the way in.
9. Install the pitman arm so that it is centered between the steering stops.
10. Realign the front wheels. Refer to ***Front End Alignment*** section for information regarding aligning the front wheels.
11. Adjust the steering stops so that the front wheels do not contact any part of the frame, suspension or steering linkages and the left and right turning radiuses are equal.
12. Tighten the steering stop jam nuts.
13. Lower the vehicle.
14. Reconnect the main positive and negative cables at the batteries.
15. Remove the blocks from behind the wheels.
16. Release the park brake and test drive the vehicle.

REPAIR THE STEERING GEAR

Disassembly

*NOTE: The steering gear must be removed from the vehicle for this procedure. Refer to **Replace the Steering Gear** section for information regarding removing the steering gear.*

NOTE: The steering gear is packed with grease. Only perform maintenance on the steering gear in an area that will contain any grease that may spill out of the steering gear when it is disassembled.

Refer to the illustration at the end of this section for a blown up view of the steering gear assembly.

1. Center the steering gear.
 - A. Turn the steering shaft all of the way in one direction.
 - B. While counting the rotation, turn the steering shaft all of the way in the opposite direction.
 - C. Turn the steering shaft 1/2 the number of turns in the original direction.
2. Remove the worm bearing adjuster locking ring and the worm bearing adjuster.



3. Remove the side cover/pitman shaft assembly by removing the three side cover bolts and then pulling the assembly out of the housing.

NOTE: The side cover/pitman shaft assembly normally does not have to be disassembled.

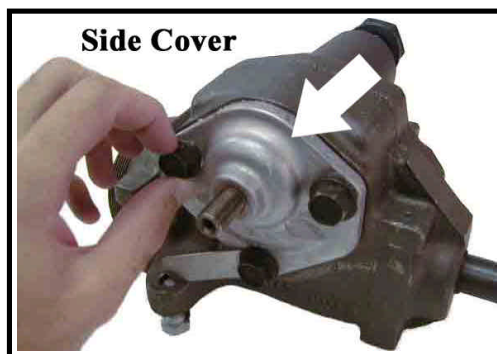



Maintenance, Service, and Repair

4. Remove the worm shaft and ball nut assembly from the bottom of the housing.
5. Remove the worm shaft seal.
6. Remove the pitman shaft seal.
7. Remove the upper worm bearing and bearing cup from the housing.



8. The ball nut assembly consists of two sets of ball bearings that recirculate in two channels in the ball nut housing. The bearings may fall out once the bearing guides are removed. Be careful not to lose any of the bearings.
9. Remove the ball guide clamps, ball guides and all of the ball bearings.
10. Remove the ball nut from the worm shaft.
11. Thoroughly clean and inspect all parts for signs of corrosion, damage or wear and replace as required.

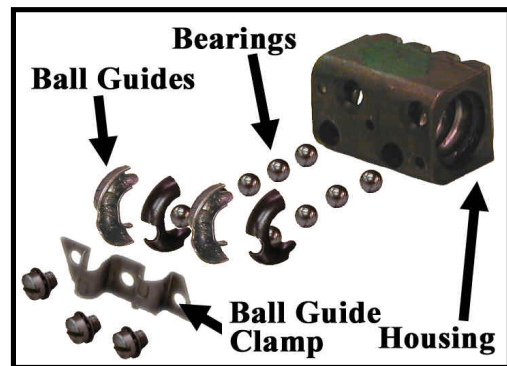

Reassembly

1. Lightly lubricate all parts before reassembly.
2. Install a new worm shaft seal and pitman shaft seal into the housing.
3. Install the upper worm bearing cup.
4. Divide the ball bearing into two equal groups.
5. Position the ball nut onto the worm as shaft as shown in the illustration.
6. Insert the ball guides into the ball nut.
7. Insert each group of bearings into the ball guides.

NOTE: Do not rotate the worm shaft while installing the bearings. This may cause one or more of the bearings to enter the crossover passage in the ball nut, causing improper operation.

8. Install the ball guide clamp.



9. Place the upper worm bearing on the worm shaft and install the worm shaft/ball nut assembly into the housing being careful not to damage the worm shaft seal.

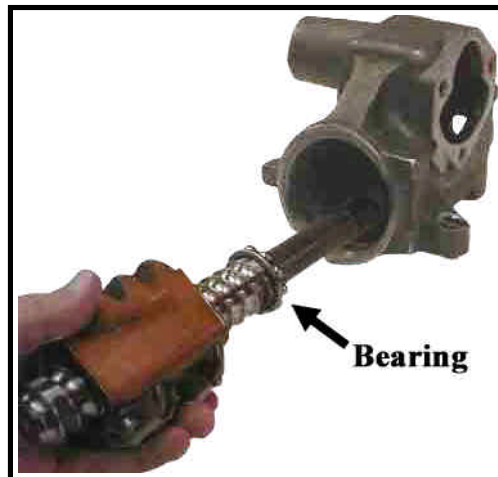

10. Install the assembled worm bearing adjuster into the housing and tighten just enough to remove all play in the worm shaft.
11. Install, but do not tighten the worm bearing adjuster lock nut.
12. Rotate the worm shaft to center the ball nut in the housing.
13. Place a new gasket onto the housing and install the assembled pitman shaft/side cover onto the housing using two of the three mounting bolts.
14. Pack the steering gear with grease through the open side cover bolt hole and then install the bolt.
15. Adjust the steering gear.



*NOTE: Refer to **Adjust the Steering gear** section for information regarding adjusting the steering gear.*

16. Once the adjustments are completed, make sure that the locking ring and jam nut are tight.





Exploded View of Steering Gear

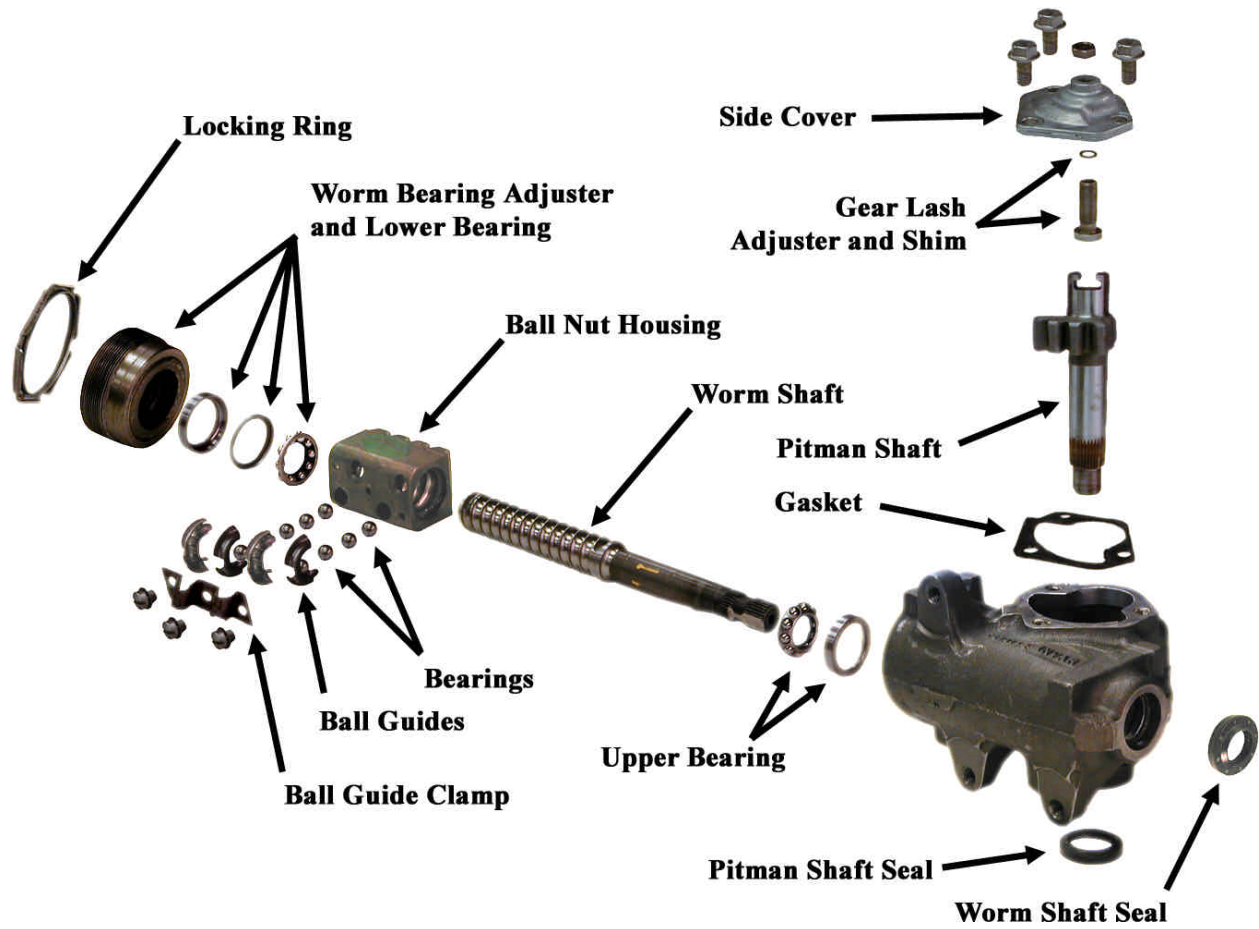

Brake Service

TABLE OF CONTENTS

Inspect the Service Brake	2
Disc Brake Pads	2
Disc Brake Rotor	3
Inspect the Parking brake	4
Wheel Park Brake (hydraulic disc)	4
Electric Motor Brake	5
Adjust the Service Brakes	6
Two or Four Wheel Hydraulic Disc Brakes	6
Adjust the Parking Brake	7
Wheel Park Brake (hydraulic disc)	7
Check Master Cylinder Fluid	8
Bleed the Brake System	9
Flush the Brake System	11
Replace the Parking Brake Lining (electric motor brake)	12
Inspection:	14
Replace Front Disc Brake Pads	15
Replace Rear Brake Pads	17
Hydraulic Disc	17
Replace the Wheel Cylinder	19
Disc Brake Body Assembly (front or rear)	19
Repair the Brake Body	21
Replace the Master Cylinder	23
Repair the Master Cylinder	25

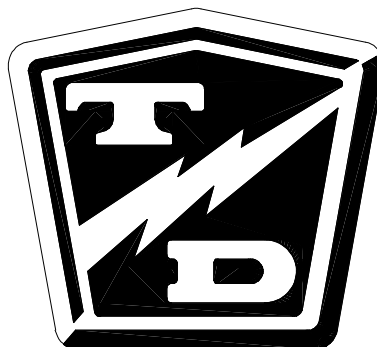



INSPECT THE SERVICE BRAKE

Disc Brake Pads

⚠ WARNING

Current Taylor-Dunn® brakes are asbestos free. However, there is the possibility that the original brakes were replaced with aftermarket parts containing asbestos. Since this possibility exists, all brake parts should be handled as if they contain asbestos. Refer to Appendix C for recommended handling precautions.

*NOTE: The brake pad must be removed to accurately measure the lining thickness. Refer to **Replace the Front or Rear Brake Pads** section for information on removing the brake pads.*

Measure the brake pad lining at the thinnest point on the pad. If the brake pad lining is 1/16-inch or less then the brake pad must be replaced.

It is recommended to replace the left and right side brake pads as a set.

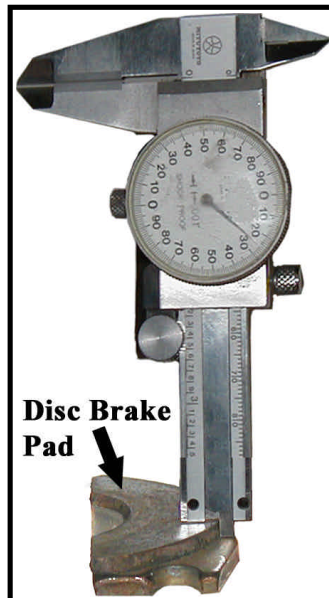

Disc Brake Rotor

⚠ WARNING

Current Taylor-Dunn® brakes are asbestos free. However, there is the possibility that the original brakes were replaced with aftermarket parts containing asbestos. Since this possibility exists, all brake parts should be handled as if they contain asbestos. Refer to Appendix C for recommended handling precautions.

*NOTE: The front brake rotor is an integral part of the front hub. If the brake rotor is worn beyond its service limits, then the front hub must be replaced. Refer to **Front Axle Service** for information on replacing the front hub.*

*NOTE: Depending on the rear axle configuration, the rear brake rotor may be an integral part of the rear axle. If the brake rotor is worn beyond its service limits, then the rear axle must be replaced. Refer to **Transmission** section for information regarding replacing the rear axle*

*NOTE: The wheel must be removed to accurately measure the rotor thickness. Refer to **Tires and Wheels** section for information on removing the wheel.*

1. Measure the run out of the rotor at its maximum diameter. If the run out exceeds 0.005, then the rotor must be machined. Do not machine the rotor beyond its service limits.

NOTE: A bent axle or damaged rear axle could cause excessive brake rotor run out.

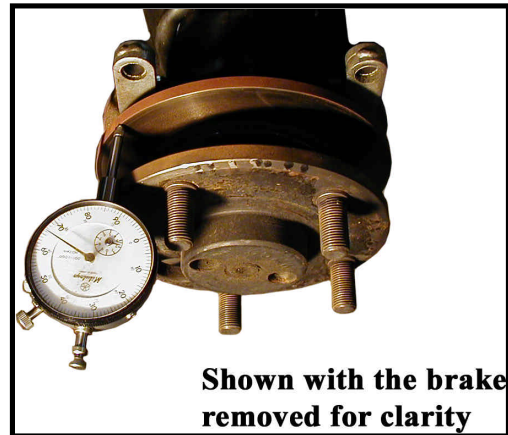

2. Measure the thickness of the brake rotor in 3 places. If the brake rotor thickness is less than 0.20-inches, then the rotor must be replaced.

⚠ WARNING

Do not use a rotor that is worn beyond its service limits. A rotor worn beyond its service limits could fail and cause loss of brakes resulting in severe bodily injury and/or property damage.

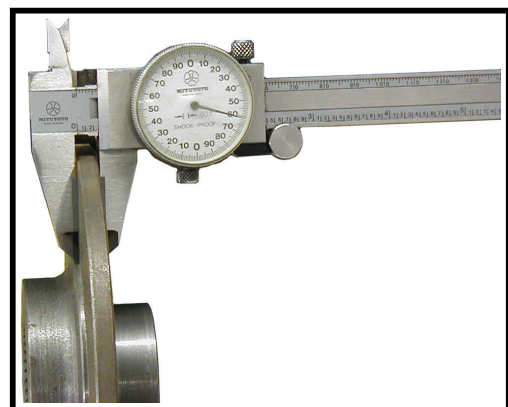



INSPECT THE PARKING BRAKE

Wheel Park Brake (hydraulic disc)

NOTE: The parking brake is actuated through a pin in the center of the rear left and right brake body on the rear axles.

⚠ WARNING

1. Make sure the key-switch is in the "OFF" position, then remove the key.
2. Place the forward-reverse switch in the center "OFF" position.
3. Set the park brake.
4. Place blocks under the front wheels to prevent vehicle movement.
5. Disconnect the main positive and negative cables at the batteries.

6. Release the park brake.
7. Inspect the brake pads. Refer to **Inspect the Service Brake** section to inspect the brake pads.
8. Inspect the park brake pin and bushing for any signs of damage or corrosion.

*NOTE: The park brake pin is inside of the brake body. Refer to **Repair the Brake Body** for information on removing the park brake pin.*

9. Inspect all brake cables and linkages for any signs of damage, wear, or missing cotter pins.

10. Inspect the brake handle locking mechanism for any signs of damage.

*NOTE: Refer to **Adjust the Parking Brake** section for information regarding adjusting the parking brake.*

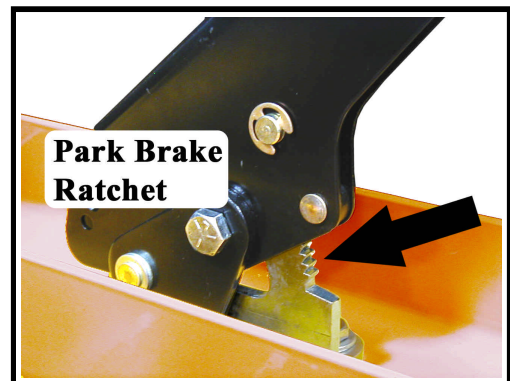
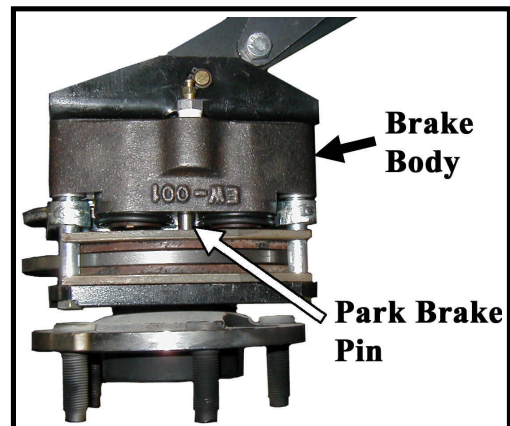

⚠ WARNING

If any sign of damage or wear is found on the locking mechanism, cables, or linkages then they must be repaired or replaced immediately. Failure to repair or replace any damaged component could result in failure of the park brake causing property damage and/or severe bodily injury.

Electric Motor Brake

A variable power supply capable of supplying 0-volts to 24-volts DC at 2-Amps will be required to perform the testing.

The brake does not have to be removed from the transmission for this test.

⚠ WARNING

- 1. Make sure the key-switch is in the "OFF" position, then remove the key.**
- 2. Place the forward-reverse switch in the center "OFF" position.**
- 3. If equipped with a hand or foot park brake, set the park brake.**
- 4. Place blocks under the front wheels to prevent vehicle movement.**
- 5. Disconnect the main positive and negative cables at the batteries.**

6. Disconnect the electric brake connector from the vehicles harness.
7. Adjust the power supply to zero volts.
8. Connect the power supply to the electric brake.
9. Slowly increase the voltage until you hear a 'click' from the brake. The 'click' is the brake releasing. The motor should now be free to rotate limited by the gear train and parking brake).
 - a) If the brake does not release until the voltage exceeds 18-volts, then the friction plate has worn beyond its service limits and must be replaced.
 - b) If the brake does not release at all, then the brake electromagnet has failed and must be replaced.
10. Reconnect the electric brake.
11. Reconnect the main positive and negative cables at the batteries.
12. Remove blocks from behind the wheels.
13. Release the parking brake and test drive the vehicle.





ADJUST THE SERVICE BRAKES

Two or Four Wheel Hydraulic Disc Brakes

The hydraulic disc brake system is automatically adjusted. A low brake pedal or lack of braking power could be caused by:

- Brake fluid level low in the master cylinder. See ***Check the Master Cylinder Fluid*** section.
- Air in the brake lines. See ***Bleed the Brakes*** section.
- Worn brake pads. See ***Inspect the Service Brake*** section.
- Worn brake rotor. See ***Inspect the Service Brake*** section.
- Binding brake pedal linkage.

If you are experiencing a low brake pedal or lack of braking power, the entire brake system should be inspected.



ADJUST THE PARKING BRAKE

Wheel Park Brake (hydraulic disc)

The parking brake is actuated through a pin in the center of the rear left and right brake body on the rear axles.

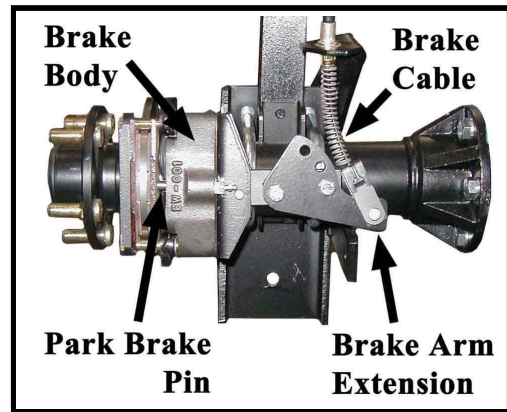

⚠ WARNING

1. Make sure the key-switch is in the "OFF" position, then remove the key.
2. Place the forward-reverse switch in the center "OFF" position.
3. Set the park brake.
4. Place blocks under the front wheels to prevent vehicle movement.
5. Disconnect the main positive and negative cables at the batteries.

6. Release the park brake.
7. Loosen the jam nuts on the Primary Adjustment Rod.
8. Tighten the Primary Adjustment Rod until it is difficult to rotate the brake arm clevis pin on both wheels.
9. Loosen the Primary adjustment rod one to two turns so that both wheels rotate with no brake drag.

⚠ WARNING

The threaded rod must be screwed into the clevis with at least 3/8" of threads. Less than 3/8" of threads in a clevis could result in brake failure causing severe bodily injury and/or property damage.

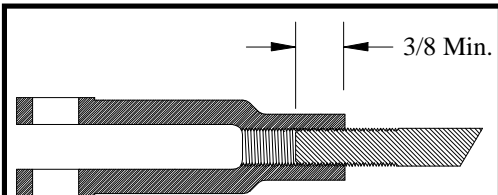

Cutaway of Clevis and Threaded Rod

NOTE: If there is no adjustment left in the Primary Adjustment Rod, then the Brake Arm Extension must be rotated to engage the next hole in the arm.

10. Tighten the jam nuts on the park brake linkage.
11. Set the park brake.
12. Reconnect the main positive and negative cables at the batteries.
13. Remove blocks from behind the wheels.
14. Release the park brake and test drive the vehicle.



CHECK MASTER CYLINDER FLUID

⚠ WARNING

Do not ingest brake fluid or allow contact with skin or eyes. Always wear protective clothing and a face shield when working with or around brake fluid.

SKIN CONTACT

Flush area immediately with water for several minutes. If a rash or skin irritation develops, get medical attention immediately.

EYE CONTACT

Immediately flush the eye with water for 15 minutes and call physician.

INGESTION

Get medical attention immediately.

⚠ WARNING

1. Make sure the key-switch is in the "OFF" position, then remove the key.
2. Place the forward-reverse switch in the center "OFF" position.
3. Set the park brake.
4. Place blocks under the front wheels to prevent vehicle movement.
5. Disconnect the main positive and negative cables at the batteries.

6. Thoroughly clean the area around the master cylinder cap.
7. Remove the master cylinder cap.
8. If the fluid in the master cylinder is contaminated then the entire brake system must be flushed. Refer to **Bleed the Brakes** for information regarding flushing the brake system.
9. Fill with brake fluid from a new sealed container to within 1/4-inch of the top of the master cylinder chamber and reinstall the cap.
10. Reconnect the main positive and negative cables at the batteries.
11. Remove blocks from behind the wheels.
12. Release the parking brake and test drive the vehicle.

⚠ WARNING

- Only use DOT 3 brake fluid from a new sealed container.
- DOT 3 brake fluid is corrosive and will damage paint finishes.
- Dispose of brake fluid in accordance with local state and federal regulations.
- Read and follow all warnings on the brake fluid container.

BLEED THE BRAKE SYSTEM

⚠ WARNING

Do not ingest brake fluid or allow contact with skin or eyes. Always wear protective clothing and a face shield when working with or around brake fluid.

SKIN CONTACT

Flush area immediately with water for several minutes. If a rash or skin irritation develops, get medical attention immediately.

EYE CONTACT

Immediately flush the eye with water for 15 minutes and call physician.

INGESTION

Get medical attention immediately.

NOTE: Start this procedure at the wheel furthest from the master cylinder, then work toward the wheel closest to the master cylinder.

⚠ WARNING

1. Make sure the key-switch is in the "OFF" position, then remove the key.
2. Place the forward-reverse switch in the center "OFF" position.
3. Set the park brake.
4. Place blocks under the front wheels to prevent vehicle movement.
5. Disconnect the main positive and negative cables at the batteries.

6. Thoroughly clean the area around the master cylinder cap and remove the cap.



Master cylinder is located between the front seats. Dual reservoir shown.

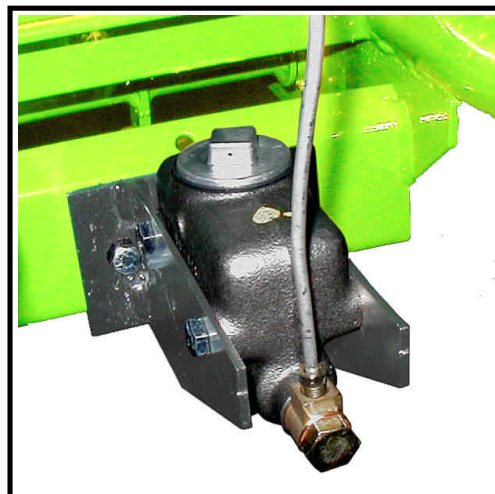

Single reservoir master cylinder



Maintenance, Service, and Repair

7. Add brake fluid from a new sealed container to the master cylinder. Fill to 1/4" from the top of the master cylinder chamber.

⚠ WARNING

- **Only use DOT 3 brake fluid from a new sealed container.**
- **DOT 3 brake fluid is corrosive and will damage paint finishes.**
- **Dispose of brake fluid in accordance with local state and federal regulations.**
- **Read and follow all warnings on the brake fluid container.**

8. The master cylinder fluid level will drop as the brakes are bled. Periodically check and fill the master cylinder during this procedure. Do not allow the fluid level in the master cylinder to drop too low as this will allow air into the brake lines.
9. Attach a clear hose to the bleeder valve on the brake cylinder that is to be bled. Route the hose into a clear container for waste brake fluid.
10. Pump the brake pedal a few times and then press and hold light pressure to the brake pedal.
11. Open the bleeder valve on the hydraulic brake body.
12. Depress the foot pedal to the floor and then close the bleeder valve. Do not release pressure on the brake pedal until the bleeder valve is closed.
13. Slowly release the foot pedal, allowing it to return to its released position.

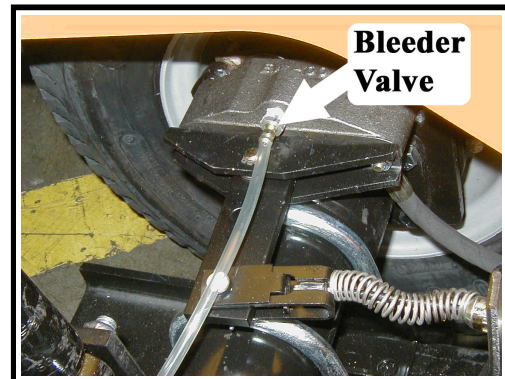

Bleeder valve with hose attached

NOTE: Check and fill the master cylinder frequently during the bleeding process. Do not allow the fluid level in the master cylinder to drop low enough to allow air to enter the brake lines. If air enters the brake lines during the bleeding process, then you will have to start again from the beginning.

⚠ WARNING

Always use brake fluid from a new sealed container. Never reuse any brake fluid that has been removed from the brake system. Use of contaminated brake fluid will degrade the braking performance and may cause property damage or severe bodily injury.

14. Repeat the above steps until you are sure that all of the air is expelled from the brake line. Any air bubbles that can be seen in the clear hose attached to the bleeder is an indication that there is still air in the brake lines.
15. Repeat this process with each of the other wheels.

*NOTE: When finished, top off the master cylinder with fluid. See **Check Master Cylinder Fluid** for information on filling the master cylinder.*

16. Reconnect the main positive and negative cables at the batteries.
17. Remove the blocks from behind the wheels.
18. Release the park brake and test drive the vehicle.

FLUSH THE BRAKE SYSTEM

WARNING

1. Make sure the key-switch is in the "OFF" position, then remove the key.
2. Place the forward-reverse switch in the center "OFF" position.
3. Set the park brake.
4. Place blocks under the front wheels to prevent vehicle movement.
5. Disconnect the main positive and negative cables at the batteries.

6. Raise the rear wheels off of the ground and support with jack stands.

WARNING

Always use a lifting strap, hoist, and jack stands, of adequate capacity to lift and support the vehicle. Failure to use lifting and support devices of rated load capacity may result in severe bodily injury.

7. If equipped with front brakes, raise the front wheels off of the ground and support with jack stands.
8. Release the park brake.
9. Remove both rear wheels and, if equipped with front brakes, the front wheels. Refer to **Tires and Wheels** section for information regarding removing the wheels.
10. Remove the wheel cylinders from each axle. Refer to **Replace the Wheel Cylinder** section for information regarding removing the wheel cylinder.
11. Attach a clear hose to the bleeder valve on each of the wheel cylinders and route the hoses into a container for waste brake fluid.
12. Position the wheel cylinders so that the bleeder screw is pointing to the ground and open all bleeder screws.
13. Pump the master cylinder until all fluid has been pumped from the brake lines and all wheel cylinders.
14. Close all bleeder screws.
15. Fill the master cylinder with fluid.
16. Open one of the bleeder screws and pump the master cylinder until all fluid has been pumped from the master cylinder and close the bleeder screw.
17. Repeat the above two steps for each wheel cylinder.
18. Reinstall the wheel cylinders and bleed the brakes. Refer to **Bleed the Brakes** for information regarding bleeding the brakes.
19. Set the park brake.
20. Install the wheels and lower the vehicle to the ground.
21. Reconnect the main positive and negative cables at the batteries.
22. Release the park brake and test drive the vehicle.



REPLACE THE PARKING BRAKE LINING (ELECTRIC MOTOR BRAKE)

⚠ WARNING

Current Taylor-Dunn® brakes are asbestos free. However, there is the possibility that the original brakes were replaced with aftermarket parts containing asbestos. Since this possibility exists, all brake parts should be handled as if they contain asbestos. Refer to appendix C for recommended handling precautions.

1. Remove the electric brake assembly from the drive. Refer to *Motor Removal and Installation* in the *Transmission* section for information regarding removing the brake.
2. Place the brake assembly on flat surface with the shaft pointing up.
3. Mark the orientation of the outer housing and magnet. This mark will be used to correctly align the housing during reassembly

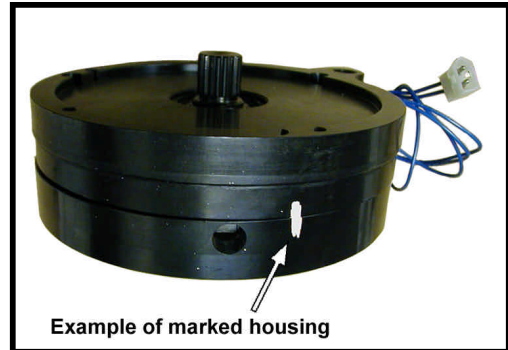

4. Remove the three Allen head socket screws evenly so that the internal spring pressure is reduced gradually. Turn each screw no more than two turns at a time.
5. Remove the outer housing and friction plate.

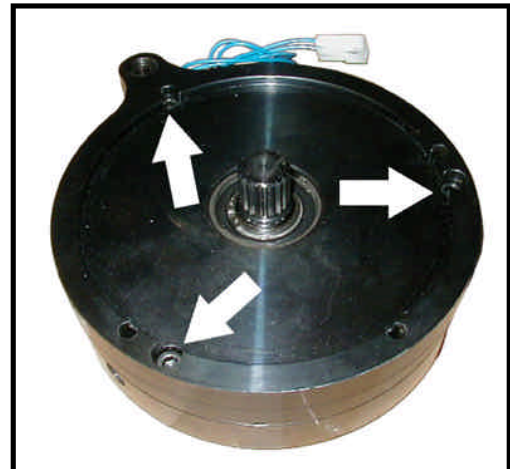

6. Mark the orientation of the inner contact plate in relation to the magnet.

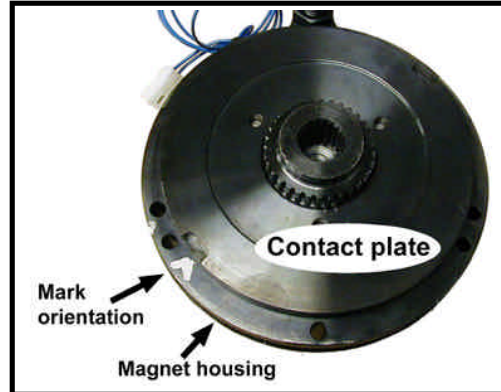

7. Remove the smaller bearing circlip.
8. Using a soft hammer, drive out the center hub and remove the inner contact plate and six springs.
9. If required, remove the larger bearing circlip and press out the bearing. If the bearing is removed it must be replaced.
10. Thoroughly clean all parts.
11. Inspect all parts for damage or wear.
12. Reassemble in reverse order.

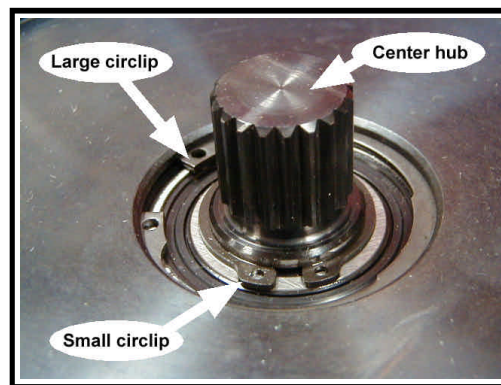

Reassembly Notes

- a. Orientate the inner contact plate lining up the marks made when removed and so that the notches face away from the magnet (see illustration below).
- b. Orientate the friction plate so that the cutout faces the inner contact plate.
- c. Orientate the outer housing lining up the marks made when it was removed.
- d. Tighten the three Allen head socket screws in a cross pattern evenly so that the internal spring pressure is increased gradually. Turn each screw no more than two turns at a time. Final torque-10 ft-lbs.

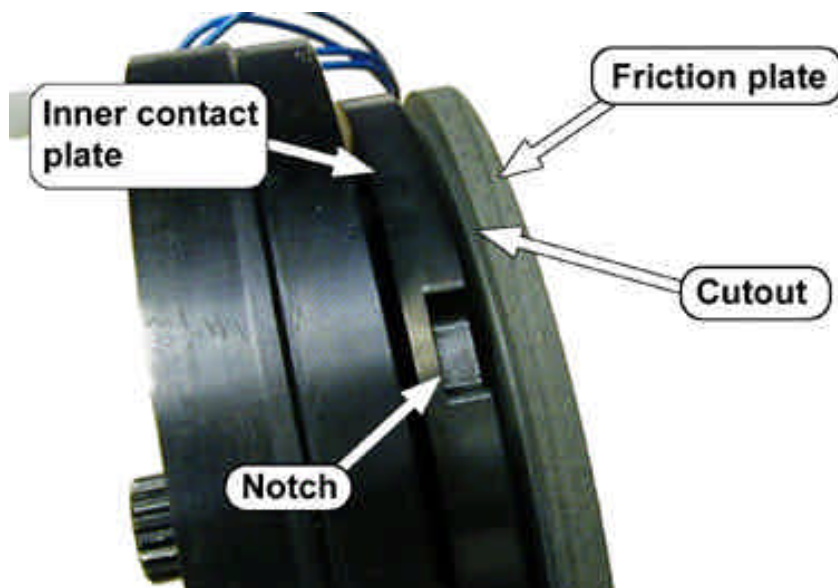

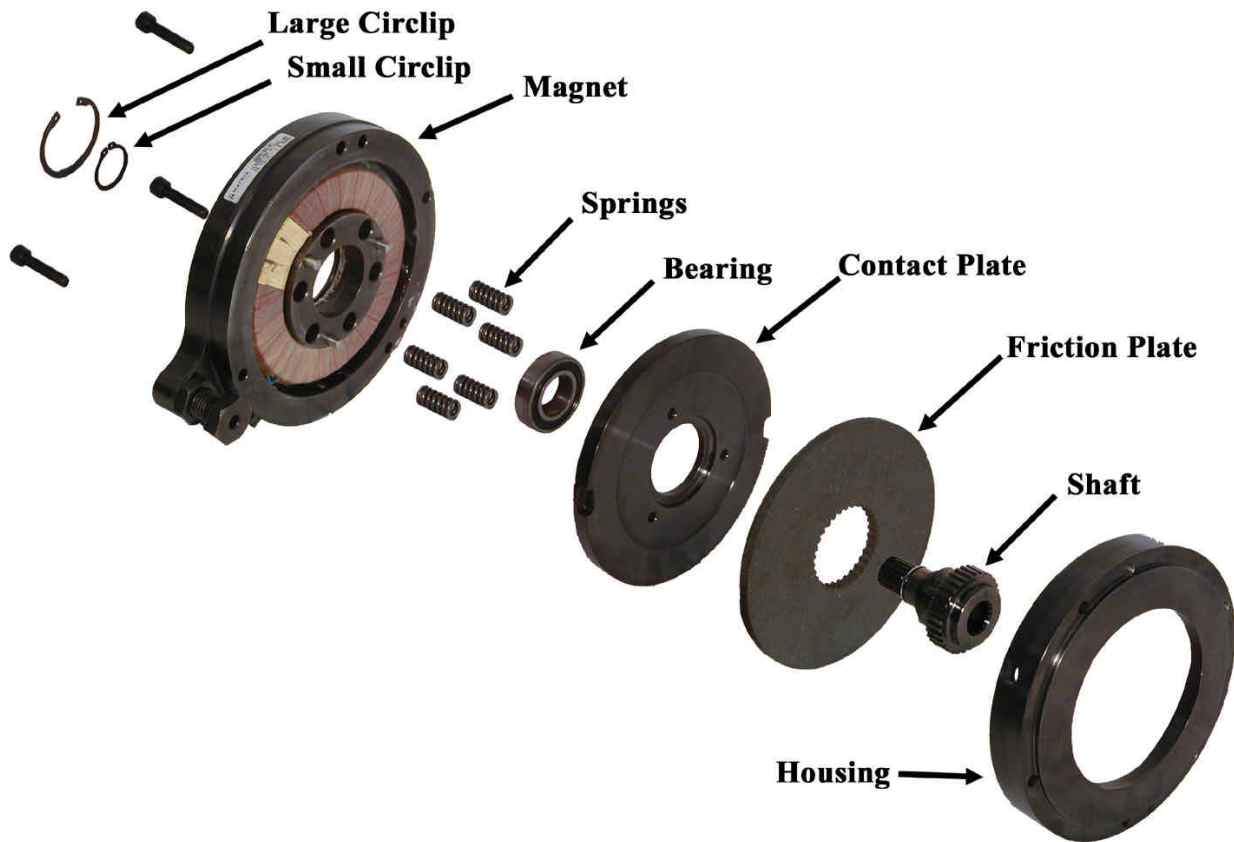

Electric motor brake exploded

Inspection:

Note: There are no repairable parts in this assembly. The parts must be replaced if any damage or wear is found.

1. Measure the free length of the five springs. Minimum length = 0.713"
2. Inspect the splines on the hub and the friction plate for damage.
3. Inspect the inner contact plate and the outer housing where they come into contact with the friction plate for wear or damage.
4. Inspect the three dowel pins and their corresponding holes in the inner contact plate. The dowel pins should be straight and the holes should be round.
5. Inspect the bearing for excessive play or roughness when rotated.
6. Inspect the contact surfaces of the magnet and inner contact plate for damage and flatness.

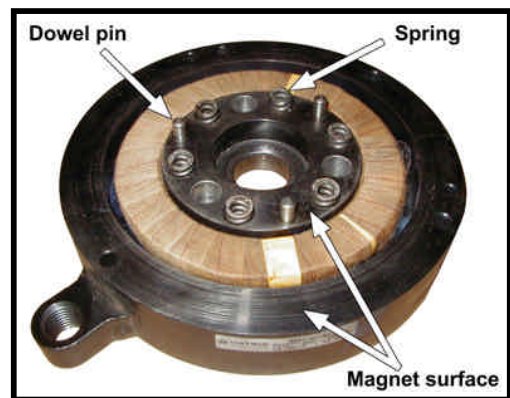

REPLACE FRONT DISC BRAKE PADS

NOTE: It is recommended that both the left and right brake pads be replaced as a set.

⚠ WARNING

Current Taylor-Dunn® brakes are asbestos free. However, there is the possibility that the original brakes were replaced with aftermarket parts containing asbestos. Since this possibility exists, all brake parts should be handled as if they contain asbestos. Refer to appendix C for recommended handling precautions.

NOTE: Installing new brake pads will raise the brake fluid level in the master cylinder.

⚠ WARNING

- 1. Make sure the key-switch is in the "OFF" position, then remove the key.**
- 2. Place the forward-reverse switch in the center "OFF" position.**
- 3. Set the park brake.**
- 4. Place blocks under the rear wheels to prevent vehicle movement.**
- 5. Disconnect the main positive and negative cables at the batteries.**

6. Thoroughly clean the area around the master cylinder cap.
7. Remove fluid from the master cylinder until it is 1/2 full.



Master cylinder is located between the front seats. Dual reservoir shown.

8. Raise the front of the vehicle and support with jack stands.

⚠ WARNING

Always use a lifting strap, hoist, and jack stands, of adequate capacity to lift and support the vehicle. Failure to use lifting and support devices of rated load capacity may result in severe bodily injury.

9. Remove the tire/wheel assembly. Refer to **Tires and Wheels** section for information on removing the tire and wheel assembly.

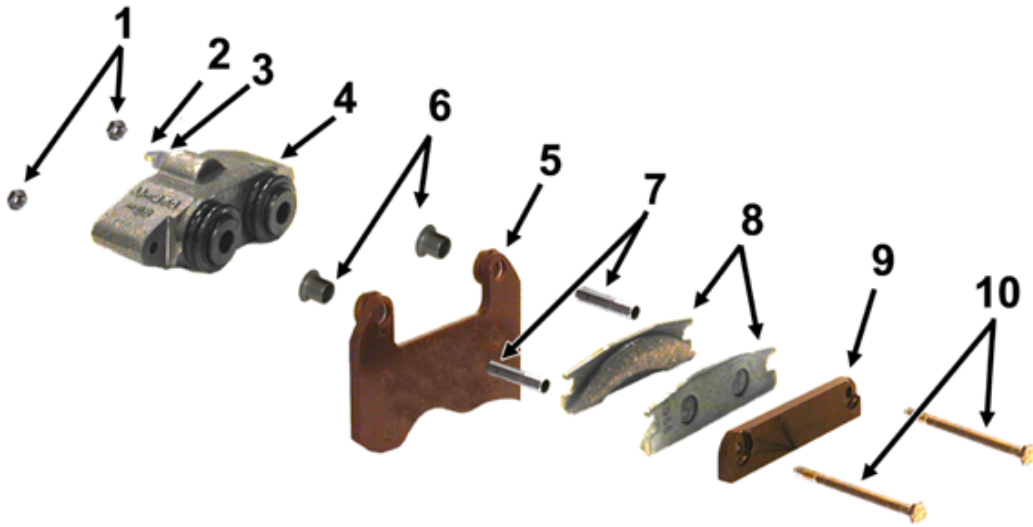

NOTE: Refer to the illustration above for the following steps.

10. Remove the brake body bolts (10) and discard the lock nuts (1) and brake pads (8).
11. Remove the spacer bushings (6) from the mounting bracket (5) and discard the bushings.
12. Inspect the brake rotor. See **Inspect the Service Brakes** section for information regarding inspecting the brake rotor.
13. Inspect the spacers (7) and replace if any wear or damage is found.
14. Install new spacer bushings in the mounting bracket.
15. Install new brake pads in reverse order. Torque the mounting bolts to 11 ft-lbs.
16. Repeat this procedure for the other wheel.
17. Install the tire/wheel assembly and lower the vehicle to the ground.
18. Fill the master cylinder to the proper level. Refer to **Check Master Cylinder Fluid** section for information on the proper master cylinder fluid level.
19. Reconnect the main positive and negative cables at the batteries.
20. Remove the blocks from behind the wheels.
21. Release the park brake and test drive the vehicle.



REPLACE REAR BRAKE PADS

Hydraulic Disc

⚠ WARNING

Current Taylor-Dunn® brakes are asbestos free. However, there is the possibility that the original brakes were replaced with aftermarket parts containing asbestos. Since this possibility exists, all brake parts should be handled as if they contain asbestos. Refer to appendix C for recommended handling precautions.

NOTE: It is recommended that both the left and right brake pads be replaced as a set.

⚠ WARNING

1. Make sure the key-switch is in the "OFF" position, then remove the key.
2. Place the forward-reverse switch in the center "OFF" position.
3. Set the park brake.
4. Place blocks under the front wheels to prevent vehicle movement.
5. Disconnect the main positive and negative cables at the batteries.

NOTE: Installing new brake pads will raise the brake fluid level in the master cylinder.

6. Thoroughly clean the area around the master cylinder cap.
7. Remove fluid from the master cylinder until it is 1/2 full.



Master cylinder is located between the front seats. Dual reservoir shown.

8. Raise the rear of the vehicle and support with jack stands.

⚠ WARNING

Always use a lifting strap, hoist, and jack stands, of adequate capacity to lift and support the vehicle. Failure to use lifting and support devices of rated load capacity may result in severe bodily injury.



9. Remove the tire/wheel assembly.

*NOTE: Refer to **Tires and Wheels** section for information on removing the tire and wheel assembly.*

10. Release the park brake (wheel brake only).
11. Remove the brake body bolts and discard the lock nuts and brake pads.
12. Remove the spacer bushings from the mounting bracket and discard.
13. Inspect the brake rotor. Refer to **Inspect the Service Brake** section for information regarding inspecting the brake rotor.
14. Inspect the spacers and replace if any wear or damage is found.
15. Install new spacer bushings in the mounting bracket.
16. Back off the parking brake adjustment (wheel park brake only).
17. Install new brake pads in reverse order. Torque the mounting bolts to 11 ft-lbs.
18. Repeat this procedure for the other wheel.
19. Install the tire/wheel assembly and lower the vehicle to the ground.
20. Fill the master cylinder to the proper level. Refer to **Check Master Cylinder Fluid** section for information regarding the correct master cylinder fluid level.
21. Adjust the parking brake (wheel park brake only). Refer to **Adjust the Parking Brake** section.
22. Set the park brake.
23. Reconnect the main positive and negative cables at the batteries.
24. Remove the blocks from behind the wheels.
25. Release the park brake and test drive the vehicle.

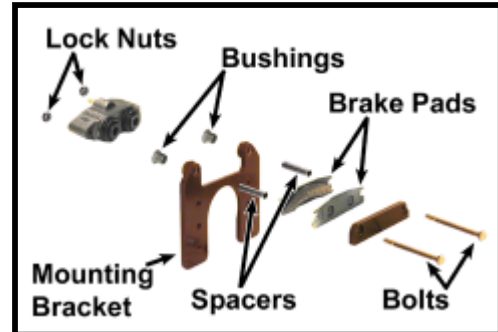

REPLACE THE WHEEL CYLINDER

Disc Brake Body Assembly (front or rear)

⚠ WARNING

Current Taylor-Dunn® brakes are asbestos free. However, there is the possibility that the original brakes were replaced with aftermarket parts containing asbestos. Since this possibility exists, all brake parts should be handled as if they contain asbestos. Refer to appendix C for recommended handling precautions.

⚠ WARNING

Do not ingest brake fluid or allow contact with skin or eyes. Always wear protective clothing and a face shield when working with or around brake fluid.

SKIN CONTACT

Flush area immediately with water for several minutes. If a rash or skin irritation develops, get medical attention immediately.

EYE CONTACT

Immediately flush the eye with water for 15 minutes and call physician.

INGESTION

Get medical attention immediately.

⚠ WARNING

1. Make sure the key-switch is in the "OFF" position, then remove the key.
2. Place the forward-reverse switch in the center "OFF" position.
3. Set the park brake.
4. Place blocks under the wheels to prevent vehicle movement.
5. Disconnect the main positive and negative cables at the batteries.

6. Release the park brake.
7. Raise the wheel off of the ground and support with jack stands.

⚠ WARNING

Always use a lifting strap, hoist, and jack stands, of adequate capacity to lift and support the vehicle. Failure to use lifting and support devices of rated load capacity may result in severe bodily injury.



8. Remove the tire/wheel assembly. Refer to **Tires and Wheels** section for information on removing the tire and wheel assembly.
9. Thoroughly clean the area around the brake body.
10. Remove the brake body bolts and discard the lock nuts.
11. Inspect the brake rotor. Refer to **Inspect the Service Brake** section for information regarding inspecting the brake rotor.
12. Disconnect the brake hose from the brake body.
13. Install the new brake body assembly in reverse order.
 - Use teflon tape thread sealant on the brake hose fitting.
 - Torque the brake body bolts to 11 ft-lbs.
14. Bleed the brakes. Refer to **Bleed the Brakes** section for information regarding bleeding the brakes.
15. Set the park brake.
16. Reconnect the main positive and negative cables at the batteries.
17. Lower the wheel to the ground.
18. Remove the blocks from behind the wheels.
19. Release the park brake and test drive the vehicle.

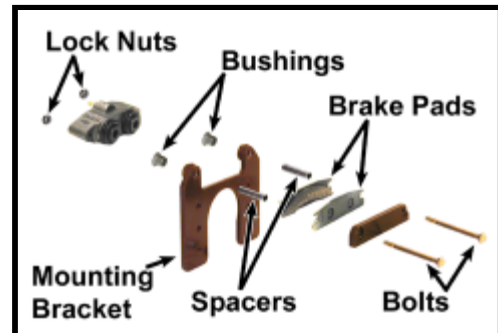

REPAIR THE BRAKE BODY

⚠ WARNING

Hydraulic brake system components must be kept clean. Make sure your work area is free from dirt and debris and will contain any brake fluid spills. Any debris or contaminants left in the brake system could lead to brake failure and result in property damage and/or severe bodily injury.

⚠ WARNING

Do not ingest brake fluid or allow contact with skin or eyes. Always wear protective clothing and a face shield when working with or around brake fluid.

SKIN CONTACT

Flush area immediately with water for several minutes. If a rash or skin irritation develops, get medical attention immediately.

EYE CONTACT

Immediately flush the eye with water for 15 minutes and call physician.

INGESTION

Get medical attention immediately.

⚠ WARNING

1. Make sure the key-switch is in the "OFF" position, then remove the key.
2. Place the forward-reverse switch in the center "OFF" position.
3. Set the park brake.
4. Place blocks under the front wheels to prevent vehicle movement.
5. Disconnect the main positive and negative cables at the batteries.

6. Remove the brake body from the vehicle.

*NOTE: Refer to **Replace the Brake Body Assembly (front or rear)** section for information on removing the brake body.*

7. Pull the pistons out of the brake body.

⚠ WARNING

The pistons are very fragile. If the piston is damaged it must be replaced. Failure to replace a damaged piston could lead to brake failure and result in property damage and/or severe bodily injury.

8. Remove the piston rubber boot.
9. Remove the piston o-ring from inside of the brake body.
10. Inspect and replace parts as required.



Maintenance, Service, and Repair

11. Lubricate the brake parts with clean brake fluid from a sealed container.
12. Install the o-rings into the brake body. Make sure that the o-rings are installed into the second groove and that they are not twisted.

NOTE: There are two different brake assemblies. One has a standard o-ring with a round cross section, the other has a square cross section. The two o-rings are not interchangeable. The square o-ring is not available as a replacement part. If the square o-ring is damaged, the entire brake assembly must be replaced.



13. Using tool #41-350-13, slide the rubber boots onto the pistons as shown. The boot should be hanging off of the end of the piston.



14. Insert the rubber boot/piston into the brake body making sure that the boot is properly seated in the groove.

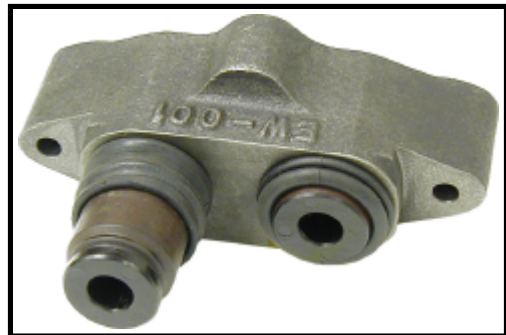

15. Press the pistons all the way down into the brake body making sure that the boot seats properly into the upper groove on the piston.
16. Install any fittings or plugs that were removed from the brake body using teflon tape thread sealant.
17. If the brake body assembly is not to be immediately installed onto a vehicle, plug the brake hose fitting hole to prevent any contaminates from entering the brake body.



REPLACE THE MASTER CYLINDER

⚠ WARNING

Do not ingest brake fluid or allow contact with skin or eyes. Always wear protective clothing and a face shield when working with or around brake fluid.

SKIN CONTACT

Flush area immediately with water for several minutes. If a rash or skin irritation develops, get medical attention immediately.

EYE CONTACT

Immediately flush the eye with water for 15 minutes and call physician.

INGESTION

Get medical attention immediately.

⚠ WARNING

1. Make sure the key-switch is in the "OFF" position, then remove the key.
2. Place the forward-reverse switch in the center "OFF" position.
3. Set the park brake.
4. Place blocks under the rear wheels to prevent vehicle movement.
5. Disconnect the main positive and negative cables at the batteries.

NOTE: Most vehicle configurations do not require lifting the vehicle to remove the master cylinder. Lifting the vehicle may not be required.

6. If required, raise the vehicle and support with jack stands.

⚠ WARNING

Always use a lifting strap, hoist, and jack stands, of adequate capacity to lift and support the vehicle. Failure to use lifting and support devices of rated load capacity may result in severe bodily injury.

7. Place a drain pan under the master cylinder.
8. Disconnect the brake line(s) to the master cylinder and pump out the fluid in the master cylinder by depressing the pedal several times.
9. Remove the master cylinder bolts and remove the master cylinder from the vehicle.



Maintenance, Service, and Repair

10. Install in reverse order.
11. Adjust the master cylinder push rod so that it is approximately 1/8 inch away from the master cylinder plunger when the brake pedal is up.
12. Fill the master cylinder with brake fluid from a sealed container.
13. Pump the brake pedal a short distance of one to two inches until no bubbles are seen coming from the inlet ports inside of the master cylinder chamber.
14. If the vehicle was raised, lower it to the ground.
15. Bleed the brakes. refer to **Bleed the Brakes** section for information regarding bleeding the brakes.
16. Reconnect the main positive and negative cables at the batteries.
17. Remove the blocks from behind the wheels.
18. Release the park brake and test drive the vehicle.

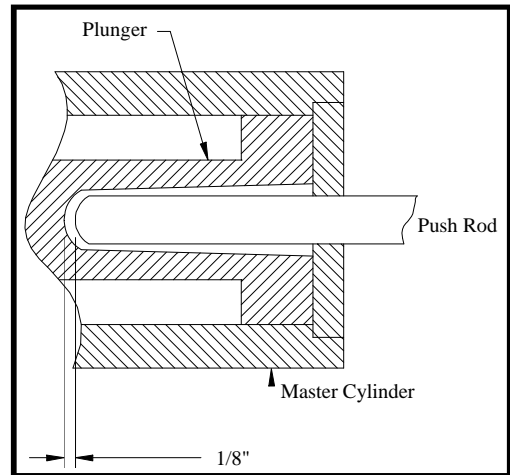

Cutaway of typical master cylinder showing the push rod clearance

⚠ WARNING

- **Only use DOT 3 brake fluid from a new sealed container.**
- **DOT 3 brake fluid is corrosive and will damage paint finishes.**
- **Dispose of brake fluid in accordance with local state and federal regulations.**
- **Read and follow all warnings on the brake fluid container.**



REPAIR THE MASTER CYLINDER

NOTE: Hydraulic brake system components must be kept clean. Make sure your work area is free from dirt and debris and will contain any brake fluid spills.

Remove the master cylinder from the vehicle. See **Replace the Master Cylinder** section .

Drain all fluid from the master cylinder and discard.

Remove the rubber boot.

Depress the plunger and remove the plunger spring clip retainer.

Pull the plunger and all seals out of the master cylinder bore.

Thoroughly clean, inspect and replace parts as required.

If any damage is found in the bore of the master cylinder then it must be replaced.

Lubricate all parts with clean brake fluid from a sealed container.

Reassemble in reverse order.

If the master cylinder is not to be immediately installed onto a vehicle, plug the brake line fitting hole to prevent any contaminants from entering the master cylinder.

TAYLOR - DUNN

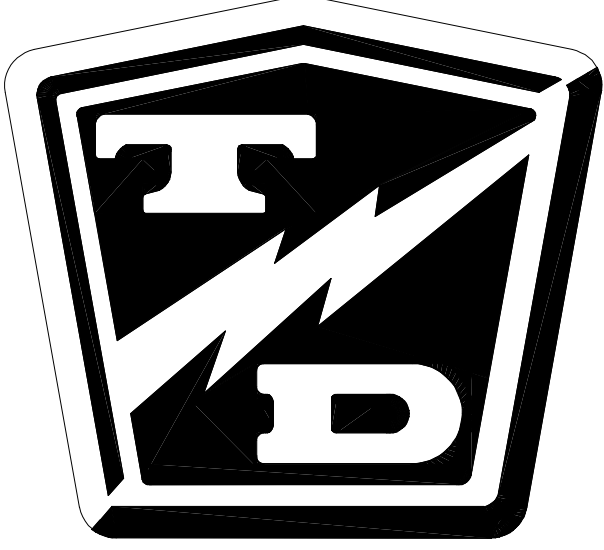

Motor Service

TABLE OF CONTENTS

Inspecting the Motor Brushes	2
Motors with internal cooling fans	2
Motor Removal and Installation	3
Motor Inspection	3
Replacing the Brushes or	
Armature Bearing	7
Repairing the Commutator	8
Service Limits	10

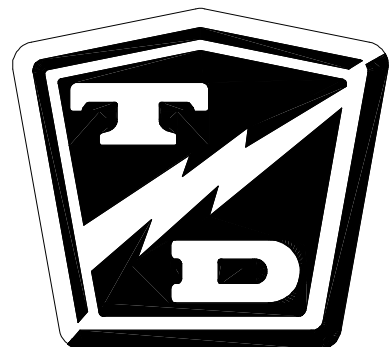



INSPECTING THE MOTOR BRUSHES

Motors with internal cooling fans

NOTE: There are four brushes in the motor. The brushes will not wear at the same rate. It is recommended that all four brushes are inspected at the same time.

*NOTE: In some vehicle configurations it may not be possible to inspect all four brushes while the motor is in the vehicle. Refer to **Transmission Service** section for information on removing the motor.*

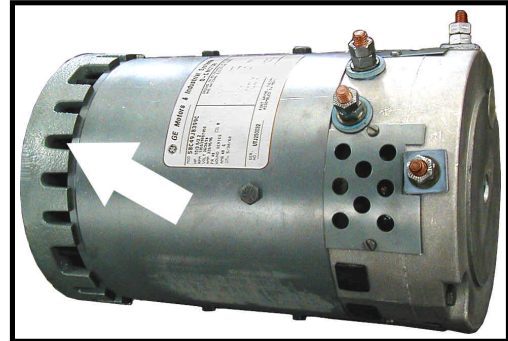

Typical motor with cooling fan indicated by the arrow

⚠ WARNING

- 1. Make sure the key-switch is in the "OFF" position, then remove the key.**
- 2. Place the forward-reverse switch in the center "OFF" position.**
- 3. Set the park brake.**
- 4. Place blocks under the front wheels to prevent vehicle movement.**
- 5. Disconnect the main positive and negative cables at the batteries.**

6. Look through the brush cover and compare the top of the brush to the top of the brush holder. If it is even with or below the top of the brush holder then the brushes should be removed and measured. Refer to **Replacing the Brushes** section for information regarding removing the motor brushes.
7. If any one brush is less than or equal to the service limit specified in **Service Limits**, then all four brushes should be replaced.
8. Reconnect the main positive and negative cables at the batteries.
9. Remove the blocks from behind the wheels, release the park brake and test drive.

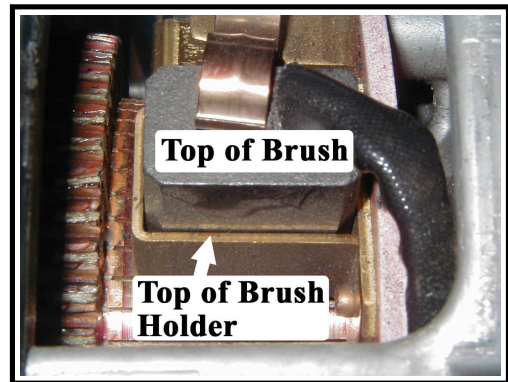

Typical brush and brush holder

MOTOR REMOVAL AND INSTALLATION

See the **Transmission** section for information on removing or installing the motor.

MOTOR INSPECTION

Disassembly

1. Remove the motor from the vehicle. See the **Transmission** section for information on removing the motor.
2. Remove the brush cover and pull the brushes out away from the commutator.
3. Remove the dust cap from the rear motor housing.
4. Place the motor in a press, and press the armature out of the rear bearing.

NOTE: Removing the armature will damage the motor bearing. The motor bearing should be replaced whenever the armature is removed.
5. Remove the housing screws from the rear motor housing and remove the housing from the motor.
6. Remove the nuts from the armature studs and remove the two brush assemblies.
7. Remove the bearing circlip and press the motor bearing out of the housing and discard.

Inspection

1. Measure the length of each motor brush.
 - If any one brush is less than or equal to the service limit specified in section **Service Limits**, then all four brushes should be replaced. Refer to **Replacing the Brushes** section for information regarding replacing the motor brushes.

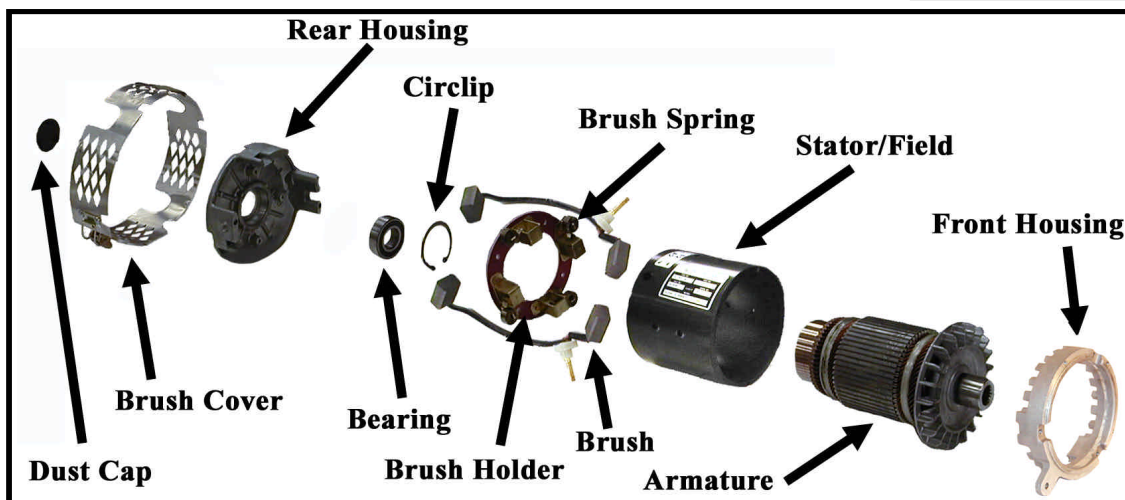
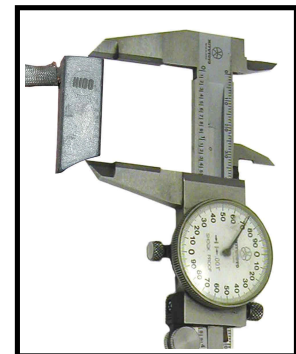



2. Measure the diameter of the commutator.
 - If the commutator is less than the minimum diameter specified in section **Service Limits**, then the motor must be replaced.

3. Measure the commutator undercut depth in 5-places around the commutator.
 - If any one of the measurements is less than the minimum undercut depth specified in **Service Limits** at the end of this section, then the commutator must be undercut. Refer to **Repair Commutator** section for information regarding undercutting the commutator.
4. Inspect the commutator for groves.
 - If the commutator is grooved then it must be machined on a lathe. Do not machine the commutator past the minimum diameter specified in **Service Limits** section. Refer to **Repair Commutator** section for information regarding machining the commutator.
5. Inspect the commutator for burn marks.
 - Burn marks and/or raised commutator segments 90 or 180 degrees apart is evidence of a shorted armature. A tool called a growler is required to reliably test for a shorted armature.
6. Inspect the commutator for raised segments. Raised segments could be a result of a stalled motor or shorted armature. A tool called a growler is required to reliably test for a shorted armature.
 - If the armature is not shorted then the raised segments can be removed by machining the commutator. Do not machine the commutator past the minimum diameter specified in **Service Limits** section. Refer to **Repair Commutator** section for information regarding machining the commutator.

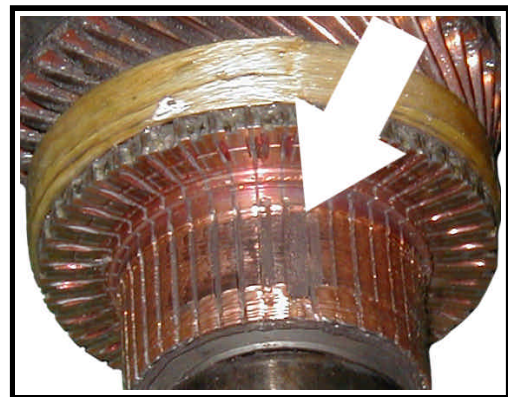
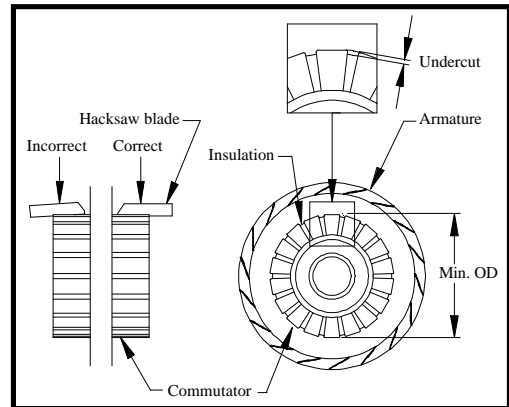

Typical burn mark on a shorted armature

7. Visually inspect the armature windings for burnt insulation. Burnt insulation is a direct result of motor overheating and could lead to a shorted armature.
 - If the insulation is cracked or burnt, then it is recommend that the armature or motor be replaced.

NOTE: If the armature has been burnt then there is a good possibility that the field windings may also be burnt. Symptoms indicating a shorted field include high motor current, lack of power and possibly excessive speed.

8. Using a growler, test the armature for shorts.
 - If the armature is shorted, then we recommend that the armature or motor be replaced.

9. Using the continuity function of digital multi meter, check the continuity around the entire commutator by placing one test lead against one of the commutator segments and the other test lead against all of the other segments one at a time. There should be continuity around the entire commutator. If any segment indicates an open circuit, then the motor must be replaced.

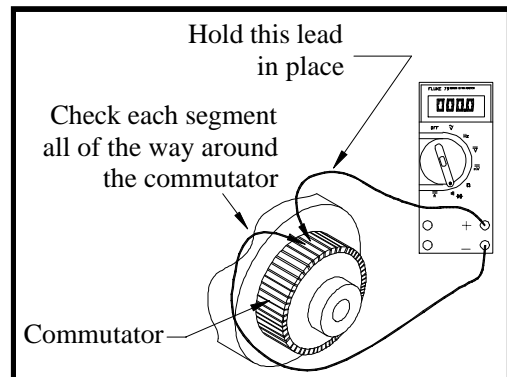

10. Using the continuity function of digital multi meter, check the continuity from any one of the commutator segments and the armature frame. If it is not an open circuit, then the armature is shorted and the motor must be replaced.

11. Measure the armature and field resistance (refer to **Service Limits** table at end of this section). If the armature or field resistance is not within specification then the motor must be repaired or replaced.

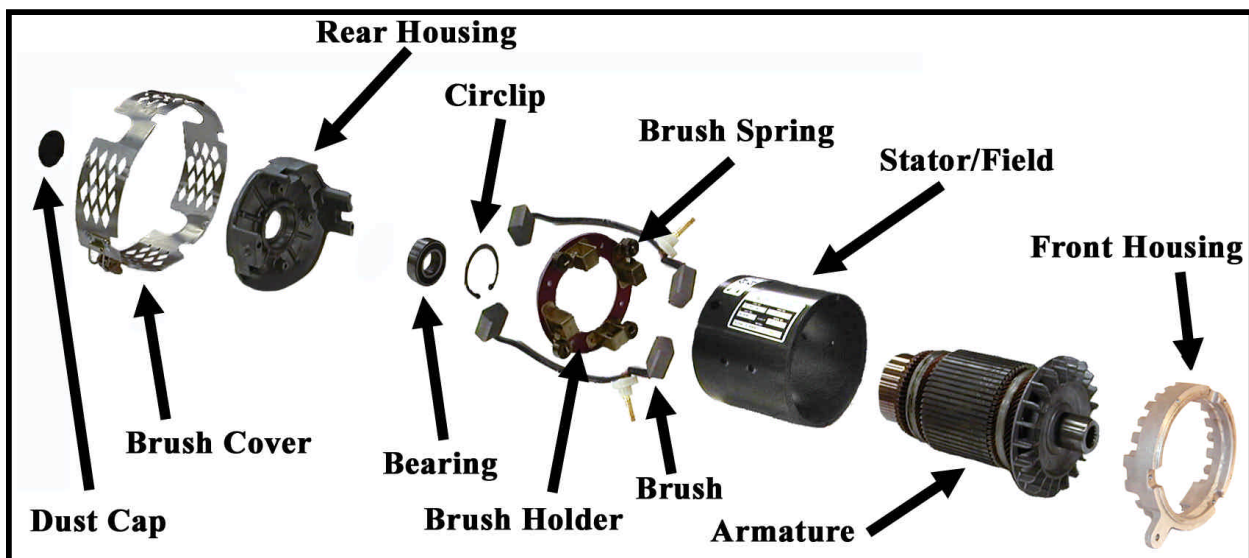



Assembly

1. Press a new bearing into the motor housing and install the circlip.
2. Install the two brush assemblies so that the brushes are just far enough out of the brush holder so that the brush springs hold them in place away from the commutator. See the illustration to the right.
3. Install the rear motor housing to the stator housing.
4. Lightly grease the inside diameter of the armature bearing.
5. Carefully insert the armature through the stator housing and onto the motor bearing in the rear housing.
6. While supporting the inner race of the bearing, press the armature into the bearing.
7. Push the motor brushes into the brush holder until the brush spring snaps into place. Be certain that the spring does not rest up against the brush wire. See the illustrations below.
8. Install the brush cover.

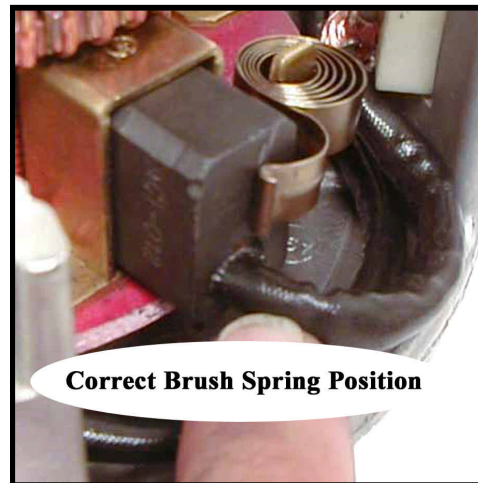

REPLACING THE BRUSHES OR ARMATURE BEARING

NOTE: It is recommended that all four brushes be replaced as a set.

*NOTE: The motor must be disassembled to replace the brushes or the bearing. Refer to **Motor Inspection-Disassembly** section for information on taking the motor apart.*

*NOTE: The motor must be removed from the vehicle for this procedure. Refer to **Transmission Service** section for information on removing the motor.*





REPAIRING THE COMMUTATOR

1. The motor must be removed from the vehicle for this procedure. Refer to **Transmission Service** section for information on removing the motor.
2. The armature must be removed from the motor for this procedure. Refer to **Motor Inspection-Disassembly** section for information on taking the motor apart.
3. Using a lathe, cut the armature just enough to remove all grooves, depressions or ridges.

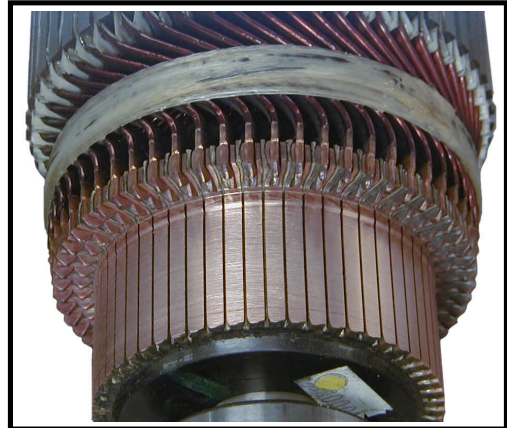

Example of freshly cut commutator

4. Measure the diameter of the commutator. If the commutator is less than the minimum diameter specified in **Service Limits**, then the motor must be replaced.

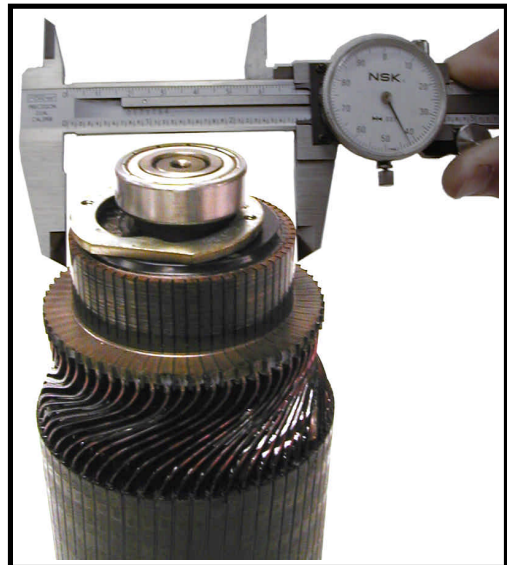

5. Thoroughly clean all copper debris from between the commutator segments.
6. Measure the commutator undercut depth in 5-places around the commutator. If any one of the measurements is less than the minimum undercut depth specified in **Service Limits**, then the commutator must be undercut.
7. While still in the lathe, smooth the commutator with fine emery cloth.

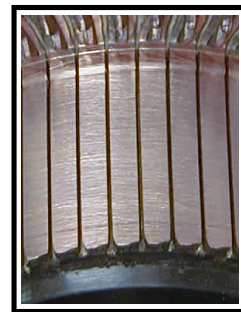

Properly undercut and cleaned commutator segments

Undercutting the commutator

1. Using a small straight cut saw blade, cut the commutator insulation to the proper depth. Refer to undercut depth in **Service Limits**.
2. Once all segments have been properly undercut, mount the armature in a lathe and smooth the commutator with fine emery cloth.

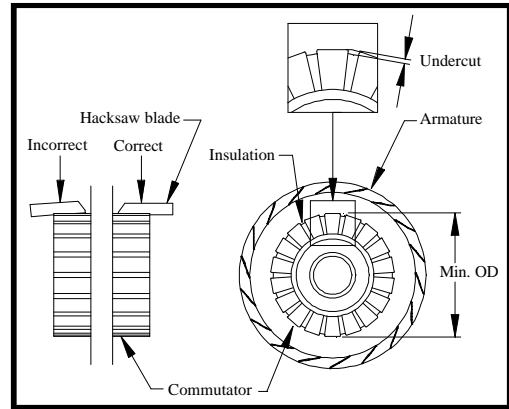

3. Inspect the armature for shorts. Refer to **Motor Inspection** section for information on testing the armature.

NOTE: Copper debris in the undercut area can give a reading of a shorted armature.

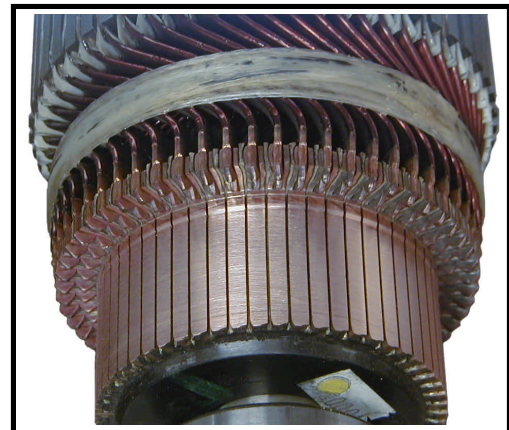

Example of freshly cut commutator



SERVICE LIMITS

Motor Specification Number	Undercut Depth		Commutator Diameter (min)		Brush Length (min)		Resistance (Ohms@75° F)	
	mm	inches	mm	inches	mm	inches	Armature	Field
70-054-40 (XP-1672 or DV1-4002)	0.635	0.025	69.85	2.75	15.87	0.625	.0116	1.20
70-054-41 (XP-1789 or DY2-4001)	0.635	0.025	69.85	2.75	15.87	0.625	0.011	0.43
70-057-40 (XP-1673 or DV1-4003)	0.635	0.025	69.85	2.75	15.87	0.625	0.008	0.58
70-052-40 (XP 1876 or DD3-4004)	0.635	0.025	69.85	2.75	15.87	0.625	0.011	0.73

Transmission

TABLE OF CONTENTS

Check Oil Level	2
Change Oil	3
Motor Removal and Installation	4
Rear Hub or Rotor	5
Removing and Installing the Rear Axles (Disc Brakes)	6
Transmission Assembly	8
Remove and Install	8
Disassembly and Reassembly of the Primary Reduction Gear Case	9
Disassembling the 3rd Member	12
Assembling the 3rd Member	15
Pinion Bearing Preload	18
Pinion Gear Shimming Instructions	19
Setting the Pinion Gear Depth	19

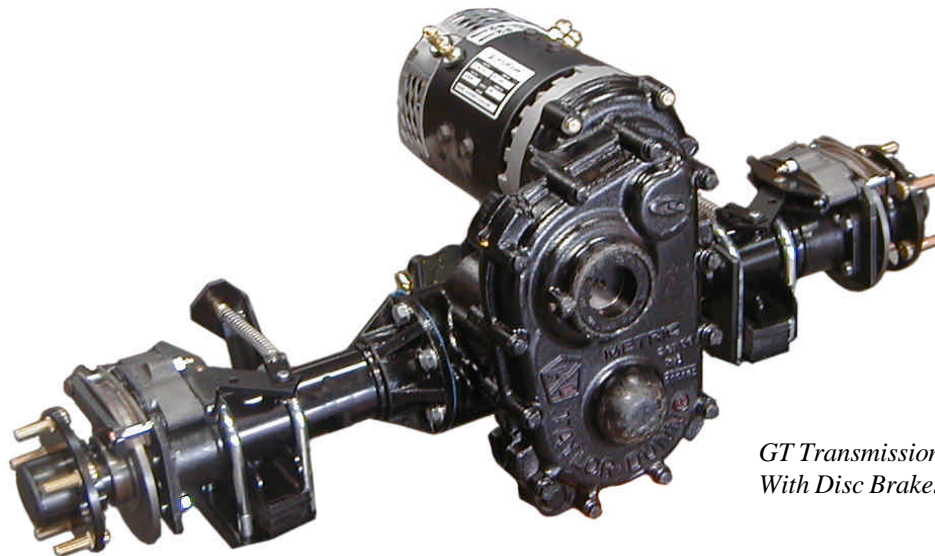

*GT Transmission Assembly
With Disc Brakes*



CHECK OIL LEVEL

The oil flows freely between the main gear case (3rd member) and the primary reduction gear case. It is only necessary to check the oil level of the 3rd member.

Park the vehicle on a level surface.

⚠ WARNING

- 1. Make sure the key-switch is in the "OFF" position, then remove the key.**
- 2. Place the forward-reverse switch in the center "OFF" position.**
- 3. Set the park brake.**
- 4. Place blocks under the front wheels to prevent vehicle movement.**
- 5. Disconnect the main positive and negative cables at the batteries.**

6. Place a level on the top of the motor. Raise the rear of the vehicle until the level indicates that the drive is level with the ground.
7. Place an oil drain pan underneath the 3rd member.
8. Remove the fill/level plug.
9. The oil level should be very close to the bottom of the level plug opening.
 - a. If the oil level is below the bottom of the opening, add oil as required until level with the bottom of the opening. Refer to the **Lube Chart** section for information regarding type of oil.
 - b. If oil comes out of the opening, allow to drain until level with the bottom of the opening.
10. Replace the fill/level plug.
11. Reconnect the main positive and negative cables at the batteries.
12. Remove the blocks from the wheels.
13. Release the park brake and test drive the vehicle.

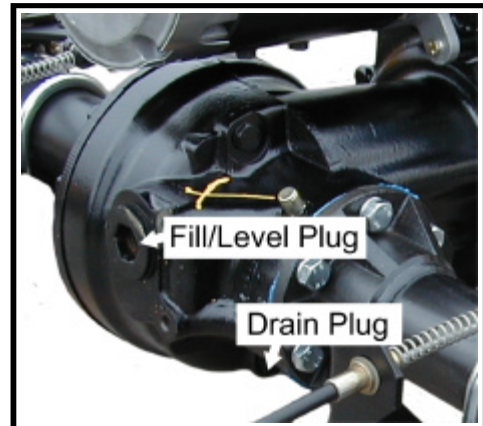

CHANGE OIL

WARNING

1. Make sure the key-switch is in the "OFF" position, then remove the key.
2. Place the forward-reverse switch in the center "OFF" position.
3. Set the park brake.
4. Place blocks under the front wheels to prevent vehicle movement.
5. Disconnect the main positive and negative cables at the batteries.

6. Raise the rear of the vehicle and support with jack stands.
7. Place a four quart drain pan under the drive assembly.
8. Remove the drain plugs from the differential case and gear case.
9. Once the oil has drained, replace the drain plugs and lower the vehicle to the ground.
10. Remove the fill/level plug and fill the differential up to the bottom of the level plug opening. Refer to the **Lube Chart** section for information regarding type of oil.
11. Replace the fill plug.
12. Reconnect the main positive and negative cables at the batteries.
13. Remove the blocks from the wheels.
14. Release the park brake and test drive the vehicle.

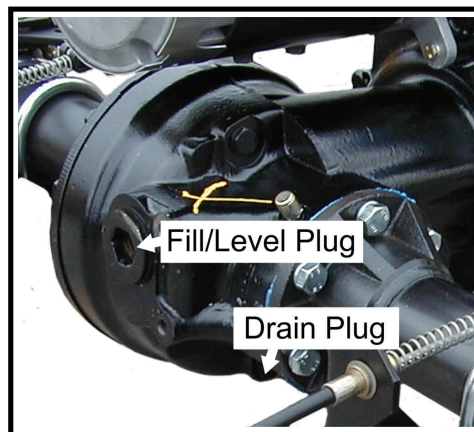



MOTOR REMOVAL AND INSTALLATION

*NOTE: Some applications will require removing the drive assembly from the vehicle to remove the motor. Refer to **Removing and Installing the Drive Assembly** for information on removing the drive assembly.*

Some vehicles are equipped with an automatic electric brake. The automatic electric brake is sandwiched between the drive motor and the gear case. The electric brake is retained by the drive motor mounting screws. Once the motor is removed the electric brake will no longer be retained by any hardware.

⚠ WARNING

- 1. Make sure the key-switch is in the "OFF" position, then remove the key.**
- 2. Place the forward-reverse switch in the center "OFF" position.**
- 3. Set the park brake.**
- 4. Place blocks under the front wheels to prevent vehicle movement.**
- 5. Disconnect the main positive and negative cables at the batteries.**

6. Remove the wires from the motor.

NOTE: Label the motor wires with the number of the motor terminal before they are removed from the motor.

7. If equipped, remove the motor support bracket u-bolt (only used on larger motors).
8. Remove the motor mounting bolts and slide the motor off of the input shaft.
9. Install the motor in reverse order.

NOTE: Apply a light coating of 94-421-34 grease to the splines on the transmission input shaft only.

10. Reconnect the main positive and negative cables at the batteries.
11. Remove the blocks from behind the wheels.
12. Release the park brake and test drive the vehicle.



Support bracket u-bolt

REAR HUB OR ROTOR

NOTE: The torque specification for the axle hub bolt is 275 ft-lbs. An impact wrench will be required to remove the bolt.

NOTE: The axle hub bolt has a special thread locking compound applied to the threads. If this bolt is removed, it must be replaced.

⚠ WARNING

1. Make sure the key-switch is in the "OFF" position, then remove the key.
2. Place the forward-reverse switch in the center "OFF" position.
3. Set the park brake.
4. Place blocks under the front wheels to prevent vehicle movement.
5. Disconnect the main positive and negative cables at the batteries.

6. Raise the wheel off of the ground.

⚠ WARNING

Always use a lifting strap, hoist, and jack stands, of adequate capacity to lift and support the vehicle. Failure to use lifting and support devices of rated load capacity may result in severe bodily injury.

7. Remove the tire/wheel assembly, Refer to *Tires and Wheels* section for information regarding removing the tire/wheel assembly.
8. Remove the axle hub bolt and washer and remove the hub from the axle.
9. Remove the outer brake pad. Refer to section *Brake Service* for information regarding removing the brake pads.
10. Remove the rotor.
11. Install in reverse order.



- a. Lightly grease the axle splines.
- b. Refer to section *Brake Service* for information regarding installing the brake pads.
- c. Thoroughly clean the threads in the axle shaft.
- d. Using a new bolt, torque the axle hub bolt to 275 ft-lbs.

⚠ WARNING

If the axle bolt is removed, it must be replaced with a new bolt. Failure to use a new bolt may result in the wheel coming off of the vehicle and loss of brakes, causing severe bodily injury and/or property damage.

- e. Refer to *Tires and Wheels* section for information regarding installing the tire/wheel assembly.
12. Lower the wheel to the ground.
10. Reconnect the main positive and negative cables at the batteries.
11. Remove the blocks from behind the wheels, release the park brake and test drive the vehicle.



REMOVING AND INSTALLING THE REAR AXLES (DISC BRAKES)

The oil level in the housing is above the bottom of the axle flange. To minimize oil spills, raise the side of the vehicle high enough so that the oil level is below the bottom of the axle flange. If both axles are to be removed, you must drain all of the oil from the housing.

NOTE: This procedure does not require that the rear end or drive assembly be removed from the vehicle.

NOTE: The axle hub bolt has a special thread locking compound applied to the threads. If this bolt is removed, it must be replaced.

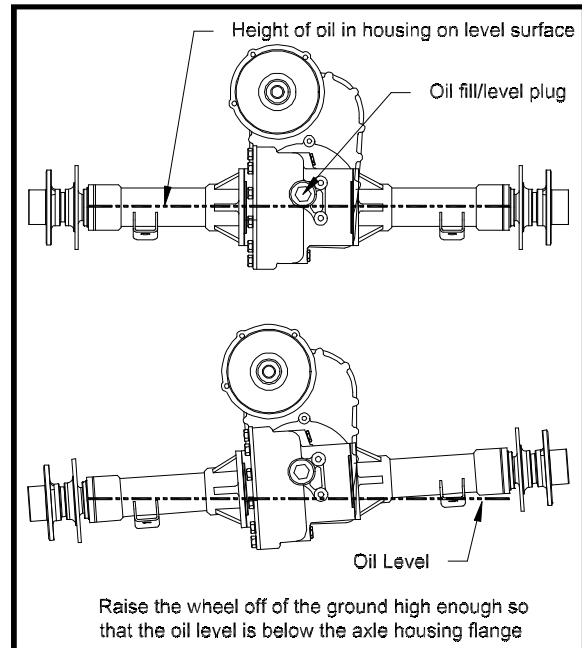

⚠ WARNING

1. Make sure the key-switch is in the "OFF" position, then remove the key.
2. Place the forward-reverse switch in the center "OFF" position.
3. Set the park brake.
4. Place blocks under the front wheels to prevent vehicle movement.
5. Disconnect the main positive and negative cables at the batteries.

6. If required, drain the oil from the 3rd member.
7. Raise the rear of the vehicle and support with jack stands.

⚠ WARNING

Always use a lifting strap, hoist, and jack stands, of adequate capacity to lift and support the vehicle. Failure to use lifting and support devices of rated load capacity may result in severe bodily injury.

8. Release the park brake.
9. Remove the tire and wheel assembly. Refer to section **Tires and Wheels** for information regarding removing the tire and wheel assembly.
 - a. If the axle shaft, hub or bearing is to be replaced then remove the hub bolt, wheel hub and disc rotor at this time.
10. Remove the four bolts attached to the axle retaining plate.

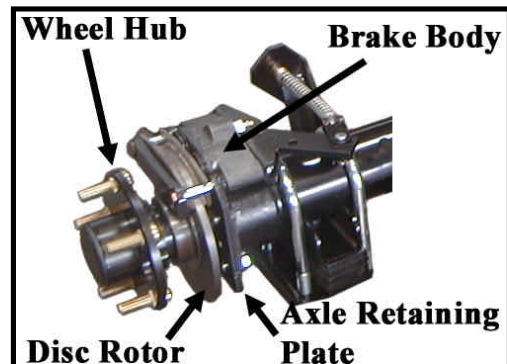

11. Remove the axle retaining plate and brake body assembly as one unit.
12. Secure the brake body assembly, do not let it hang by the brake hose.
13. Pull the axle out of the housing.
14. Inspect all bearings for roughness or play, replace as needed.
15. Install in reverse order, lubricate the o-ring.

NOTE: Be sure not to damage the o-ring.

16. Use new bolts for the axle retaining plate.

WARNING

The axle retaining plate bolts have a pre-applied thread locking compound. They are intended for one time use only. If removed they must be replaced. Reusing the original bolts could cause loss of brakes resulting in severe bodily injury and/or property damage.

Refer to section Rear Brakes in Illustrated Parts for the part number of the bolt.

17. If the wheel hub was removed, install the hub and rotor. Torque the hub bolt to 275 ft-lbs.
17. Fill with oil to the level of the fill plug threads. Refer to ***Changing the Differential Oil.***
18. Lower the vehicle.
19. Set the park brake.
20. Reconnect the main positive and negative cables at the batteries.
21. Remove the blocks from behind the wheels.
22. Release the park brake and test drive the vehicle.





TRANSMISSION ASSEMBLY

Remove and Install

⚠ WARNING

1. Make sure the key-switch is in the "OFF" position, then remove the key.
2. Place the forward-reverse switch in the center "OFF" position.
3. Set the park brake.
4. Place blocks under the front wheels to prevent vehicle movement.
5. Disconnect the main positive and negative cables at the batteries.

6. Release the park brake.
7. Remove the park brake cables from the spring axle mounting brackets and brake arms.
8. Disconnect the wiring from the motor.
9. Disconnect the hydraulic brake lines from the left and right brake bodies.

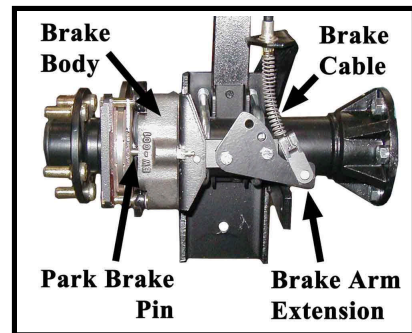

10. Remove the u-bolts holding the leaf springs to the frame as shown in the illustration to the right. Do not remove the u-bolts on the axle housing.
11. Remove the lower shock mounting bolts and the front spring mounting bolts.
12. Raise the rear of the vehicle, lifting the frame up and off of the drive assembly. Support the rear of the vehicle with jack stands.

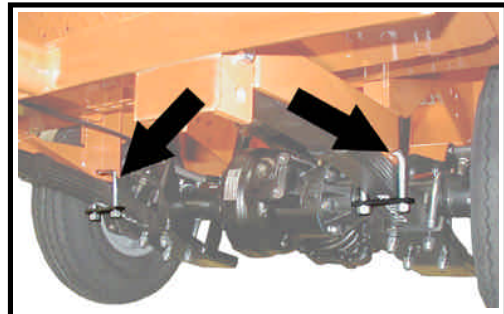

⚠ WARNING

Always use a lifting strap, hoist, and jack stands, of adequate capacity to lift and support the vehicle. Failure to use lifting and support devices of rated load capacity may result in severe bodily injury.

13. Reinstall the drive in reverse order.
14. Bleed the brake system. Refer to ***Bleed the Brake System*** for information regarding bleeding the brakes.
15. Set the park brake.
16. Lower the vehicle.
17. Reconnect the main positive and negative cables at the batteries.
18. Remove the blocks from the wheels, release the park brake and test drive the vehicle.

DISASSEMBLY AND REASSEMBLY OF THE PRIMARY REDUCTION GEAR CASE

⚠ WARNING

1. Make sure the key-switch is in the "OFF" position, then remove the key.
2. Place the forward-reverse switch in the center "OFF" position.
3. Set the park brake.
4. Place blocks under the front wheels to prevent vehicle movement.
5. Disconnect the main positive and negative cables at the batteries.

6. Raise the rear of the vehicle and support with jack stands.

⚠ WARNING

Always use a lifting strap, hoist, and jack stands, of adequate capacity to lift and support the vehicle. Failure to use lifting and support devices of rated load capacity may result in severe bodily injury.

7. Place a drain pan under the gear case that is capable of holding four quarts of oil and drain the oil from the front gear case.
8. If required, remove the drive assembly from the vehicle

*NOTE: Refer to **Removing and Installing the Drive Assembly** for information on removing the drive from the vehicle.*

9. Remove the motor only if the entire drive is to be disassembled.

*NOTE: Refer to **Motor Removal and Installation** for information on removing the motor.*

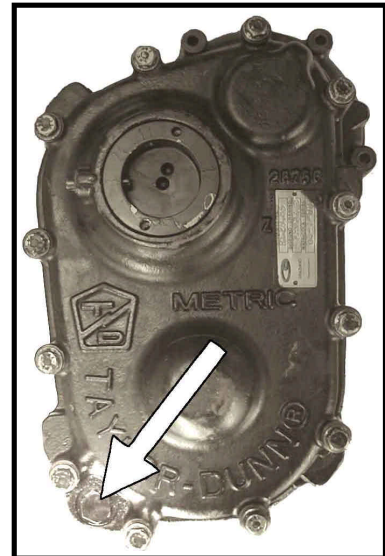

Oil Drain Plug

10. Remove the cover retaining bolts.
11. Remove the cover plate from the differential and let the remaining oil drain from the housing.

⚠ CAUTION

Be careful not to damage the sealing surfaces on the housings. Damage to the sealing surface may lead to an oil leak resulting in damage to the internal parts of the drive.

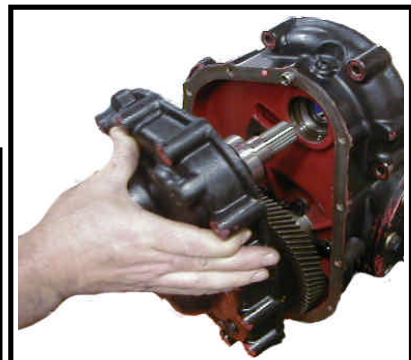



Maintenance, Service, and Repair

12. Remove the circlip from the idler gear.



13. Remove the input shaft/bearing assembly and idler gear/bearing assembly from the gear case cover at the same time.



14. Remove the pinion nut from the output gear and remove the output gear from the pinion shaft.

NOTE: If necessary, remove the seal from the input shaft bore at this time.



15. Mark the gear case position in relation to the 3rd member housing so that it will be reassembled in the same position.
16. Remove the six retaining bolts holding the gear case to the 3rd member housing.

NOTE: Make note of the angle of the gear case.

17. Remove the gear case housing from the 3rd member housing.
18. Inspect all parts for signs of wear or damage.

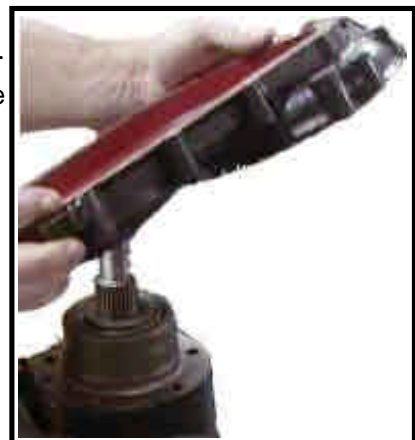

⚠ CAUTION

Lubricate all parts with gear oil before installation. Failure to pre-lube the parts may result in premature failure.

19. Assemble the gear case in reverse order.

NOTE: Torque the drain plug to 21-25 foot-pounds.

NOTE: Torque the gear case to 3rd member retaining bolts to 18-20 foot-pounds.

NOTE: Torque the pinion nut to 154-169 foot-pounds.

NOTE: Apply gasket sealer (#94-430-05) to the front flange on the 3rd member and gear case cover.

NOTE: Pack the motor seal with non-acetic based grease.

20. Fill the differential with oil.

*NOTE: Refer to **Changing the Differential Oil** for information on filling the drive with oil.*

21. Lower the vehicle.

22. Reconnect the main positive and negative cables at the batteries.

23. Remove the blocks from behind the wheels.

24. Test drive the vehicle.





DISASSEMBLING THE 3RD MEMBER

⚠ WARNING

1. Make sure the key-switch is in the "OFF" position, then remove the key.
2. Place the forward-reverse switch in the center "OFF" position.
3. Set the park brake.
4. Place blocks under the front wheels to prevent vehicle movement.
5. Disconnect the main positive and negative cables at the batteries.

6. Raise the rear of the vehicle and support with jack stands.

⚠ WARNING

Always use a lifting strap, hoist, and jack stands, of adequate capacity to lift and support the vehicle. Failure to use lifting and support devices of rated load capacity may result in severe bodily injury.

7. Remove the complete drive from the vehicle.

*NOTE: Refer to **Removing and Installing the Drive Assembly** for information on removing the drive from the vehicle.*

8. Place a drain pan under the gear case that is capable of holding four quarts of oil and drain the oil from the front gear case and 3rd member.
9. Place the 3rd member on an appropriate stand.
10. Remove the axle shafts and tubes as an assembly from the 3rd member by removing the six axle tube flange bolts on each axle tube.
11. Remove the primary reduction gear case. Refer to **Disassembly and reassembly of the Primary Reduction Gear Case** for information on removing the gear case.

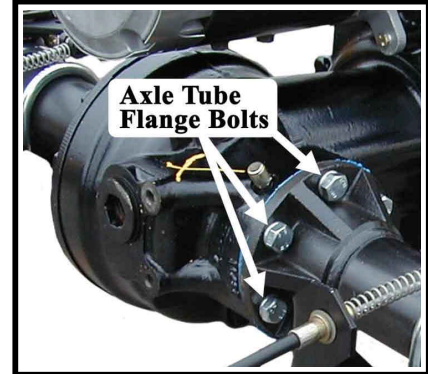

12. Remove the 12 side plate bolts, then remove the side plate.



13. Remove the carrier bearing adjusting nut roll pin and adjusting nut from the side plate.

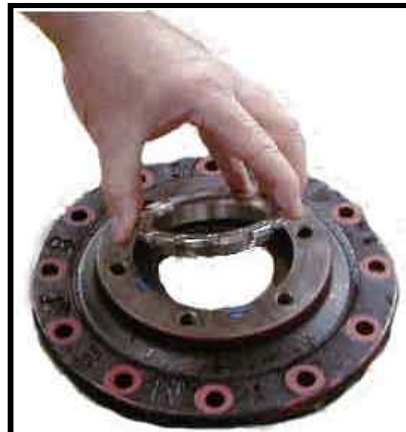

14. Turn the side plate over and remove the carrier bearing race from the side plate.



15. Remove the differential assembly from the 3rd member housing.



16. Remove the carrier bearing adjusting nut roll pin from the 3rd member housing, then remove the carrier adjusting nut.



Roll Pin





Maintenance, Service, and Repair

17. Remove the carrier bearing race from the 3rd member housing.

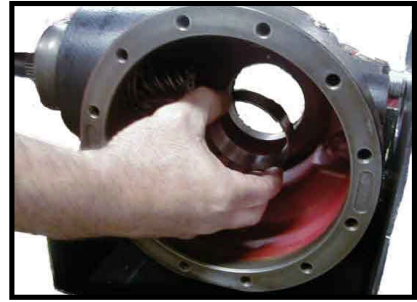

18. Remove the front bearing from the input shaft.

NOTE: The input shaft may have to be driven out to perform this procedure.



19. Remove the input shaft's shims and spacer.



20. Remove the pinion shaft from the 3rd member.
21. Remove the front and rear pinion bearing races.
22. Inspect all parts for signs of wear or damage.
23. Thoroughly clean all parts.



ASSEMBLING THE 3RD MEMBER

1. Temporarily install the pinion gear (hand tighten only).
2. Install the carrier bearing race ring nuts into the housing and cover.

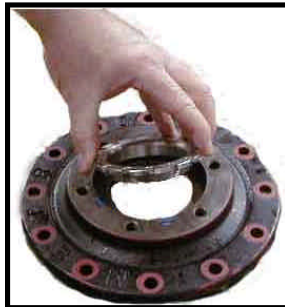

Cover



Housing

3. Install the carrier bearing races into the housing and cover.



Cover

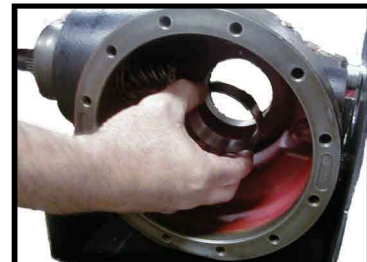

Housing

4. Place the differential assembly into the housing.
5. Tighten the housing carrier bearing race ring nut so that the ring gear is not in binding against the pinion gear.
6. Remove the differential assembly.

NOTE: Do not allow the ring nut to rotate.
7. Remove the pinion gear and then reinstall the differential assembly.
8. Install the cover onto the housing using 4-bolts in a cross pattern and torque to 45-50 ft-lbs.



9. Pre set the carrier bearing preload by tightening the housing carrier bearing race ring nut until it requires 1.5 to 3.3 ft-lbs to rotate the differential assembly.

NOTE: Rotate the carrier assembly whenever adjusting the ring nuts.





Maintenance, Service, and Repair

10. Mark the position of each carrier bearing ring nut in relation to the drive housing and cover and then remove the differential assembly, do not allow the ring nuts to rotate.
11. Install the pinion gear. Re-shim if required.

⚠ CAUTION

If the ring and pinion gears or bearings are replaced then the pinion gear must be re-shimmed. Improper pinion gear shims will result in drive noise and premature failure. Refer to Pinion Gear Shimming Instructions.

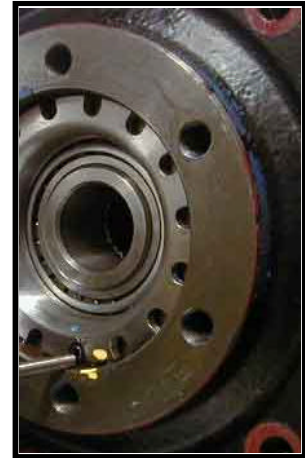

12. Install the pinion gear holding tool (96-500-42) and tighten the pinion nut enough to keep the pinion gear from rotating.
13. Install the differential assembly.
14. Install the cover and all of the cover bolts. Torque to 45-50 ft-lbs.

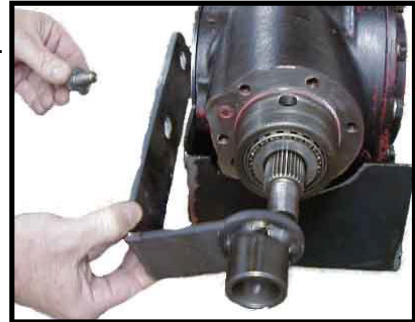

15. Check the gear lash between the ring and pinion gears. The gear lash should be 0.005 to 0.007 inches.
16. Adjust the gear lash if needed by tightening or loosening the carrier bearing race ring nuts. The two ring nuts must be turned equally in opposite directions.



NOTE: To move the ring gear closer to the pinion: Loosen the housing carrier bearing race ring nuts and tighten the cover carrier bearing race ring nut equally.

NOTE: To move the ring gear away from the pinion: Loosen the cover carrier bearing race ring nut and tighten the housing carrier race ring nut equally.

⚠ CAUTION

The two ring nuts must be turned the same amount in opposite directions. This allows the carrier assembly to be positioned with the proper gear lash without upsetting the bearing preload. If the ring nuts are not turned the same amount, then the bearing preload will no longer be correct and will result in drive noise and premature failure.

17. Install the locking roll pins into the housing and cover to lock the ring nuts in place.
18. Remove the pinion gear holding tool.
19. Install the primary reduction gear case, axles and housings, motor, and install the complete drive onto the vehicle.
20. Fill the drive with oil. Refer to the **Lube Chart** section for information regarding type of oil. Refer to **Change Oil** section for information regarding the proper oil level..
21. Lower the vehicle.
22. Reconnect the main positive and negative cables at the batteries.
23. Remove the blocks from behind the wheels.
24. Test drive the vehicle.





Pinion Bearing Preload

*NOTE: The pinion gear depth must be set before the preload. Refer to **Setting the Pinion Gear Depth.***

1. Install the pinion gear, spacer, and shims into the housing.
2. Install the outer pinion bearing.
3. Install the main gear onto the pinion shaft and torque the pinion nut to 154-169 ft lbs.
4. Measure the torque required to rotate the pinion shaft in the housing.
5. The torque required to rotate the pinion shaft should be between 1.1 and 2.9 ft-lbs. If the torque is not within specifications then add or subtract from the total shim thickness and repeat this procedure until the proper preload is obtained.

NOTE: Add shims to decrease torque.

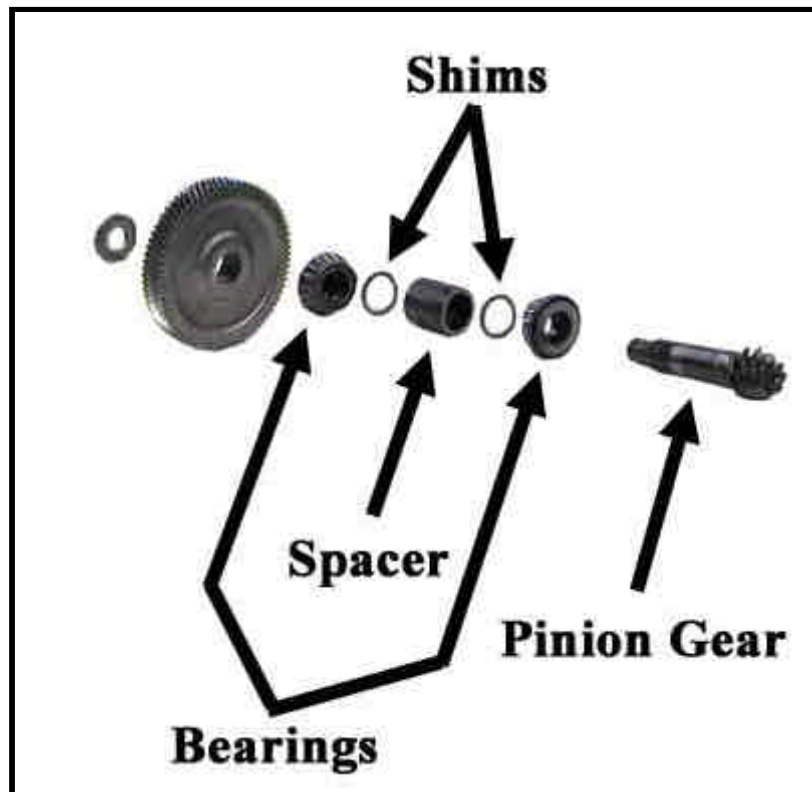

PINION GEAR SHIMMING INSTRUCTIONS

NOTE: This procedure is required only when replacing the front or rear pinion bearings and races or the ring and pinion gears.

NOTE: To perform this procedure, all parts must be clean and the bearings lightly lubricated.

Setting the Pinion Gear Depth

This formula is used to calculate the amount of shims that are required:

C - B - A + (DV) = Pinion Shim (mm) where,

DV = The number on the face of the pinion gear.

A = The distance in millimeters from the face of the pinion gear to the top of the inner pinion bearing race (see below)

B = 54.

C = The number on the edge of the differential side plate closest to the input shaft (see next page).

D = The number on the edge of the differential side plate farthest from the input shaft (see next page).

E = The distance in millimeters from the rear of the drive housing to the face of the pinion gear (see next page).

Once a shim has been selected and the pinion gear is installed, confirm that: **E - D = B + (DV)**



Face of pinion gear

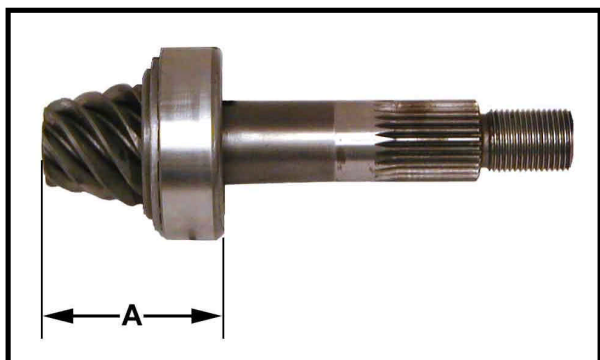

Number on face of pinion gear

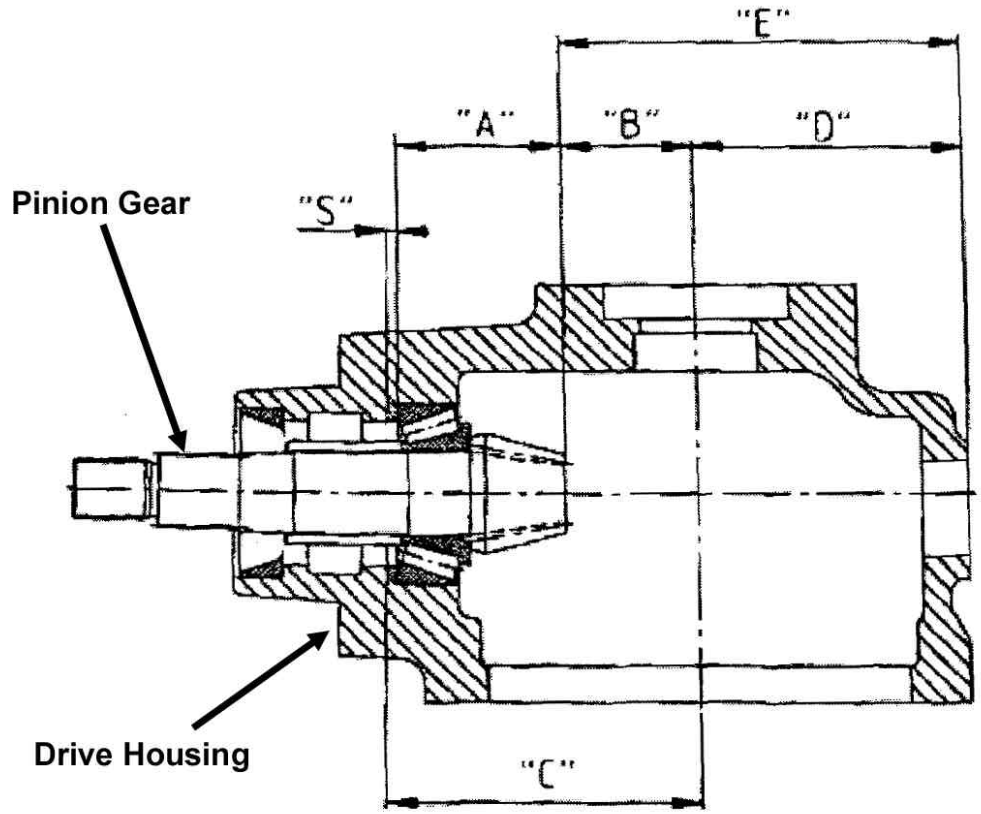
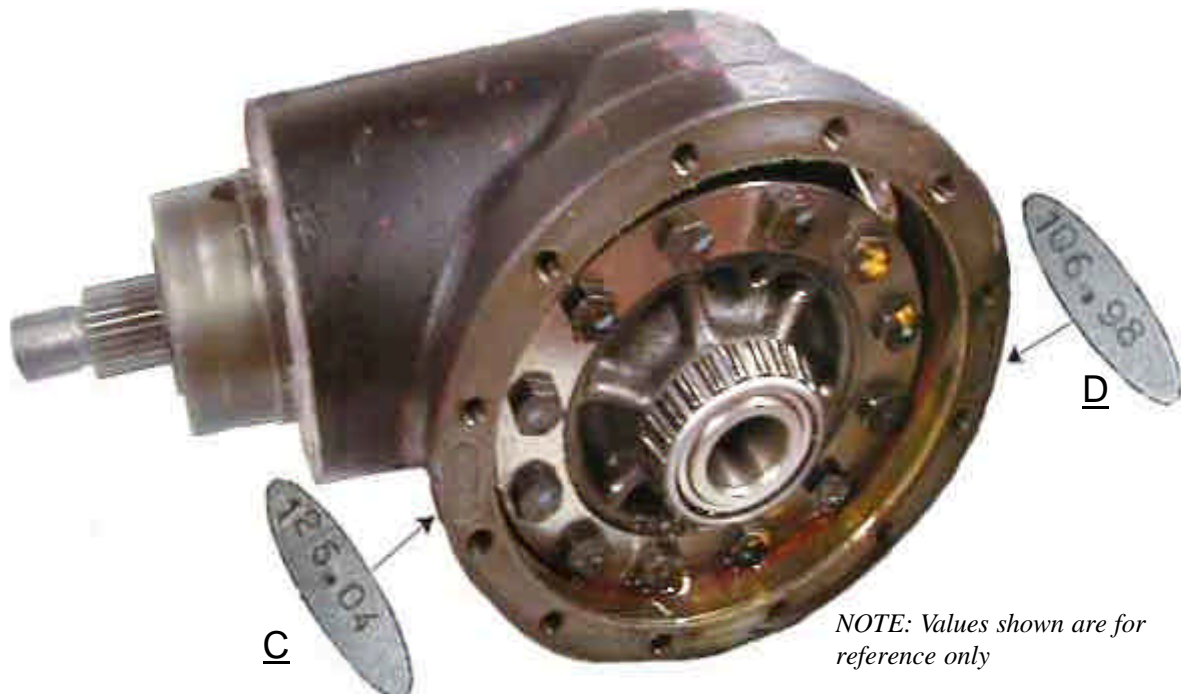

Suspension

TABLE OF CONTENTS

Replace the Rear Springs	2
Replace the Front Springs	3
Replace the Spring Bushings	4
Replace the Shocks	5

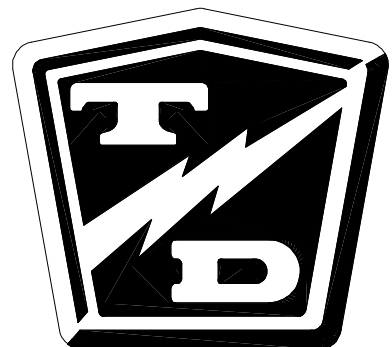



REPLACE THE REAR SPRINGS

If a spring has failed or is fatigued, then it is recommended that both rear springs are replaced as a set.

HINT : In most vehicles it will be easier if the springs are replaced one at a time.

⚠ WARNING

1. Make sure the key-switch is in the "OFF" position, then remove the key.
2. Place the forward-reverse switch in the center "OFF" position.
3. Set the park brake.
4. Place blocks under the front wheels to prevent vehicle movement.
5. Disconnect the main positive and negative cables at the batteries.

6. Raise the rear of the vehicle and support with jack stands.

⚠ WARNING

Always use a lifting strap, hoist, and jack stands, of adequate capacity to lift and support the vehicle. Failure to use lifting and support devices of rated load capacity may result in severe bodily injury.

7. Tie up or support the rear axle so it cannot fall out of the vehicle.
8. Unbolt the spring from the axle housing.
9. Support the spring so that it cannot fall out of the vehicle.
10. Remove the remaining hardware retaining the spring to the frame.
11. Remove the spring from the vehicle.
12. Inspect the spring bolts and spring hangers for signs of wear or damage. If any wear or damage is found, then they must be replaced.

⚠ WARNING

Damaged or worn spring bolts or hangers could result in sudden failure of the suspension causing severe bodily injury or property damage.

13. Install the new spring in reverse order.
14. If the spring hanger bolts do not have a grease fitting, lube the spring bushings before installing the spring.
15. Tighten the spring hanger bolts securely, but not so tight as to bind the spring.
16. Lower the vehicle.
17. Reconnect the main positive and negative cables at the batteries.
18. Remove the blocks from behind the wheels.
19. Release the parking brake and test drive the vehicle.

REPLACE THE FRONT SPRINGS

If a spring has failed or is fatigued, then it is recommended that both front springs are replaced as a set.

HINT : In most vehicles it will be easier if the springs are replaced one at a time.

⚠ WARNING

1. Make sure the key-switch is in the "OFF" position, then remove the key.
2. Place the forward-reverse switch in the center "OFF" position.
3. Set the park brake.
4. Place blocks under the rear wheels to prevent vehicle movement.
5. Disconnect the main positive and negative cables at the batteries.

6. Raise the front of the vehicle and support with jack stands.

⚠ WARNING

Always use a lifting strap, hoist, and jack stands, of adequate capacity to lift and support the vehicle. Failure to use lifting and support devices of rated load capacity may result in severe bodily injury.

7. Tie up or support the front axle so it cannot fall out of the vehicle.
8. Unbolt the spring from the front axle beam.
9. Support the spring so that it cannot fall out of the vehicle.
10. Remove the lower bolt from the spring hanger.
11. Remove the spring bolt from the other end of the spring and remove the spring from the vehicle.
12. Inspect the spring bolts and spring hangers for signs of wear or damage. If any wear or damage is found, then they must be replaced.
13. Install the new spring in reverse order.
14. If the spring hanger bolts do not have a grease fitting, lube the spring bushings before installing the spring.
15. Torque the spring hanger bolts to 20 ft-lbs.
16. If the spring bolts are equipped with grease fittings, lube them at this time.
17. Lower the vehicle.
18. Reconnect the main positive and negative cables at the batteries.
19. Remove the blocks from behind the wheels.
20. Release the parking brake and test drive the vehicle.

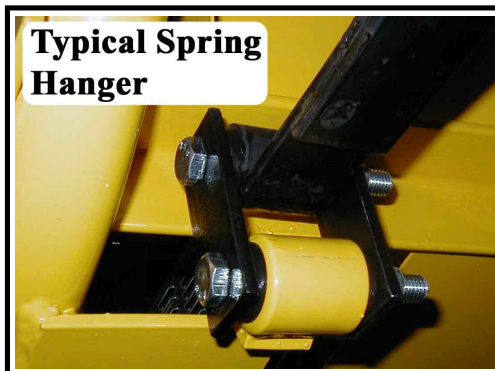

⚠ WARNING

Damaged or worn spring bolts or hangers could result in sudden failure of the suspension causing severe bodily injury or property damage.



REPLACE THE SPRING BUSHINGS

It is recommended that all front spring bushings are replaced as a set.

Your vehicle will be equipped with one of two types of spring bushings, internal and external (see illustration to the right):

- The internal bushing is a plastic insert that is pressed into the spring eye. There are one of these bushings for each spring eye.
- The external bushing consists of two plastic bushings on each end of the spring eye.
- Refer to the parts list to identify the bushings used in your vehicle.

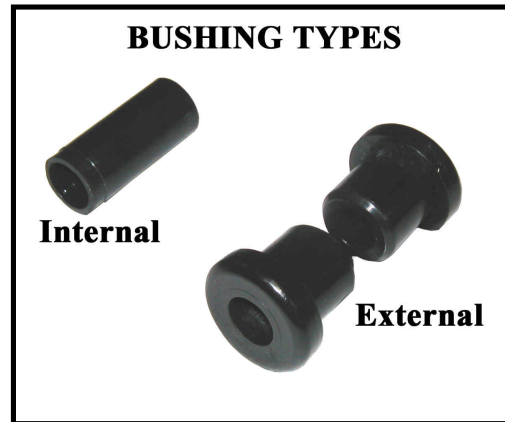

⚠ WARNING

1. Make sure the key-switch is in the "OFF" position, then remove the key.
2. Place the forward-reverse switch in the center "OFF" position.
3. Set the park brake.
4. Place blocks under the front/rear wheels to prevent vehicle movement.
5. Disconnect the main positive and negative cables at the batteries.

6. Raise the front or rear of the vehicle depending on which spring is to be removed and support with jack stands.

⚠ WARNING

Always use a lifting strap, hoist, and jack stands, of adequate capacity to lift and support the vehicle. Failure to use lifting and support devices of rated load capacity may result in severe bodily

7. Remove the spring from the vehicle.

*NOTE: Refer to **Replace the Front Springs** section for information regarding removing the front springs.*

8. If the vehicle is equipped with spring hangers, remove the spring hanger bolt from the vehicles frame.
9. Remove the spring bushing(s):
 - For internal bushing, press the spring bushings out of the two spring eyes and from the mounting eye on the vehicles frame.
 - For external bushing, Remove the bushings from the spring eye.
10. Install the new bushings in reverse order.

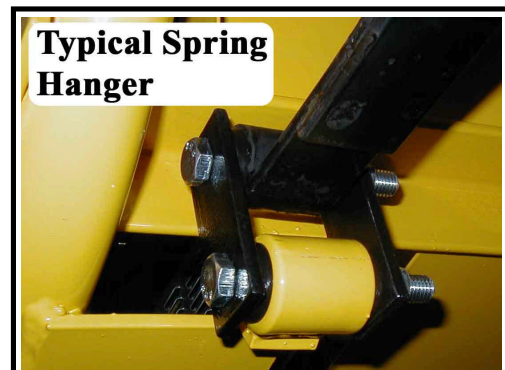

REPLACE THE SHOCKS

It is recommended to replace all shocks as a set.

NOTE: On some vehicles it may be required to remove the front wheel to gain access to the shock mounting bolts. Refer to Tires and Wheels section for information regarding removing the front wheels.

⚠ WARNING

- 1. Make sure the key-switch is in the "OFF" position, then remove the key.**
- 2. Place the forward-reverse switch in the center "OFF" position.**
- 3. Set the park brake.**
- 4. Place blocks under the front wheels to prevent vehicle movement.**
- 5. Disconnect the main positive and negative cables at the batteries.**

6. Some vehicles may require that the wheels be lifted off of the ground and supported with jack stands to replace the shocks.

⚠ WARNING

Always use a lifting strap, hoist, and jack stands, of adequate capacity to lift and support the vehicle. Failure to use lifting and support devices of rated load capacity may result in severe bodily

7. Remove the upper and lower shock bolts.
8. Remove the shock from the vehicle.

NOTE: If the shock that was removed is to be reinstalled:

- A. *Inspect the shaft where it enters the shock body for any signs of leakage. If any sign of leakage is seen, then the shock must be replaced.*
- B. *Inspect the upper and lower shock bushings. If any signs of damage or wear are seen, then the shock must be replaced.*

9. Install the shock in reverse order.
10. Lower the vehicle.
11. Reconnect the main positive and negative cables at the batteries.
12. Remove the blocks from behind the wheels.
13. Release the parking brake and test drive the vehicle.



TAYLOR - DUNN

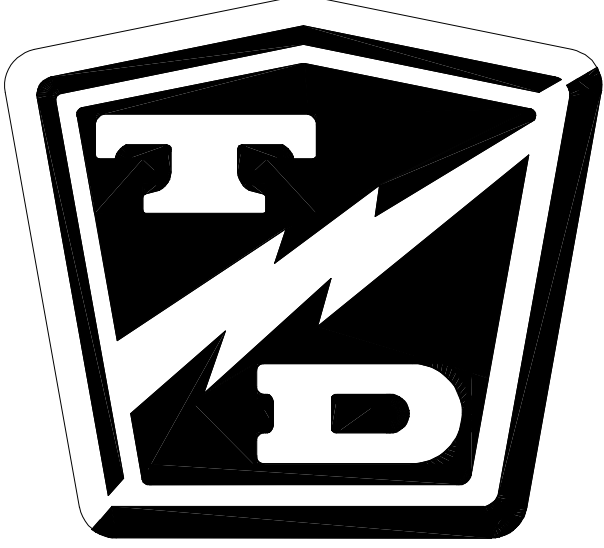

Tires and Wheels

TABLE OF CONTENTS

Tire Inflation	2
Tire Inspection	2
Replace the Tire/Wheel	3
Repair the Tire (pneumatic)	4
Replace the Tire (pneumatic).....	5

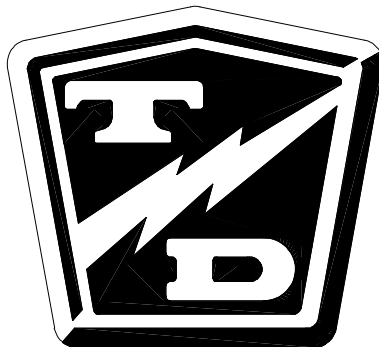



TIRE INFLATION

⚠ WARNING

1. Make sure the key-switch is in the "OFF" position, then remove the key.
2. Place the forward-reverse switch in the center "OFF" position.
3. Set the park brake.
4. Place blocks under the front wheels to prevent vehicle movement.
5. Disconnect the main positive and negative cables at the batteries.

There are many tire options available with varying tire pressures. Refer to the side wall of your tire for information regarding the tire pressure for your tires.

The illustration to the right is an example of the side wall information on a tire.

Tire pressures must be checked when the tire is cold.



TIRE INSPECTION

⚠ WARNING

1. Make sure the key-switch is in the "OFF" position, then remove the key.
2. Place the forward-reverse switch in the center "OFF" position.
3. Set the park brake.
4. Place blocks under the front wheels to prevent vehicle movement.
5. Disconnect the main positive and negative cables at the batteries.

6. Check the tire pressure. Refer to *Tire Inflation* section for information on checking the tire pressure.
7. Inspect the tire tread depth. Minimum recommended tread depth is 1/16-inch. There are a series of tread depth wear indicators around the circumference of the tire. They will appear as 1/2-inch bands across the tread as the tire approaches its wear limit (see illustration to the right). Replace the tire if any tread depth indicator can be seen or any part of the tread depth is 1/16-inch or less. Refer to *Replace the Tire* section for information regarding replacing the tire.



8. Inspect for uneven tire wear on the front tires. Uneven tire wear could be a result of an improperly inflated tire or a misaligned or damaged front end.

*NOTE: Refer to **Tire Inflation** section or **Steering Component Service** section for information on proper tire inflation or front end wheel alignment.*

9. Inspect the inner and outer side walls for cracks. If any cracks are seen, then the tire should be replaced. Refer to **Replace the Tire** section for information regarding replacing the tire.
10. Inspect the valve stem for cracks. If any cracks are seen, then the valve stem should be replaced. It is also recommended that the valve stem be replaced whenever the tire is replaced.

*NOTE: Refer to **Replace the Tire** section for information regarding replacing the valve stem.*

11. Inspect the tread and side walls for debris in the rubber that could lead to a puncture. If any debris is found it should be removed and the tire inspected for a leak.

REPLACE THE TIRE/WHEEL

WARNING

1. Make sure the key-switch is in the "OFF" position, then remove the key.
2. Place the forward-reverse switch in the center "OFF" position.
3. Set the park brake.
4. Place blocks under the front wheels to prevent vehicle movement.
5. Disconnect the main positive and negative cables at the batteries.

6. Raise the wheel to be replaced off of the ground and support with jack stands.
7. Remove the 4 or 5 wheel nuts and remove the wheel.
8. Install in reverse order.
9. Following the pattern shown on the following page, cross tighten the wheel nuts in two stages as follows:
 - 1st stage to approximately 20 ft-lbs.
 - 2nd stage to 80-90 ft-lbs.
10. Reconnect the main positive and negative cables at the batteries.
11. Lower the wheel to the ground.
12. Remove the blocks from behind the wheels.
13. Release the parking brake and test drive the vehicle.

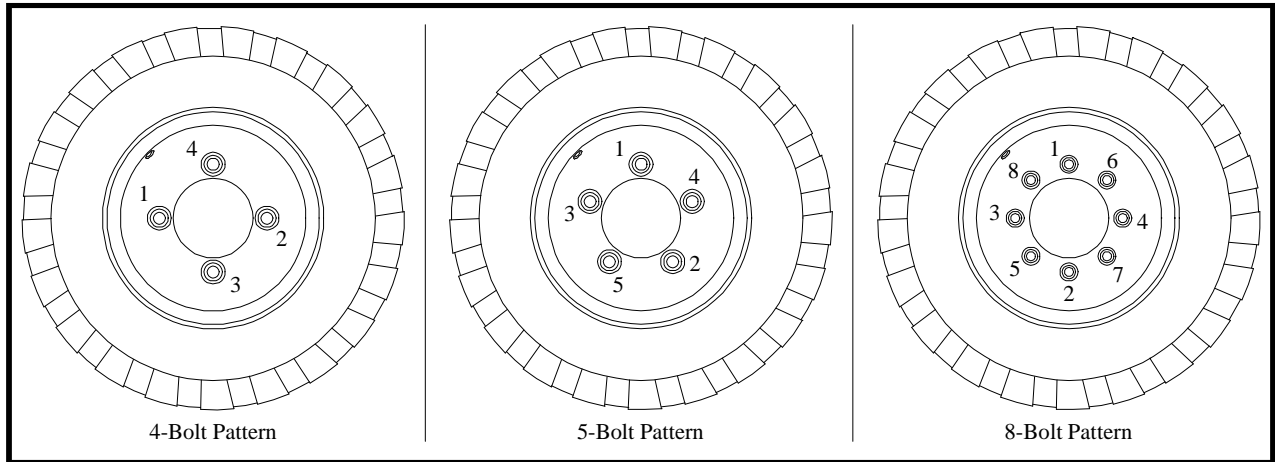

Pattern for tightening the wheel nuts

⚠ WARNING

Re-torque all wheel nuts to their final value after 1-week (20-hours) of operation. Failure to re-torque the wheel nuts may result in the wheel coming off of the vehicle causing severe bodily injury and/or property damage.

REPAIR THE TIRE (PNEUMATIC)

⚠ WARNING

Do not attempt to repair a tire with a damaged side wall or a slice in the tread. This type of repair could fail prematurely resulting in severe bodily injury and/or property damage.

*NOTE: To properly repair a puncture, the tire must be removed from the wheel. Refer to **Replace the Tire** section for information on removing the tire from the wheel.*

It is recommended to repair a tire with a combination vulcanized plug and internal patch.

Tire repairs should only be performed by personnel trained in tire repair.

The tire repair procedure will be unique to the type of repair equipment or repair components used. Refer to the instructions provided with your equipment or repair components.

REPLACE THE TIRE (PNEUMATIC)

*NOTE: To replace the tire, the tire/wheel assembly must be removed from the vehicle. Refer to **Replace the Tire/Wheel** section for information on removing the tire/wheel assembly.*

WARNING

Explosion Hazard. Fully deflate the tire before attempting to remove the tire from the wheel. Do not over inflate the tire when seating the bead. Failure to deflate the tire or over inflating the tire to seat the bead may cause explosive failure of the tire resulting in severe bodily injury or death.

Tire replacement should only be performed by personnel trained in tire replacement.

The tire replacement procedure will be unique to the type of replacement equipment being used. Refer to the instructions provided with your equipment.

Always use a new valve stem when replacing a tire.

1. Remove the tire from the wheel.
2. Cut the old valve stem off of the wheel.
3. Remove the valve stem cap from the new valve stem.
4. Lubricate the valve stem with liquid soap.
5. Install a new valve stem using a valve stem tool.

NOTE: The valve stem tool is available at most auto repair shops.

6. Install the tire onto the wheel following the instructions provided with your tire replacement equipment.
7. Inflate the tire to the proper pressure and check for leaks.
8. Install the valve stem cap.

TAYLOR - DUNN

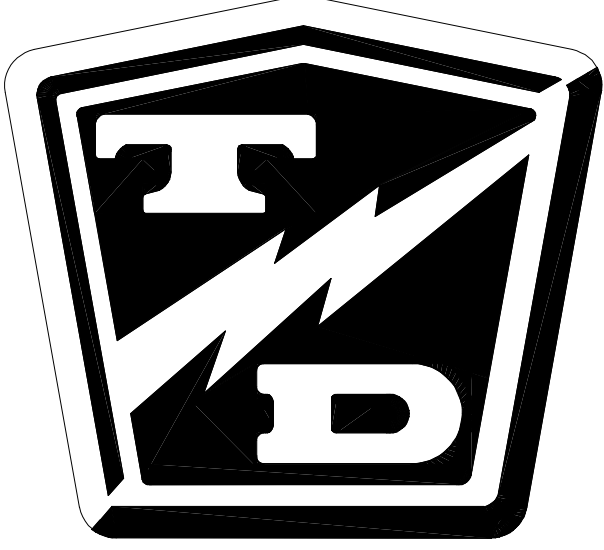

Battery Service

TABLE OF CONTENTS

Cleaning	2
Testing	3
Watering	5
Charging	6
Replacing (6-volt batteries only)	7
Moist Charge Batteries	9
Storage and Returning to Service	10
Storage	10
Returning to Service	11

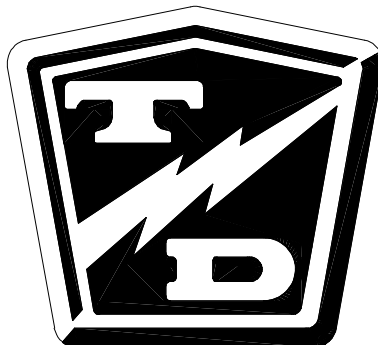



CLEANING

⚠ WARNING

Explosive mixtures of Hydrogen gas are present within battery cells at all times. Do not work with or charge battery in an area where open flames (including gas furnace or water heater pilots), sparks, cigarettes, or any other sources of combustion are present. Always provide ample ventilation in rooms where batteries are being charged. Failure to do so may result in severe bodily injury and/or property damage.

⚠ WARNING

Battery electrolyte is poisonous and dangerous. It contains sulfuric acid. Avoid contact with skin eyes or clothing. Wear rubber gloves and safety glasses while servicing batteries. **DO NOT INGEST!** This may result in severe bodily injury.

⚠ WARNING

A battery is a live electrical source. It cannot be disconnected or neutralized. Do not drop any tool or conductive object onto the battery. A conductive object that comes in contact with the battery terminals will initiate a short circuit of the battery. This could cause the battery to explode resulting in severe bodily injury and/or property damage.

⚠ CAUTION

Battery electrolyte will stain and corrode most surfaces. Immediately and thoroughly clean any surface outside of the battery that the battery electrolyte comes in contact with. Failure to clean may result in property damage.

⚠ WARNING

1. Make sure the key-switch is in the "OFF" position, then remove the key.
2. Place the forward-reverse switch in the center "OFF" position.
3. Set the park brake.
4. Place blocks under the front wheels to prevent vehicle movement.
5. Disconnect the main positive and negative cables at the batteries.

6. Dry dirt can be readily blown off with low-pressure air or brushed off.
7. Wetness or wet dirt on the batteries indicates battery acid. Using a nonmetallic brush with flexible bristles, wash the batteries off with a strong solution of baking soda and hot water (1 lb. of soda to a gallon of water). Continue until all fizzing stops, which indicates that the acid has been neutralized. Then rinse thoroughly with clear water. **DO NOT** get any of the solution into the battery cells.
8. Reconnect the batteries, remove the blocks from the wheels and test drive.

TESTING

NOTE: A combination of the Load Test and Specific Gravity Test should be used to accurately determine the condition of the batteries.

WARNING

Explosive mixtures of Hydrogen gas are present within battery cells at all times. Do not work with or charge battery in an area where open flames (including gas furnace or water heater pilots), sparks, cigarettes, or any other sources of combustion are present. Always provide ample ventilation in rooms where batteries are being charged. Failure to do so may result in severe bodily injury and/or property damage.

WARNING

Battery electrolyte is poisonous and dangerous. It contains sulfuric acid. Avoid contact with skin eyes or clothing. Wear rubber gloves and safety glasses while servicing batteries. **DO NOT INGEST!** This may result in severe bodily injury.

WARNING

A battery is a live electrical source. It cannot be disconnected or neutralized. Do not drop any tool or conductive object onto the battery. A conductive object that comes in contact with the battery terminals will initiate a short circuit of the battery. This could cause the battery to explode resulting in severe bodily injury and/or property damage.

WARNING

1. Make sure the key-switch is in the "OFF" position, then remove the key.
2. Place the forward-reverse switch in the center "OFF" position.
3. Set the park brake.
4. Place blocks under the front wheels to prevent vehicle movement.
5. Disconnect the main positive and negative cables at the batteries.

Load Test (6-volt batteries only)

NOTE: The batteries must be fully charged before performing this test.

1. Clean the batteries. Refer to **Cleaning the Batteries** section for information on cleaning the batteries.
2. Load test each battery using a battery load test meter (available at most auto parts distributors). Follow the instructions provided with the test meter.
 - If any battery fails the load test, then it should be replaced.

NOTE: If the batteries are over one year old, it is recommended to replace them as a set.

- If all batteries fail the test you should check the charging system before replacing the batteries. Refer to **Charger Troubleshooting** section for information on checking the charging system.



Specific Gravity Test

NOTE: The batteries must be fully charged before performing this test.

The specific gravity of a cell is an indication of the actual state of charge of the cell. A fully charged cell should have a reading of 1275 to 1300 (see the illustration to the right). A discharged battery will read 1100. Ideally, all cells in a battery pack will have the same reading. Any cells in a battery pack that vary by more than 30-points may be an indication of a bad cell.

Clean the batteries. Refer to ***Cleaning the Batteries*** section for information on cleaning the batteries.

Using part number **77-200-00** hydrometer, check and record the specific gravity of each cell in the battery pack.

If, after charging, none of the cells exceed a hydrometer reading of 1250 then there may be a fault in the charging system. If the charging system checks OK then the batteries are no longer accepting a charge and should be replaced.

*NOTE: Refer to **Charger Troubleshooting** for information on checking the charging system.*

The highest reading will be the cell that is accepting the most charge. This reading will be used to gauge all other cells.

Compare the specific gravity readings to the highest reading, if the difference between any of the cells is more than 30-points, then that battery should be replaced.

NOTE: If the batteries are over one year old, it is recommended to replace them as a set.

Reconnect the batteries, remove the blocks from the wheels and test drive.

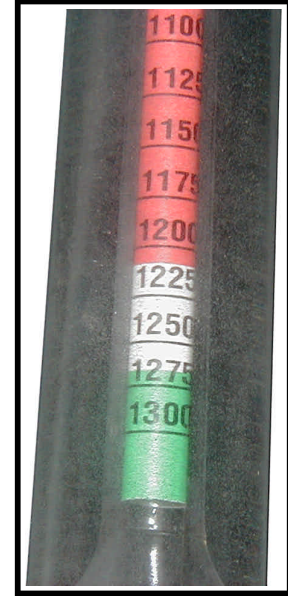

Typical Hydrometer Float

WATERING

NOTE: The electrolyte level in a battery rises while charging and will be close to its highest level after the end of a charging cycle. It is recommended to fill the batteries at the end of a charging cycle. If the electrolyte is below the top of the battery plates then fill just enough to cover the plates and then top off when the charging cycle is complete.

⚠ WARNING

Explosive mixtures of Hydrogen gas are present within battery cells at all times. Do not work with or charge battery in an area where open flames (including gas furnace or water heater pilots), sparks, cigarettes, or any other sources of combustion are present. Always provide ample ventilation in rooms where batteries are being charged. Failure to do so may result in severe bodily injury and/or property damage.

⚠ WARNING

Battery electrolyte is poisonous and dangerous. It contains sulfuric acid. Avoid contact with skin eyes or clothing. Wear rubber gloves and safety glasses while servicing batteries. DO NOT INGEST! This may result in severe bodily injury.

⚠ WARNING

A battery is a live electrical source. It cannot be disconnected or neutralized. Do not drop any tool or conductive object onto the battery. A conductive object that comes in contact with the battery terminals will initiate a short circuit of the battery. This could cause the battery to explode resulting in severe bodily injury and/or property damage.

⚠ WARNING

- 1. Make sure the key-switch is in the "OFF" position, then remove the key.**
- 2. Place the forward-reverse switch in the center "OFF" position.**
- 3. Set the park brake.**
- 4. Place blocks under the front wheels to prevent vehicle movement.**
- 5. Disconnect the main positive and negative cables at the batteries.**

⚠ WARNING

Do not overfill the batteries. Over filling the batteries may cause the batteries to boil over and result in severe bodily injury or property damage.



⚠ WARNING

1. Make sure the key-switch is in the "OFF" position, then remove the key.
2. Place the forward-reverse switch in the center "OFF" position.
3. Set the park brake.
4. Place blocks under the front wheels to prevent vehicle movement.
5. Disconnect the main positive and negative cables at the batteries.

6. Clean the batteries. Refer to ***Cleaning the Batteries*** section for information on cleaning the batteries.
7. Check the electrolyte level in all battery cells. If low, fill to the correct level with distilled water using part number **77-201-00** battery filler, never add additional battery electrolyte to the batteries.
8. Reconnect the batteries, remove the blocks from the wheels and test drive.

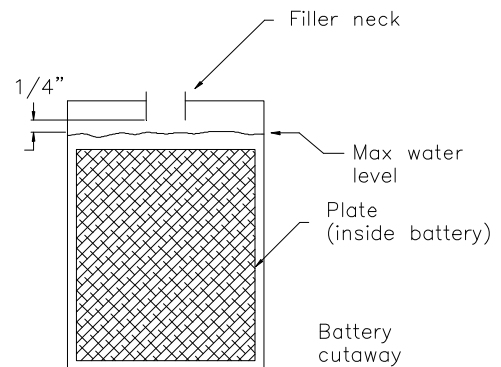

CHARGING

Refer to ***Charging Your Vehicle*** in section ***Safety Rules and Operating Instructions***.

REPLACING (6-VOLT BATTERIES ONLY)

WARNING

Explosive mixtures of Hydrogen gas are present within battery cells at all times. Do not work with or charge battery in an area where open flames (including gas furnace or water heater pilots), sparks, cigarettes, or any other sources of combustion are present. Always provide ample ventilation in rooms where batteries are being charged. Failure to do so may result in severe property damage and or serious

WARNING

Battery electrolyte is poisonous and dangerous. It contains sulfuric acid. Avoid contact with skin eyes or clothing. Wear rubber gloves and safety glasses while servicing batteries. **DO NOT INGEST!** This may result in serious bodily injury.

WARNING

A battery is a live electrical source. It cannot be disconnected or neutralized. Do not drop any tool or conductive object onto the battery. A conductive object that comes in contact with the battery terminals will initiate a short circuit of the battery. This could cause the battery to explode resulting in property damage and/or bodily injury.

WARNING

1. Make sure the key-switch is in the "OFF" position, then remove the key.
2. Place the forward-reverse switch in the center "OFF" position.
3. Set the park brake.
4. Place blocks under the front wheels to prevent vehicle movement.
5. Disconnect the main positive and negative cables at the batteries.

NOTE: If the batteries are over one year old, it is recommended to replace them as a set.

6. Thoroughly clean the batteries and battery compartment. Refer to **Cleaning** in this section for information regarding cleaning the batteries.

CAUTION

Battery electrolyte will stain and corrode most surfaces. Immediately and thoroughly clean any surface outside of the battery that the battery electrolyte comes in contact with. Failure to clean may result in property damage.



7. Remove the battery hold downs.
8. Inspect the battery hold downs for corrosion. If any signs of corrosion are seen then the battery hold downs should be replaced.
9. Remove all battery jumpers from both posts of the battery or batteries being replaced.

NOTE: It is recommended to replace the battery jumpers when replacing the batteries.

10. Remove the batteries from the vehicle.

⚠ WARNING

Do not leave cables on batteries that have been removed from the vehicle. Cables left on batteries could cause a short circuit resulting in battery explosion, severe bodily injury and/or property damage.

11. Inspect the battery compartment for signs of corrosion.
12. If minimal signs of corrosion are seen, then the damaged paint should be stripped off and the entire battery compartment prepped and repainted.
13. If there are excessive signs of corrosion, then it may be necessary to replace some of the frame members or completely rebuild the battery compartment.
14. Inspect the main positive and negative cables and terminals, charger cables and terminals and 12-volt tap wiring. If any of the terminals or wires show signs of corrosion, then they must be repaired or replaced.
15. Install the batteries in reverse order. Refer to the *Illustrated Parts List* for battery cable routing.
16. It is recommended to replace the battery terminal hardware when replacing the batteries.
17. Torque the terminal hardware to 7-8 ft.-lbs.
18. Tighten the hold downs so that the batteries are secure but not so tight as to deform the batteries.

⚠ CAUTION

When torquing battery hardware, use a backup wrench on the battery bolt and tighten the nut. Failure to use a backup wrench may damage the battery post.

19. Remove the blocks from the wheels and test drive.

Moist Charge Batteries

⚠ WARNING

Explosive mixtures of Hydrogen gas are present within battery cells at all times. Do not work with or charge battery in an area where open flames (including gas furnace or water heater pilots), sparks, cigarettes, or any other sources of combustion are present. Always provide ample ventilation in rooms where batteries are being charged. Failure to do so may result in severe property damage and or serious

⚠ WARNING

Battery electrolyte is poisonous and dangerous. It contains sulfuric acid. Avoid contact with skin eyes or clothing. Wear rubber gloves and safety glasses while servicing batteries. **DO NOT INGEST!** This may result in serious bodily injury.

⚠ WARNING

A battery is a live electrical source. It cannot be disconnected or neutralized. Do not drop any tool or conductive object onto the battery. A conductive object that comes in contact with the battery terminals will initiate a short circuit of the battery. This could cause the battery to explode resulting in property damage and/or bodily injury.

Moist charged batteries are shipped without battery electrolyte. This allows for a much greater shelf life of the battery. Moist charged batteries must be filled with electrolyte and charged before putting into service. Battery electrolyte is a solution of acid and water that is formulated to be used in wet lead acid batteries and is available at most automotive parts distributors that carry batteries.

⚠ CAUTION

Do not operate or charge a vehicle equipped with moist charged batteries until the batteries have been filled with electrolyte and charged. Operating or charging moist charged batteries before filling and charging will damage the batteries resulting in premature failure of the batteries.

⚠ WARNING

1. Make sure the key-switch is in the "OFF" position, then remove the key.
2. Place the forward-reverse switch in the center "OFF" position.
3. Set the park brake.
4. Place blocks under the front wheels to prevent vehicle movement.
5. Disconnect the main positive and negative cables at the batteries.



Maintenance, Service, and Repair

6. Fill all battery cells with electrolyte to the proper level.
7. Thoroughly clean any spilled electrolyte from the batteries or the ground. Refer to **Cleaning the Batteries** for information on cleaning the batteries.
8. Reconnect the battery cables, connect the batteries to the charger and allow the charger to complete one charging cycle.
9. Remove the blocks from the wheels and test drive. The batteries are now ready to be put into service.

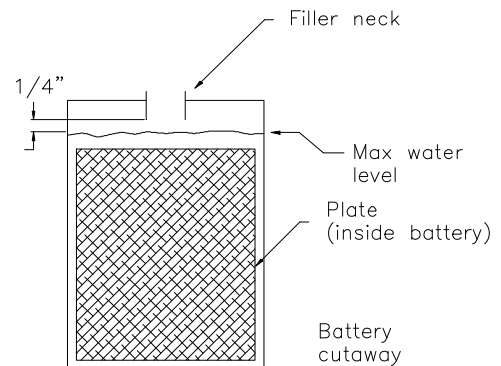

CAUTION

Battery electrolyte will stain and corrode most surfaces. Immediately and thoroughly clean any surface outside of the battery that the battery electrolyte comes in contact with. Failure to clean may result in property damage.

STORAGE AND RETURNING TO SERVICE

Storage

CAUTION

If the batteries are removed from the vehicle, do not place them directly on the ground, concrete or solid metal surface. It is recommended to store them on a wooden pallet or equivalent. Storing on the ground, concrete or solid metal surface will cause the batteries to discharge and may result in premature failure of the batteries.

Thoroughly clean the batteries and battery compartment. Refer to **Cleaning** in this section for information regarding cleaning the batteries.

Check the electrolyte level and charge the batteries. Refer to **Watering** in this section for information regarding checking the electrolyte level.

Store the vehicle or batteries in a cool, dry, well ventilated area.

If storing for more than one month, the batteries should be charged as follows:

Storage Temperature (F)	Charging Interval (months)
Over 60	1
Between 40 and 60	2
Below 40	6

Returning to Service

⚠ WARNING

Explosive mixtures of Hydrogen gas are present within battery cells at all times. Do not work with or charge battery in an area where open flames (including gas furnace or water heater pilots), sparks, cigarettes, or any other sources of combustion are present. Always provide ample ventilation in rooms where batteries are being charged. Failure to do so may result in severe property damage and or serious

⚠ WARNING

Battery electrolyte is poisonous and dangerous. It contains sulfuric acid. Avoid contact with skin eyes or clothing. Wear rubber gloves and safety glasses while servicing batteries. **DO NOT INGEST!** This may result in serious bodily injury.

⚠ WARNING

A battery is a live electrical source. It cannot be disconnected or neutralized. Do not drop any tool or conductive object onto the battery. A conductive object that comes in contact with the battery terminals will initiate a short circuit of the battery. This could cause the battery to explode resulting in property damage and/or bodily injury.

⚠ WARNING

1. Make sure the key-switch is in the "OFF" position, then remove the key.
2. Place the forward-reverse switch in the center "OFF" position.
3. Set the park brake.
4. Place blocks under the front wheels to prevent vehicle movement.
5. Disconnect the main positive and negative cables at the batteries.

6. Thoroughly clean the batteries and battery compartment. Refer to **Cleaning** in this section for information regarding cleaning the batteries.

⚠ CAUTION

Battery electrolyte will stain and corrode most surfaces. Immediately and thoroughly clean any surface outside of the battery that the battery electrolyte comes in contact with. Failure to clean may result in property damage.

7. Check the electrolyte level and charge the batteries. Refer to **Watering** in this section for information regarding checking the electrolyte level.
8. Test the batteries. Refer to **Testing** section for information on testing the batteries.
9. The batteries are now ready to be put back into service.

TAYLOR - DUNN

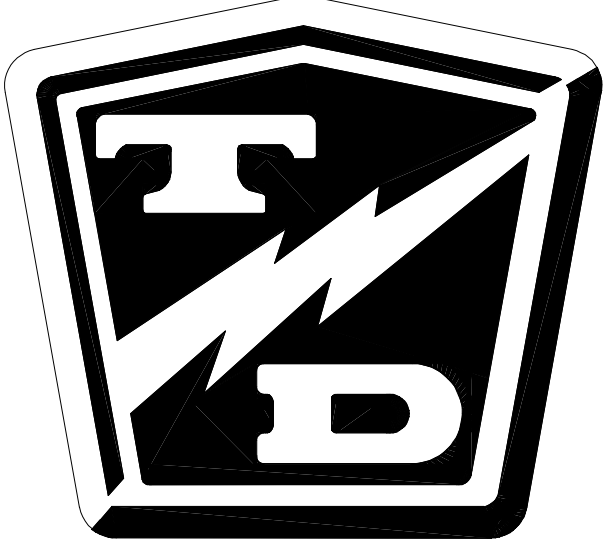

Sevcon Control System Troubleshooting

Includes Power Pak and Micro Pak controllers

TABLE OF CONTENTS

Test Equipment Required:	2
Definitions:	2
Terminology used:	2
Important Notes and Instructions	2
Identifying Your Controller	3
Start Troubleshooting Here	4
Test 8. Anti-Rolloff Fault	15
Test 9. Electric Motor Brake	16
Logic Voltage Reference Table	18
Status LED Code Table	19
Smart View Fault Codes	20

⚠ CAUTION

Turn the Key switch OFF **BEFORE** disconnecting the batteries. Disconnecting the batteries with the key switch ON may corrupt the controller programming resulting in a fault code 1 (refer to fault table).

⚠ CAUTION

This troubleshooting guide is written in sequential order. All tests must be performed in the order that they are written. Starting in the middle or skipping sections when not instructed to do so may lead to invalid test results.

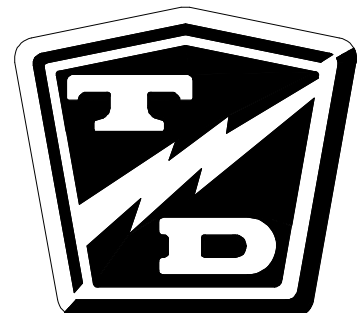



Test Equipment Required:

- Digital multimeter (DMM) with diode test function, FLUKE 79 model shown.
- Throttle Module Analyzer, Taylor-Dunn part number 62-027-32

Definitions:

- Battery volts = full voltage available at the batteries at the time of test.
- High: Greater than +4.5 volts
- Low: Less than +1.8 volts

Terminology used:

- The “HOT” side of a switch is the terminal that the power is connected to.
- The “COLD” side of a switch is the terminal that the power is switched to.
- FS-1 = Micro-switch in the accelerator module.

DURING ALL TESTS

- After any repairs are made, completely retest vehicle before lowering the drive wheels to the ground.

⚠ CAUTION

Turn the Key switch OFF BEFORE disconnecting the batteries. Disconnecting the batteries with the key switch ON may corrupt the controller programming resulting in a fault code 1 (refer to fault table).

⚠ WARNING

Turn the Key switch OFF then disconnect both of the battery leads during any maintenance or before disconnecting any electrical component or wire. Failure to do so may cause severe bodily injury and/or property damage.

⚠ WARNING

The rear drive wheels may rotate during some of the following tests. Block the front wheels, raise the rear drive wheels off the ground, and support the vehicle with jack stands. Failure to do so may cause the vehicle to move and cause property damage and/or serious bodily injury.

Important Notes and Instructions

- This troubleshooting procedure is for the Sevcon Power Pak and Micro Pak motor speed controllers as equipped in standard vehicles. Troubleshooting may not be valid for vehicles equipped with special order speed control options.
- For additional troubleshooting information, use the handheld system analyzer part number 62-027-61 or the computer system analyzer (PCpaK) part number 62-027-63. See note below.
- This troubleshooting guide assumes a familiarity with the use of a digital multimeter including, voltage tests, continuity tests, and diode testing. If you are not familiar with these types of tests then refer testing to a qualified technician.
- These tests are not intended to locate a problem on an incorrectly wired vehicle.
- Make sure the batteries are in good condition and fully charged before performing any tests.
- If the vehicle exhibits intermittent problems, it must be in the failed mode for troubleshooting. If it is running normally when the testing is done then the problem will not be identified.
- Some tests refer to a High/Low switch. The High/Low switch is optional and the vehicle may not be equipped with this option. If the vehicle is without this option, there is a jumper bypass installed in place of the switch in the dash.
- All voltage tests are done referenced to battery negative, unless otherwise specified.
- At the start of each test sequence you will be instructed on how to place the control switches. While testing, do not change the position of any switches unless instructed to do so.

Note: The PCpaK application is also capable of uploading new controller parameters to the controller. Controller parameter sets are available from Taylor-Dunn. Individual parameters cannot be changed.

⚠ CAUTION

This troubleshooting guide is written in sequential order. All tests must be performed in the order that they are written. Starting in the middle or skipping sections when not instructed to do so may lead to invalid test results.

Identifying Your Controller



PowerPak Controller



MicroPak Controller



PowerPak Logic Connector

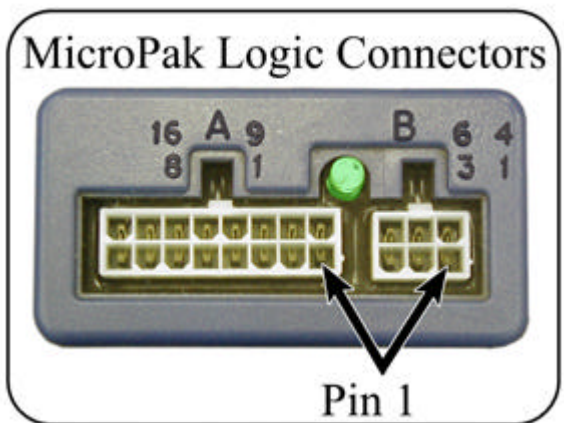

Pin 1

START TROUBLESHOOTING HERE

⚠ CAUTION

If your vehicle is equipped with an electric motor brake, the motor brake system must be checked to be sure it is working properly before continuing with this troubleshooting. Operating the speed control when the motor brake has not disengaged may result in damage to the motor or speed control system. Refer to **Test 9: Electric Motor Brake** for information regarding testing the motor brake system.

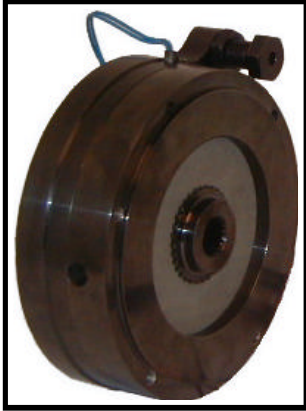

Electric motor brake

The electric motor brake is mounted between the drive motor and the primary reduction gear case. An illustration of the motor brake is shown to the left.

⚠ CAUTION

This troubleshooting guide is written in sequential order. All tests must be performed in the order that they are written. Starting in the middle or skipping sections when not instructed to do so may lead to invalid test results.

If the Battery Status Indicator does not show a charged battery, check the following:

- The batteries
- The wiring from the battery status indicator to the batteries for open circuits
- The battery status indicator
- The positive and negative circuit breaker
- The main circuit breaker for open circuits

Do not continue unless the indicator shows a charged battery.

If the vehicle runs in one direction only, then skip ahead to test #3.

If the vehicle runs slow in forward, but otherwise runs normal, then skip ahead to test #1.3.

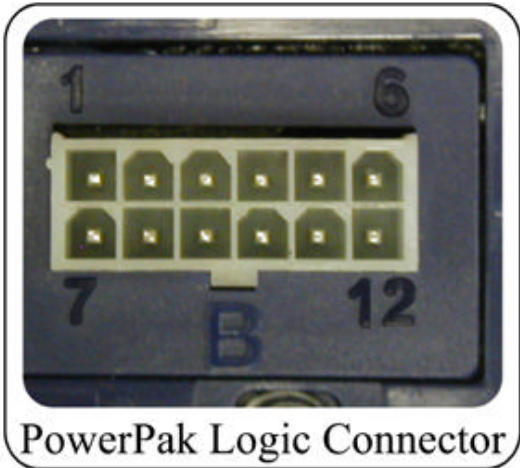

PowerPak Logic Connector

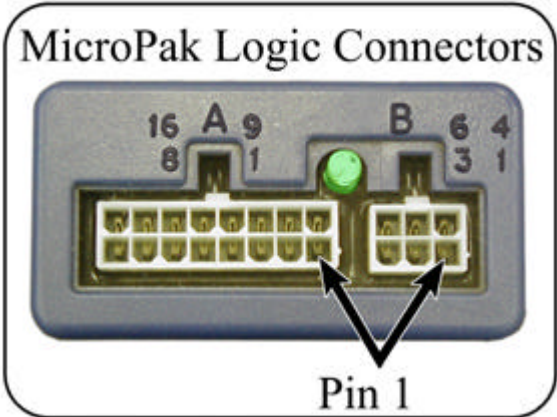

⚠ WARNING

After any repairs are made, completely retest the vehicle before lowering the drive wheels to the ground. Failure to retest the vehicle could result in unexpected movement of the vehicle resulting in injury or property damage.

Test 1. CHECKING THE CONTROL LOGIC INPUTS

Close the seat switch. Place the high/low switch in the HIGH position.

Connect a voltmeter across the ISO solenoid coil terminals and carefully monitor the voltage as the key switch is turned on.

Turn the key switch ON and wait 1-second until the Isolator contactor closes.

Perform the following tests:

TEST 1.1

The coil voltage should start at approximately 24 volts when the key is turned ON, then drop to approximately 15 volts after about 0.5 seconds.

If the test is good, then skip ahead to test # 1.2.

If the voltage starts high, drops to 15 volts, and then drops to 0 volts, then it indicates an open circuit to the main battery positive. Check the continuity of the ISO solenoid contacts, the main circuit breaker, and the wiring to the main battery positive post.

If the voltage is starts at 24 volts but the solenoid does not pick up, then skip ahead to Test #5.

If the voltage does not start at 24 volts, then go to Test #4.

TEST 1.2:

Test the voltage from B+ to B- on the Controller.

If the voltage equals battery volts, then go to Test #1.3.

If the voltage does not equal battery volts, then:

- Check the main positive wire to the circuit breaker for open circuits.
- Check the wire from the circuit breaker to battery positive.
- Check the wire from the contactor to B+ on the controller for open circuits.
- Check the wire from B- to battery negative on the controller for open circuits.

Stop trouble shooting here and repair the problem. When the repair is completed, completely retest the vehicle before lowering the drive wheels to the ground.

TEST 1.3:

Test the voltage at pin #6 on the 12-pin logic card connector.

If the voltage is low, then skip ahead to Test #1.4.

If the voltage is high, then check the wire to the High/Low switch and the High/Low switch for open circuits.

NOTE: The High/Low switch is optional and the vehicle may not have this option. If the vehicle is not equipped with option then there is a jumper bypass installed in place of the switch in the dash. Check the jumper to be sure it is still connected.

Stop trouble shooting here and repair the problem. When the repair is completed, completely retest the vehicle before lowering the drive wheels to the ground.

===== **STOP** =====

TEST 1.4:

Test the voltage at pin #5 on the 12-pin logic card connector.

If the voltage is low, then skip ahead to Test #1.5.

If the voltage is high, then:

- Check the seat switch for open contacts.
- Check that the seat switch is engaging the seat correctly.
- Check the wire from the pin 5 to the seat switch for open circuits.
- Check the wire from the seat switch to B- for open circuits.

If all of the above is in working order, then the logic card may have failed.

Stop trouble shooting here and repair the problem. When the repair is completed, completely retest the vehicle before lowering the drive wheels to the ground.

===== **STOP** =====

Stop, do not continue. Reaching this point indicates a failure in the Sevcon power unit or an error was made during testing. Confirm all previous tests were performed correctly before replacing the Sevcon power unit.

TEST 1.5:

Test the voltage at pin #4 on the 12-pin logic card connector.

If the voltage is high, then skip ahead to Test #1.6.

If the voltage is low, then skip ahead to Test #6.

TEST 1.6:

Test the voltage at pin #7 on the 12-pin logic card connector.

NOTE: Pin #7 is for a parking brake interlock switch. This switch is not available for all vehicles and may not be used.

If the voltage is high, then skip ahead to Test #1.7.

If the voltage is low, then:

- Check the park brake switch for shorted contacts.
- Check the wire to the park brake switch for short circuits to B-

Stop trouble shooting here and repair the problem. When the repair is completed, completely retest the vehicle before lowering the drive wheels to the ground.

TEST 1.7:

Depress the accelerator pedal to engage FS-1 only (creep speed).

Perform the following tests:

Test the voltage at pin #10 on the 12-pin logic card connector.

If the voltage is below 0.3 volts, then skip ahead to Test #1.8.

If the voltage is above 0.3 volts, then skip ahead to Test #6

⚠ CAUTION

This troubleshooting guide is written in sequential order. All tests must be performed in the order that they are written. Starting in the middle or skipping sections when not instructed to do so may lead to invalid test results.

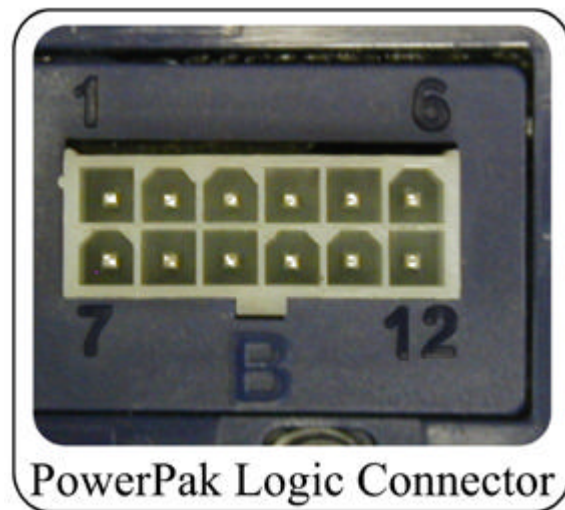
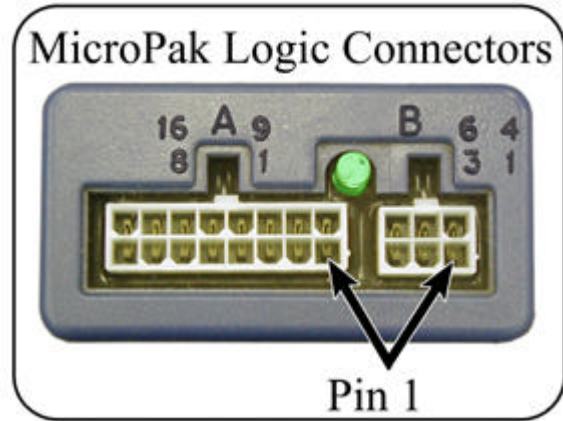

TEST 1.8:

Test the voltage at pin #4 on the 12-pin logic card connector.

If the voltage is low, then skip ahead to Test #1.9.

If the voltage is high, then skip ahead to Test #6.

TEST 1.9:

Depress the accelerator pedal fully.

Test the voltage at pin #10 on the 12-pin logic card connector.

If the voltage is between 4.8 and 5.1 volts, then skip ahead to Test #2.

If the voltage is not between 4.8 and 5.1 volts, then skip ahead to Test #6.

Test 2. TESTING THE MOTOR

⚠ WARNING

1. Make sure the key-switch is in the "OFF" position, then remove the key.
2. Place the forward-reverse switch in the center "OFF" position.
3. Set the park brake.
4. Place blocks under the front wheels to prevent vehicle movement.

⚠ WARNING

Disconnect both of the battery leads during any maintenance or before disconnecting any electrical component or wire. Failure to do so may cause property damage and/or serious bodily injury.

NOTE: Special and expensive motor testing equipment is required in order to accurately measure motor armature or field resistance. In most cases, this equipment is not required in order to determine if a motor is faulty. The majority of motor failures are due to an open circuit in the field or armature windings. If the symptom of the vehicle is "not running with NO motor current" then a simple continuity test of each winding is all that is required to determine if the motor is at fault.

TEST 2.1:

Check the motor field continuity from the motor F1 to the motor F2 terminals.

If the resistance is close to values given in the motor specification table, then skip ahead to test #2.2. (The motor specification table can be found in the "Motor Service" section).

If the test indicates an open circuit, then repair or replace the motor.

Test continuity from F1 to the frame of the motor.

Any reading other than an open circuit indicates a short in the motor.

Stop trouble shooting here and repair the problem. When the repair is completed, completely retest the vehicle before lowering the drive wheels to the ground.



Motor shown in illustrations is typical of a standard motor. The terminal configuration of your motor may be different.

STOP

TEST 2.2:

Check the continuity from the motor A1 to the A2 terminals.

If the resistance is close to values given in the motor specification table, then go to test #2.3.

If the test indicates high resistance or an open circuit, then repair or replace the motor.

Stop trouble shooting here and repair the problem. When the repair is completed, completely retest the vehicle before lowering the drive wheels to the ground.



STOP

TEST 2.3:

Test the continuity from the motor A1 terminal to the frame on the motor and from F1 to A1 for open circuits.

Any reading other than an open circuit indicate a short in the motor. If there is a short in the motor, stop here and repair or replace the motor.

===== STOP =====



TEST 2.4:

Reaching this point indicates an open circuit in the motor wiring. Check the continuity of all wires from the controller to the motor.

Repair any open wires then test drive the vehicle.

Stop trouble shooting here and repair the problem. When the repair is completed, completely retest the vehicle before lowering the drive wheels to the ground.

⚠ WARNING

After any repairs are made, completely retest the vehicle before lowering the drive wheels to the ground. Failure to retest the vehicle could result in unexpected movement of the vehicle resulting in injury or property damage.

⚠ CAUTION

This troubleshooting guide is written in sequential order. All tests must be performed in the order that they are written. Starting in the middle or skipping sections when not instructed to do so may lead to invalid test results.

Test 3. THE VEHICLE RUNS IN ONE DIRECTION ONLY

Test 3.1:

Close the seat switch, turn the key switch ON and wait 1-second until the Isolator contactor closes.

If the vehicle runs in reverse only then skip ahead to test #3.3.

Place the forward and reverse switch in the FORWARD direction.

Test the voltage at pin #2 on the 12 pin logic card connector.

If the voltage is low, then skip ahead to test #3.2.

If the voltage is high, then skip ahead to Test #7.

TEST 3.2:

Test the voltage at pin #3 on the 12 pin logic card connector.

If the voltage is high, then skip ahead to test #3.3.

If the voltage is low, then skip ahead to Test #7.

TEST 3.3:

Place the forward and reverse switch in the REVERSE direction.

Test the voltage at pin #3 on the 12 pin logic card connector.

If the voltage is low, then skip ahead to test #3.4.

If the voltage is high, then skip ahead to Test #7.

TEST 3.4:

Test the voltage at pin #2 on the 12 pin logic card connector.

If the voltage is high, then it is likely that the internal directional control transistors have failed, test the transistors at Test 3.5 and 3.6. If the voltage is low, then skip ahead to Test #7.

TEST 3.5

Disconnect the batteries and remove wires from the B-, F1, and F2 terminals on the controller.

Using the diode test function on your meter, connect the positive lead to the B- terminal on the controller. Connect the negative lead to the F1 terminal on the controller.

The test should show the presence of a diode (approx 0.5v).

If the test is good, then skip ahead to test #3.6.

If the test is open or shorted then one or both directional FET's are shorted and the controller must be replaced.

TEST 3.6

Disconnect the batteries and remove wires from the B-, F1, and F2 terminals on the controller.

Using the diode test function on your meter, connect the positive lead to the B- terminal on the controller.

Connect the negative lead to the F2 terminal on the controller.

The test should show the presence of a diode (approx 0.5v). If the test is open or shorted then one or both directional FET's are shorted and the controller must be replaced.

==== STOP =====

Stop, do not continue. Reaching this point indicates a failure in the Sevcon power unit or an error was made during testing. Confirm all previous tests were performed correctly before replacing the Sevcon power unit.

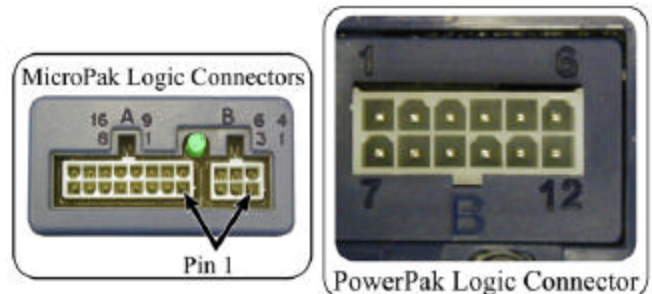

Test 4. KEY FAULT

TEST 4.1:

Turn the key switch ON and place the forward and reverse switch in the center OFF position

Perform the following tests:

Test the voltage at pin #1 on the 12 pin logic card connector.

If the voltage equals battery volts, then skip ahead to Test #5.

Test the voltage on both terminals of the battery voltage positive circuit breaker (see below).

If the voltage on both terminals equals battery volts, then skip ahead to test #4.2.

If the voltage on both terminals does not equal battery volts, then check the circuit breaker and wiring to the main circuit breaker and to the batteries for open circuits.

Stop trouble shooting here and repair the problem. When the repair is completed, completely retest the vehicle before lowering the drive wheels to the ground.

TEST 4.2:

Test the voltage at the hot terminal (red wire) on the key switch.

If the voltage equals battery volts, then skip ahead to test #4.3.

If the voltage does not equal battery volts, then check the wiring from the key switch to the battery voltage positive circuit breaker.

Stop trouble shooting here and repair the problem. When the repair is completed, completely retest the vehicle before lowering the drive wheels to the ground.



Typical Circuit Breaker

TEST 4.3:

Test the voltage at the cold side (violet/black wire) of the key switch.

If the voltage equals battery volts, then skip ahead to test #4.4.

If the voltage does not equal battery volts, then replace the key switch.

Stop trouble shooting here and repair the problem. When the repair is completed, completely retest the vehicle before lowering the drive wheels to the ground.

TEST 4.4:

Check the wire from the cold side of the key switch to pin #1 on the 12 pin logic card connector for open circuits.

NOTE: Your vehicle may be equipped with a charger interlock relay. The charger interlock relay disables the control system when the charger is connected to its power source. The interlock relay contacts are in series with the wire from the cold side of the key switch to pin #1 on the 12 pin logic card connector. The relay is located in the charger cabinet.

Stop trouble shooting here and repair the problem. When the repair is completed, completely retest the vehicle before lowering the drive wheels to the ground.

===== STOP =====

Stop, do not continue. Reaching this point indicates a failure in the Sevcon power unit or an error was made during testing. Confirm all previous tests were performed correctly before replacing the Sevcon power unit.

⚠ WARNING

After any repairs are made, completely retest the vehicle before lowering the drive wheels to the ground. Failure to retest the vehicle could result in unexpected movement of the vehicle resulting in injury or property damage.

Test 5. CONTACTOR COIL FAULT

Disconnect the 12-pin logic card connector from the Sevcon power unit.

Turn the key switch ON and perform the following tests:

TEST 5.1:

Check the voltage on the positive coil terminal of the ISO solenoid (violet wire).

If the voltage is within approximately 1-volt of the battery voltage, then skip ahead to test #5.2.

If the voltage is not within approximately 1-volt of the battery voltage, then check the diode in the positive wire to the ISO solenoid.

Stop trouble shooting here and repair the problem. When the repair is completed, completely retest the vehicle before lowering the drive wheels to the ground.



TEST 5.2:

Check the voltage on the negative coil terminal of the contactor coil.

If the voltage is not within 1-volt of battery voltage, then the contactor is bad and must be replaced.

NOTE: An open contactor coil should be accompanied by a 4-flash code from the logic LED.

If the voltage is within 1-volt, then one of the four following faults may have occurred:

Broken Wire: Check the wire from pin #8 in the 12-

pin logic card connector to the contactor coil negative terminal for open circuits.

Welded Solenoid Contacts: Test the solenoid for welded contact tips. There are two methods for checking the contacts:

1. Disconnect the batteries and test the continuity across the contacts. If there is continuity then the contact tips are welded.
2. With the key switch OFF, check the voltage at the B+ terminal on the Sevcon control (see illustration on following page). If the voltage at the B+ terminal is at full battery voltage then the contact tips are welded.

NOTE: Welded tips should be accompanied by a 4-flash code from the logic LED.

Shorted Solenoid Coil: Disconnect the logic card connector and measure the resistance across the solenoid coil. Depending on the solenoid or contactor your vehicle is equipped with, the resistance should be 25 ohms or higher (nominal). A reading less than 25 ohms may indicate a shorted coil.

The control logic may have failed.



===== STOP =====

Stop, do not continue. Reaching this point indicates a failure in the Sevcon power unit or an error was made during testing. Confirm all previous tests were performed correctly before replacing the Sevcon power unit.

Test 6. ACCELERATOR MODULE FAULT

⚠ WARNING

1. Make sure the key-switch is in the "OFF" position, then remove the key.
2. Place the forward-reverse switch in the center "OFF" position.
3. Set the park brake.
4. Place blocks under the front wheels to prevent vehicle movement.

⚠ WARNING

Disconnect both of the battery leads during any maintenance or before disconnecting any electrical component or wire. Failure to do so may cause property damage and/or serious bodily injury.

With the power switch OFF, connect the throttle module to the analyzer.

Position the power switch to the 0-5 volt range. All but the power lamp should be OFF. If the FS-1, FS-3 or OV lamp (Over Voltage) are ON, then the module is faulty.

Depress the lever on the module. The FS-1 lamp should be ON with no more that a few degrees of rotation. If the FS-1 lamp does not come on, then the module is faulty (see note below).

The voltage on the digital display should vary with the position of the module arm, starting at 0-volts and ending at approximately 5-volts.

If the OV lamp comes ON at any time, then the module is faulty.

If the Low battery lamp is ON, then the analyzer battery should be replaced.

Additional information regarding the analyzer can be found in the instructions provided with the analyzer (D0-110-53)



NOTE: Failures of the FS-1 circuit indicate a possible vehicle wiring fault that has resulted in a short circuit across FS-1. **BEFORE REPLACING THE MODULE:** Confirm that there are no shorts in the vehicle wiring or components. Installing a replacement module in a vehicle with faulty wiring will burn out the new module.

Test 7. FORWARD AND REVERSE SWITCH FAULT

Turn the key switch ON, place the forward and reverse switch in the center OFF position and perform the following tests:

TEST 7.1:

Referencing battery positive, test the voltage on the center terminal of the F&R switch (Black wire).

If the voltage equals battery volts, then skip ahead to test #7.2.

If the voltage does not equal battery volts, then check the wire from the F&R switch to the battery voltage circuit breaker.

Stop trouble shooting here and repair the problem. When the repair is completed, completely retest the vehicle before lowering the drive wheels to the ground.



TEST 7.2:

If the vehicle does not travel in reverse, skip ahead to test #7.3.

Place the forward and reverse switch in the FORWARD position.

Referencing battery positive, test the voltage at the Blue/Black wire on the F&R switch.

If the voltage equals battery volts, skip ahead to test #7.4.

If the voltage does not equal battery volts, then the F&R switch has failed.

Stop trouble shooting here and repair the problem. When the repair is completed, completely retest the vehicle before lowering the drive wheels to the ground.



⚠ CAUTION

This troubleshooting guide is written in sequential order. All tests must be performed in the order that they are written. Starting in the middle or skipping sections when not instructed to do so may lead to invalid test results.

⚠ WARNING

After any repairs are made, completely retest the vehicle before lowering the drive wheels to the ground. Failure to retest the vehicle could result in unexpected movement of the vehicle resulting in injury or property damage.

TEST 7.3:

If the vehicle does not travel in forward, skip ahead to test #7.4.

Place the forward and reverse switch in the REVERSE position.

Referencing battery positive, test the voltage at the White/Black wire on the F&R switch.

If the voltage equals battery volts, skip ahead to test #7.4.

If the voltage does not equal battery volts, then the F&R switch has failed.

Stop trouble shooting here and repair the problem. When the repair is completed, completely retest the vehicle before lowering the drive wheels to the ground.



TEST 7.4:

Check the wires from the F&R switch to the logic card connector for continuity.

===== STOP =====

Stop, do not continue. Reaching this point indicates a failure in the Sevcon power unit or an error was made during testing. Confirm all previous tests were performed correctly before replacing the Sevcon power unit.

⚠ WARNING

After any repairs are made, completely retest the vehicle before lowering the drive wheels to the ground. Failure to retest the vehicle could result in unexpected movement of the vehicle resulting in injury or property damage.

⚠ CAUTION

This troubleshooting guide is written in sequential order. All tests must be performed in the order that they are written. Starting in the middle or skipping sections when not instructed to do so may lead to invalid test results.



Test 8. ANTI-ROLLOFF FAULT

The Sevcon Controller is equipped with a feature called Anti-Rolloff. Anti-Rolloff will automatically slow the vehicle if it starts to roll. Anti-Rolloff is active when the key switch has been left in the “ON” position and the accelerator pedal is not depressed. Anti-Rolloff is deactivated when the key switch is in the “OFF” position. When the key switch is in the “ON” position and the truck is stationary, the controller supplies a small current to the field. This current is used to sense if the armature is rotating. As the armature begins to rotate, the controller senses a fault condition and then supplies current to the field opposing the armature rotation, slowing the vehicle.

Refer to Motor Specifications Table for information on the maximum allowable field current when the Anti-Rolloff feature is active.

To test the Anti-rolloff feature:

Park the vehicle on a flat level surface, turn the key switch OFF and apply the parking brake.

Connect an analog Ammeter in series with the motor field windings or a clamp on Ammeter on one of the field wires that is capable of reading up to 25-Amps.

Place the forward and reverse switch in the center OFF position and turn the key switch ON

TEST #8.1

Read the motor field current on the Ammeter.

If the field current is greater than specified in the Motor Specification table (see Motor Service section for specifications), then the Anti-Rolloff feature has failed. Check the status of the Anti-Rolloff feature using the hand held calibrator (62-027-61).

TEST #8.2

While monitoring the motor field current, release the park brake, and push the vehicle.

⚠ WARNING

The surface must be level for this test. Do not attempt to test the Anti-Rolloff by pushing up or down an incline. Testing by pushing up or down an incline could result in injury or property damage.

Within approximately 10-feet, the field current should rise dramatically and the vehicle should become difficult to push. Now stop pushing the vehicle and allow it to come to a complete stop.

The field current should drop down below the value specified in the Motor Specification table. This indicates that the Anti-Rolloff feature is operating normally.

If the current does not rise, then the Anti-Rolloff feature has failed or has been turned off.

The status of the Anti-Rolloff feature can be checked with the hand held calibrator.

If the Anti-Rolloff feature is on and the field current did not rise, then the controller has failed and must be replaced.

If the Anti-Rolloff feature is off then the controller logic must be reprogrammed. Contact your dealer.



Test 9. ELECTRIC MOTOR BRAKE

Description:

The electric motor brake is a 24-volt electromagnetic disc brake mounted between the drive motor and the primary reduction gear case. The brake is controlled by the speed controller logic. At what times the brake is applied or released is dependent on the controller programming and will vary depending on the model vehicle.

Operation:

B+ is supplied to the brake when the key switch is turned on. When the control logic determines that it is time to start, it provides B- at 24-volts through pin #9 on the logic card connector.

Testing:

Place the forward and reverse switch in the OFF position, turn the key switch OFF.

Rotate the drive wheels to confirm the brake is engaged.

If the brake is engaged then skip ahead to 9.1.

If the brake is not engaged then:

Disconnect the electric brake harness connector and repeat the test.

If the brake is still not engaged then:

- Remove the brake and repair or replace the brake as required. Stop trouble shooting here and repair the problem. When the repair is completed, completely retest the vehicle before lowering the drive wheels to the ground.

If the brake engaged after the harness was disconnected then:

Inspect the harness for shorts.

Stop troubleshooting here and repair the problem. When the repair is completed, completely retest the vehicle before lowering the drive wheels to the ground.

⚠ WARNING

The electric brake is part of the vehicle braking system. Do not operate a vehicle with the electric brake bypassed or disabled unless the system is being tested for faults. Operating a vehicle with the brake bypassed or disabled may result in severe personal injury or property damage.

Test 9.1

Close the seat switch, turn the key switch ON, place the forward and reverse switch in the FORWARD position, depress the accelerator pedal to engage FS-1 only (creep speed).

Rotate the drive wheels to confirm the brake has released.

If the brake released, then the brake system is working and no further testing of the brake is required.

If the brake did not release, then perform the following tests:

Connect a volt meter from battery negative to the Violet/Black wire at the electric brake harness plug.

If the voltage is less than battery volts then:

- Check wiring to the key switch and continue troubleshooting at test #4.2.

If the voltage equals battery volts then:

Connect a volt meter across the Violet/Black wire and the Blue wire at the electric brake harness plug. The voltage should start at approximately 24 volts, then drop to approximately 15 volts after about 0.5 seconds.

If the test is good then:

- The pigtail harness to the electric brake is broken or the electric brake has failed. Remove the brake and repair or replace as required.

If the test is bad then:

Connect a volt meter across the Violet/Black wire at the electric brake harness plug and Pin #9 at the logic card connector. The voltage should start at approximately 24 volts, then drop to approximately 15 volts after about 0.5 seconds.

If the test is good then:

- The blue wire from the electric brake harness plug to pin #9 on the logic card connector is broken. Stop trouble shooting here and repair the problem. When the repair is completed, completely retest the vehicle before lowering the drive wheels to the ground.

If the test is bad then:

- The logic card is not releasing the brake. This could be a result of:
 - Improper operation of the vehicle.
 - fault in the vehicles wiring or switches.
 - A fault in the speed controller.
 - Incorrect programming.
 - A failed speed controller.

Disconnect the electric brake harness connector and connect the electric brake to a 24-volt source. This should release the brake and allow you to troubleshoot the vehicles control system. Return to the beginning of the troubleshooting section and continue.

If the brake does not release then:

- The electric brake has failed. Remove the brake and repair or replace the brake as required. Stop trouble shooting here and repair the problem. When the repair is completed, completely retest the vehicle before lowering the drive wheels to the ground.

⚠ WARNING

After any repairs are made, completely retest the vehicle before lowering the drive wheels to the ground. Failure to retest the vehicle could result in unexpected movement of the vehicle resulting in injury or property damage.

⚠ CAUTION

This troubleshooting guide is written in sequential order. All tests must be performed in the order that they are written. Starting in the middle or skipping sections when not instructed to do so may lead to invalid test results.

Logic Voltage Reference Table

Pin#	Condition	Volts*
1	Key switch off	0.0 volts
	Key switch on	Battery volts
2	F&R in forward	Low
	F&R in neutral	High
	F&R in reverse	
3	F&R in reverse	Low
	F&R in neutral	High
	F&R in forward	
4	Accelerator pedal up	High
	Accelerator pedal down	Low
5	Seat switch closed (depressed)	Low
	Seat switch open	High
6	High/low switch in high	Low
	High/low Switch in low	High
7	Hand brake switch closed	Low
	Hand brake switch open	High
8	Key switch on (ref battery positive)	**
	Key switch off (ref battery positive)	Battery volts
9	System off (ref battery positive)	0 volts
	System on (ref battery positive)	**
10	Accelerator pedal up	0.0–0.3 volts
	Accelerator pedal down	4.8–5.0 volts
11	Not used	-
12	Not used	-

* - All voltages made referencing main negative unless specified otherwise

** - The voltage should start at approximately 24 volts, then drop to approximately 15 volts after about 0.5 seconds.

Status LED Code Table

The status LED on the Sevcon power unit logic card can be used to give you an idea of where the problem may be. It is recommended that you complete the troubleshooting procedure to confirm failure of any component.

Number of Flashes	Fault Description	Possible Cause	Actions
1	Personality fault	See dealer	-
2	Sequence fault	Startup switches not operated in the correct order	Reset the switches and start over (Refer to Vehicle Operating Instructions))
3	MOSFET or motor short	Burned Motor	Repair as required
4	Contactor fault or open motor	Contactor Failure Open Circuit	Check contactor and motor
5	Not used	-	-
6	Accelerator module fault	FS-1 Micro Switch Failure Faulty Wiring Accelerator Failure	Check accelerator module inputs
7	Discharged battery	Discharged battery or loose connections	Check battery and connections to controller
8	Controller overheated	Overloaded truck	Wait for controller to cool
9	ISO coil shorted	ISO Coil Short Circuit	Check coil continuity and replace as required
12	Can Buss Fault	Fault in the Wiring to the dash display or a faulty Dash Display NOTE: The Dash Display is Optional	Check wiring. If vehicle is not equipped with a dash display, check for debris in the 6-pin connector on the logic card

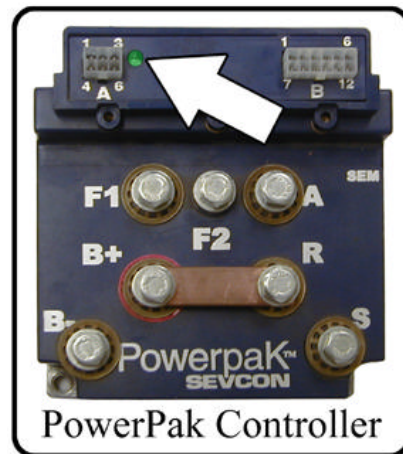



Smart View Fault Codes

Level 5 Faults (F05xxx)

F05000 “Contactor Over Current”

This fault occurs when too much current is going into the line contactor coil circuit. This could be a result of a shorted contactor coil, short in the wiring, or faulty logic card.

F05004: “VA Fail”

This is a result of a low voltage on an internal voltage regulator. Can also be caused by a low key switch input voltage. If the key switch input is within specifications, then replace the controller.

F05006: “MOSFET Short Circuit”

Also can be a result of an open motor armature circuit. Confirm the motor armature and wires to the motor are good. If motor and wires are good, then replace the controller.

F05008: “Power Up Traction Welded”

Normally due to line contactor welded closed resulting in a high voltage at B+. This fault is generated when the differential voltage between the key switch input and the B+ terminal is less than approximately 6-volts.

F05009: “Shorted MOSFET”

Normally due to internal short in controller. Also could be result of shorted motor or wiring. Remove the wire from the controller terminal “S”. If fault clears then the short is in the motor or wiring.

F05046: “Line Contactor Did Not Close”

Normally due to open circuit to the controller B+ terminal. Check wiring, contactor, main Circuit Breaker.
NOTE: Controller B+ terminal must be within 1.5 volts of Pin 1 after contactor closes.

All other level 5 faults are a result of an internal failure in the Sevcon controller and cannot be repaired. The controller must be replaced.

Level 4 Faults (F04xxx)

F04001: “Contactor Welded”

High voltage at power up to the controller B+ terminal. Check wiring, contactor, and pre-charge resistor on the contactor.

F04002: “Steer Pot”

Steer Pot currently not used and this fault should not occur. Check wiring.

F04003: “Sequence Fault”

Start-up switches not operated in the correct order or fault in start-up switches or wiring. Refer to operator section for correct operating sequence of switches.

F04004: “Two Directions Selected”

Both Forward and Reverse selected at the same time. Check F&R switch and wiring.

F04005: “SRO”

Start-up switches not operated in the correct order or fault in start-up switches or wiring. Refer to operator section for correct sequence of switches. Normally a result of F&R selected before start switch is turned on.

F04006: “Traction Seat”

Seat or foot interlock switch open. Check interlock switch, wiring.

F04007: “Inch Switch”

Inch switch ON at power up; both switches selected at same time; inching attempted with seat interlock, F&R switch, or FS-1 closed.

F04008: “Steer”

Steer Function currently not used and this fault should not occur. Check wiring.

F04009: “Low Battery”

Low voltage at Pin 1 of controller connector. Normally a result of discharged batteries. Check wiring, start switch, interlock switches, batteries.

F04010: “High Battery”

High voltage at Pin 1 of controller connector. Check for correct voltage battery installed, check controller parameters.

F04011: “Personality Range”

One or more controller personalities are out of range. Correct parameters must be uploaded to the controller.

F04012: “Personality CRC”

Controller personalities are corrupted. Could be a result of a damaged logic card. Attempt uploading new parameters. If upload fails, then controller must be replaced.

F04013: “Capacitor high”

Level 2 Faults (F02xxx)

- F02000: "Accelerator"
Wiring to throttle module is open or faulty throttle module.
- F02001: "Accelerator (power up)"
Throttle module FS-1 switch is closed (pedal depressed) or wiring shorted when start switch is turned on.
Throttle module output high when start switch is turned on.
- F02002: "Belly Switch"
Belly Switch currently not used and this fault should not occur. Check wiring.
- F02003: "Open Field"
Not used.
- F02004: "Open Field (L)"
Not used.
- F02005: "Open Field ((R))"
Not used.

Level 1 Faults (F01xxx)

- Most Level 1 faults are a result of operator error or operation of the vehicle.
- F01000: "Power Steer Overheat"
Not used.
- F01001: "Traction Motor Brush Wear"
Not used.
- F01002: "Pump Motor Brush Wear"
Not used.
- F01003: "Power Steer Motor Brush Wear"
Not used.
- F01004: "BDI Cutout"
Low voltage at Pin 1 of controller connector. Normally a result of discharged batteries. Check wiring, start switch, interlock switches, batteries. NOTE: Fault will not reset until batteries successfully complete a charge cycle and battery voltage is above reset threshold.
- F01005: "Traction Block Overheat"
Controller has overheated. Allow controller to cool off.
- F01006: "Traction Motor Hot"
Not used.
- F01007: "Pump Motor Hot"
Not used.
- F01008: "Encoder Wiring"
Motor speed encoder faulty, faulty wiring., or incorrect controller parameters.

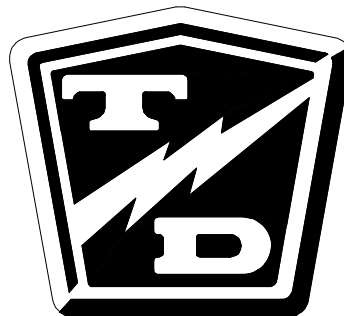

TAYLOR - DUNN

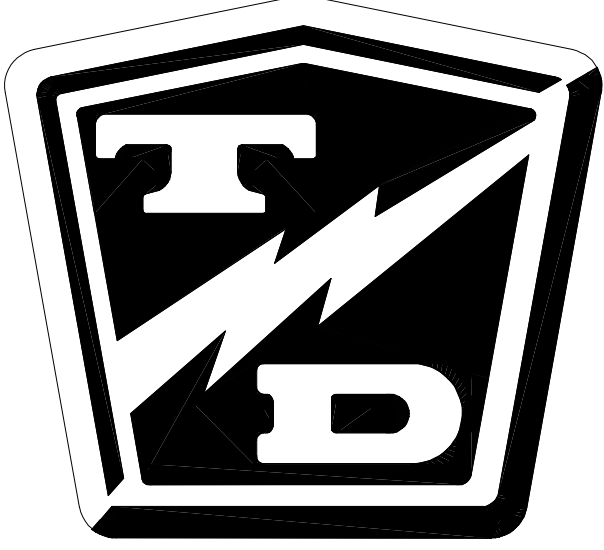

Lestronic II[®] Charger Troubleshooting

TABLE OF CONTENTS

Operating Instructions and Theory of Operation	2
Testing the Charging Cycle	3
Test Equipment Required for Troubleshooting	4
Important Notes and Instructions	4
Troubleshooting for Built-in Charger	5
Troubleshooting for Portable Charger	8
Testing The Timer Relay	9
Testing the Interlock Relay	10

⚠ CAUTION

Turn the Key switch **OFF** **BEFORE** disconnecting the batteries. Disconnecting the batteries with the key switch **ON** may corrupt the controller programming resulting in a fault code 1 (refer to fault table).



OPERATING INSTRUCTIONS AND THEORY OF OPERATION

The Lestronic II® chargers are designed as semiautomatic chargers. The Lestronic II® charger turns itself on when the “built-in” charger is plugged into the wall outlet, or when the “portable” charger is plugged into the batteries. As the battery charges, the battery voltage rises. The charger periodically checks the battery voltage and compares it to the previous reading. When the battery voltage stops rising a predetermined amount, then the batteries are no longer accepting a charge and the charger shuts off. The charger will not start again unless the AC cord on a “built-in” charger is disconnected from the wall outlet, or the DC plug on a portable charger is disconnected from the batteries.

The charger does not check the current state of charge when it is plugged in, it assumes that the batteries require charging when it is connected. For this reason, it is recommended to discharge the batteries approximately 50% (1175-1200 as indicated on a hydrometer) before connecting the charger. If the charger is connected before the batteries are discharged 50%, the batteries may enter an overcharge state before the charger can sense that the batteries are no longer accepting a charge. This could result in overcharging and damaging the batteries.

The relay that operates the charger is powered by the batteries being charged. If the voltage on the batteries to be charged is less than approximately 65% of the rated charger DC voltage, the relay will not pick up and the charger will not turn on. In this situation, a manual charger would have to be used to bring the battery voltage up so that the Lestronic® charger can sense that they are connected and turn itself on.

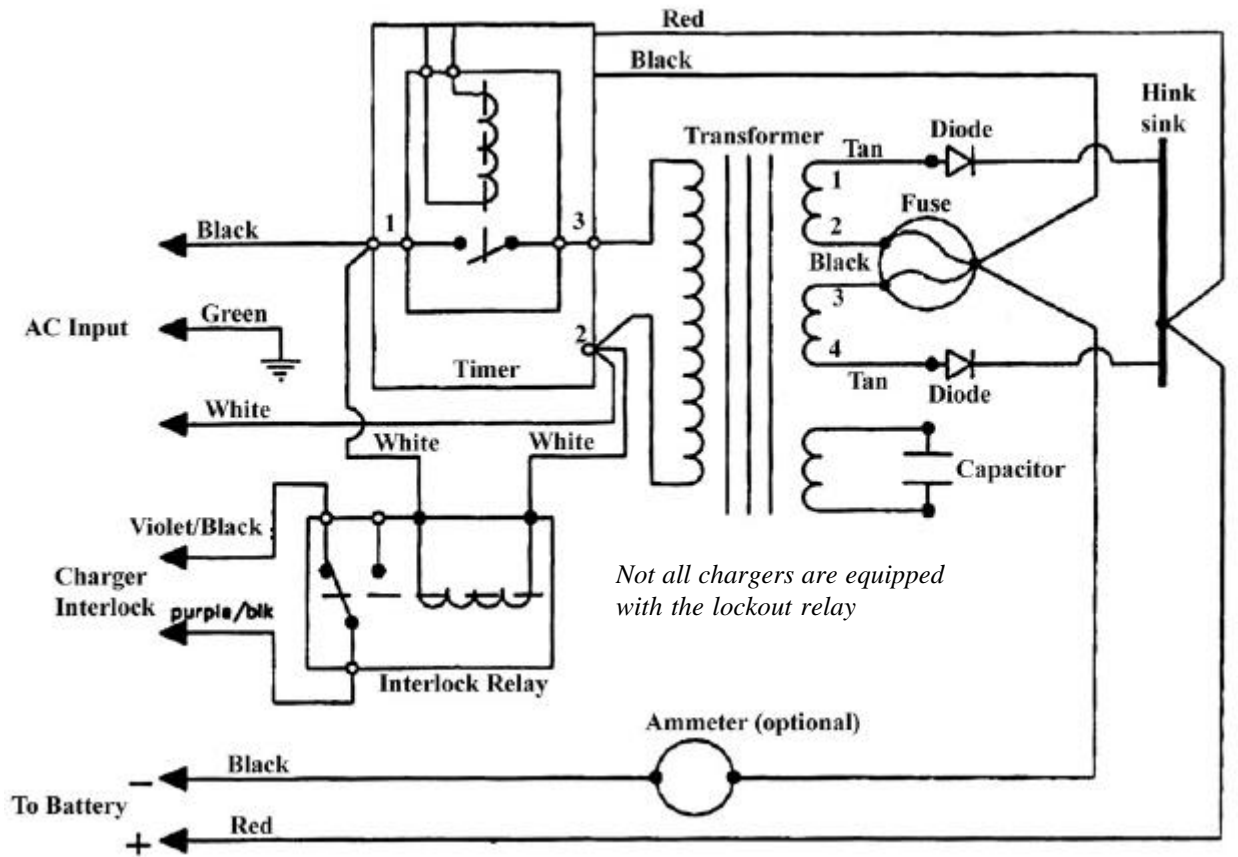

Typical Charger Internal Wire Diagram

TESTING THE CHARGING CYCLE

In typical installations, the charger will remain on for up to 12 hours depending on the state of charge of the battery when the charge cycle was started.

A charger could remain on for longer than 12 hours if:

- The charging cycle is interrupted at any time during the charging cycle.
- Defective batteries causing a fluctuating DC voltage that confuses the charger.
- A brownout (drop in AC line voltage) during the charging cycle.
- An electrically noisy charging environment.

A charger could turn off in less than 12 hours, but still show symptoms of overcharging if:

- The batteries were not discharged to 50% before connecting the charger.
- The electrolyte in the batteries is too high (boil over).
- The electrolyte in the batteries is too low (excessive gassing or sulfur smell).

To test the charger to see if it is turning off correctly, monitor the battery voltage and the electrolyte specific gravity during the charging cycle as indicated below.

Specific Gravity

Using a hydrometer take the specific gravity reading of several cells, at 1 hour intervals while charging. If the specific gravity of the electrolyte does not rise for three consecutive readings and the charger does not shut off, then the charger is running too long.

Battery Voltage

Using an accurate 5-1/2 digit digital voltmeter, monitor the battery voltage during the charging cycle. Take readings every 30 minutes. If the battery voltage does not increase 0.012 volts in two consecutive readings, then the charger is running too long.

TEST EQUIPMENT REQUIRED FOR TROUBLESHOOTING

Digital Multi Meter (DMM) with diode and capacitor test function, FLUKE 79® model shown at right and in the troubleshooting illustrations.



Important Notes and Instructions

- This troubleshooting guide assumes a familiarity with the use of a digital multimeter including, voltage tests, continuity tests and diode testing. If not familiar with any part of these tests, refer testing to a qualified technician.
- Make sure that the AC electrical socket the charger is plugged into is in good working condition.
- Make sure that the AC voltage at the electrical socket is the same as the AC voltage on the charger nameplate.
- Make sure the batteries are in good condition and no less than 80% discharged as per hydrometer reading.
- The battery voltage must be above approximately 65% of the chargers rated DC voltage. If the batteries are below approximately 65% of the chargers rated DC voltage, the charger will not turn on.
- If the charger exhibits intermittent problems, it must be in the failed mode for troubleshooting.
- Battery volts = Full voltage available at the batteries at the time of the test being performed.
- This test procedure must be performed in the order it was written. If starting in the middle or skipping sections when not instructed to do so, the proper results will not occur. If the test result is good, then proceed to the next test or go to the next section if instructed to do so.

During All Tests

WARNING

The charger cabinet must remain electrically grounded. Disconnect both of the battery leads and unplug the charger from the AC source before disconnecting any electrical component or wire. Failure to do so may result in serious bodily injury.

TROUBLESHOOTING FOR BUILT-IN CHARGER

WARNING

1. Make sure the key-switch is in the "OFF" position, then remove the key.
2. Place the forward-reverse switch in the center "OFF" position.
3. Set the park brake.
4. Place blocks under the front wheels to prevent vehicle movement.

5. Disconnect the charger from the AC source.

Locate the charger harness connectors where the charger harness is connected to the vehicle's control harness. There will be two 10 gauge and two 14 gauge wires.

Slide the insulators off the connectors on the two 10 gauge wires and perform the following tests:

CAUTION

Make sure that these two wires do not come into electrical contact with any other object.

6. Test the voltage from the red wire to the main battery negative. This voltage should be equal to the battery voltage. If the voltage is less than the battery voltage, then this wire is broken or has a bad connection. **Stop here and repair the problem.**
7. Test the voltage from the red 10 gauge wire (+) to the other 10 gauge wire (white or black depending on model). This voltage should be equal to the battery voltage. If the voltage is less than the battery voltage, then the white (or black) wire is broken or has a bad connection. **Stop here and repair the problem.**

Slide the insulators back onto the connectors on the two 10 gauge wires.

Slide the insulators off the connectors on the two 14 gauge wires.

WARNING

High Voltage. Do not touch the 14-gauge wires and make sure these two wires do not come into electrical contact with any other object. Failure to do so may result in serious bodily injury.

Re-Connect the charger to the AC source.

8. Test the voltage across the two 14 gauge wires. This voltage should be the same as the voltage at the AC receptacle (rated voltage of the charger). If the voltage is less than the rated AC voltage of the charger then the 14 gauge white or black wire(s) is broken or has a bad connection between the charger connectors and the AC plug. **Stop here and repair the problem.**

- Disconnect the charger from the AC source.
- Disconnect the batteries.
- Disconnect the charger from the vehicle's harness.
- Remove the charger from the vehicle.

WARNING

HIGH VOLTAGE may be stored in the capacitor. Discharge the capacitor before continuing. Connect a 2k ohm resistor across the capacitor terminals for 10 seconds. Do not touch the capacitor terminals with your hands. The resistor should be held with a pair of insulated pliers. Failure to do so may cause serious bodily injury

Remove the charger cover and perform the following tests:

1. Inspect the internal wiring of the charger and repair as required.
2. Check the continuity of both fuse links and replace if bad.
3. Disconnect one transformer lead from the capacitor. Test the capacitor using the capacitor test function of the meter. It is a 6 microfarad capacitor. If the capacitor is bad, it must be replaced. **Stop here and repair the problem.**

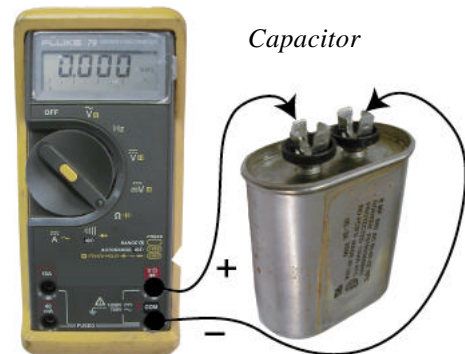
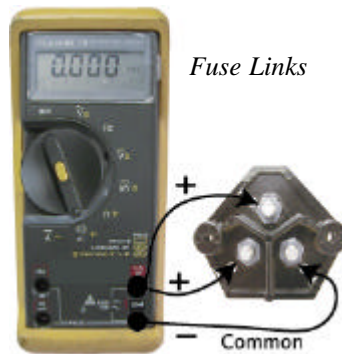

4. Reconnect the transformer lead to the capacitor and disconnect one transformer lead from one of the diodes. Test each of the diodes using the diode test function of your meter. If either one of the diodes are bad, replace the diode assembly. **Stop here and repair the problem.**
5. Reconnect the lead to the diode.
6. Reconnect the charger to the vehicle's harness and slide the wiring insulators back into place. Connect the charger to the AC source and perform the following tests:

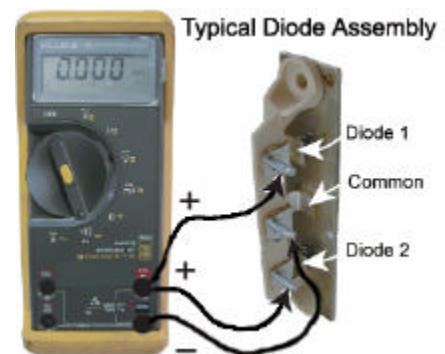

WARNING

High Voltage inside the charger. Do not touch any internal components while the charger is plugged in. Failure to do so may result in serious bodily injury.

- Test the voltage from the fuse assembly (-) to the diode block (+). This voltage should be equal to the battery voltage. If the voltage is less than the battery voltage, then the wires from the harness connectors to the charger are bad. **Stop here and repair the problem.**



- Test the voltage across the white and black wires that are connected to the timer board. This voltage should be the same as the rated AC voltage of the charger. If the voltage is less than the rated AC voltage of the charger, then the wires from the harness connectors to the charger are bad. **Stop here and repair the problem.**
- If the timer relay does not pickup (click) when the AC source is connected, then the timer control circuit or the relay is bad (refer to Timer Relay Test). **Stop here and repair the problem.**
- Test the AC voltage across the transformer primary circuit. The transformer primary consists of the two solid wires with the brown fiber insulator that are connected to the timer board. This voltage should be the same as the rated AC voltage of the charger. If the voltage is less than the rated AC voltage of the charger, then the timer relay is bad. **Stop here and repair the problem.**

- Test the AC voltage across the transformer low voltage secondary circuit. The transformer low voltage secondary circuit can be tested at the two solid wires with the brown fiber insulator that are connected to the anodes on the two diodes. The voltage here will vary depending on the state of charge in the batteries. The voltage should be between 208% and 250% of the rated DC voltage of the charger. If the voltage is not between 208% and 250% of the rated DC voltage of the charger, the transformer is bad and must be replaced. **Stop here and repair the problem.**



TROUBLESHOOTING FOR PORTABLE CHARGER

Disconnect the charger from the AC outlet and the batteries.

1. Test the voltage from the positive terminal on the vehicles DC receptacle to main battery negative. This voltage should be equal to the battery voltage. If the voltage is less than the battery voltage then this wire is broken or has a bad connection. **Stop here and repair the problem.**
2. Test the voltage from the positive terminal on the DC receptacle to the negative terminal on the DC receptacle. This voltage should be equal to the battery voltage. If the voltage is less than the battery voltage, then the wire on the negative terminal of the DC receptacle is broken or has a bad connection. **Stop here and repair the problem.**

Remove the charger cover and perform the following tests:

WARNING

HIGH VOLTAGE may be stored in the capacitor. **Discharge the capacitor before continuing. Connect a 2k ohm resistor across the capacitor terminals for 10 seconds. Do not touch the capacitor terminals with your hands. The resistor should be held with a pair of insulated pliers. Failure to do so may cause serious bodily injury**

1. Inspect the internal wiring of the charger and repair as required.
2. Check the continuity of both fuse links and replace if bad.
3. Disconnect one lead from the capacitor. Test the capacitor using the capacitor test function on the meter. If the capacitor is bad, it must be replaced. **Stop here and repair the problem.**

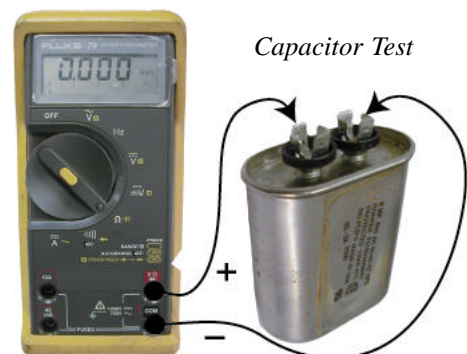

4. Reconnect the lead to the capacitor and disconnect one transformer lead from one of the diodes. Test each of the diodes using the diode test function on the meter. If either one of the diodes are bad, replace the diode assembly. **Stop here and repair the problem.**

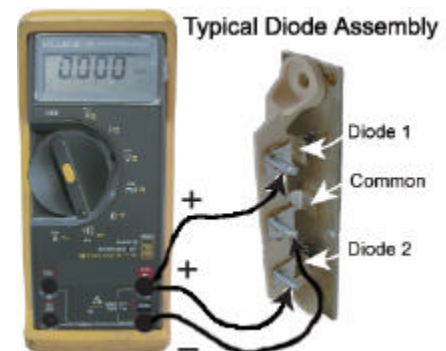



5. Reconnect the lead to the diode.
6. Connect the charger to the AC source. Insert the DC charger plug into the DC receptacle and perform the following tests:

WARNING

High Voltage inside the charger. Do not touch any internal components while the charger is plugged in. Failure to do so may result in serious bodily injury.

- Test the voltage from the fuse assembly (-) to the diode block (+). This voltage should be equal to the battery voltage. If the voltage is less than the battery voltage, then the DC cord is bad. **Stop here and repair the problem.**
- Test the voltage across the white and black wires that are connected to the timer board. This voltage should be the same as the rated AC voltage of the charger. If the voltage is less than the rated AC voltage of the charger then the AC cord is bad. **Stop here and repair the problem.**
- If the timer relay does not pickup (click) within 5 seconds of connecting the DC charger plug, then the timer control circuit or the relay is bad (refer to Timer Relay Test). **Stop here and repair the problem.**
- Test the AC voltage across the transformer primary circuit. This voltage should be the same as the rated AC voltage of the charger. If it is less than the rated AC voltage of the charger, then the timer relay is bad. **Stop here and repair the problem.**



Transformer Secondary Circuit

- Test the AC voltage across the transformer secondary circuit. The voltage here will vary depending on the state of charge in the batteries. The voltage should be between 208% and 250% of the rated DC voltage of the charger. If the voltage is not between 208% and 250% of the charge's rated DC voltage, the transformer is bad and must be replaced. **Stop here and repair the problem.**

TESTING THE TIMER RELAY

Test 1:

1. Connect the batteries to the charger.
 2. Plug the charger into the AC source.
 3. Wait 5 seconds, then test the voltage at the timer relay coil terminals.
NOTE: This voltage should be close to the battery volts.
- If the voltage is close to the battery volts, then skip to test 2.
 - If the voltage is not close to the battery volts, then the timer control circuit has failed and the timer must be replaced.

Test 2:

1. Disconnect the batteries.
2. Unplug the charger from the AC source.
3. Discharge the capacitor (see warning on previous page).



4. Disconnect the wires from the contact terminals on the timer relay.
 5. Reconnect the batteries.
 6. Wait 5 seconds, then test the continuity across the timer relay contact terminals.
- If this is a closed circuit, then the timer start up circuit is functioning normally.
 - If there is an open circuit, then the timer relay has failed and the relay must be replaced.

TESTING THE INTERLOCK RELAY

Operation

The Interlock Relay disables the vehicle from running whenever the charger is connected to a working AC power source. When the charger is plugged in, the relay contacts open and break the Key Switch connection to the speed controller. The Interlock Relay is available for built-in chargers only. Not all built-in chargers are equipped with this relay. To identify chargers that are equipped with the Interlock Relay:

Inspect the charger wire harness where it enters the charger cabinet for two Violet/Black wires. If these wires are present then the charger is equipped with the Interlock Relay.

Testing

⚠ WARNING

1. **Make sure the key-switch is in the "OFF" position, then remove the key.**
2. **Place the forward-reverse switch in the center "OFF" position.**
3. **Set the park brake.**
4. **Place blocks under the front wheels to prevent vehicle movement.**
5. **Disconnect the main positive and negative cables at the batteries.**

6. Disconnect the charger from the AC power source.
 7. Disconnect the two Violet/Black wires at the charger harness knife connectors.
 8. Set the DMM to check for continuity and connect the DMM leads to the wires going into the charger.
 - The DMM should indicate a closed circuit. If the DMM indicates an open circuit, then the relay or the wires to the relay have failed. **Stop here and repair the problem.**
 9. Connect the charger to a working AC power source.
 - The charger should turn on. If the charger does not turn on then there may be a problem with the AC power source or the AC wiring to the charger. Refer to the beginning of this section for charger troubleshooting. **DO NOT** continue until you have confirmed that the AC power source is working.
 - The DMM should indicate an open circuit. If it still indicates a closed circuit, then the relay or the wires to the relay have failed. **Stop here and repair the problem.**
- If the DMM indicates an open circuit then the interlock relay is functioning normally.

signet® Charger Troubleshooting

TABLE OF CONTENTS

Operating Instructions and Theory of Operation	2
HB/PT and GEL Indicator Lamps	3
Testing the Charging Cycle	3
Test Equipment Required for Troubleshooting	4
Important Notes and Instructions	4
Status LED Error Code Table	5
Troubleshooting	6

⚠ CAUTION

Turn the Key switch OFF **BEFORE** disconnecting the batteries. Disconnecting the batteries with the key switch ON may corrupt the controller programming resulting in a fault code 1 (refer to fault table).



OPERATING INSTRUCTIONS AND THEORY OF OPERATION

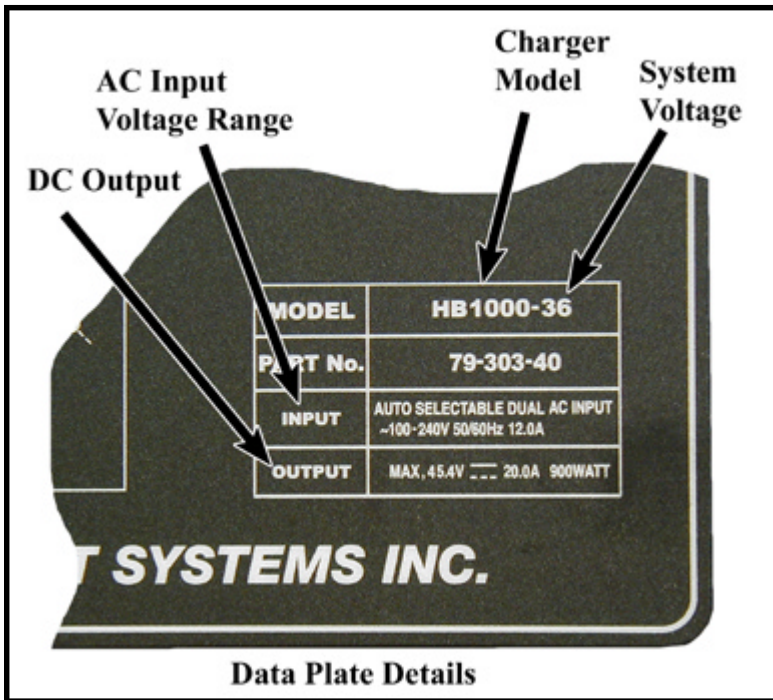

The model HB600W® and HB1000W® chargers are designed as semiautomatic chargers. The charger turns itself on when it is plugged into the wall outlet and turns off when the batteries are fully charged.

Both the HB600W® and HB1000W® are two stage chargers. The first stage is a constant current mode. It maintains a constant current until the battery reaches a terminal voltage and then switches to the second stage, constant voltage. At the second stage the charger decreases the charger current while holding the batteries at the terminal voltage until the charging cycle is complete.

The charger faceplate has three status LED's that monitor the charging status. Refer to the chart and illustration below for the function of these LED's.

If an error occurs during charging, the charger will beep, and display an error code by flashing the status LED's. Refer to the Status LED error code table later in this section.

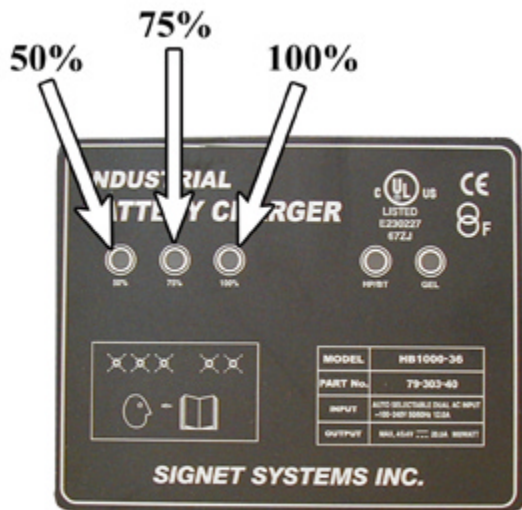

Typical Charger Data Plate
(your data plate may vary)

Charging Status	Left (50%)	Middle (75%)	Right (100%)
0-50%	FLASHING	OFF	OFF
50% - 75%	ON	FLASHING	OFF
75% - 100%	ON	ON	FLASHING
Charging Cycle complete	ON	ON	ON
Error, refer to troubleshooting	FLASHING	FLASHING	FLASHING
Charger Time Out	OFF	OFF	FLASHING

HB/PT AND GEL INDICATOR LAMPS

NOTE: Your charger may not be equipped with these lamps.

HB/PT Lamp

If the HB/PT lamp is “ON”, then the charger has overheated and has entered a proportionally reduced output. The charging cycle will terminate if the temperature continues to rise. If the charging cycle is terminated, the charger will automatically restart once it has cooled.

The charging cycle is limited to 18-hours. If the HB/PT lamp is flashing, then the charging time has exceeded 18-hours (time is limited to 18-hours). If any of the status lamps are flashing, then the charge cycle did not complete.

GEL lamp

This LED will only be “ON” if the charger is configured for GEL batteries. Using a GEL charger with non-GEL batteries may result in an incomplete charge or long charge times.

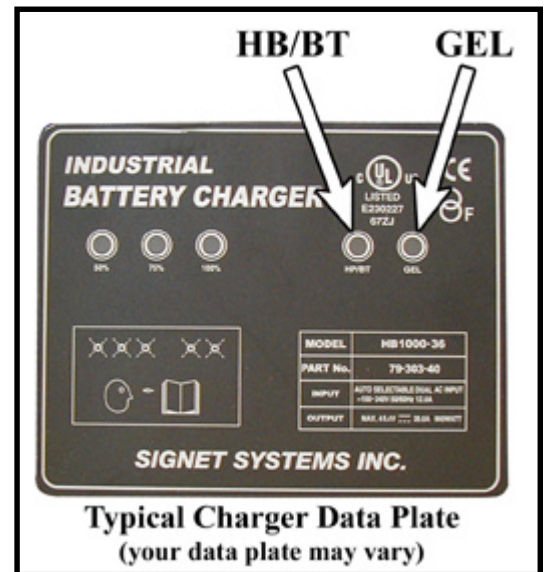

CAUTION

GEL batteries must be charged with a charger configured for GEL batteries. Use of any other charger will result in damage to the batteries and premature failure of the batteries.

TESTING THE CHARGING CYCLE

In typical installations, the charger will remain on for up to 12 hours depending on the state of charge of the batteries when the charge cycle was started.

NOTE: Charging time is limited to 18-hours (max). An error occurs if charging time exceeds 18-hours. See table on previous page.

A charger could remain on for longer than 12 hours if:

- The vehicle is equipped with batteries larger than 220 Amp hour capacity.
- The charging cycle is interrupted at any time during the charging cycle.
- Defective batteries causing a fluctuating DC voltage that confuses the charger.
- One or more defective cells in the battery pack.
- A brownout (drop in AC line voltage) during the charging cycle.
- An electrically noisy charging environment.

A charger could turn off in less than 12 hours, but still show symptoms of overcharging if:

- The electrolyte in the batteries is too high (boil over).
- The electrolyte in the batteries is too low (excessive gassing or sulfur smell).

To test the charger to see if it is turning off correctly, monitor the battery voltage and charging current during the charging cycle as indicated below.

Using a digit digital voltmeter and clamp on DC ammeter, monitor the battery voltage and current during the charging cycle. The charging current should remain within 10% of the DC output current (see previous page) until the battery voltage reaches 2.55 volts per cell. When the voltage reaches 2.55 volts per cell, the charging current will drop significantly and slowly taper off (voltage will remain constant). The charger should turn off within 2 to 4 hours after entering the second stage.

TEST EQUIPMENT REQUIRED FOR TROUBLESHOOTING

Digital Multi Meter (DMM), FLUKE 79® model shown at right and in the troubleshooting illustrations.

Clamp on DC ammeter to measure up to 20-Amps.



Important Notes and Instructions

- This troubleshooting guide assumes a familiarity with the use of a digital multimeter including, voltage tests, continuity tests and diode testing. If not familiar with any part of these tests, refer testing to a qualified technician.
- Make sure that the AC electrical socket the charger is plugged into is in good working condition.
- Make sure that the AC voltage at the electrical socket is the same as the AC voltage on the charger nameplate.
- Make sure the batteries are in good condition.
- If the charger exhibits intermittent problems, it must be in the failed mode for troubleshooting.
- Battery volts = Full voltage available at the batteries at the time of the test being performed.
- There are no internally serviceable components in the charger. If the charger has failed then it must be replaced.

⚠ CAUTION

This charger is rated for 115 VAC or 230 VAC operation. When switching from one input voltage to the other, wait until all three status LED's are off. Switching voltage when any of the LED's are on will result in damage to the charger.



STATUS LED ERROR CODE TABLE

There are three status lights (LED's) on the charger name plate. These LED's normally indicate the current operating state of the charger. If all three LED's are flashing, it indicate an error has occurred in the charging cycle. See the table below for an explanation of the error codes:

Note: If only the 100% LED is flashing and all others are OFF then the charger has exceeded its maximum charging time and shut off before the batteries were fully charged.

This could be a result of:

- Defective battery or batteries
- Excessively discharged batteries
- Oversize batteries

Error Code	Description	Action Required
1*	Reverse polarity or open circuit to the batteries	Check wiring for corrosion, loose connections, broken wires and proper connection to the batteries
2	AC line voltate too high or too low	Check the input voltage. It must be within 96-132VAC or 196-266VAC
3	Charger overheated	Wait for charger to cool, the charger will automatically restart. Inspect for dirt or debris on the charger cooling fins and clean as required.
4	Input or Output over current	Charger will automatically correct for this condition and restart

* - In many cases fault 1 will only be displayed for a short amount of time and then the charger will attempt to restart. Typically, the fault will repeat 8-times and then the charger will start the boot up process with the 50% light on. If the charger cannot restart then the fault loop will start again, repeating the fault 1.

This fault could be a result of an open connection between the charger and batteries, an open connection on one or more of the battery cables, or an open connection internal of the charger.

Before replacing the charger, confirm all battery wiring is good.

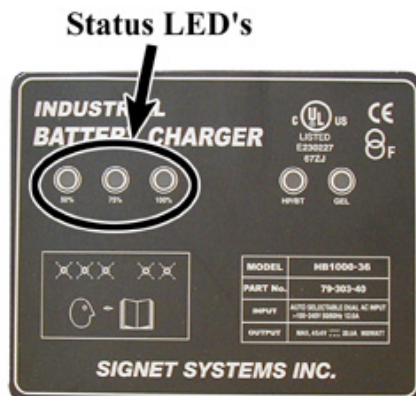

Typical Charger Data Plate
(your data plate may vary)

TROUBLESHOOTING

To test charger operation:

Connect a DC volt meter to the main battery positive and negative terminals.

Attach a clamp on DC Ammeter to one of the charger DC output wires.

Plug the charger into an AC outlet.

Wait for charger to start (up to 15 seconds), the ammeter should display the DC Amp rating of the charger (plus or minus 10%) indicating that the charger is on (constant current mode).

The ammeter should continue to display the DC Amp rating of the charger until the battery voltage equals 2.55 VPC. When the battery voltage equals 2.55 VPC the charger will switch to the constant voltage mode. At this point the charging current will be reduced and will taper off until the batteries are fully charged.

Perform the following if the charger does not turn on:

WARNING

1. **Make sure the key-switch is in the "OFF" position, then remove the key.**
2. **Place the forward-reverse switch in the center "OFF" position.**
3. **Set the park brake.**
4. **Place blocks under the front wheels to prevent vehicle movement.**

5. Disconnect the charger from the AC source.
6. Remove the charger end cap where the DC wires enter.
7. Test the voltage across the Battery Positive (red) and Battery Negative (black) wires at the lower left of the charger circuit board. This voltage should be equal to the battery voltage. If the voltage is less than the battery voltage, then the wires to the batteries have been damaged. **Stop here and repair the problem.**
8. Reinstall the charger end cap where the DC wires enter.
9. Remove the charger end cap where the AC wires enter.
10. Test the continuity of all three AC wires from the circuit board to the AC plug. If you find an open circuit in any one of the three wires then the AC cord or plug has been damaged. **Stop here and repair the problem.**
11. Install the charger end cap where the AC wires enter.

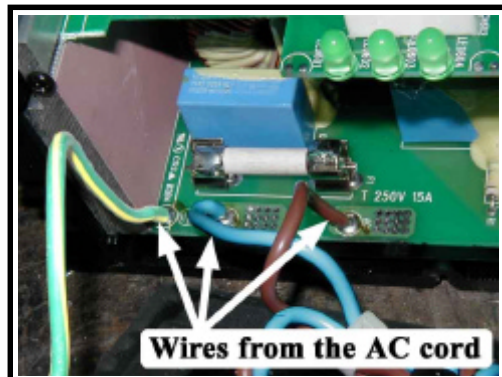
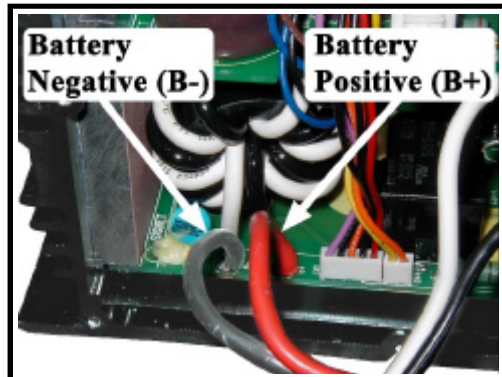

If both the AC and DC tests are good then the charger has failed. There are no internally serviceable components in the charger. If the charger has failed then it must be replaced.

Signet® Charger Troubleshooting

Charger Models:

HBS 600

HBS 1000

TABLE OF CONTENTS

Definitions:	2
Test Equipment Required for Troubleshooting	2
Important Notes and Instructions	2
Operating Instructions and Theory of Operation	3
Testing the Charging Cycle	4
Status Light Error Code Table	5
Troubleshooting	6

⚠ CAUTION

Turn the Key switch **OFF** **BEFORE** disconnecting the batteries. Disconnecting the batteries with the key switch **ON** may corrupt the controller programming resulting in a fault code 1 (refer to fault table).

⚠ CAUTION

GEL batteries must be charged with a charger configured for GEL batteries. Use of any other charger will result in damage to the batteries and premature failure of the batteries.



DEFINITIONS:

Volts Per Cell = Voltage for each cell in a battery pack. for example, one 6-volt battery has 3-cells.

Term	Value	Condition
V1:	See Chart 2.383 Volts Per Cell	Flooded batteries Gel Batteries
V2:	2.08 Volts Per Cell	All batteries
A1:	2 to 4 Amps	All batteries

All voltages are nominal.

V1: Voltages are temperature compensated relative to the temperature of the charger at the time the charge cycle is started.

Starting Temperature (C)	V1 Volts Per Cell
Less than -4	2.64
-4 to 2	2.61
2 to 8	2.59
8 to 14	2.56
14 to 21	2.54

⚠ CAUTION

This charger is rated for 115 VAC or 230 VAC operation (nominal). When switching from one input voltage to the other, wait until all LED's are off. Switching voltage when any of the LED's are on will result in damage to the charger.

⚠ CAUTION

GEL batteries must be charged with a charger configured for GEL batteries. Use of any other charger will result in damage to the batteries and premature failure of the batteries.

TEST EQUIPMENT REQUIRED FOR TROUBLESHOOTING

Digital Multi Meter (DMM), calibrated and accurate down to 0.00001 volts.

Clamp on DC ammeter to measure up to 20-Amps.

Important Notes and Instructions

- This troubleshooting guide assumes a familiarity with the use of a digital multimeter including, voltage tests, continuity tests and diode testing. If not familiar with any part of these tests, refer testing to a qualified technician.
- Make sure that the AC electrical socket the charger is plugged into is in good working condition.
- Make sure that the AC voltage at the electrical socket is the same as the AC voltage on the charger nameplate.
- Make sure the batteries are in good condition.
- If the charger exhibits intermittent problems, it must be in the failed mode for troubleshooting.
- There are no internally serviceable components in the charger. If the charger has failed then it must be replaced.

OPERATING INSTRUCTIONS AND THEORY OF OPERATION

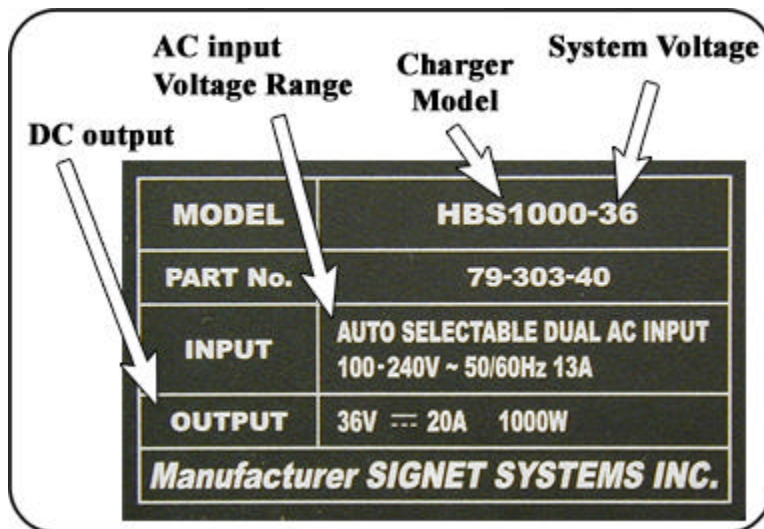

*Typical specification plate
(reference only, specifications will vary for different chargers)*

The model HBS 600W[®] and HBS 1000W[®] chargers are designed as automatic chargers. The charger turns itself on when it is plugged into the wall outlet and turns off when the batteries are fully charged. Once the charging cycle is complete, the charger will monitor the battery voltage. If the battery voltage drops below a specific value (V2), the charger will turn on again for a short cycle.

Both the HBS 600W[®] and HBS 1000W[®] are two stage chargers. The first stage is a constant current mode. It maintains a constant current until the battery reaches a terminal voltage (V1) and then switches to the second stage, constant voltage. At the second stage the charger decreases the charger current while holding the batteries at the terminal voltage until the charging cycle is complete. The charging cycle is complete when the current is down to A1

On the charger face plate, there is a status light panel that displays the current status of the charger.

The first light (**POWER**) should be ON when the AC cord is connected to a proper AC power source.

The three **STATUS** lights will indicate the current charging condition as follows:

Left: Charge cycle is ON and is in constant current mode.

Left & Middle (80%): Charge cycle is ON and is in constant voltage mode.

Right (100%): Charge cycle completed.

The **FAULT** light will turn ON and flash a fault code only when an abnormal charging condition has occurred. Refer to the fault code table for more information.

NOTE: Critical faults will be accompanied with an audible beeping.

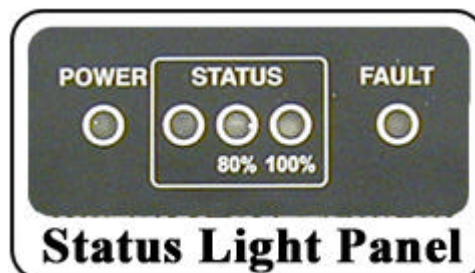

TESTING THE CHARGING CYCLE

In typical installations, The charge cycle will be completed in 8 to 12 hours depending on the state of charge of the batteries when the charge cycle was started.

NOTE: The charge cycle time is limited to 20-hours (max). A fault will occur if charging time exceeds the time limit. Refer to the fault code table for more information.

A charger could remain on for longer than 12 hours if:

- The vehicle is equipped with batteries larger than 220 Amp hour capacity.
- The charging cycle is interrupted at any time during the charging cycle.
- Defective batteries causing a fluctuating DC voltage that confuses the charger.
- One or more defective cells in the battery pack.
- A brownout (drop in AC line voltage) during the charging cycle.
- An electrically noisy charging environment.

NOTE: This charger has a maintenance mode that will restart the charger if the battery voltage drops below a threshold after the charge cycle is complete. In some cases, it may appear that the charger is not turning off due to that the charger has restarted. Fully test the battery pack before assuming that the charger is not turning off or running too long.

A charger could turn off in less than 12 hours, but still show symptoms of overcharging if:

- The electrolyte in the batteries is too high (boil over).
- The electrolyte in the batteries is too low (excessive gassing or sulfur smell).

To test the charger to see if it is turning off correctly, monitor the battery voltage and charging current during the charging cycle as indicated below.

Using a digital voltmeter and clamp on DC ammeter, monitor the battery voltage and current during the charging cycle. The charging current should remain within 10% of the DC output current (see previous page) until the battery voltage reaches V1. When the voltage reaches V1, the charging current will drop significantly and slowly taper off (voltage will remain constant). The charger should turn off within 2 to 4 hours after entering the second stage when the charging current is down to A1.

⚠ CAUTION

GEL batteries must be charged with a charger configured for GEL batteries. Use of any other charger will result in damage to the batteries and premature failure of the batteries.



STATUS LIGHT ERROR CODE TABLE

If the Fault light is ON or flashing, it indicates a problem has occurred during the charging cycle. If the light is flashing, it will flash from 2 to 6 times before a pause. This is the fault code.

Refer to the table below.

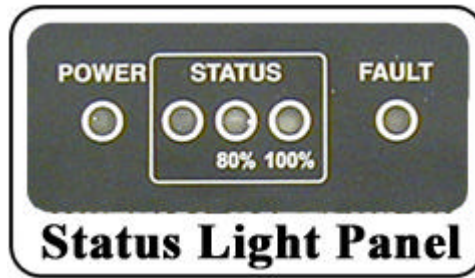

Fault Code	Description	Action Required
1 (no flash)	Time out	Charge cycle time exceeded the time limit. Test batteries for possible defective cells.
2*	Open circuit or reverse polarity to battery	Check battery wiring.
3*	Battery voltage too high	Wrong voltage charger or batteries installed. 24v charger: Battery voltage must be less than 33.7v 36v charger: Battery voltage must be less than 43.2v 48v charger: Battery voltage must be less than 57.6v
4	Overheated	Inspect for dirt or debris on the charger cooling fins and clean as required.
5*	AC line voltage too high or too low	Check the input voltage. It must be within 85-137VAC or 170-264VAC
6	Low battery voltage	Extremely discharged battery, defective battery, miswired battery. When this fault occurs, the charger will operate in a low current mode until the battery voltage is built up. This fault will reset once the battery voltage is normal. If the battery voltage does not come up: > Test the batteries > Check battery wiring
*	These faults will be accompanied by an audible beep and indicates that the charge cycle was terminated before completion.	

TROUBLESHOOTING

NOTE: There are no internally serviceable components in the charger.

To test charger operation:

Connect a DC volt meter to the main battery positive and negative terminals.

Attach a clamp on DC Ammeter to one of the charger DC output wires.

Plug the charger into an AC outlet.

Wait for charger to start (up to 15 seconds), the ammeter should display the DC Amp rating of the charger (plus or minus 10%) indicating that the charger is on (constant current mode).

The ammeter should continue to display the DC Amp rating of the charger until the battery voltage equals V1. When the battery voltage equals V1 the charger will switch to the constant voltage mode. At this point, the charging current will be reduced and will taper off until the batteries are fully charged. The batteries are fully charged when the charging current is down to A1.

If the charger does not turn on, there are no faults, and the POWER light is ON, then the charger has failed and must be replaced.

If the POWER light is OFF, then check the AC power source, AC power cable and connections. If the source, cable and connections are good, then the charger has failed and must be replaced.

The charger comes equipped with a long fully insulated AC cord that can be cut to length as needed for the vehicle application. Do not cut the AC cord and splice to the existing AC cord in the vehicle. **Cutting and splicing the AC cord will void the charger warranty**

⚠ CAUTION

GEL batteries must be charged with a charger configured for GEL batteries. Use of any other charger will result in damage to the batteries and premature failure of the batteries.



Wire Diagrams

TABLE OF CONTENTS

Complete Vehicle	2
Dash	3
Control Panel	4
Accelerator Module Detail	5
Lighting	6
Trailer Brake Module and Receptacle.....	7
Hydraulic Dump Option	8

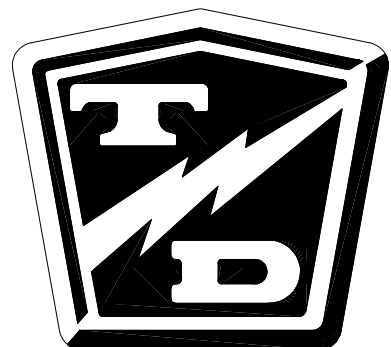

COMPLETE VEHICLE

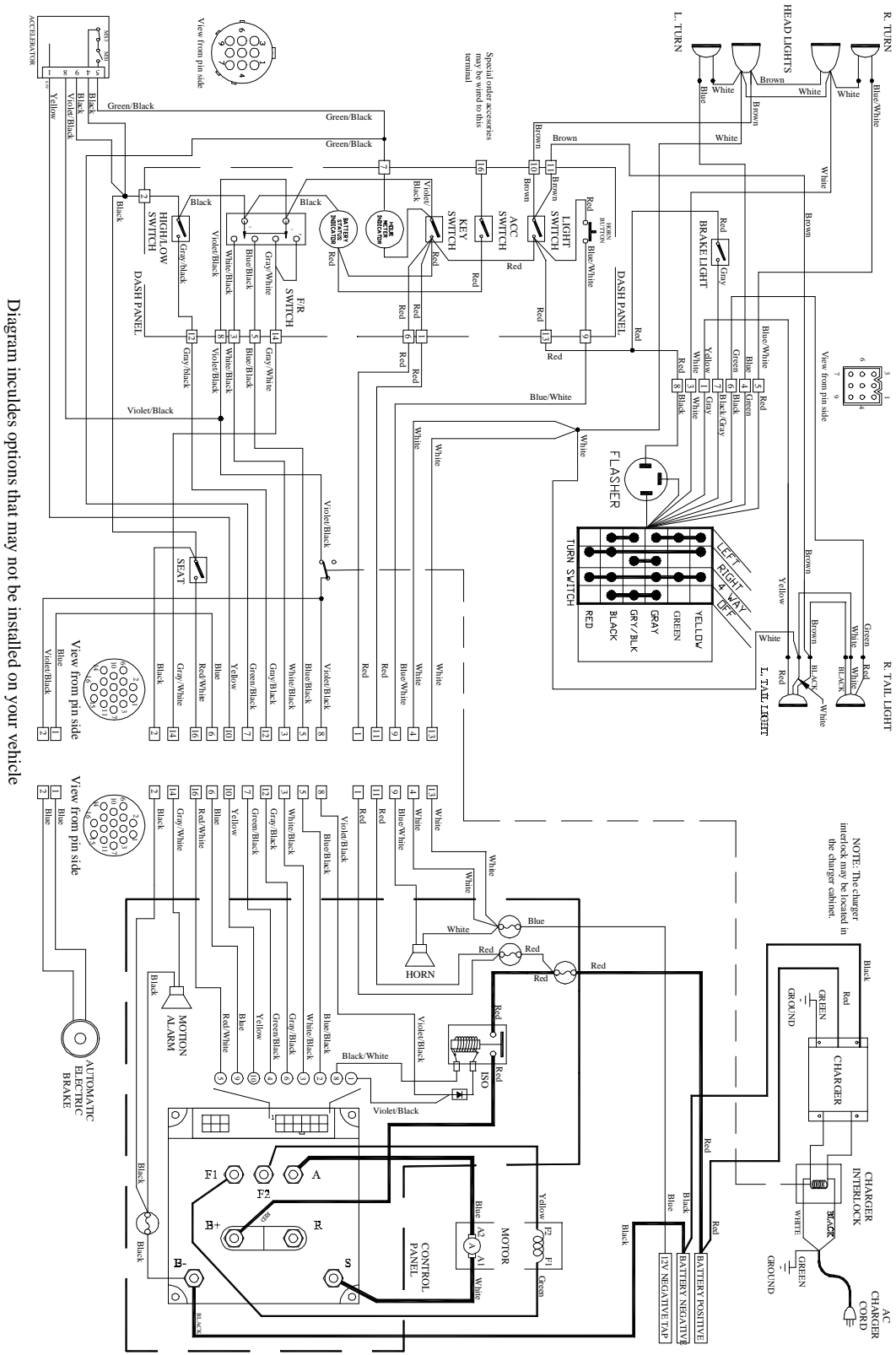

DASH

Special order accessories may be wired to this terminal

Harness Connector

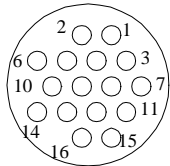

View from pin side

F&R Switch

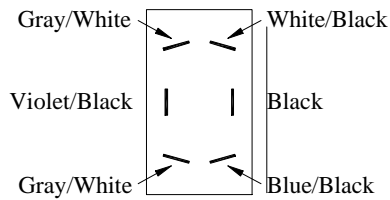
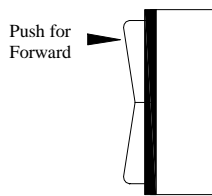

View from Rear

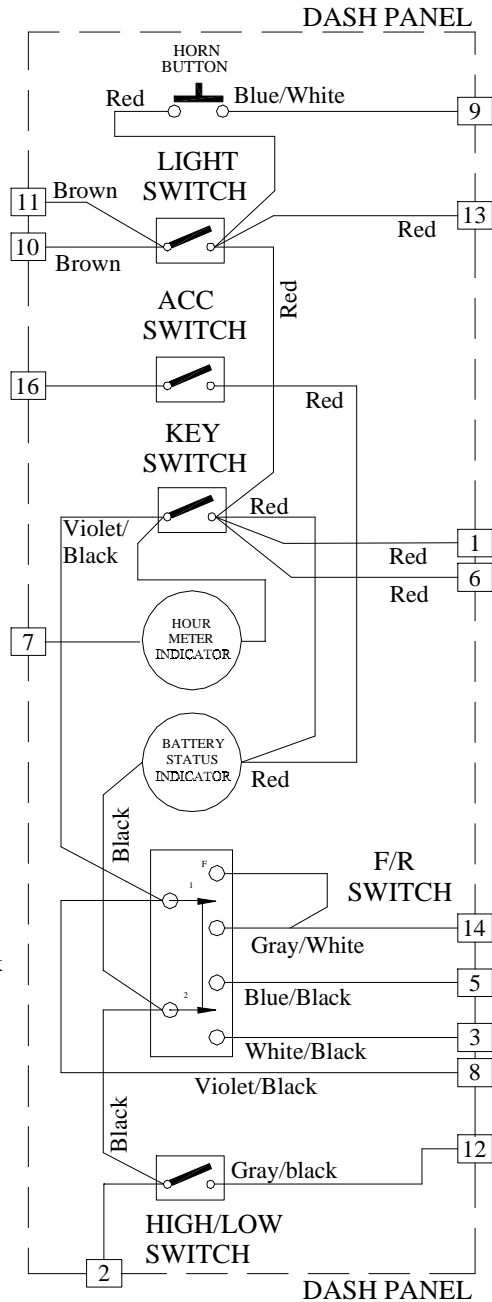

ACCELERATOR MODULE DETAIL

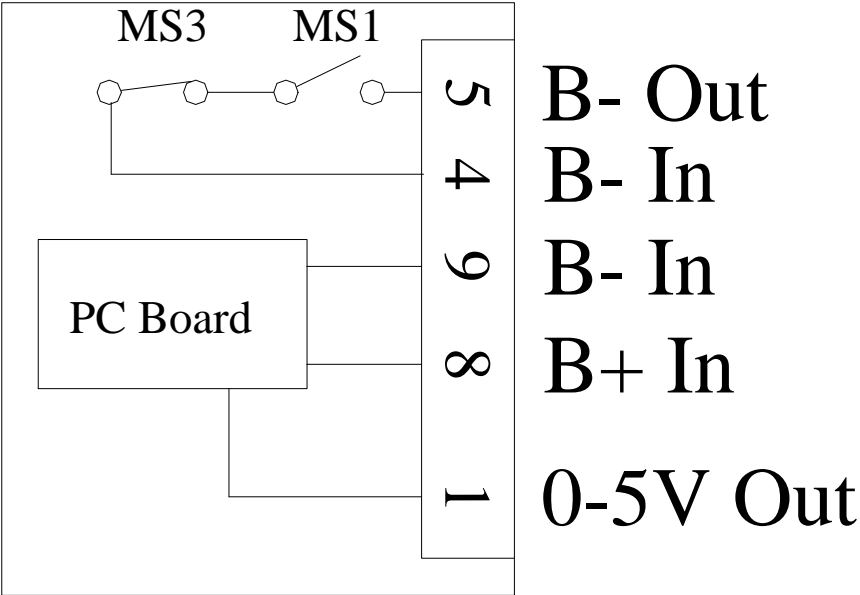

ACCELERATOR

LIGHTING

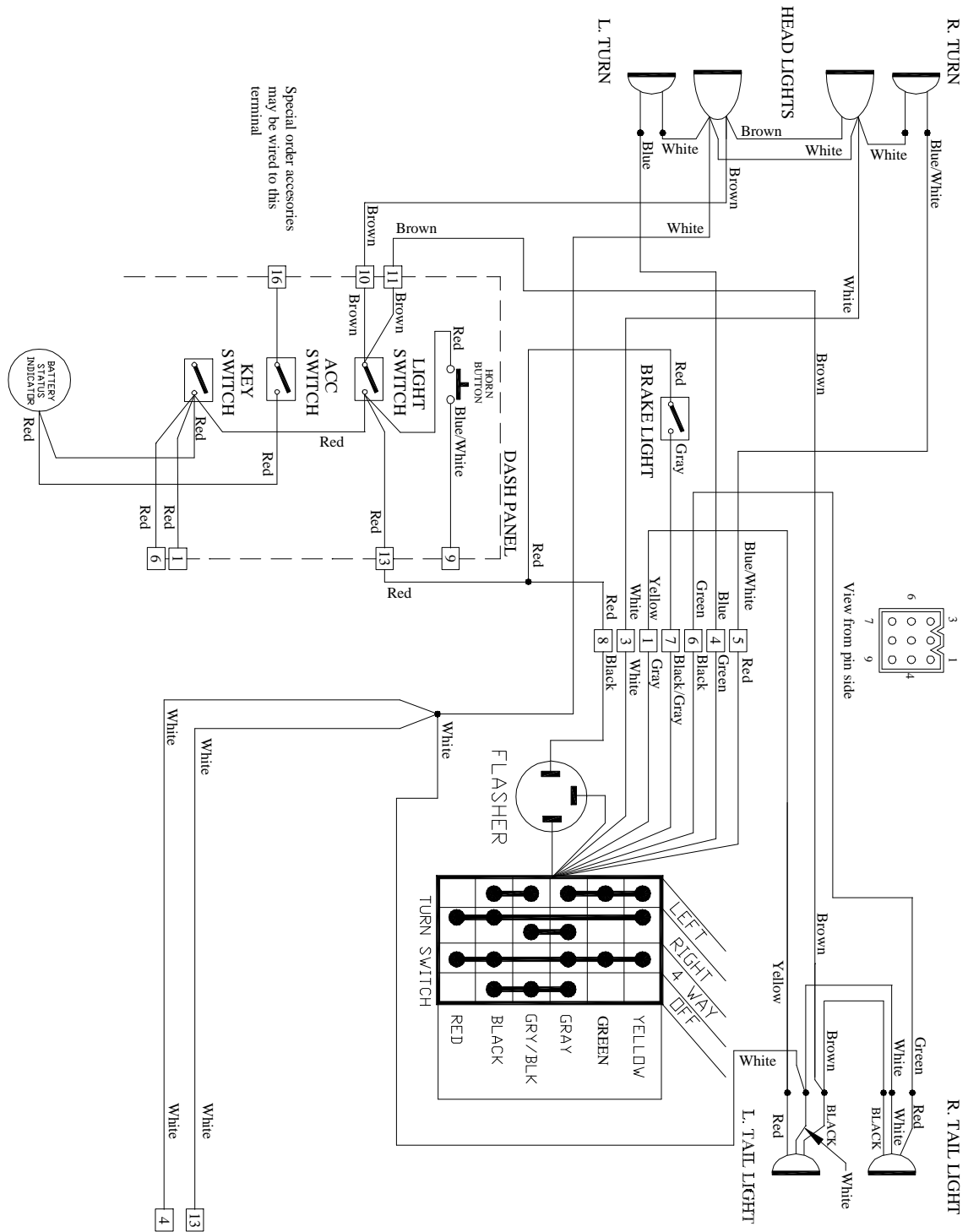

TRAILER BRAKE MODULE AND RECEPTACLE

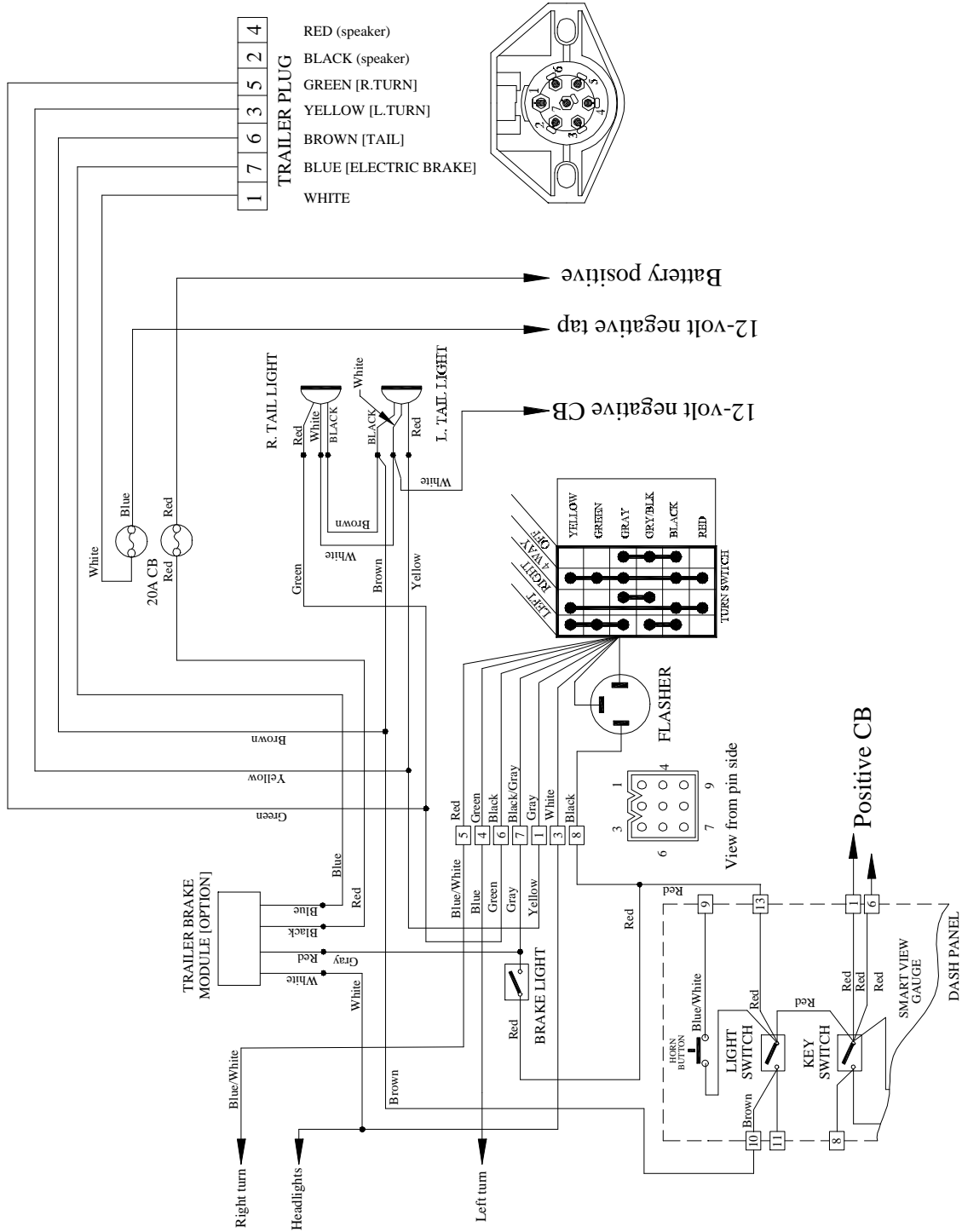

HYDRAULIC DUMP OPTION

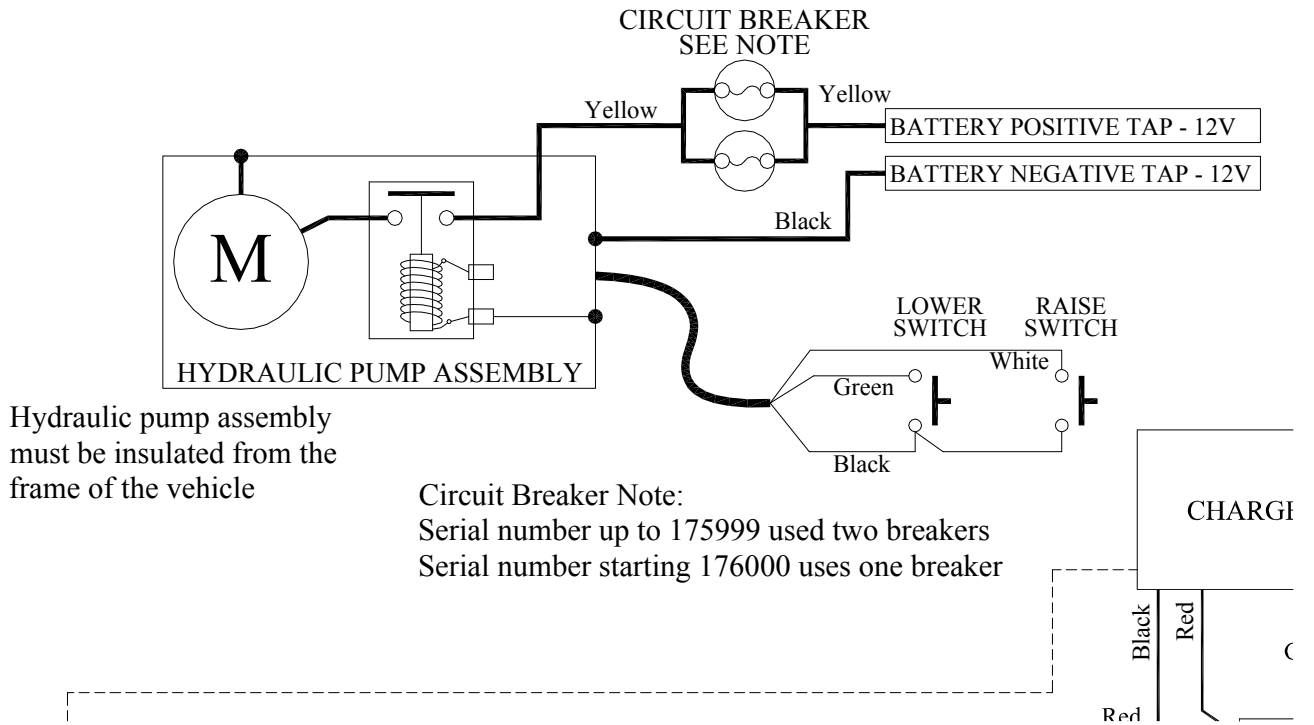

Illustrated Parts

TABLE OF CONTENTS

Front Axle	2	Wheels and Tires	36
Steering Knuckle	4	Instrument Panel (dash)	38
Front Brakes	6	Resetting the Smart View Display	39
Steering Linkage	8	Speed Control Panel	40
Steering Column	10	Miscellaneous Electrical	42
Steering Gear	12	Lighting	44
Front Suspension	14	Lestronic® Charger (page 1)	46
Transmission Gear Case	16	Lestronic® Charger (page 2)	48
Rear Axle	18	Signet® Charger	50
Transmission Differential Case	18	Batteries	52
Rear Brakes	20	Seat Cushions and Deck, B 2-48 and B 2-54	54
Brake linkage	22	Seat Cushions BT 2-48	56
Rear Suspension	24	Seat Cushions BT 2-80	56
Motor	26	Decals	58
Electric Brake and Rear Motor Mount	28	Cab Options	60
Master Cylinder	30	Door Options, Steel Cab	62
Brake Lines		Door Options, Fiberglass Cab	64
with dual master cylinder	32	Hydraulic Dump Body Option	66
Brake Lines		Rear Cargo Box	68
with single master cylinder	34	Hitches	70

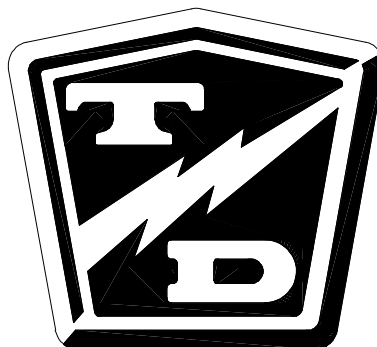



Front Axle

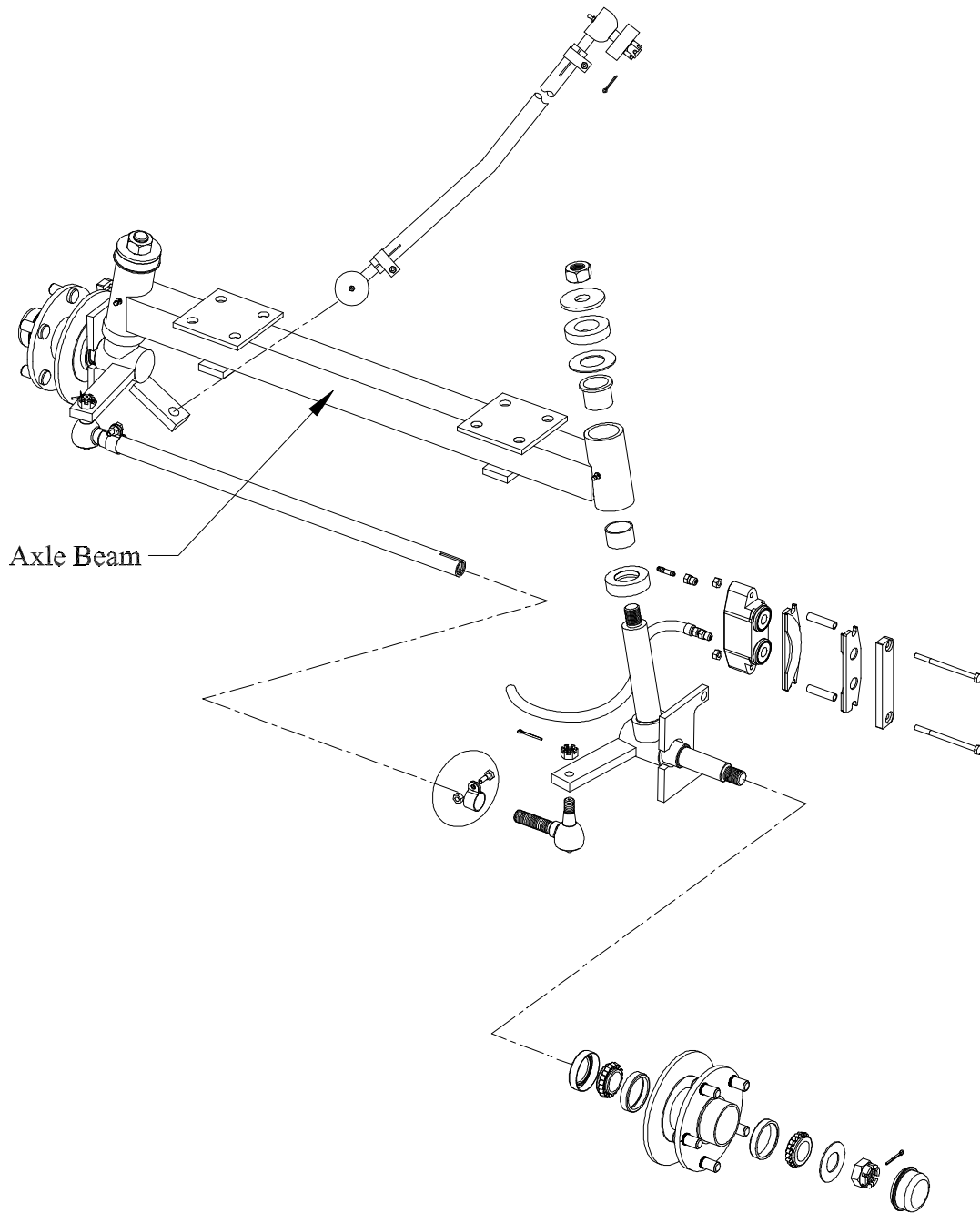

Front Axle			
ITEM #	PART #	DESCRIPTION	QTY
-	15-049-71	Axle Beam, B 2-48, BT 2-48, B 2-54	1
-	15-049-77	Axle beam, BT 2-80	1

See following pages for component breakdowns



Steering Knuckle

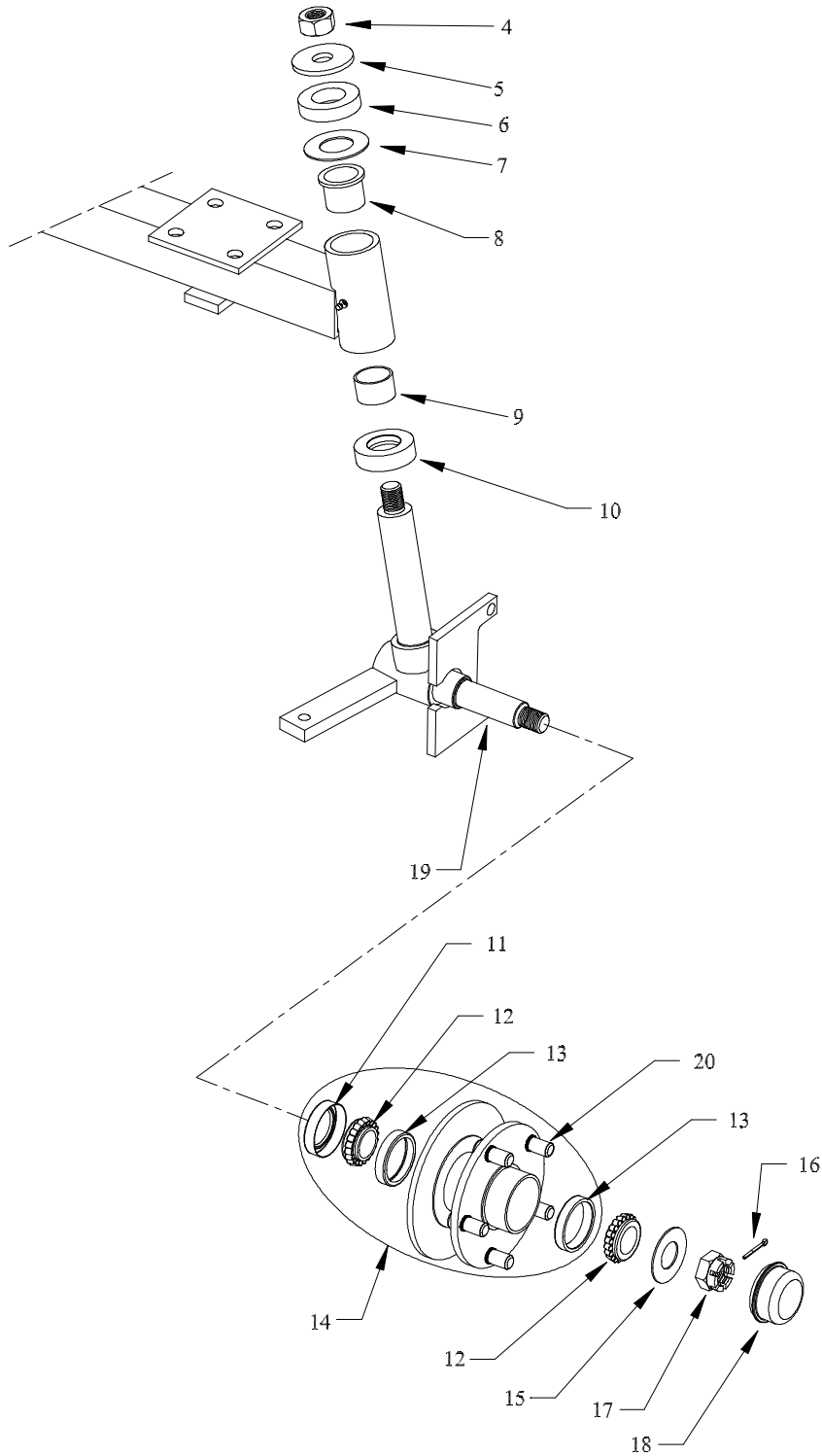

Steering Knuckle			
ITEM #	PART #	DESCRIPTION	QTY
-			
-			
-			
4	88-239-86	3/4-NF Hex Slotted Nut	2
5	88-228-60	3/4 Cut Flat Washer	2
6	98-603-07	Rubber Bushing	2
7	01-220-99	Washer	2
8	32-240-44	Bushing	2
9	32-240-43	Bushing	2
10	80-309-12	Thrust Bearing	2
11	45-338-00	Grease Seal	2
12	80-017-00	Tapered Bearing	4
13	80-103-00	Tapered Bearing Race	4
14	12-158-10	Wheel Hub W/Rotor (incl 1-#12, 1-#11, 1-#13)	2
	12-124-00	Wheel Hub no rotor (incl 1-#12, 1-#11, 1-#13)	2
15	88-228-61	3/4 SAE Flat Washer	2
16	88-527-14	1/8 x 1-1/2 Cotter Pin	2
17	88-239-85	3/4-NF Hex Slotted Nut	2
18	92-104-01	Bearing cap	2
19	21-020-20	Right Steering knuckle, disc brake	1
	21-020-21	Left Steering Knuckle, disc brake	1
	21-020-22	Right Steering knuckle, no brake	1
	21-020-23	Left Steering Knuckle, no brake	1
20	96-329-00	Wheel stud	10



Front Brakes

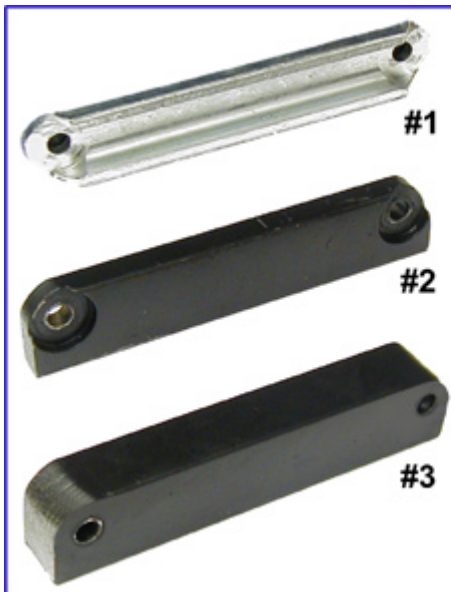
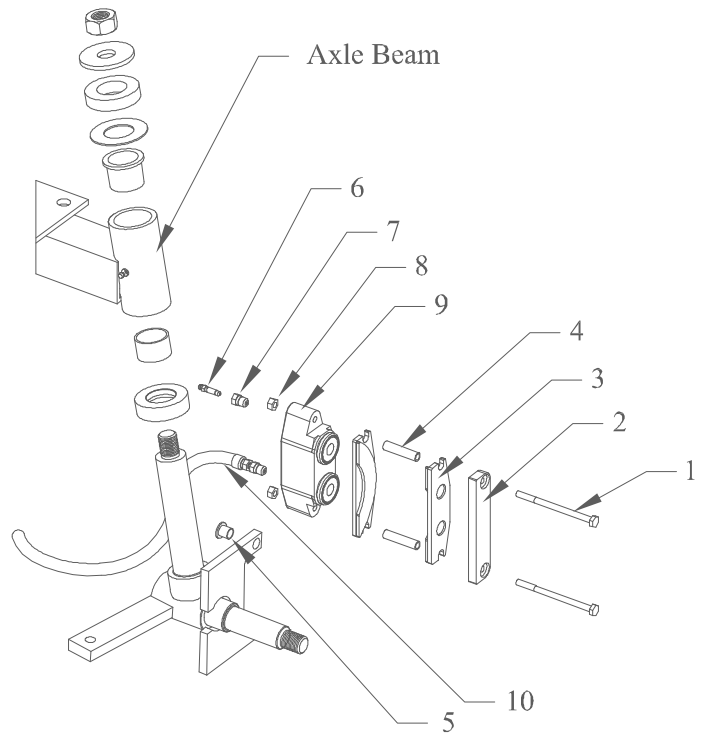

- #1) Formed steel secondary plate, part # not available.
- #2) Machined bar secondary plate, part # 41-350-51.
- #3) Heavy duty secondary plate, part # 41-350-91.

Your vehicle will have one of the three secondary plates shown to the left. It is not recommended to mix brake components on an axle. Both the left and right side brake should have identical components, including the secondary plate.

The #3 heavy duty plate cannot be used on the F2 or F3 rear axle. If replacing the #1 or #2 plate with the #3 plate then use 88-067-29 "1/4 x 4-1/4 Hex bolt, grade 8." Due to the increased size of the #3 plate, there may be interference with non-OEM wheels. Verify clearance to the wheel after installing the #3 plate.

All vehicles covered in this manual were equipped with brake assembly #1 from March, 2001 to March, 2006. Usage of brake assembly #2 started March 2006.

To identify a brake assembly, look for a stamped casting # along the side of the bleeder tower (see illustration #2). A casting # in this location is the #2 brake assembly. If there is no casting # in this location then it is the #1 assembly.

Due to that the brake, as an assembly, is interchangeable and may have been replaced in the field after it was delivered, it is possible that a vehicle may be equipped with brake assembly #1 or assembly #2 regardless of manufacturing date.

NOTE: DO NOT mix brake parts. The left and right side brake assemblies should be identical.

Front Brake			
ITEM #	PART #	DESCRIPTION	QTY
1	88-067-21	1/4 x 3-3/4 Hex bolt, grade 8, for standard secondary plate only	4
	88-067-29	1/4 x 4-1/4 Hex bolt, grade 8, for heavy duty secondary plate only	
2	See box on previous page	Plate, Secondary, Hydraulic Disc	2
3	41-348-70	Pad, Disc Brake	4
4	41-348-52	Spacer, Disc Brake	4
5	32-240-40	Bushing	4
6	99-588-00	Bleeder valve	2
7	99-588-01	Bleeder screw adapter	2
8	88-069-82	Locknut, 1/4" NC, Grade C	4
9	41-350-30	Brake Body Assembly, brake assembly #1 only	2
	41-351-30	Brake Body Assembly, includes 1, 2, 3, 4, 6, 7, 8, , brake assembly #2 only	2
10	See Brake Lines	Brake hose	
11	See Steering Knuckle	Front hub and rotor	

Brake Body Components			
ITEM #	PART #	DESCRIPTION	QTY
1	-	-	-
2	-	-	-
3	41-350-45**	Brake body, brake assembly #1 only	1
4	80-713-00**	O-ring, brake assembly #1 only	4
5	41-350-09	Boot	4
6	41-350-10	Piston	4

*** - A replacement Brake Body or O-ring is only available for brake assembly #1 (see above). If the these components must be replaced on a brake assembly #2, then the entire brake assembly must be replaced.*



Steering Linkage

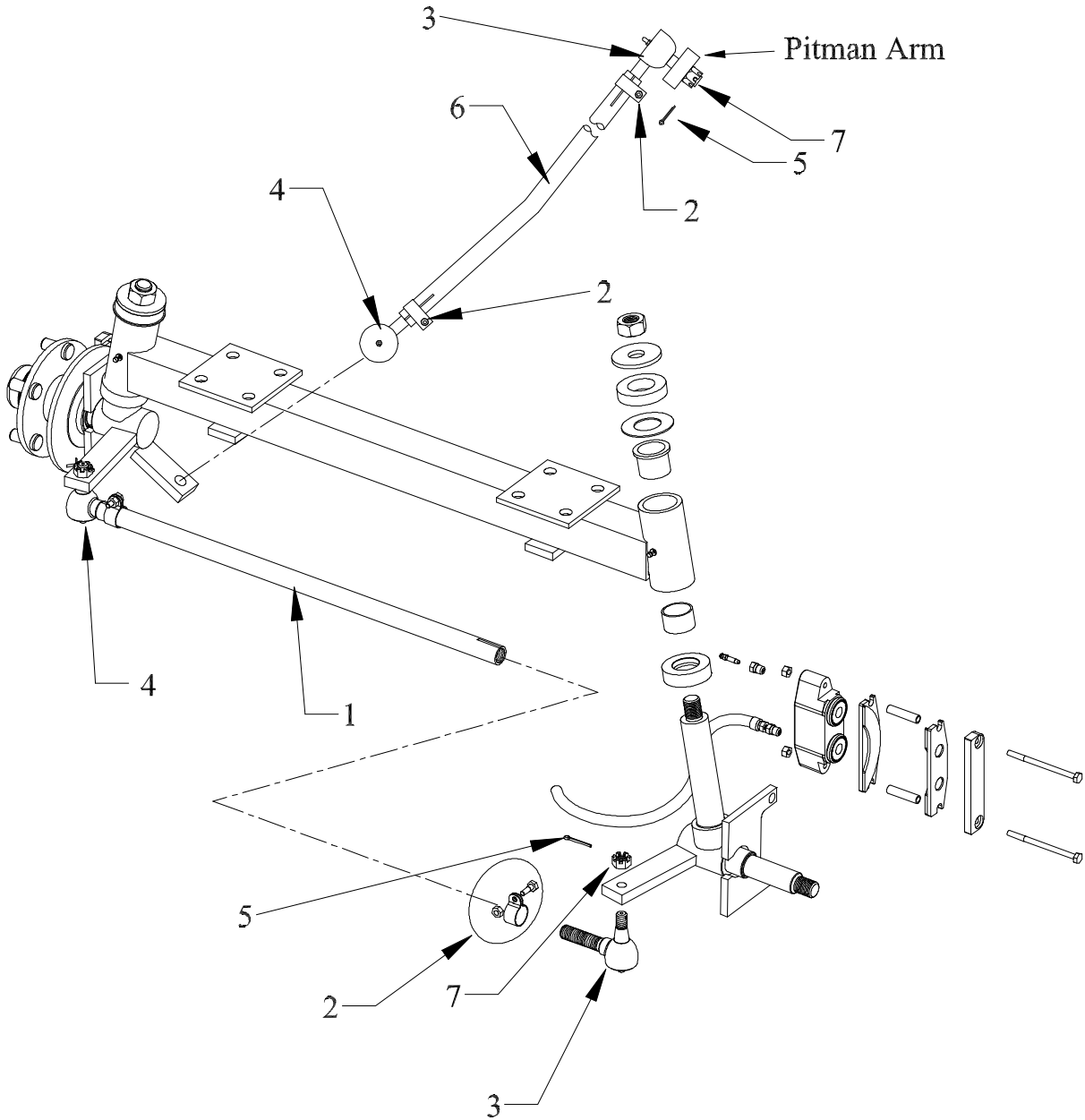

Steering Linkage			
ITEM #	PART #	DESCRIPTION	QTY
1	18-041-05	Tie rod, B 2-48, B 2-54, BT 2-48	1
	18-057-00	Tie rod, BT 2-80	1
2	86-510-00	Ball joing clamp	4
3	86-501-98	Ball joing (left)	2
4	86-501-99	Ball joint (right)	2
5	88-527-11	1/8 x 1 Cotter pin	4
6	18-057-11	Drag link	1
7	88-159-85	1/2NF Castle nut	4



Steering Column

The steering column is an integral part of the frame and is not shown. Part ID# 5 is located in the top of the steering column tube.

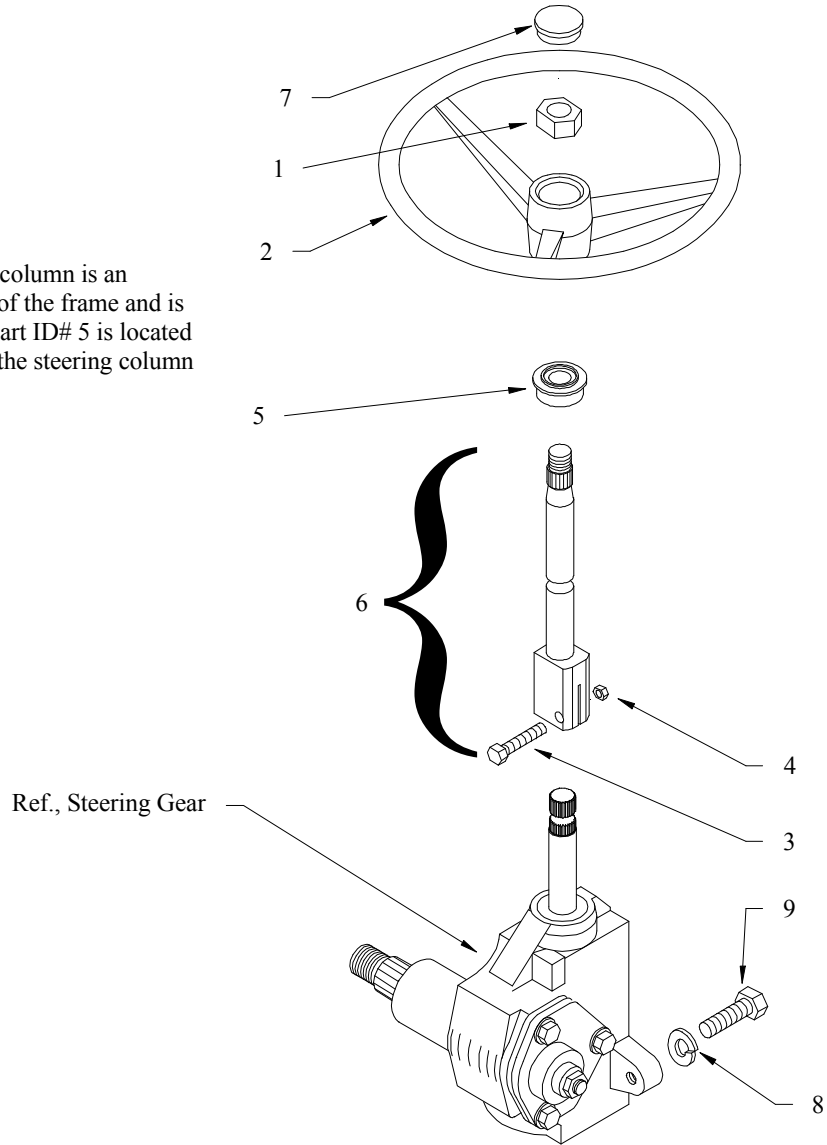

Steering Column			
ITEM #	PART #	DESCRIPTION	QTY
1	88-199-82	5/8NF Hex nut	1
2	19-011-20	Steering wheel	1
3	88-081-14	5/16NF x 1-1/2 Hex bolt, grade 8	1
4	88-089-84	5/16NF Hex lock nut, grade C	1
5	32-248-10	Upper bushing	1
6	20-031-65	Steering shaft assembly (incl. 3 and 4)	1
7	19-011-25	Steering wheel cap	1
8	88-128-62	7/16 Split lock washer	3
9	88-120-15	7/16 x 1 Hex bolt	3
Not Shown	88-279-82	7/8NF Thin pattern hex nut, Pitman shaft	1
	88-268-62	7/8 Split lock washer, pitman shaft	1



Steering Gear

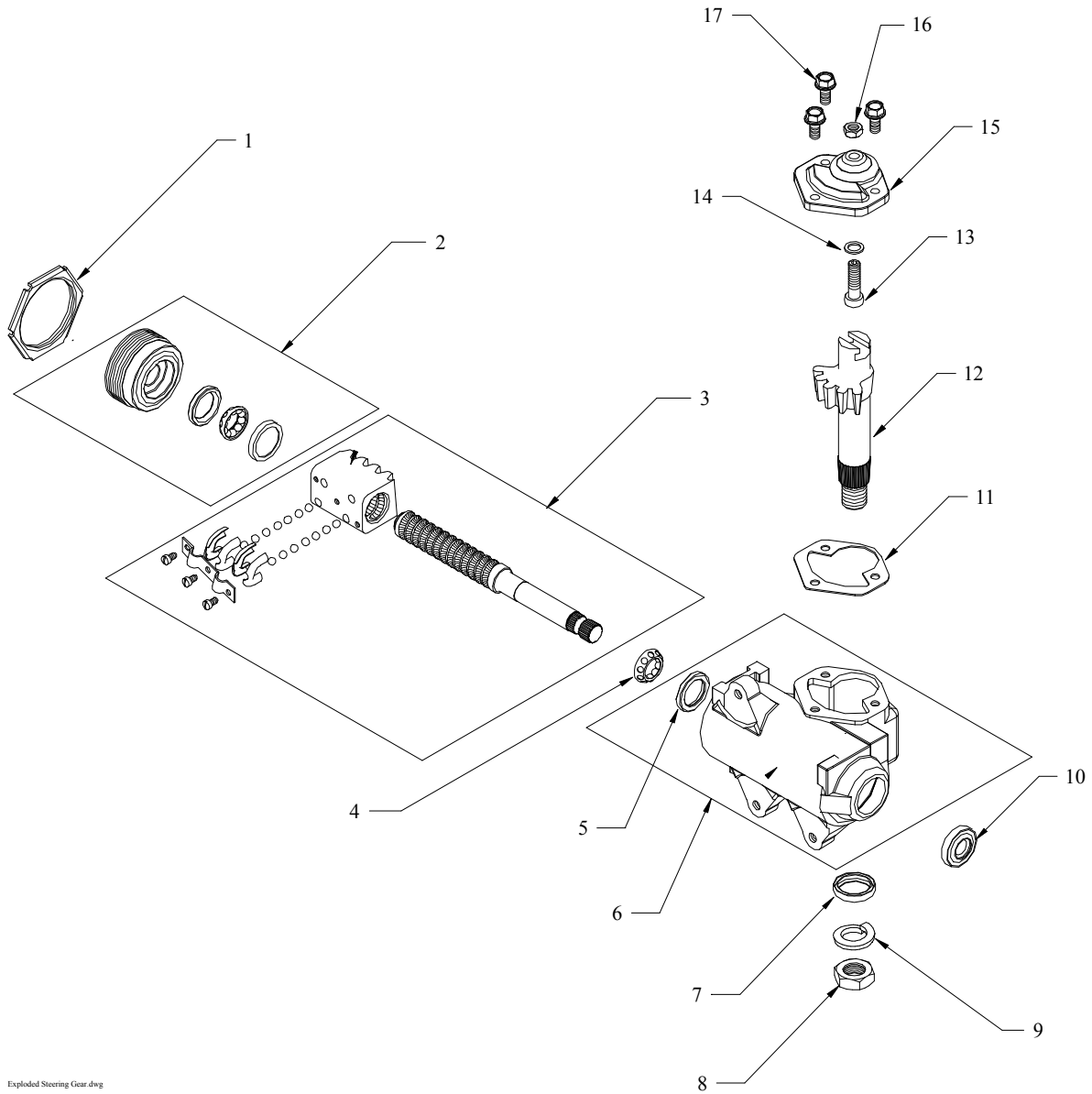

Exploded Steering Gear.dwg

Steering Gear 18-308-21			
ITEM #	PART #	DESCRIPTION	QTY
1	18-308-70	Locknut	1
2	18-308-71	Adjuster assembly	1
3	18-308-72	Worm assenbly	1
4	18-308-23	Upper worm bearing	1
5	18-308-22	Upper worm bearing race	1
6	18-308-77	Housing	1
7	18-308-78	Seal, pitman shaft	1
8	18-308-80	Nut, pitman shaft	1
9	18-308-81	Lock washer	1
10	18-308-79	Seal, input shaft	1
11	18-308-82	Gasket	1
12	18-308-76	Pitman shaft	1
13	18-308-75	Gear lash adjuster	1
14	18-308-85	Shim kit	1
15	18-308-84	Side cover	1
16	18-308-86	Jam nut	1
17	18-308-83	Bolt, side cover	3



Front Suspension

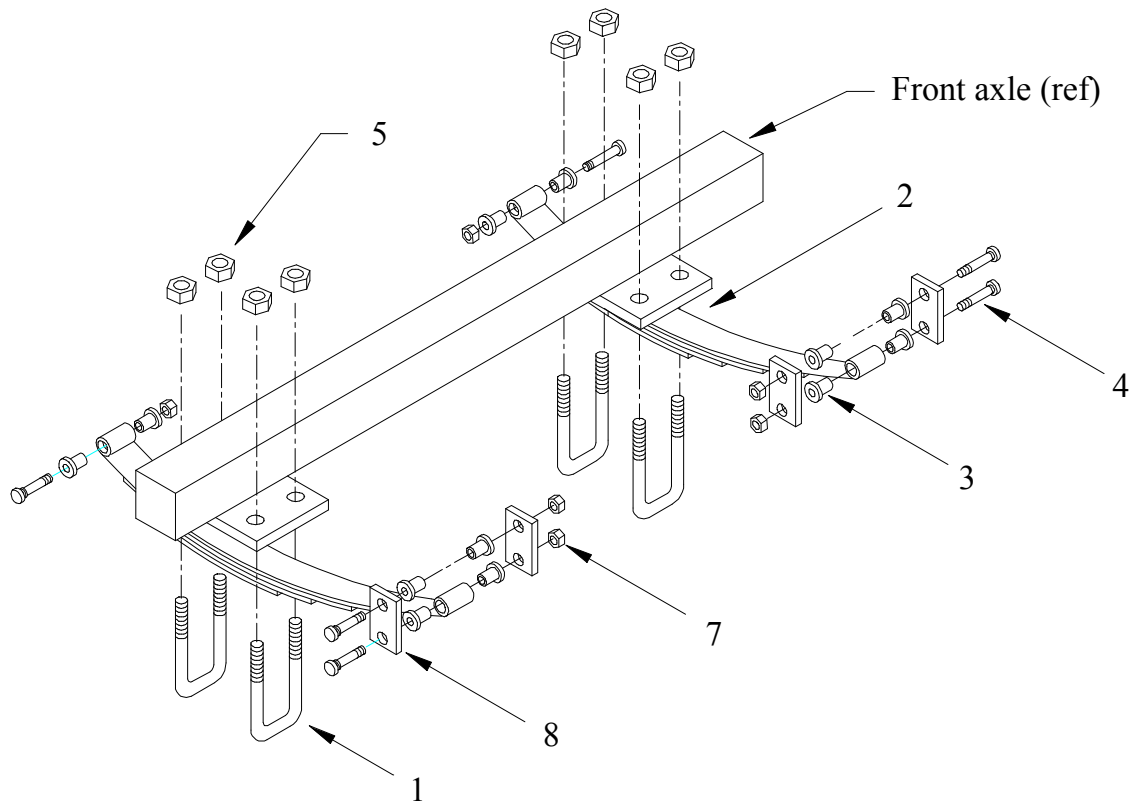

Front Suspension			
ITEM #	PART #	DESCRIPTION	QTY
1	96-121-00	U-bolt	4
2	85-498-00	Leaf spring, B 2-48, BT 2-48, BT 2--80	2
	85-486-00	Leaf spring, B 2-54	2
3	32-214-50	Bushing	12
4	96-240-00	1/2NC x 4 Hex bolt	6
5	88-149-81	1/2NC Lock nut	8
6	-	-	-
7	88-149-81	1/2NC Lock nut	6
8	16-872-00	Spring hanger	4



Transmission Gear Case

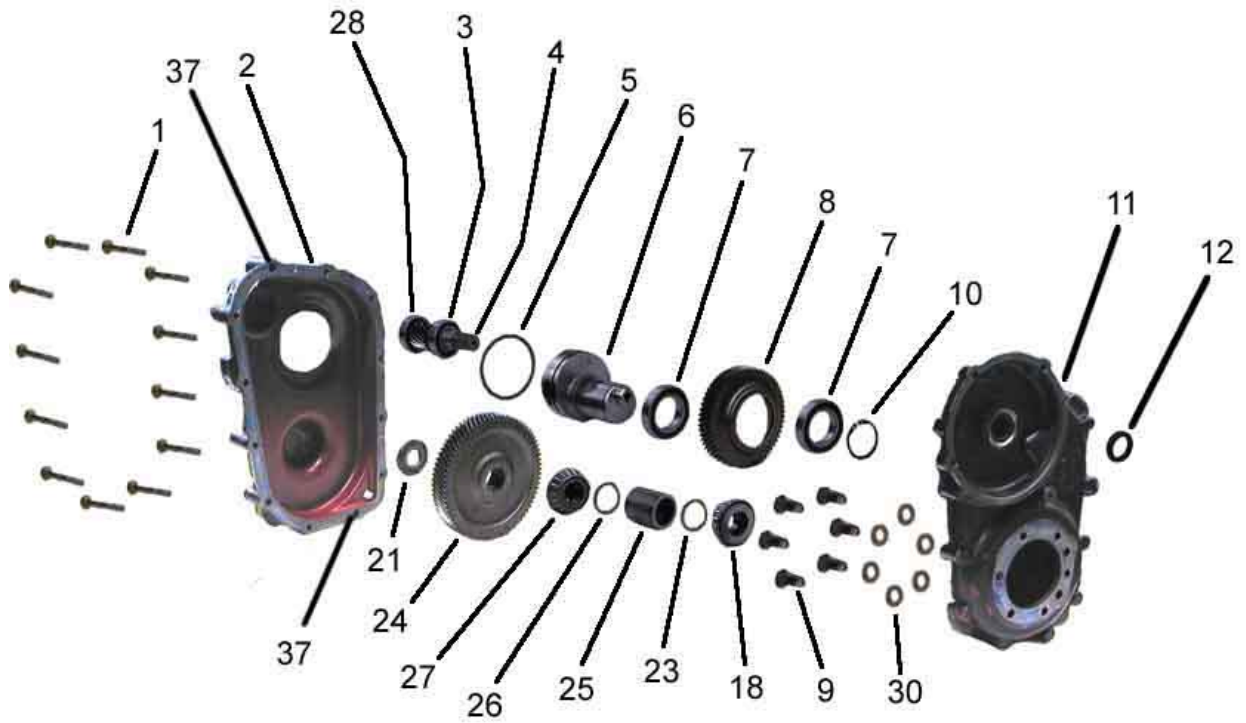

Transmission Gear Case			
ITEM #	PART #	DESCRIPTION	QTY
1	GT-71682	M8 x 60 bolt	12
2	GT-3287563	Gear case cover	1
3	GT-71259	Bearing	1
4	GT-3287513	Input shaft, 30:1	0 or 1
	GT-3287523	Input shaft, 24:1	0 or 1
	GT-3287533	Input shaft, 18:1	0 or 1
	GT-3287543	Input shaft, 12:1	0 or 1
5	GT-71982	O-ring	1
6	GT-3287503	Eccentric shaft	1
7	GT-72005	Bearing	2
8	GT-3287493	Idler gear	1
9	GT-70302	M10 x 30 Bolt	6
10	GT-71715	Snap ring	1
11	GT-3287553	Gear case housing	1
12	GT-72019	Seal	1
18	GT-71979	Bearing	1
21	GT-3273633	Pinion nut	1
23	See Note 1, previous page	Spacer	1
24	GT-3287453	Output gear, 30:1	0 or 1
	GT-3287463	Output gear, 24:1	0 or 1
	GT-3287473	Output gear, 18:1	0 or 1
	GT-3287483	Output gear, 12:1	0 or 1
25	GT-328	Spacer, 46.100mm	1
	GT-328	Spacer, 46.100mm	0 or 1
	GT-328	Spacer, 46.125mm	0 or 1
	GT-328	Spacer, 46.150mm	0 or 1
	GT-328	Spacer, 46.175mm	0 or 1
26	GT-3287903	Shim, 0.100mm	0 or 1
	GT-3287883	Shim, 0.400mm	0 or 1
	GT-3287893	Shim, 0.500mm	0 or 1
	GT-3287853	Shim, 0.600mm	0 or 1
	GT-3287863	Shim, 0.700mm	0 or 1
	GT-3287873	Shim, 0.800mm	0 or 1
27	GT-71068	Bearing	1
28	GT-72022	Bearing	1
30	GT-70299	10mm Washer	6
37	GT-3252633	Dowel pin	2



Rear Axle

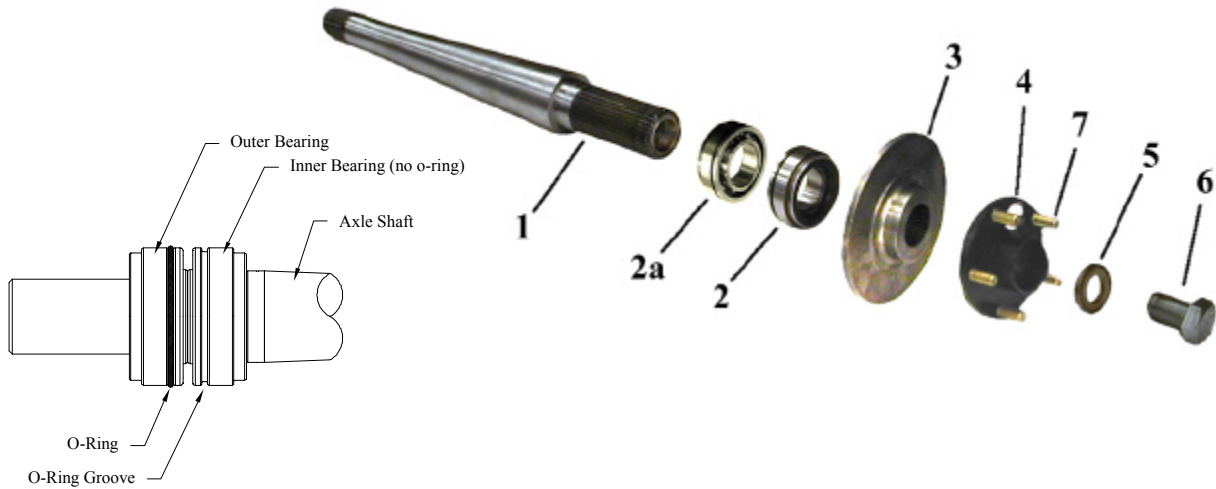

Inner bearing on optional double bearing axle does not have an oil seal or o-ring. Orientation of bearing should have o-ring groove adjacent to o-ring on outer bearing.

Transmission Differential Case

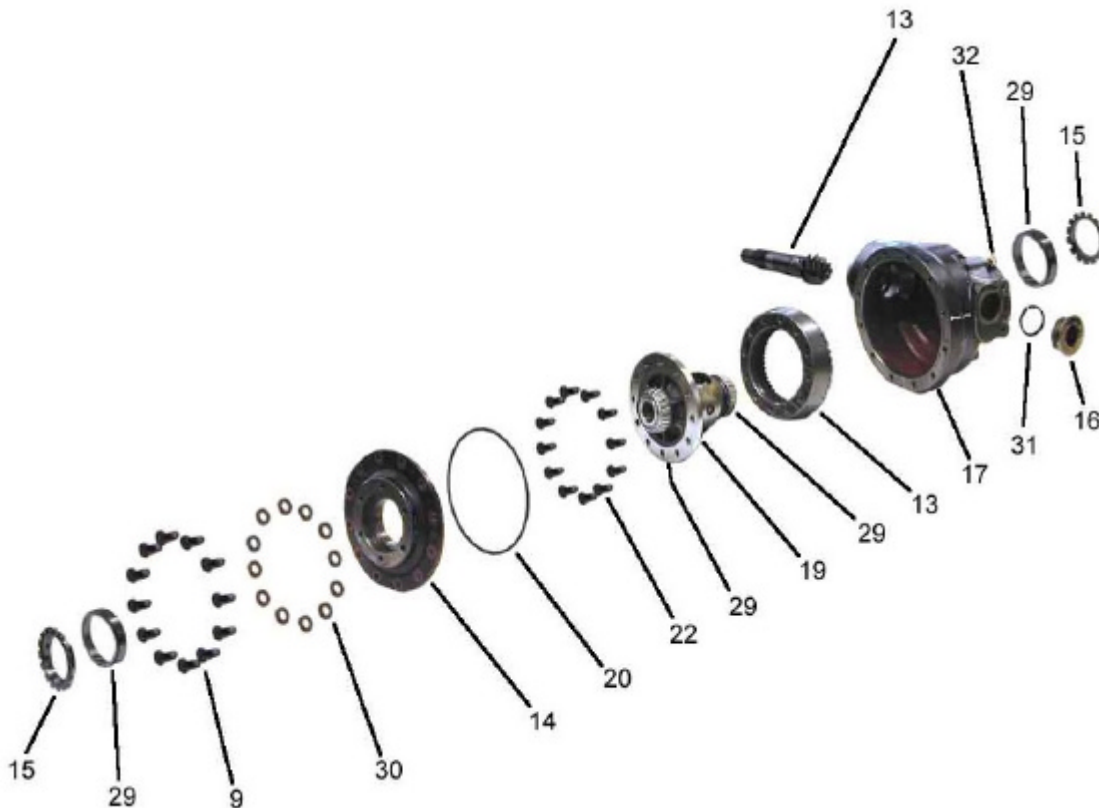

Rear Axle			
ITEM #	PART #	DESCRIPTION	QTY
1	41-154-10	Axle shaft, BT 2-80	2
	41-154-20	Axle shaft, B 2-48, BT 2-48, B 2-54 (single bearing)	2
	41-154-25*	*Axle shaft, B 2-54	2
2	80-505-20	Bearing	2
2a	80-505-30*	*Bearing	2*
3	41-490-11	Disc brake rotor	2
4	41-172-21	Hub	2
5	88-268-63	Flat washer	2
6	88-268-30	7/8-14 x 1.5 Bolt, grade 5	2
7	96-329-10	Wheel stud	10
Not shown	92-104-10	Hub cover	2
	41-290-40	Axle housing (L), B 2-48, BT 2-48, B 2-54 (single bearing)	1
	41-290-43	Axle housing (R), B 2-48, BT 2-48, B 2-54 (single bearing)	1
	41-290-46	Axle housing (L), BT 2-80	1
	41-290-47	Axle housing (R), BT 2-80	1
	41-290-78*	*Axle housing (L), B 2-54	1
	41-290-79*	*Axle housing (R), B 2-54	1
	89-113-30	M12 x 1.75 x 30mm Hex bolt (axle housing to center section)	6
89-113-60	M12 Split lock washer (axle housing to center section)	6	

* - B 2-54 optional double bearing axle after serial number 163766

Transmission Differential Case			
ITEM #	PART #	DESCRIPTION	QTY
9	GT-70302	M10 x 30 Bolt	12
13	GT-3287183	Ring and pinion gear set	1
14	GT-3297193	Differential case cover	1
15	GT-3287133	Adjusting ring	2
16	GT-70417	Fill/Level plug	1
17	GT-3287113	Differential housing	1
19	GT-3287143	Differential case	1
20	GT-72013	O-ring	1
22	GT-71896	M10 x 25 Bolt	12
29	GT-71978	Bearing and race	2
30	GT-70299	10mm Washer	12
31	GT-71881	Seal	1
32	GT-70052	Vent	1



Rear Brakes

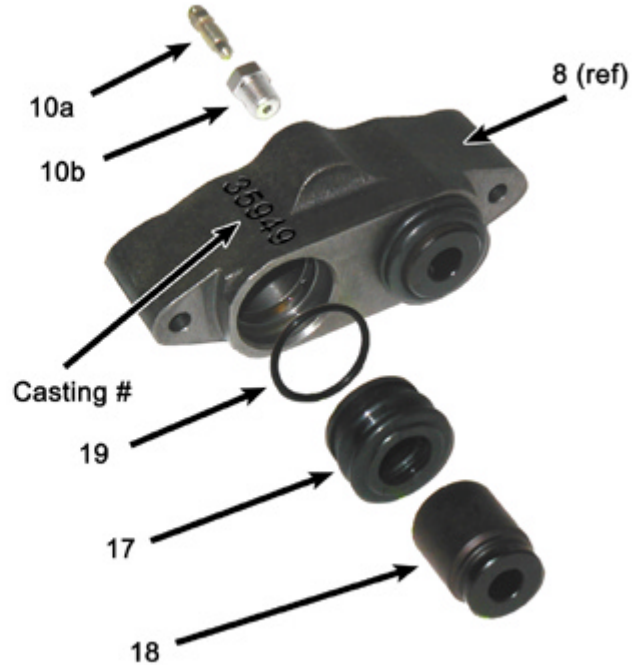
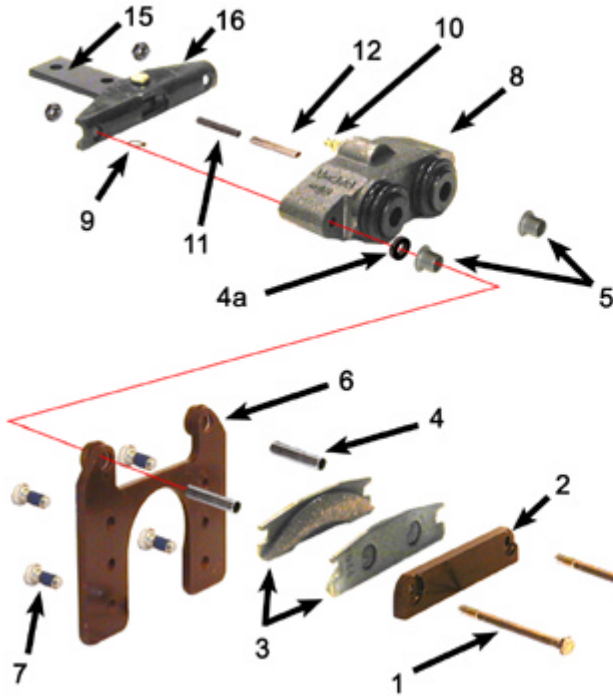

- #1) Formed steel secondary plate, part # not available.
- #2) Machined bar secondary plate, part # 41-350-51.
- #3) Heavy duty secondary plate, part # 41-350-91.

Your vehicle will have one of the three secondary plates shown to the left. It is not recommended to mix brake components on an axle. Both the left and right side brake should have identical components, including the secondary plate.

The #3 heavy duty plate cannot be used on the F2 or F3 rear axle. If replacing the #1 or #2 plate with the #3 plate then use 88-067-29 "1/4 x 4-1/4 Hex bolt, grade 8." Due to the increased size of the #3 plate, there may be interference with non-OEM wheels. Verify clearance to the wheel after installing the #3 plate.

3/1/2008: Part numbers 41-350-72 (bracket) and 41-350-73 (plastic trim) were added to support the parking brake arm on the rear calipers. The bracket is mounted under the arm, retained by one of the drive mounting u-bolts. Refer to bulletin BUL-08-01-001* for details. The addition of the bracket helps reduce brake noises. This is a temporary revision and will be in use until the brake body is updated to provide additional support (see note below).

*-A copy of the bulletin is included on the CD provided with the vehicle. If you do not have the CD, a copy of the bulletin may be obtained through your dealer or by contacting Taylor-Dunn.

For vehicles manufactured after 6/24/2008, refer to supplement M7-001-40 for information regarding Front and Rear brake caliper assemblies and components. The supplement is included on the vehicle documentation CD delivered with the vehicle.

All vehicles covered in this manual were equipped with brake assembly #1 from March, 2001 to March, 2006.

Usage of brake assembly #2 started March 2006.

To identify a brake assembly, look for a stamped casting # along the side of the bleeder tower (see illustration). A casting # in this location is the #2 brake assembly. If there is no casting # in this location then it is the #1 assembly.

Due to that the brake, as an assembly, is interchangeable and may have been replaced in the field after it was delivered, it is possible that a vehicle may be equipped with brake assembly #1 or assembly #2 regardless of manufacturing date.

NOTE: DO NOT mix brake parts. The left and right side brake assemblies should be identical.

Rear Brakes			
ITEM #	PART #	DESCRIPTION	QTY
1	88-067-21	1/4 x 3-3/4 Hex bolt, grade 8, for standard secondary plate only	4
	88-067-29	1/4 x 4-1/4 Hex bolt, grade 8, for heavy duty secondary plate only	4
	88-069-82	1/4NC locknut, grade C	4
2	See box on previous page	Secondary plate	2
3	41-348-70	Brake pad	4
4	41-348-57	Spacer	4
4a	32-204-30	Washer, spacer, brake assembly #2 only (see above)	4
5	32-240-41	Bushing, brake assembly #1 only (see above)	4
	32-204-30	Bushing, brake assembly #2 only (see above)	4
6	41-350-28**	Mounting bracket, includes #5, brake assembly #1 only (see above)	2
7	96-327-10	Hex bolt with thread locking compound	8
8	41-350-68**	Brake body assembly, brake assembly #1 only (see above)	2
9	88-840-11	Retaining ring	2
	41-350-52	Clevis pin	2
10a	99-588-00	Brake bleeder	2
10b	99-588-01	Adapter, brake bleeder	2
11	41-350-56	Park brake pin	2
12	32-220-03	Bushing, brake assembly #1 only (see above)	1
	*	Bushing, brake assembly #2 only (see above)	2
15	41-350-53	Brake arm	2
16	41-350-12	Park brake lever bracket	2
17	41-350-09	Boot	4
18	41-350-10	Piston	4
19	80-713-00**	O-ring, brake assembly #1 only (see above)	4
Not shown	41-350-59	Extension, brake arm	2
	41-351-78	Brake assembly #2, left side, complete	
	41-351-79	Brake assembly #2, right side, complete	

**** - A replacement Brake Body, O-ring, or Mounting Bracket is only available for brake assembly #1 (see above). If these components must be replaced on a brake assembly #2, then the entire brake assembly must be replaced.**



Brake linkage

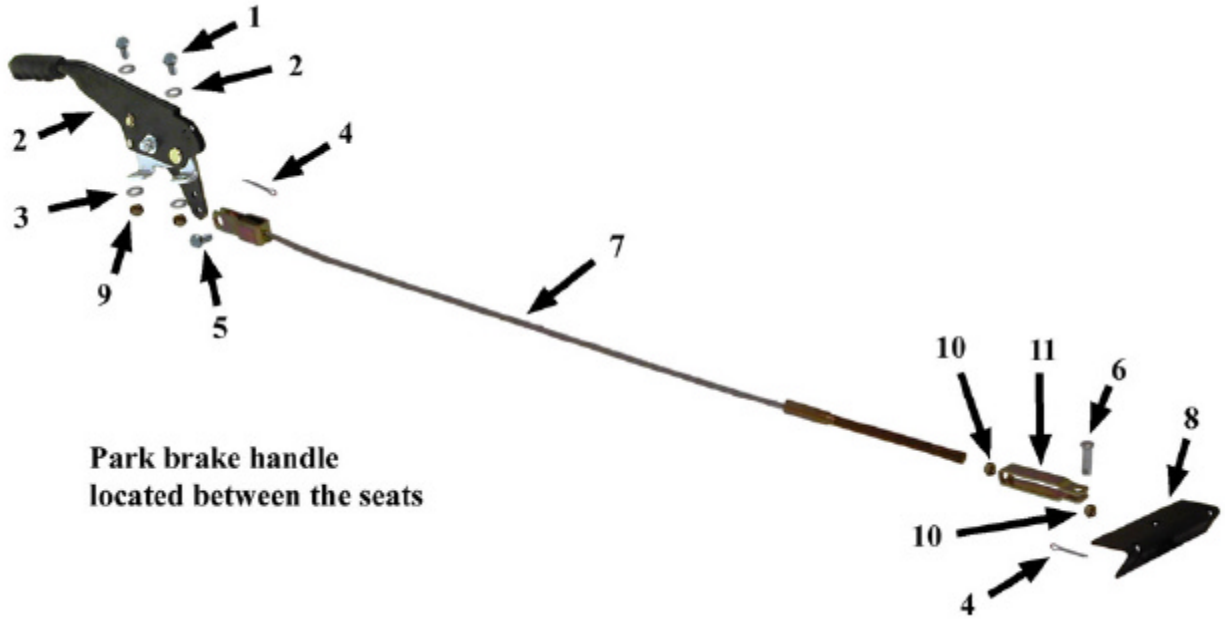

BRAKE LINKAGE			
ITEM #	PART #	DESCRIPTION	QTY
1	88-080-11	Bolt, 5/16 x 1", Hex Head	2
2	51-344-80	Park Brake Handle	1
3	88-088-61	Washer, 5/16"	4
4	88-089-81	Locknut, 5/16"	2
5	96-813-00	Adjusting Brake Cable Assembly, B 2-48, BT 2-48, B 2-54	1
	96-820-20	Adjusting Brake Cable Assembly, BT 2-80	1
6	96-771-00	Clevis Pin, 3/8 x 3/4"	1
7	01-204-32	Brake Equalizer	1
8	96-760-00	Brake Cable Clevis	1
9	88-099-80	Nut, 5/16" Hex Head	2
10	96-773-00	Clevis Pin, 5/16 x 1"	1
11	88-527-11	Cotter Pin, 1/8 X 1" Steel	2
Not Shown	41-350-59	Brake arm extension (located at the rear brakes), starting serial number 157201	2
	96-826-12	Park Brake Cable from equalizer to the rear brakes	2
	85-250-00	Brake pedal return spring	1
	50-009-00	Master cylinder push rod (99-510-02 or 99-511-00 master cylinder)	1
	50-009-05	Master cylinder push rod (99-511-20 master cylinder)	1
	96-762-00	Clevis (pushrod)	1

Rear Suspension

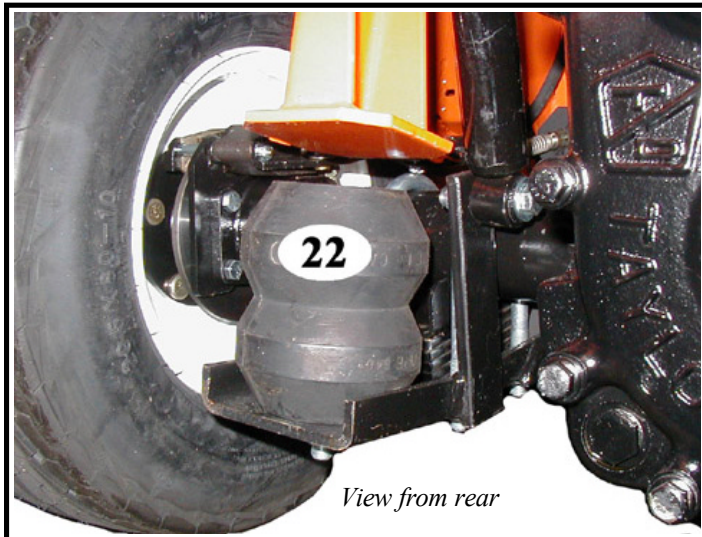
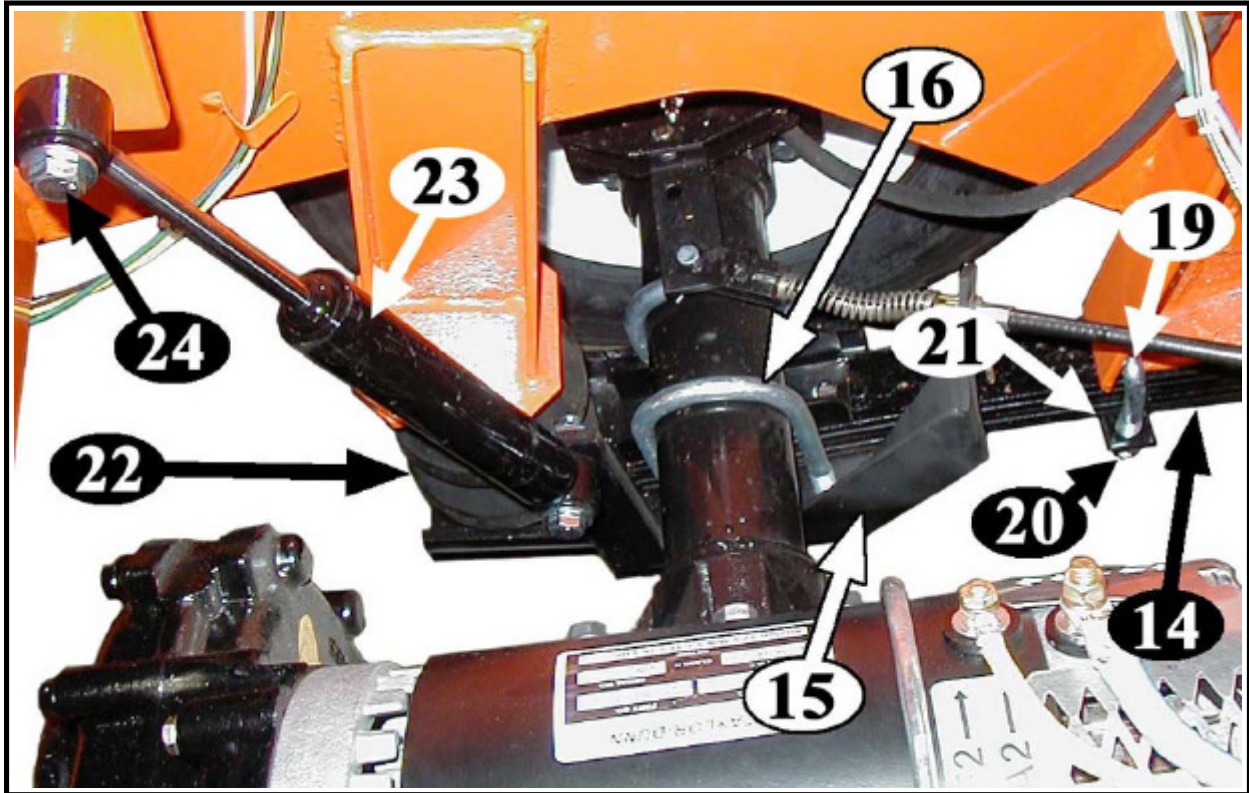

Rear Suspension			
ITEM #	PART #	DESCRIPTION	QTY
Not shown	96-240-00	1/2NC x 4 Spring bolt (front of the leaf spring)	2
	32-214-50	Spring bushing (front of the leaf spring)	4
14	85-510-17	Leaf spring	2
15	16-861-44	Spring mounting plate (left)	1
	16-861-45	Spring mounting plate (right)	1
16	96-114-00	U-bolt	4
	88-159-84	1/2NC Nylon lock nut	8
18	-	-	-
19	96-103-00	U-bolt	2
20	88-149-81	1/2NC Lock nut	4
21	50-460-00	Strap	2
22	98-002-00	Rubber overload spring	2
23	86-602-00	Shock	2
24	88-120-17	7/16NC x 2-1/4 Hex bolt	2
	88-129-81	7/16NC Lock nut	2
	88-128-60	7/16 Flat washer	2



Motor

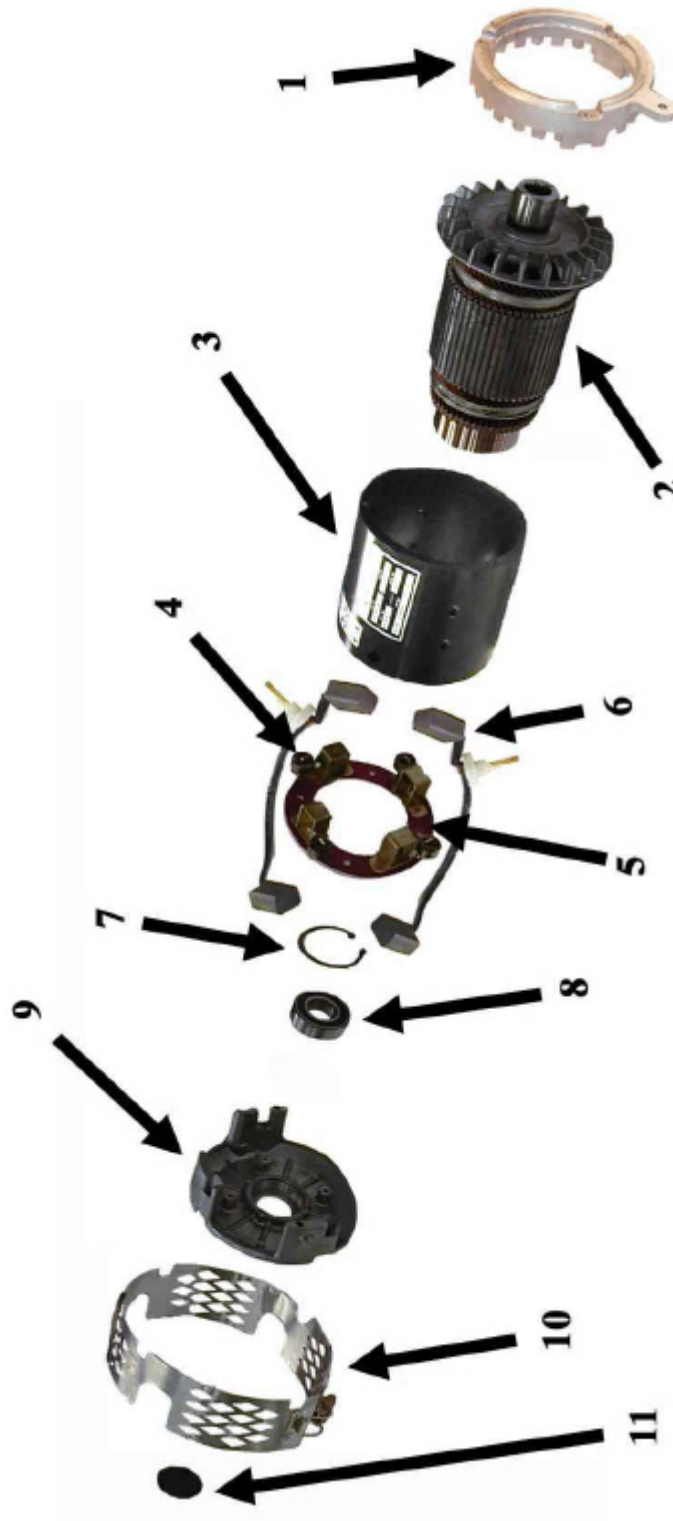

Motors, Separately Excited Field						
Motor Spec # Motor Part #						
ITEM #	DESCRIPTION	DV1-4002 70-054-40	XPI789 or DY24001 70-054-41	DV1-4003 70-057-40	XP-1786 or DD3-4004 70-052-40	203-21-4001 or XPI820A 70-072-41
1	Front housing	70-421-10	70-421-10	70-421-10	*	*
2	Armature	70-400-00	70-400-00	70-400-10	*	*
3	Field assembly	70-209-30	*	70-209-40	*	*
4	Brush spring	70-412-20	70-412-20	85-403-00	70-412-20	85-403-00
5	Brush holder	70-170-00	70-170-00	70-173-00	70-170-00	70-173-00
6	Brush	70-109-00 (2)	70-109-00 (2)	70-170-10 (8)	70-109-00 (2)	70-170-10 (1)
7	Bearing retainer	70-417-00	70-417-00	70-417-00	70-417-00	*
8	Bearing	80-212-00	80-212-00	80-212-00	80-212-00	*
9	Rear housing	70-421-20	70-421-20	70-421-30	70-421-20	*
10	Brush cover	70-421-00	70-421-00	70-421-40	70-421-00	*
11	Dust cap	98-930-00	95-930-00	95-930-00	95-930-00	-
Not shown	1-1/8" lg. grade 8 mounting bolt	88-067-17	88-067-17	88-067-17	88-067-17	-
*	2" lg. Grade 8 mounting bolt	88-067-22	88-067-22	88-067-22	88-067-22	-
		Not available at time of printing				
Note 1:	The original motor provided under part number 70-054-40 has been discontinued. It has been replaced by 70-054-41. The 70-054-41 motor has slightly more power & torque. The 70-054-40 motor can be directly replaced with the 70-054-41 motor. The 70-054-41 motor will perform with the original parameters in the Sevcon® controller; however the vehicle will have about a 15% reduction in top speed. To take full advantage of the increased performance of the 70-054-41 motor, new parameters must be programmed into the Sevcon® controller. Please contact Taylor-Dunn® Manufacturing for details on returning the controller for re-programming.					



Electric Brake and Rear Motor Mount

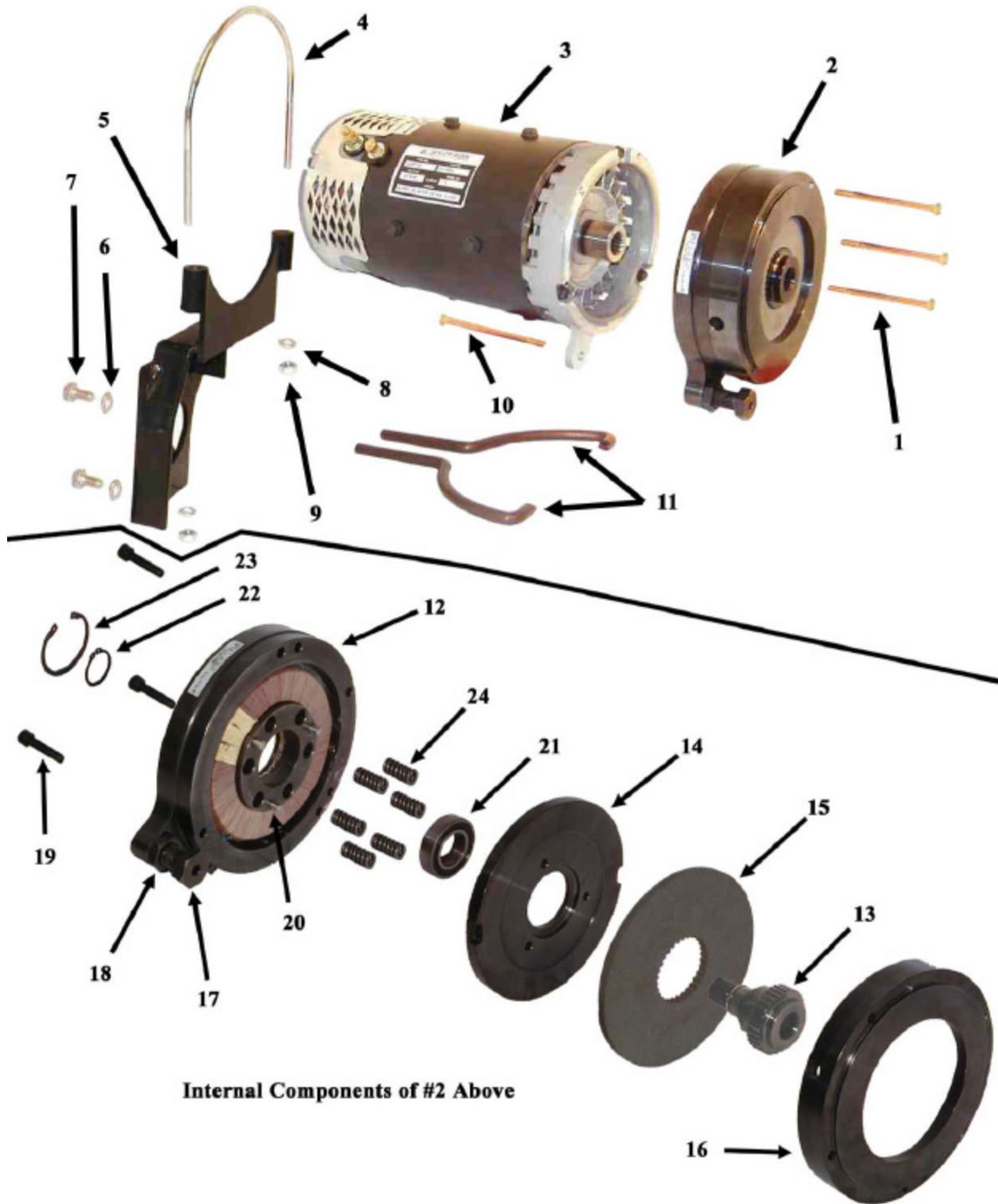

<i>ELECTRIC BRAKE AND REAR MOTOR MOUNT</i>			
<i>ITEM #</i>	<i>PART #</i>	<i>DESCRIPTION</i>	<i>QTY</i>
1	88-067-22	Bolt, 1/4 X 2" NC, Grade (no brake option)	3
	88-067-29	Bolt, 1/4 X 4-1/4" NC, Grade 8 (brake option only)	3
2	41-355-00	Automatic Electric Brake Unit	1
3	See Motor	Motor (Typical)	1
4	96-114-10	U-Bolt, 5/16" NF, Motor Support	1
5	K66-600-03	Motor, Support Bracket	1
6	88-128-62	Lockwasher, 7/16"	2
7	89-111-27	Bolt, 10m X 1.5 X 20 Hex Head	2
8	88-088-62	Lockwasher, 5/16"	2
9	88-099-80	Nut, 5/16" NF	2
10	88-067-17	Bolt, 1/4 X 1-1/8" NC, Grade 8 (no brake option)	
	88-067-29	Bolt, 1/4 X 4-1/4" NC, Grade 8 (brake option only)	1
11	96-500-04	Tool, Electric Brake, Manual Release	2
12	*	Magnet and Coil Sub Assembly	1
13	*	Hub	1
14	*	Armature	1
15	*	Friction Plate	1
16	*	Mounting Plate	1
17	*	Hex Head Bolt Spacer	1
18	*	Locknut	1
19	*	Screw, Socket Head Cap	3
20	*	Dowel Pin	3
21	*	Ball Bearing, Deep Groove	1
22	*	External Circlip	1
23	*	Internal Circlip	1
24	*	Coil Compression Spring	6
Not Shown	*	Wiring Harness	1



Master Cylinder

Dual Reservoir

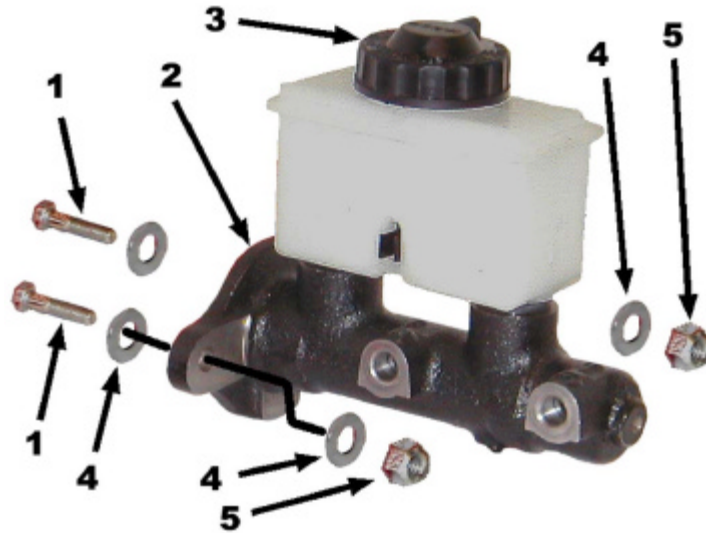

Single Reservoir

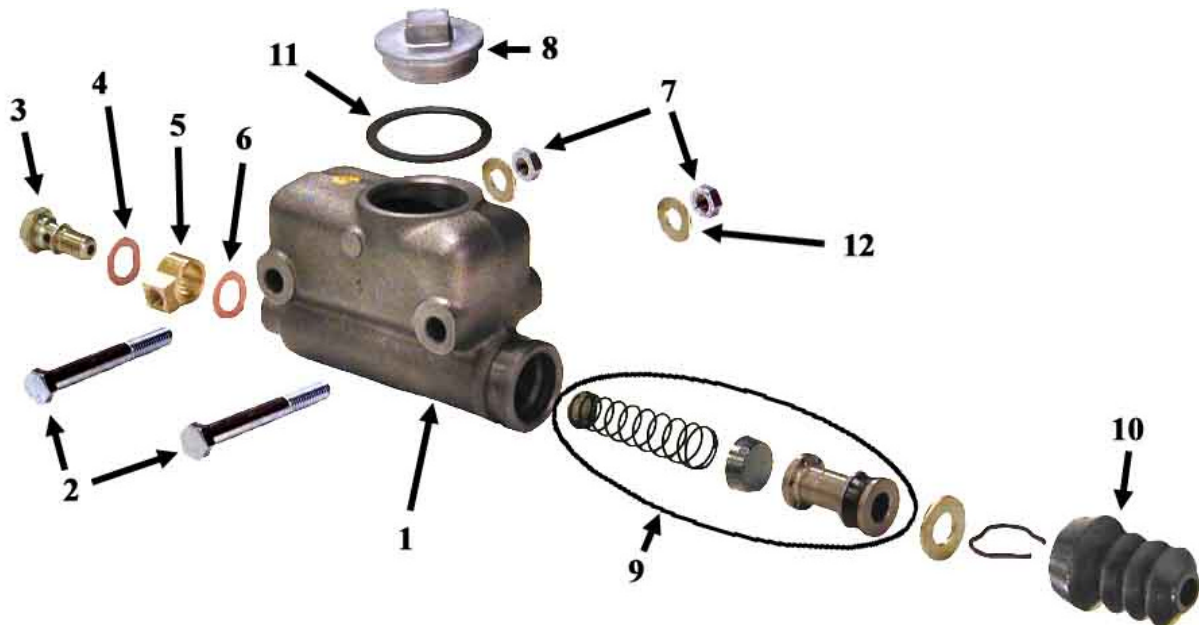

Dual Reservoir Master Cylinder			
<i>ITEM #</i>	<i>PART #</i>	<i>DESCRIPTION</i>	<i>QTY</i>
1	88-080-14	Bolt, 5/16" X 1-1/2" NC, Hex Head	2
2	See Usage Table	Master Cylinder (includes item #3)	1
3	99-511-52	Cap Seal, Master Cylinder	1
	99-511-53	Cap, Master Cylinder	1
4	88-088-61	Washer, 5/16"	4
5	88-089-81	Locknut, 5/16"	2
Not Shown	99-511-51	Rubber Boot, Master Cylinder	1

Single Reservoir Master Cylinder			
<i>ITEM #</i>	<i>PART #</i>	<i>DESCRIPTION</i>	<i>QTY</i>
1	99-511.00	Master cylinder assembly	1
2	88-101-20	Hex bolt	2
3	99-579-00	Fitting, bolt	1
4	99-572-00	Washer	1
5	99-566-00	Fitting	1
6	99-571-00	Washer	1
7	88-109-81	Hex lock nut	2
8	99-510-52	Cap	1
9	99-510-61	Rebuild kit for 1" bore	1
10	99-510-51	Boot	1
11	99-510-53	Gasket	1
12	88-108-60	flat washer	2

MASTER CYLINDER USAGE				
Brake Option	MODEL			
	B2-48 Manufactured before 1/9/2003	B2-48 Manufactured after 1/9/2003	B2-54 Up to Serial Number 149749	B2-54 After Serial Number 149749
	Rear Disc Only	99-510-02 ¹	99-511-00 ²	-
4-Wheel Disc	99-510-02	99-511-20	99-510-02	99-511-20

1 - On vehicles equipped with rear brakes only, 99-511-00 can be used in place of 99-510-02

2 - Do not use 99-511-00 on vehicles equipped with 4-wheel brakes.

Brake Lines with dual master cylinder

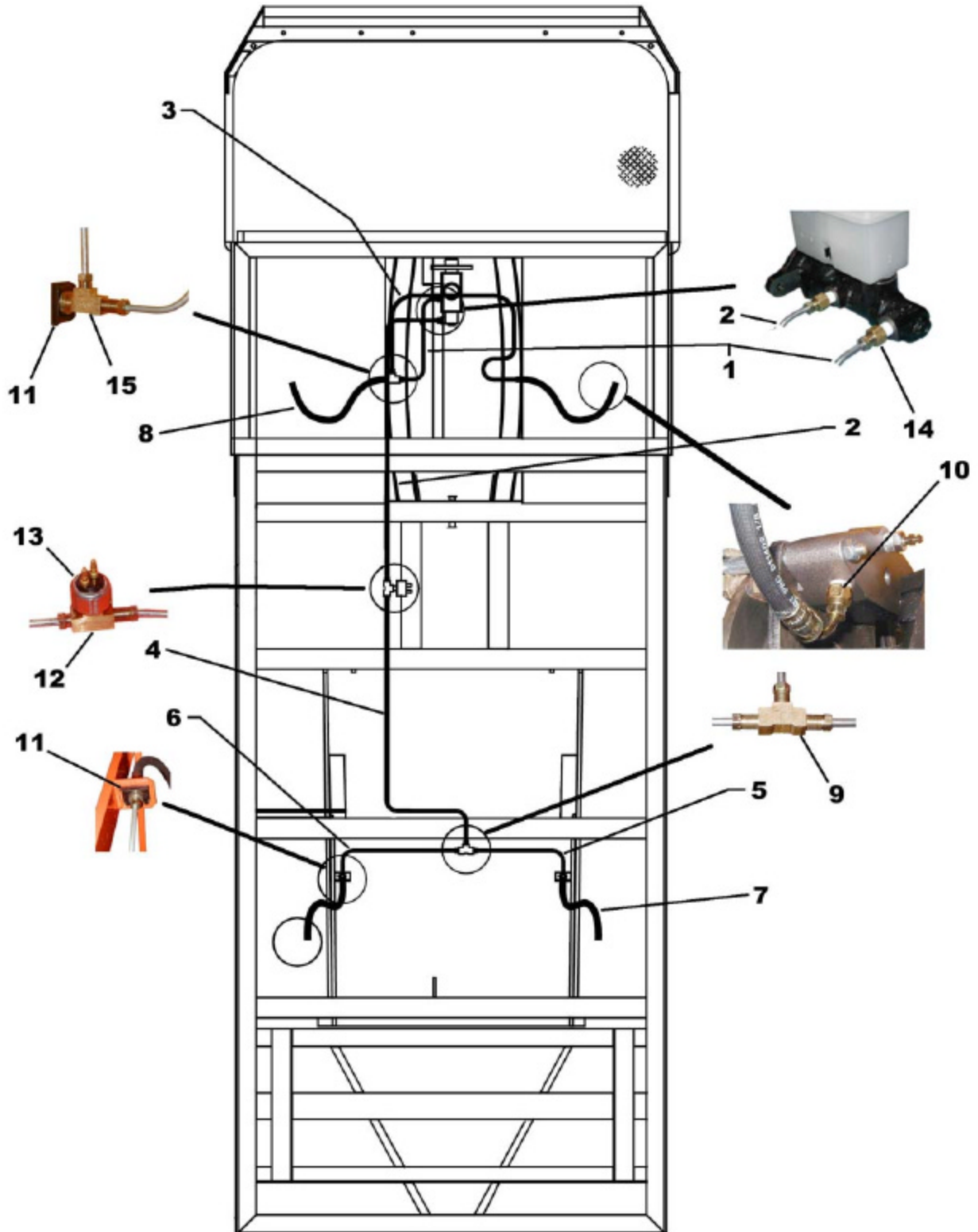

Brake Lines with Dual Reservoir Master Cylinder			
ITEM#	PART #	DESCRIPTION	QTY
1	99-609-61	Brake Line, Front	1
2	99-607-59	Brake Line, Rear	1
3	99-606-51	Brake Line, Front Right	1
4	99-607-62	Brake Line, Rear, B 2-48, B 2-54, BT 2-48	1
	99-608-58	Brake Line, Rear, BT 2-80	1
5	99-603-68	Brake Line, Rear Right, B 2-48, B 2-54, BT 2-48	1
	99-608-56	Brake Line, Rear Right, BT-280	1
6	99-603-68	Brake Line, Rear Left, B 2-48, B 2-54, BT 2-48	1
	99-608-57	Brake Line, Rear Left, BT 2-80	1
7	99-580-20	Brake Hose, Rear	2
8	99-580-10	Brake Hose, Front	2
9	99-564-00	T-Fitting	1
10	99-575-10	Adaptor, 3/16T X 1/8P	2
11	99-576-00	Hose Clip	4
12a	99-591-00	Brake light switch adaptor (optional)	0 or 1
13	71-110-00	Brake Light Switch (optional)	0 or 1
14	99-575-32	Adaptor, 3/16T x M10-1.0	2
15	99-559-00	T-Fitting, Single Male Flare to 2-Female Flare, 3/16 Tube	1



Brake Lines with single master cylinder

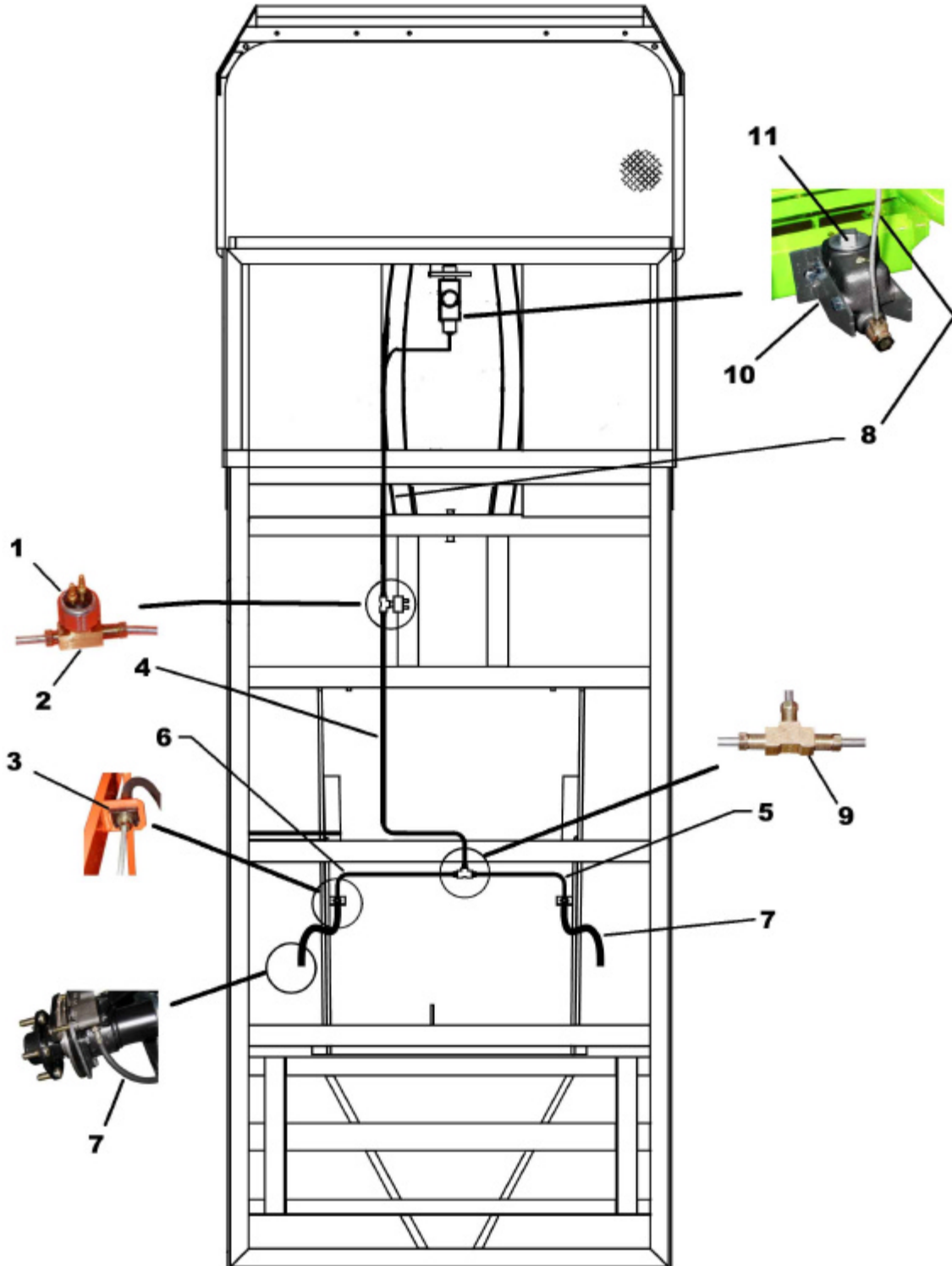

Brake Lines with Single Reservoir Master Cylinder			
ITEM#	PART #	DESCRIPTION	QTY
1	71-110-00	Brake Light Switch (optional)	1
2	99-591-00	Brake light switch adaptor (optional)	1
3	99-576-00	Hose Clip	2
4	99-608-58	Brake Line, Rear, BT 2-80	1
	99-607-62	Brake Line, Rear, B 2-48, B 2-54, BT 2-48	1
5	99-604-56	Brake Line, Rear Right, BT 2-80	1
	99-603-68	Brake Line, Rear Right, B 2-48, B 2-54, BT 2-48	1
6	99-604-57	Brake Line, Rear Left, BT 2-80	1
	99-603-68	Brake Line, Rear Left, B 2-48, B 2-54, BT 2-48	1
7	99-580-20	Brake Hose, Rear	2
8	99-607-61	Brake Line, Front	1
9	99-564-00	T-Fitting	1
10	01-204-86	Master Cylinder Mounting Bracket	1
11	See Master Cylinder Parts	Master Cylinder	4



Wheels and Tires

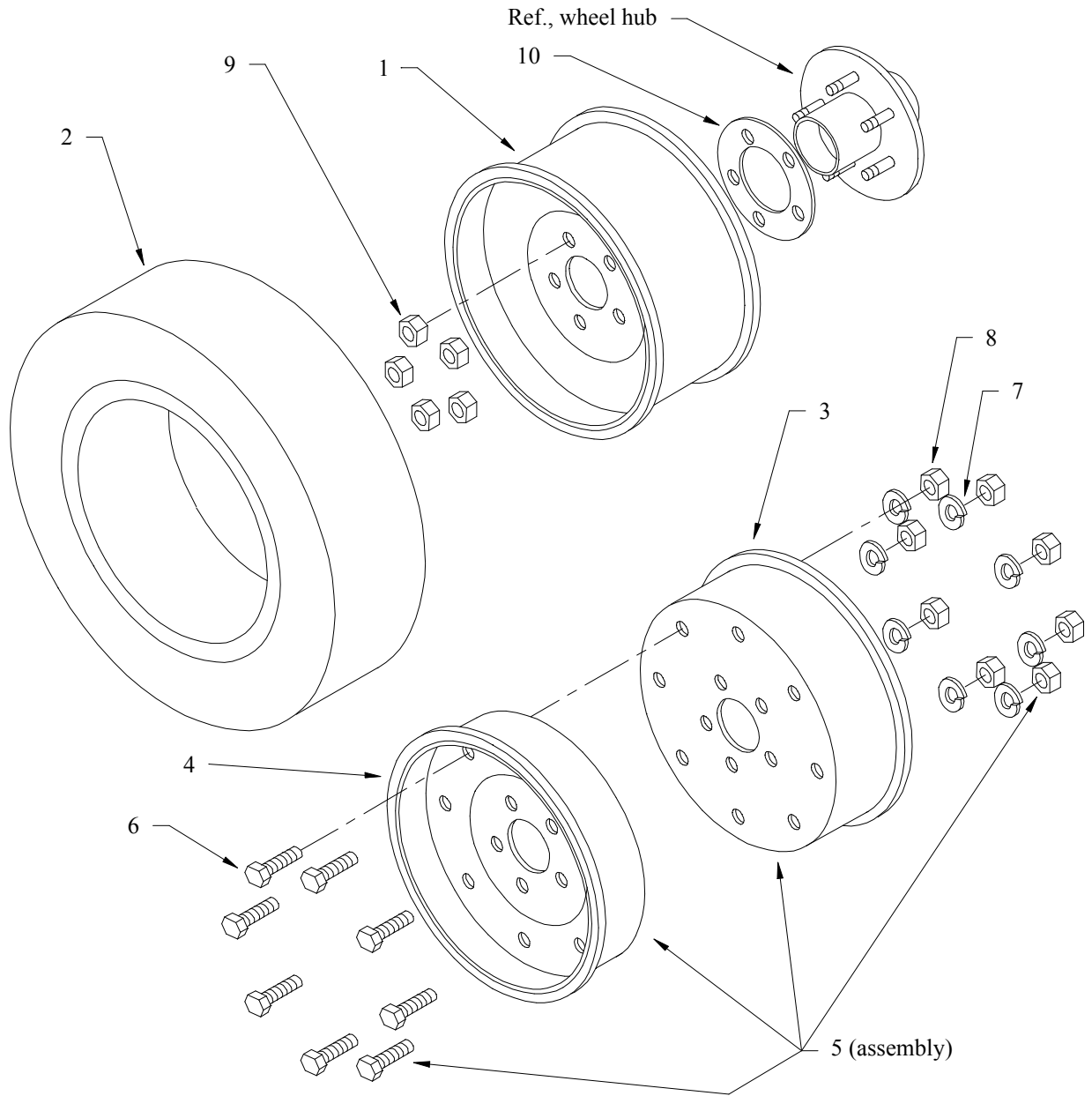

Wheels and Tires			
ITEM #	PART #	DESCRIPTION	
1	Wheels		
	12-012-00	5 x 8" Tubeless	
	12-020-00	8.5 x 8 Tubeless	
	12-050-00	12-1/8 Diameter Cast Iron	
2	Tires		
	10-075-00	4.80 x 8 LR B Pneumatic	
	10-076-00	4.80 x 8 LR C Pneumatic	
	10-081-00	5.70 x 8 LR B Pneumatic	
	10-082-00	5.70 x 8 Extra Grip	
	10-083-00	5.70 x 8 LR C	
	10-093-00	8.50 x 8 LR B	
	10-091-10	8.50 x 8 Knobby	
	10-092-00	8.50 x 8 LR C	
	10-086-00	5.00 x 8 Man-Toterswith lugs (soft solid)	
	10-264-00	20 x 8 x 10 LR E	
	10-250-00	16 x 4 x 12 Solid rubber	
	Split Rim Wheels		
	3	12-041-12	Inner Wheel (2.5 bead)
4	12-041-13	Outer Wheel (2.5 bead)	
5	12-041-00	Wheel Assembly, 2.5 bead width (includes #3, #4, #6, #7, #8)	
3a	12-042-12	Inner Wheel (12-bolt)	
4a	12-042-13	Outer Wheel (12-bolt)	
5a	12-042-00	Wheel Assembly, 3.75 bead width (includes #3a, #4a, #6, #7, #8)	
6	88-110-09	3/8 x 3/4-NF Hex Bolt, grade 5	
7	88-109-62	3/8 Split Lock Washer	
8	88-119-80	3/8-NF Hex Nut	
9	97-236-00	Wheel Nut	
Not Shown	13-989-00	Valve stem, tubless tire only	
Not Shown	11-041-00	8.50 x 8 Tube	
Not Shown	11-040-00	5.70 x 8 Tube	
	11-030-00	4.80 x 8 Tube	
Tire and Wheel Assemblies			
	13-734-00	4.80 x 8 LR B Pneumatic	
	13-734-11	4.80 x 8 LR B Split Rim Pneumatic	
	13-739-10	4.80 x 8 LR C Split Rim Pneumatic	
	13-952-10	16 x 4 x 12 Solid Rubber, Cast Iron Wheel	
	13-742-00	5.70 x 8 LR B Pneumatic	
	13-742-40	5.70 x 8 Man-Toter	
	13-742-11	5.70 x 8 Split Rim	
	13-746-10	8.50 x 8 Pneumatic	
	13-746-15	20 x 8 x 10 8-ply	



Instrument Panel (dash)

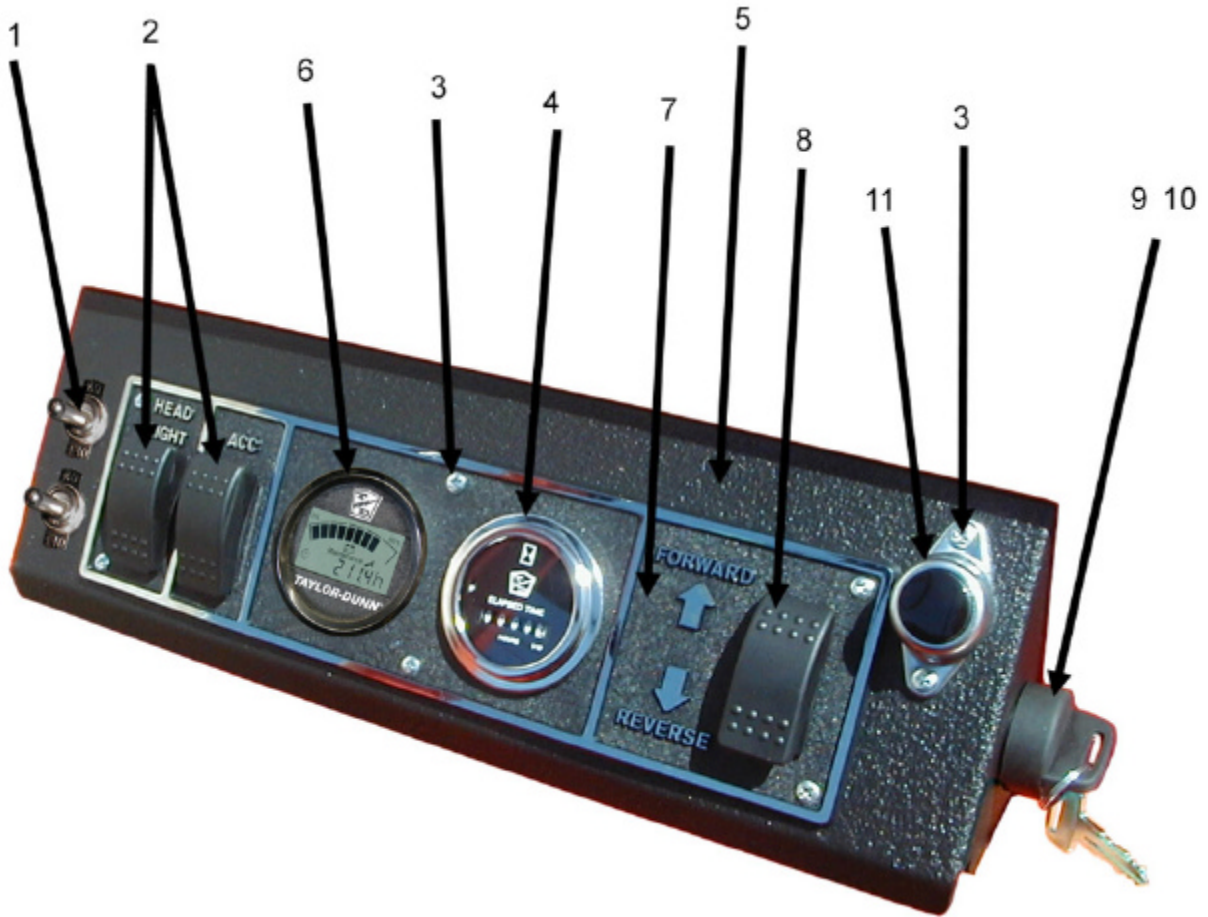

#6 Analog battery status indicator



#6 Bargraph battery status indicator

Instrument Panel			
ITEM #	PART #	DESCRIPTION	QTY
1	71-100-00	Aux. switch	Opt
2	71-039-11	SPST rocker switch	1 or 2
3	88-817-07	Sheet metal screw	8
4	74-000-00	Hour meter	0 or 1
5	01-200-09	Dash console, no cab	1
	00-610-01	Dash console, with cab	1
6	74-010-00	Smart view display (see information below)	1
	74-009-00	Analog battery status indicator, 36-volt	1
	74-009-02	Bargraph battery status indicator, 36-volt	
	74-009-48	Bargraph battery status indicator, 48-volt	
7	94-304-13	Dash	1
8	71-039-02	F&R switch	1
9	71-120-10	Key switch (incl #10)	1
10	71-120-90	Key	1
11	71-501-00	Horn switch	1
Not shown	01-204-19	Console cover	1

NOTE: If your vehicle was not originally equipped with the Smart View display, then the Sevcon speed control must be reprogrammed before the display will function.

If you have the Smart View display and wish to have the maintenance feature turned on, then the Sevcon speed control must be reprogrammed.

To reprogram the Sevcon speed control, the speed control must be returned to the factory. Contact your local Taylor-Dunn® distributor for more information.

The Smart View Display will only work with the Sevcon control system.

Resetting the Smart View Display

The meter should only be reset after the preventative maintenance has been performed. Taylor-Dunn® part number 62-027-40 Hand set (available with instructions as part number 62-027-61) must be used to reset the meter. Refer to the handset instructions (D0-100-08) for information on the procedure to reset the display.



Speed Control Panel

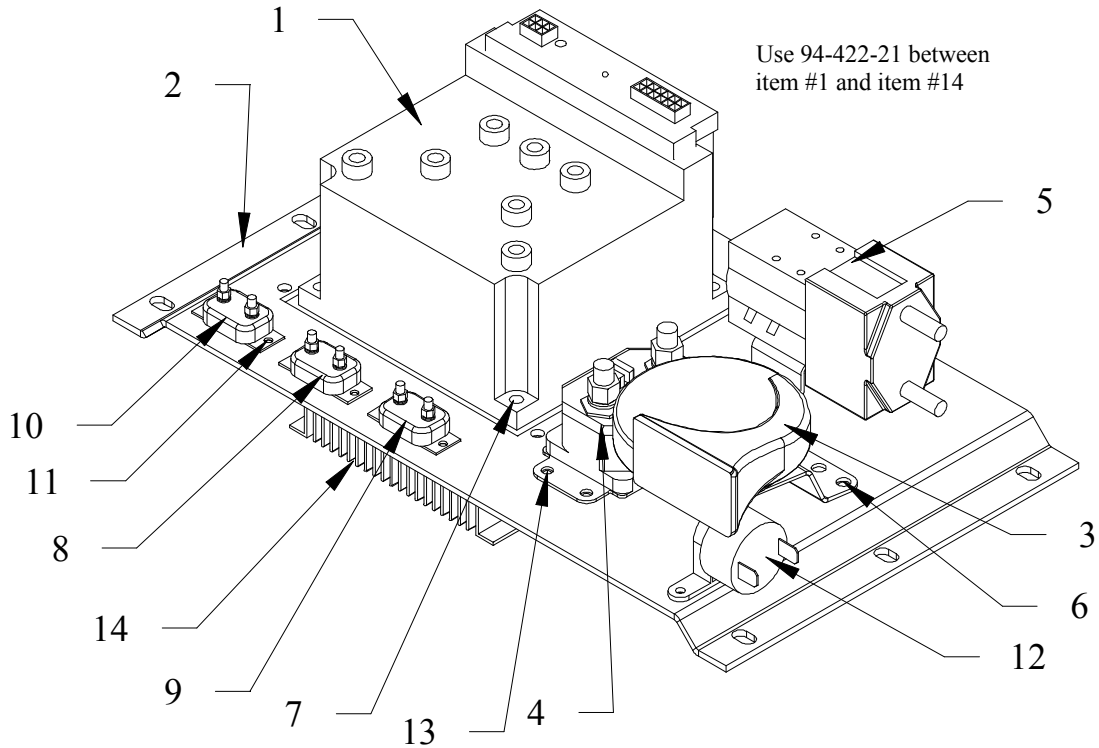

Refer to the serial number data plate on the controller base to determine which controller (400A or 500A) is on your vehicle.
 632S45617 = 400 Amp controller
 632S15622 = 500 Amp controller



** - Early models were equipped with the above solenoid. This solenoid is no longer available. If the solenoid is to be replaced, order items #5 "Line Contactor" and #5 "Mounting Bracket".

Speed Control Panel			
ITEM #	PART #	DESCRIPTION	QTY
1	62-400-05 (see note)	Speed controller, 400 Amp	1
	62-400-15 (see note)	Speed controller, 500 Amp	
2	01-200-06	Mounting panel	1
3	73-004-20	Horn	1
4	See Below	See below	1
5**	71-300-02	Line contactor	1
	71-300-01	Mounting bracket	1
6	88-838-06	#14 x 1/2 Sheet metal screw	4
7	88-060-13	1/4 NC x 1-1/4 Hex bolt	4
8	79-840-00	10 Amp circuit breaker	1
9	79-840-20	20 Amp circuit breaker	1
10	79-840-20	20 Amp circuit breaker	1
11	88-818-06	#8 x 1/2 Sheet metal screw	8
12	73-005-01	Reverse/Motion alarm	1
13	88-818-06	#8 x 1/2 Sheet metal screw	1
14	62-400-13	Heat sink	1
	88-838-06	#14 x 1/2 Sheet metal screw	4
Not shown	69-068-55	Resistor (across #5 power terminals)	1

NOTE: To order part number 62-400-05 or 62-400-15, you will need to provide the vehicle serial number. The controller will be programmed to match the vehicle as originally manufactured.

Item #4:

Depending on the model and serial number of the vehicle, item #4 will be a circuit breaker or a fuse.

Model #	Serial # range	Description	Part #
B0-248-36	146189 to current production	Circuit Breaker	79-844-20
B0-248-48	146189 to 173490, and 173625, 173671	Circuit Breaker	79-844-20
B0-248-48	173541 to current production, except 173625, 173671	Fuse	79-829-15
B0-254-36	146186 to current production	Circuit Breaker	79-844-20
BT-248-36	150719 to current production	Circuit Breaker	79-844-20
BT-248-48	150719 to 173425 and 173505 to 173508	Circuit Breaker	79-844-20
BT-248-48	173426 to current production except 173505 to 173508	Fuse	79-829-10
BT-280-36	159916 to 173621	Circuit Breaker	79-844-20
BT-280-36	173622 to current production	Fuse	79-829-10
BT-280-48	159916 to 172122	Circuit Breaker	79-844-20
BT-280-48	173551 to current production	Fuse	62-016-59



Miscellaneous Electrical

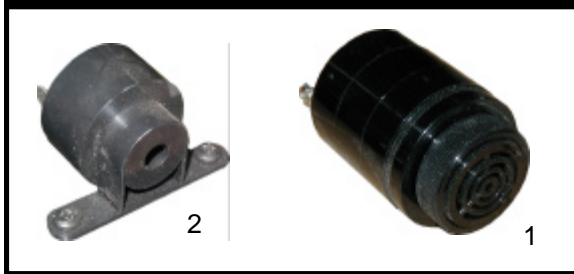

Motion Alarms

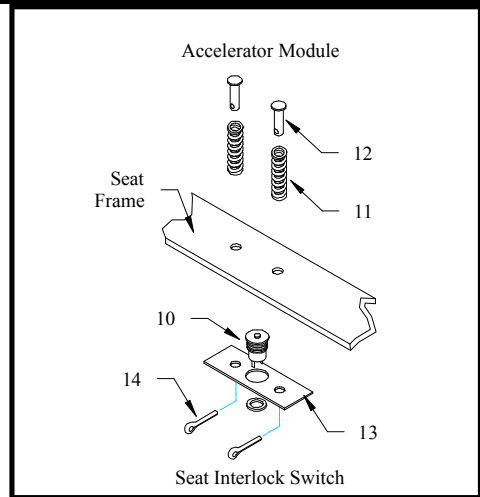

Miscellaneous Wire Harness Clamps

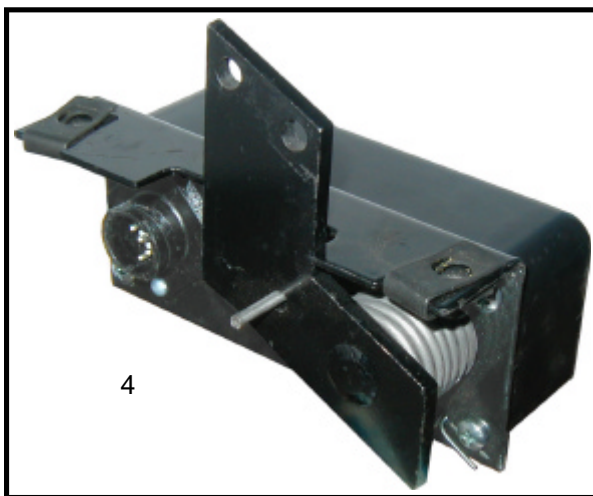

Miscellaneous Electrical			
ITEM #	PART #	DESCRIPTION	QTY
Not Shown	75-152-80	Chassie Control Harness, BT 2-80	1
	75-152-03	Chassie Control Harness, BT 2-48, B 2-48, B 2-54	1
	75-152-13	Control panel harness	1
	75-152-81	Power Harness, BT 2-80	1
	75-152-11	Power Harness, BT 2-48, B 2-54	1
	75-152-02	Power Harness, B 2-48	1
	98-599-15	Plastic grommet for 1.75 hole	
	98-599-20	Plastic Grommet for 2.5 hole	
	75-148-80	Harness for Pole Mounted Strobe Light	1
	75-107-10	Portable Charger Harness	1
	76-013-00	Portable Charger Receptacle	1
	75-152-90	Harness, Smart View display	1
1	73-005-05	Reverse Warning alarm	1
2	96-650-01	Wire Harness Clip, stick on	
3	96-642-00	Wire ahness Clip, push mount	
4	62-033-48	Accelerator Module	1
5	71-122-20	Horn Switch	1
6	88-065-06	1/4-NC x 21/2 Phillips Truss Head Screw, Horn Switch	2
7	88-069-81	1/4-NC Hex Nylon Locknut, Horn Switch	2
8	71-111-00	Brake Light Switch	1
9	88-045-06	10-32 x 1/2 Machine Screw, brake light switch	2
10	71-102-10	Seat interlock Switch	1
11	85-030-00	Spring	2
12	96-773-10	Clevis Pin	2
13	02-610-18	Mounting Plate	1
14	88-527-11	Cotter Pin	2
15	96-640-00	Clamp, 3/16 Push Mount	
16	96-629-80 (not shown)	Clamp, Rubber Lined 3/16 ID	
	96-630-00 (not shown)	Clamp, Rubber Lined 5/8 ID	
	96-630-50 (not shown)	Clamp, Rubber Lined 5/8 ID (.265 mounting hole)	
	96-631-00 (not shown)	Clamp, Rubber Lined 3/4 ID	
	96-631-10 (shown)	Clamp, Rubber Lined 1.0 ID	
	96-631-15 (not shown)	Clamp, Rubber Lined 1-1/2 ID	
17	96-624-00	Clamp, 1/4 Jiffy Clip	
	96-625-00 (not shown)	Clamp, 5/16 Jiffy Clip	
18	96-626-00	Clamp, 7/8 Jiffy Clip	



Lighting

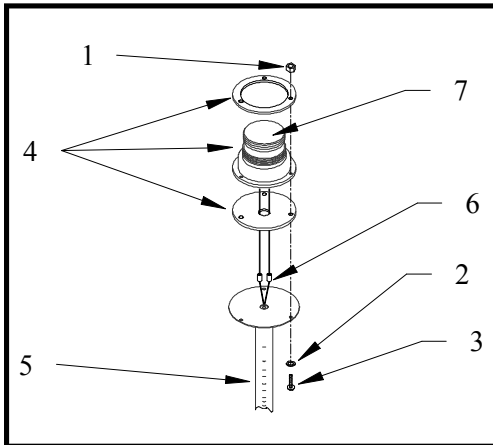

Stobe Light

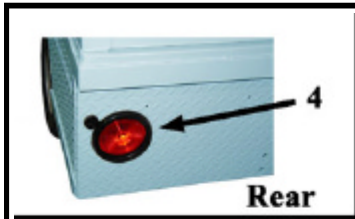

Strobe Light			
ITEM #	PART #	DESCRIPTION	QTY
1	88-029-80	8-32 Hex nut	3
2	88-028-62	#8 lock washer	3
3	88-025-06	8-32 x 1/2 Machine screw	3
4	72-023-20	Strobe assembly (amber)	1
5	**	Mounting pole	1
6	**	Harness	1
7	72-023-22	Amber lens	1
	72-023-23	Red lens	1
Not shown	72-023-21	Replacement bulb	1

** -There are many special order types of mounting pole configurations. Contact your Taylor-Dunn distributor with the serial number of the vehicle for more information.

Head and Tail Lights			
ITEM #	PART #	DESCRIPTION	QTY
1	72-005-00	5" Round head light	1 or 2
	72-072-00	Replacement bulb	1 or 2
2	94-050-10	Rectangular light , left (steel cab)	1
	94-050-11	Rectangular light , right (steel cab)	1
	72-082-01	Replacement bulb	2
3	94-201-10	Name plate	1
4	72-022-00	Tail light	1 or 2
	72-022-51	Tail ligh rubber grommet	1 or 2
	72-022-52	Tail light pigtail	

Turn Signals			
ITEM #	PART #	DESCRIPTION	QTY
-	72-051-00	Front lights(standard cowl)	2
-	72-082-10	Front bulb (steel cab)	2
-	72-082-20	Light socket (steel cab)	2
-	71-141-22	Turn signal switch	1
-	71-900-05	Flasher	1
-	72-405-00	Front light guard (standard cowl)	1



Lestronic® Charger (page 1)

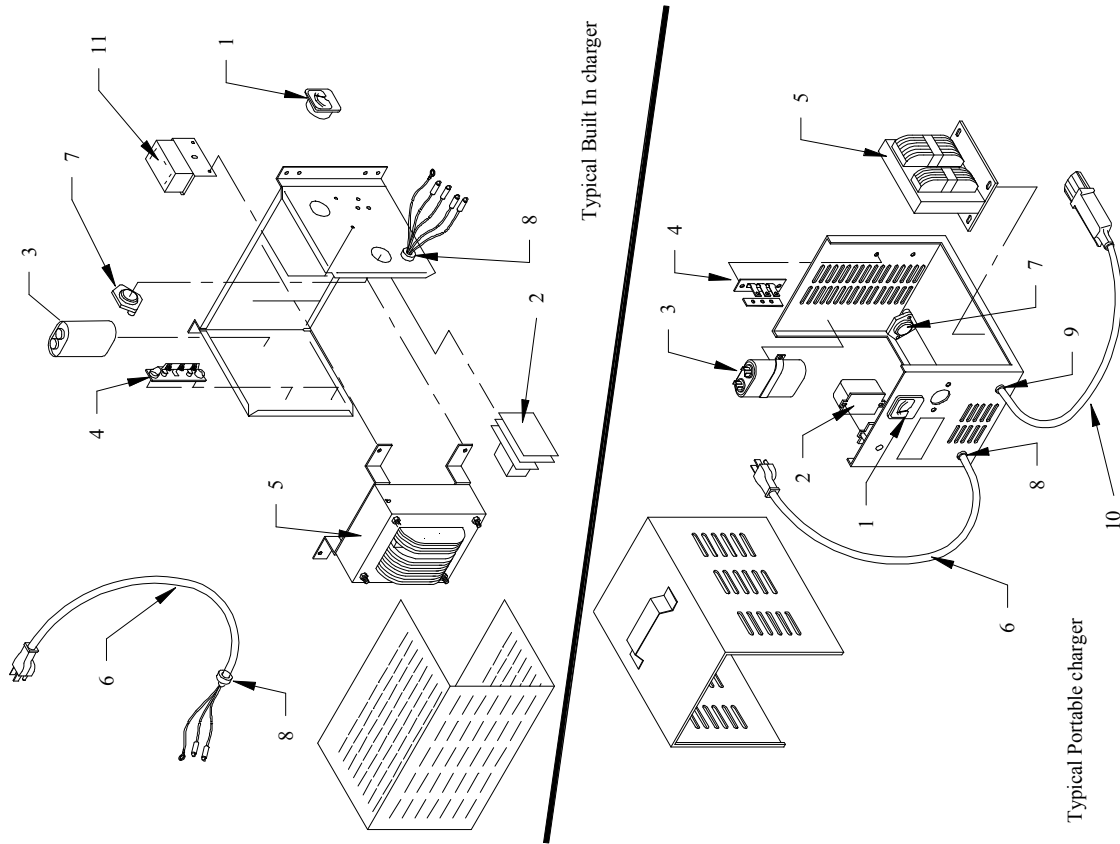

CHARGERS													
ITEM #	DESCRIPTION	Charger Model # Charger Part #											
		22740 79-303-15	7710-32 79-305-20	11860 79-304-65E	22640 79-303-20	9695 79-309-00	9475-31 79-306-21	16910 79-309-10	22620 79-303-25	16920 79-309-20	36LC25-8ET 115/60/12	36LC40-8ET 150/60/16	48LC25-8ET 115/60/15
	Charger Type	36LC25-8ET	36LC25-8ET	36LC25-8ET	36LC40-8ET	48LC25-8ET	36LC40-8ET	48LC25-8ET	36LC40-8ET	115/60/17	48/25	48/25	48LC25-8ET
	AC Voltage/Amps	115/60/12	115/60/12	230/50/na	150/60/16	115/60/15	150/60/16	115/60/15	115/60/17	115/60/15	48/25	48/25	115/60/15
	DC Voltage/Amps	36/25	36/25	36/25	36/40	48/25	36/40	48/25	36/40	36/40	48/25	48/25	48/25
	Style	Built-In	Portable	Built-In	Built-In	Portable	Built-In	Portable	Portable	Built-In	Built-In	Built-In	Built-In
1	Ammeter	-	79-851-10	79-851-10	79-852-00	79-851-10	79-852-00	79-851-10	79-852-00	-	-	-	-
2	Timer Assembly	79-805-67	79-805-69	79-805-72	79-805-67	79-805-65	79-805-67	79-805-65	79-805-67	79-805-68	79-805-68	79-805-68	79-805-68
	Relay for #2	79-808-00	79-808-00	79-808-00	79-808-00	79-808-20	79-808-00	79-808-20	79-808-00	79-808-20	79-808-20	79-808-20	79-808-20
3	Capacitor	79-902-00	79-902-00	79-902-00	79-902-00	79-902-00	79-902-00	79-902-00	79-902-00	79-902-00	79-902-00	79-902-00	79-902-00
4	Diode Assembly	79-749-13	79-749-13	79-749-11	79-749-10	79-749-13	79-749-10	79-749-13	79-749-10	79-749-13	79-749-13	79-749-13	79-749-13
5	Transformer	79-644-31	S/O	S/O	S/O	S/O	S/O	S/O	S/O	S/O	S/O	S/O	S/O
6	AC Cord	-	S/O	-	-	79-575-10	-	79-575-10	79-575-10	-	-	-	N/A
7	Fuse Assembly	79-831-00	79-831-00	79-831-00	79-831-10	79-831-00	79-831-10	79-831-00	79-831-00	79-831-00	79-831-00	79-831-00	79-831-00
8	Strain Relief	79-530-00	79-531-00	79-530-00	79-530-00	79-730-00	79-530-00	79-730-00	79-530-00	79-530-00	79-530-00	79-530-00	79-530-00
9	Strain Relief	-	79-530-00	-	-	79-730-00	-	79-730-00	79-531-00	-	-	-	-
10	DC Cord	-	79-566-10	-	-	79-566-10	-	79-566-10	S/O	-	-	-	-
11	Interlock Relay Assy.	79-809-60	-	79-306-23	79-809-50	-	79-809-50	-	-	-	-	-	79-809-50
-	Replacement AC Plug	76-200-00	76-200-00	-	76-200-00	76-200-00	76-200-00	76-200-00	76-200-00	76-200-00	76-200-00	76-200-00	76-200-00



Lestronic® Charger (page 2)

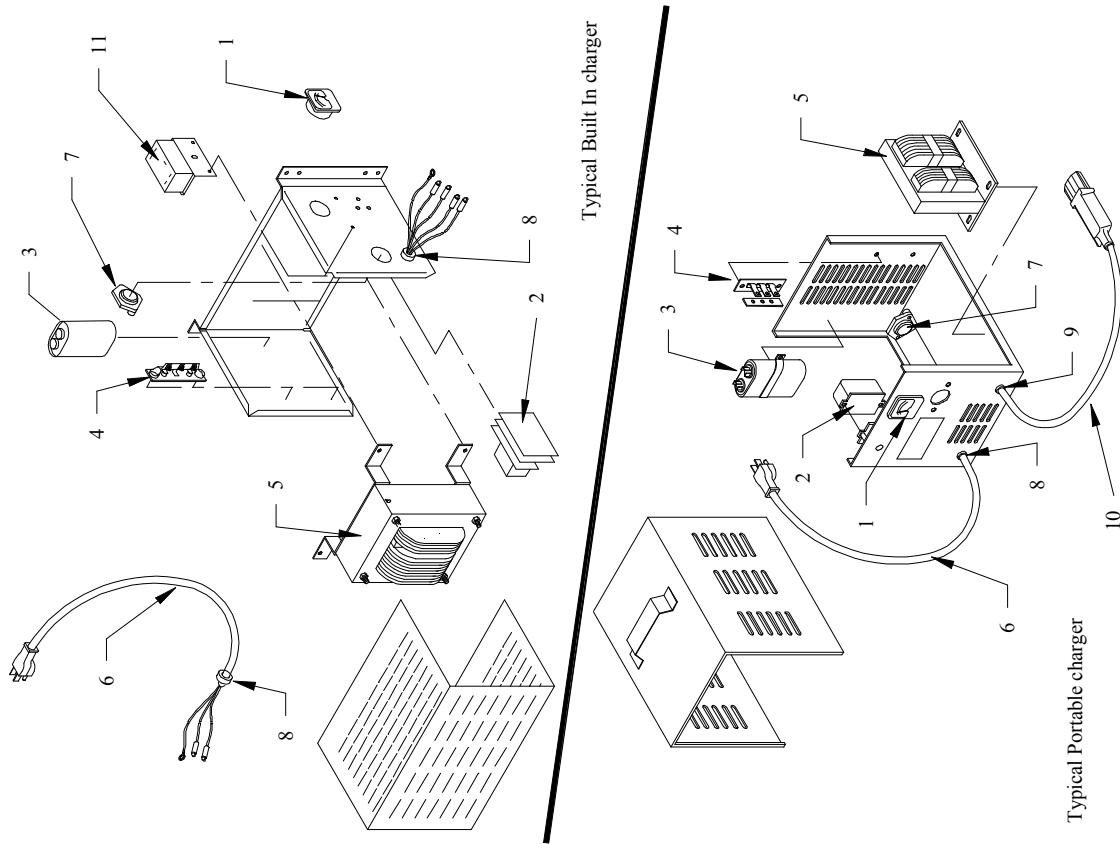

CHARGERS										
ITEM #	DESCRIPTION	Charger Model # Charger Part #								
		14400-31 79-302-50	7105-01 79-300-50	12750 79-300-55E	13110 79-301-10	9513-31 79-302-10	13760 79-302-15	22730 79-303-05	7030 79-304-60	12315 79-306-90
	Charger Type	24LC40-8ET	24LC25-8ET	24LC25-8ET	24LC25-8ET	24LC40-8ET	24LC25-8ET	24LC40-8ET	24LC25-8ET	36LC40-8ET
	AC Voltage/Hz/Amps	230/50/7	230/50/4	230/50/4	115/60/9	115/60/13	115/60/8	115/60/13	230/50/7	230/50/8
	DC Voltage/Amps	24/40	24/25	24/25	24/25	24/40	24/25	24/40	36/25	36/40
	Style	Portable	Portable	Built-In	Portable	Portable	Built-In	Built-In	Portable	Portable
1	Ammeter	79-852-00	79-851-10	-	79-851-10	79-852-00	-	-	79-851-10	79-852-00
2	Timer Assembly	S/O	79-805-64	79-805-70	79-805-64	79-805-64	79-805-66	79-805-66	K4-071-87	K4-071-87
	Relay for #2	79-808-10	79-808-10	79-808-10	79-808-10	79-808-10	79-808-10	79-808-10	79-808-00	79-808-00
3	Capacitor	79-902-00	79-902-00	79-902-00	79-902-00	79-902-00	79-902-00	79-902-00	79-902-00	79-902-00
4	Diode Assembly	S/O	79-749-13	79-749-13	S/O	79-749-13	79-749-13	79-749-13	79-749-13	79-749-10
5	Transformer	S/O	S/O	79-644-08	S/O	S/O	S/O	S/O	S/O	S/O
6	AC Cord	S/O	S/O	-	S/O	79-575-10	-	-	S/O	S/O
7	Fuse Assembly	79-831-10	79-831-00	79-831-00	79-831-00	79-831-10	79-831-10	79-831-10	79-831-00	79-831-00
8	Strain Relief	S/O	79-532-00	79-530-00	79-532-00	79-531-00	79-531-00	79-531-00	79-532-00	79-532-00
9	Strain Relief	S/O	79-530-00	-	79-530-00	79-530-00	-	-	79-530-00	79-530-00
10	DC Cord	79-567-10	79-566-10	-	79-566-10	S/O	-	-	S/O	79-567-10
11	Interlock Relay Assy.	-	-	79-306-23	-	-	79-809-60	-	-	-
-	Replacement AC Plug	-	-	-	76-200-00	76-200-00	76-200-00	76-200-00	-	-



Signet® Charger



Model HBS series charger shown

Model HBS for Flooded Batteries	
PART #	DESCRIPTION
*	24 volt Charger Assembly (see note)
79-303-41	36 volt Charger assembly (see note)
79-309-42	48 volt charger assembly (see note)

Model HB for Flooded Batteries	
PART #	DESCRIPTION
79-302-20	24 volt Charger Assembly (see note)
79-303-40	36 volt Charger assembly (see note)
79-309-40	48 volt charger assembly (see note)

Model HBS for GEL Batteries	
PART #	DESCRIPTION
*	24 volt Charger Assembly (see note)
*	36 volt Charger assembly (see note)
*	48 volt charger assembly (see note)

Model HB for GEL Batteries	
PART #	DESCRIPTION
*	24 volt Charger Assembly (see note)
K4G-CH-003	36 volt Charger assembly (see note)
79-309-41	48 volt charger assembly (see note)

* - Not available at time of printing

NOTE: There are no user serviceable components inside the charger

*NOTE: The charger AC cord is an intergral part of the charger. When replacing the charger, do not cut and splice the AC cord. **Cutting the AC cord will void the charger warranty.***

NOTE: The Signet model HBS series charger replaces all previous Signet models.

NOTE: The harness connectors and AC plug are not included with the charger.

QTY	PART #	DESCRIPTION
2	75-318-20	Butt splice
2	75-320-51	Knife connector
1	76-200-00	AC plug, 115v domestic

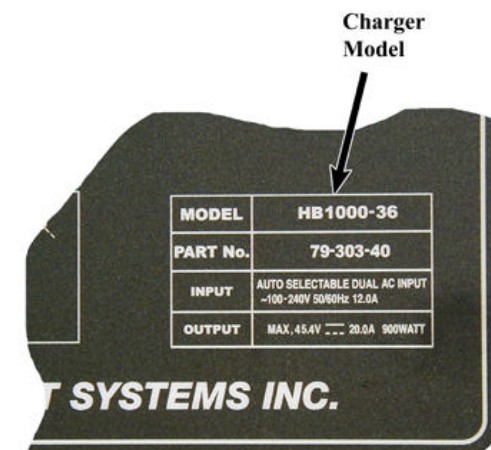

Typical Data Plate (your data plate may be different)



Batteries

Depending on the configuration of your vehicle, the batteries may be wired as shown in these two illustrations.

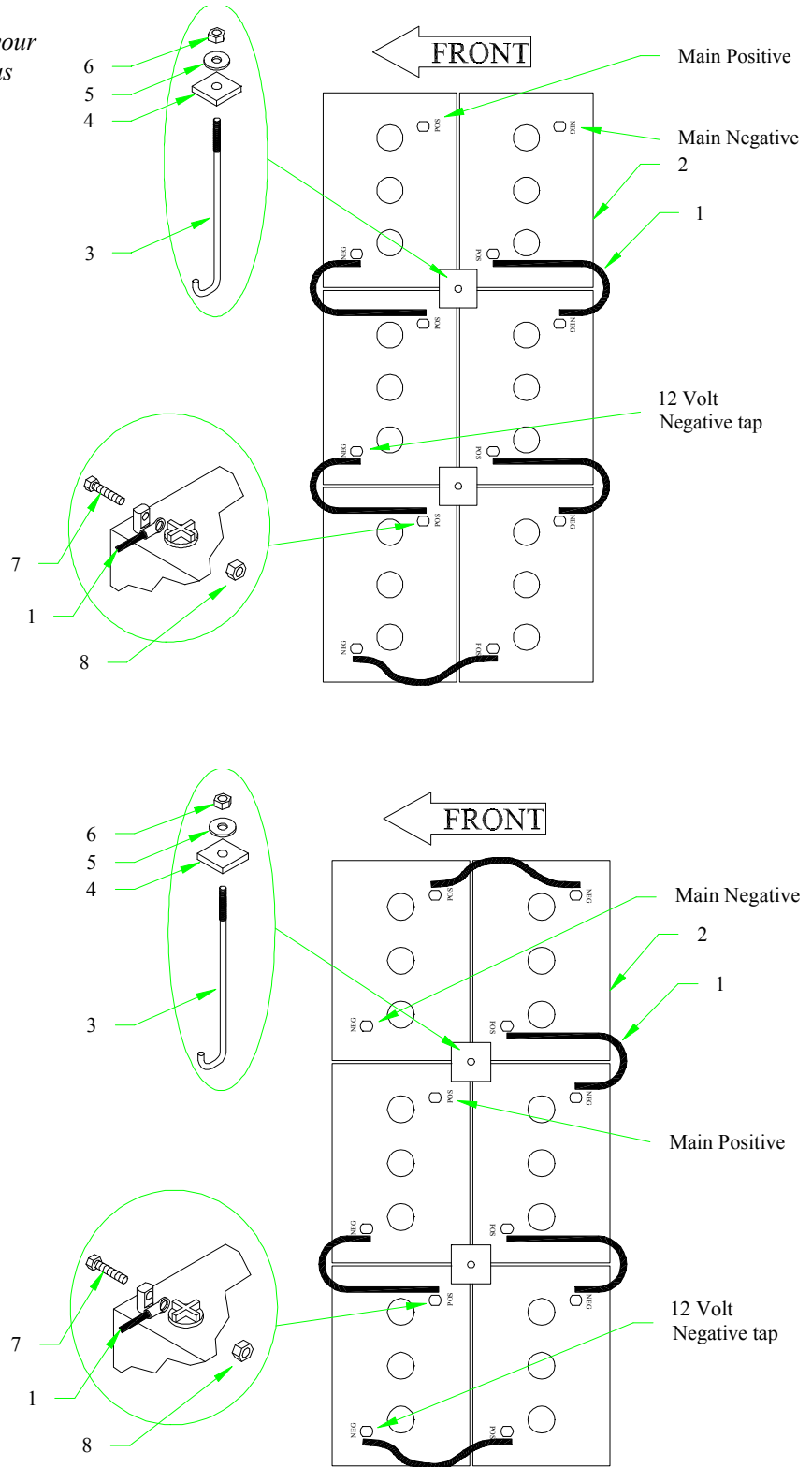

Batteries			
ITEM #	PART #	DESCRIPTION	QTY
1		Batteru jumper	**
2	77-042-00	217AH, T-105	**
	77-042-50	217AH, TD-217	**
	77-042-80	217AH, T-105 Moist charge (dry)	**
	77-044-00	230AH, T-125	**
	77-044-10	195AH, Mainenance free (Note: requires special charger)	**
	77-047-00	244AH, T-145	**
	77-047-50	250AH, TD-250	**
	77-047-80	244AH, T-145 Moist charge (dry)	**
	77-048-00	250AH, J-250	**
	77-048-80	250AH, J-250 Moist charge (dry)	**
	77-051-00	160AH Gell (Note: requires special charger)	**
3	50-243-10	Battery rod	**
4	50-250-00	Battery hold down	**
5	88-088-66	Flat washer, tin/lead plated	**
6	88-069-81	1/2NC Nylon lock nut	**
7	88-081-12	5/16NC x 1 Hex bolt, stainless steel	**
8	88-089-80	5/16NC Hex nut, stainless stell	**
**	Quantities depend on voltage configuration of vehicle.		



Seat Cushions and Deck, B 2-48 and B 2-54



B 2-48 and B 2-54 Seats and Deck			
ITEM #	PART #	DESCRIPTION	QTY
1	90-148-00	Passenger seat cushion (standard)	1
	90-172-00	Passenger seat cushion (with steel cab)	1
2	90-140-00	Seat back (standard)	1
	90-179-00	Seat back (with steel cab)	1
3	90-148-00	Driver seat cushion (standard)	1
	90-172-00	Driver seat cushion (with steel cab)	1
4	90-444-00	Deckboard, 75-1/4 x 41 (standard bed)	1
	90-466-10	Deckboard, 19-1/2 x 41	1
	90-467-10	Deckboard, 55-3/4 x 41	1
	90-466-00	Deckboard, 21-3/4 x 41 (fold away seat option)	1
	90-468-00	Deckboard, 32-3/4 x 41 (fold away seat option)	1
	90-469-00	Deckboard, 19-11/16 x 41 (fold away seat option)	1
	90-464-00	Deckboard, 55 x 41 (fold away seat option)	1
	90-441-00	Deckboard, 37-1/2 x 41	1
	90-440-43	Diamond plate deck cover, 32-3/4 x 41	1
	90-440-50	Diamond plate deck cover, 19-1/2 x 41	1
	90-440-54	Diamond plate deck cover, 55-3/4 x 41	1
	88-607-09	Rivet, diamond plate deck	-
	95-530-10	Handle, fold away seat	1
5	90-140-00	Seat back	1
	90-107-01	Seat frame	1
6	90-134-00	Seat cushion	1
7	90-108-01	Rear step	1
8	90-134-00	Seat cushion	1
9	90-140-00	Back rest	1
10	90-542-01	End gate	1
	90-542-06	Left gate, 75"	1
	90-542-05	Right gate, 75"	1
	90-542-03	Left gate, 37-1/4"	1
	90-542-02	Right gate, 37-1/4"	1
	90-542-04	Left gate, 37-1/2"	1
	90-542-07	Right gate, 37-1/2"	1
11	90-101-50	Seat frame, lower (unpainted)	1
	90-101-51	Seat frame, upper (unpainted)	1



Seat Cushions BT 2-48



Shown with optional top and windshield

Seat Cushions BT 2-80



Shown with optional seat belts

BT 2-48 Seats (black)			
ITEM #	PART #	DESCRIPTION	QTY
1	90-195-00	Rear seat back	4
	02-203-14	Seat back mounting plate	4
	88-837-11	#14 x 1 Sheet metal screw	30
2	90-194-00	Rear seat cushion	4
3	90-140-00	Front seat back	1
4	90-148-00	Front seat cushion	2

BT 2-80 Seat Cushions (black)			
ITEM #	PART #	DESCRIPTION	QTY
1	90-165-20	Front driver seat chshion	1
2	90-165-20	Front passenger seat cushion	1
3	90-132-00	Backrest	3
4	90-165-20	Rear seat cushion	2
Not shown	88-837-11	#14 x 1 Phillipsscrew	12



Decals

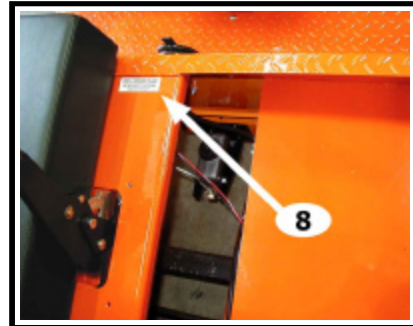
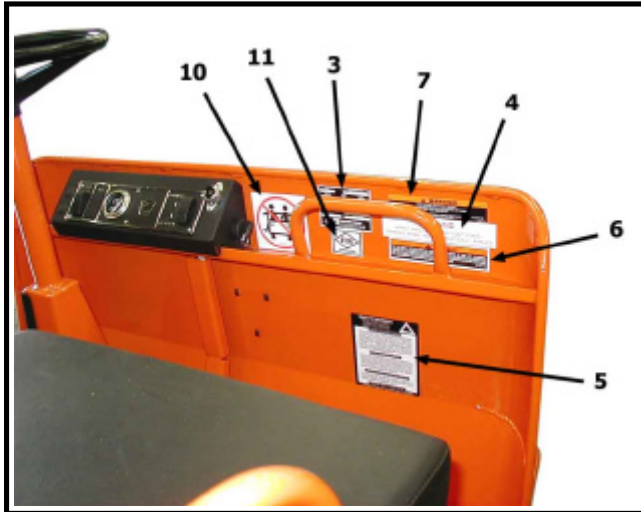

Between seats

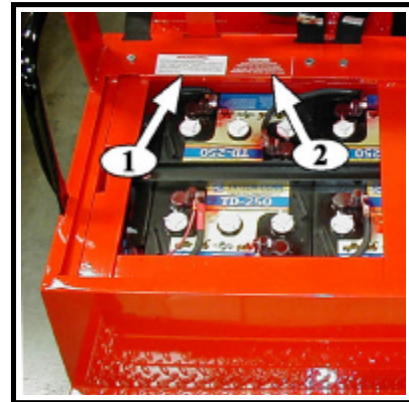

BT 2-80 under 2nd seat

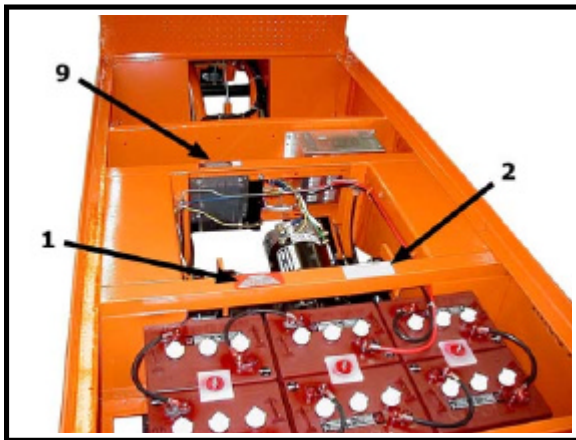

B 2-48 and B 2-54

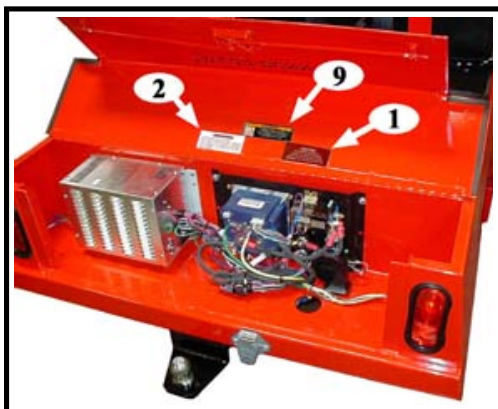

BT 2-80 electronics compartment

Decals			
ITEM #	PART #	DESCRIPTION	QTY
1	94-319-00	Battery disconnect	1 or 2
2	94-313-00	Battery warning	1 or 2
3	94-373-10	Vehicle identification	1
4	94-309-00	Brake warning	1
5	94-313-20	Safety warning	1
6	94-384-01	Not a motor vehicle	1
7	94-384-14	When leaving vehicle warning	1
8	94-301-41	Brake fluid	1
9	94-384-17	Do not wash	1
10	94-301-42	Arms and legs	1
11	94-333-00	FM	1



Cab Options



Steel Cab

Fiberglass cab



Steel Cab			
ITEM #	PART #	DESCRIPTION	QTY
-	91-012-00	Steel cab (unpainted)	1
-	90-852-30	Front windshield	1
-	90-850-10	Rear window	1
-	98-310-00	Rubber windshield gasket (by the foot)	-

Fiberglass Cab			
ITEM #	PART #	DESCRIPTION	QTY
-	91-000-00	Fiberglass cab	1
-	90-800-00	Front windshield	1
-	90-850-00	Rear window	1
-	98-310-10	Rubber windshiel gasket (by the foot)	-
-	94-035-01	Plastic door trim (by the foot)	-
-	90-908-50	Filler panel	2



Door Options, Steel Cab

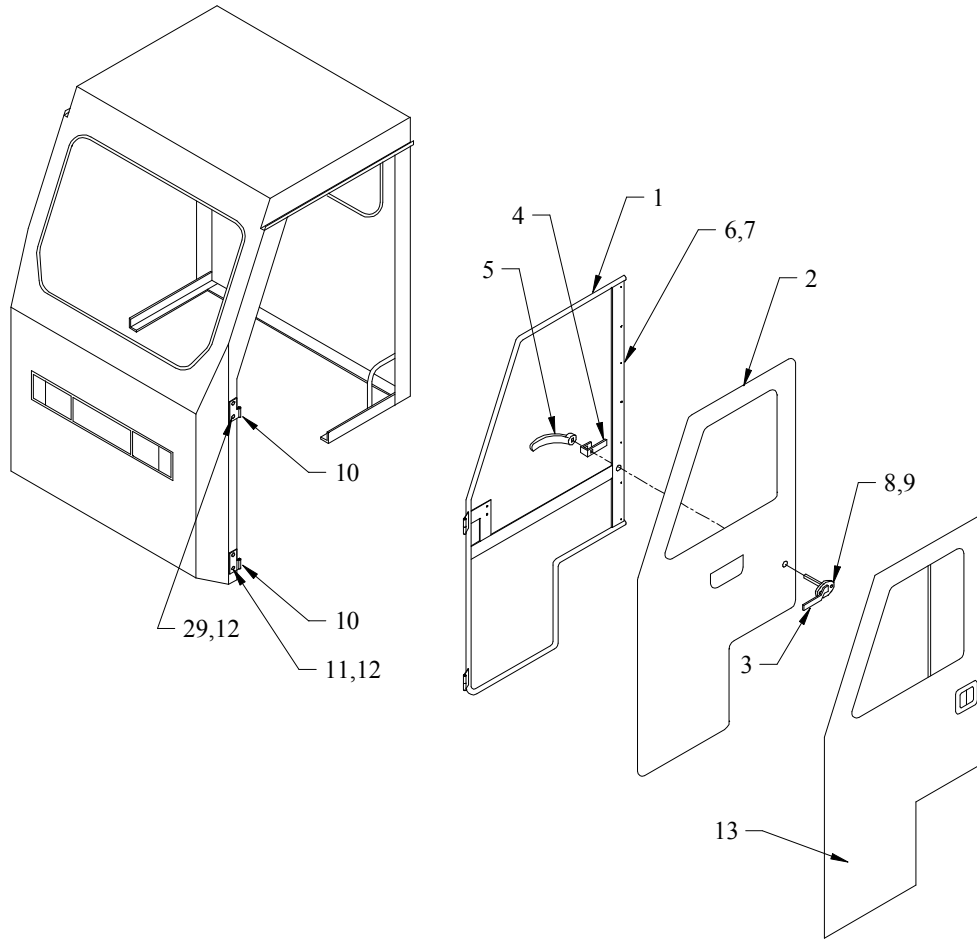

Steel door detail
Note: Left Door Shown

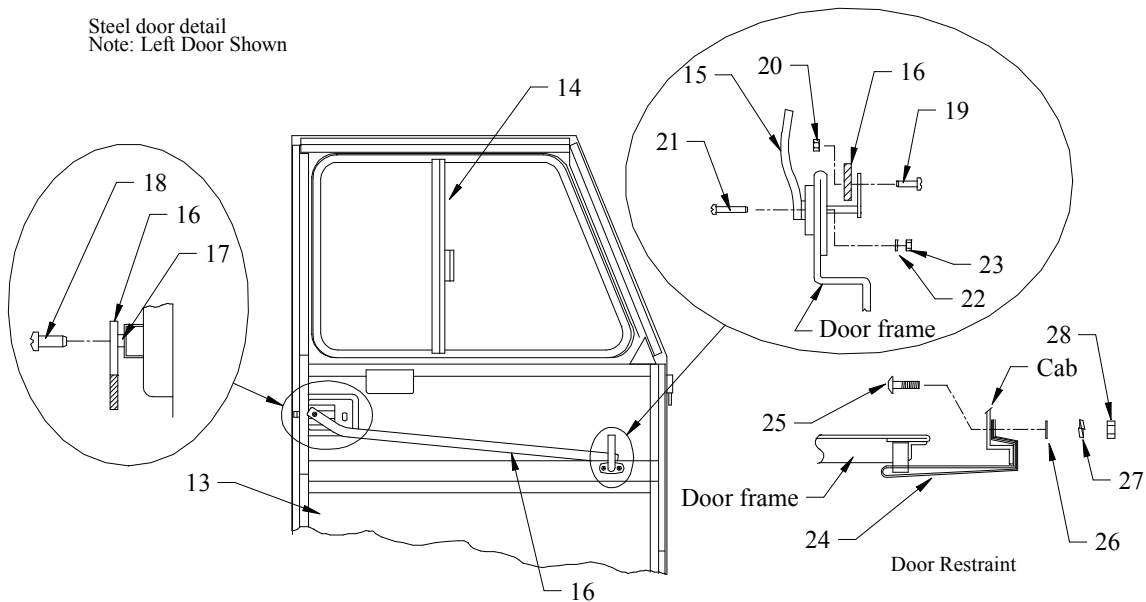

Cab Doors Naugahyde (Steel cab)			
ITEM #	PART #	DESCRIPTION	QTY
1	90-923-98	Door Frame, Left	1
Not shown	90-923-99	Door Frame, Right	1
2	90-924-98	Side Curtain, Left	1
Not shown	90-924-99	Side Curtain Right	1
3	97-315-53	Handle Assembly, Outer	2
4	97-315-51	Door Latch	2
5	97-315-54	Handle Assembly Inside	2
6	97-303-03	Snap Fastner	14
7	88-727-06	Rivet, 5/32 X 5/8"	14
8	88-025-08	Locknut, #8-32"	4
9	88-029-86	Screw, #8-32 X 5/8", Truss Head	4
10	91-814-10	Hinge, Female, Left	2
Not shown	91-814-11	Hinge, Female, Right	2
11	88-082-09	Bolt, 5/16 X 5/8", Carriage	8
12	88-089-81	Locknut, 5/16" NC	8

Cab Doors Steel (Steel cab)			
ITEM #	PART #	DESCRIPTION	QTY
13	91-011-66	Kit, Cab Door, Left, Specify Color (includes #10, 11,12)	1
	91-011-68	Kit, Cab Door, Left, Orange (includes #10, 11,12)	1
Not Shown	91-011-67	Kit, Cab Door, Right, Specify Color (includes #10, 11,12)	1
Not Shown	91-011-69	Kit, Cab Door, Right, Specify Color (includes #10, 11,12)	1
14	90-853-10	Window, Left	1
Not Shown	90-853-11	Window, Right	1
15	97-315-58	Door Handle, Inner	2
16	91-012-12	Connecting Bar	2
17	16-510-00	Spacer	2
18	88-065-06	Screw, 1/4 X 1/2" NC, Phillips Truss Head	2
19	88-045-08	Screw, #10-32 X 5/8", Truss Head	2
20	88-049-86	Locknut, #10-32	2
21	88-045-11	Screw, #10-32 X 1", Truss Head	4
22	88-048-62	Lock Washer, #10	4
23	88-049-80	Nut, #10-32	2
24	91-012-45	Strap, Door Restraint	2
25	88-082-11	Bolt, 5/16 NC X 1" Carriagee	2
26	88-088-60	Washer, 5/16 Cut	2
27	88-088-62	Lock Washer, 5/16"	2
28	88-089-83	Acorn Nut, 5/16" NC	2
29	91-011-31	Door Weldment, Left (unpainted)	1
Not Shown	91-011-32	Door Weldment, Right (unpainted)	1



Door Options, Fiberglass Cab

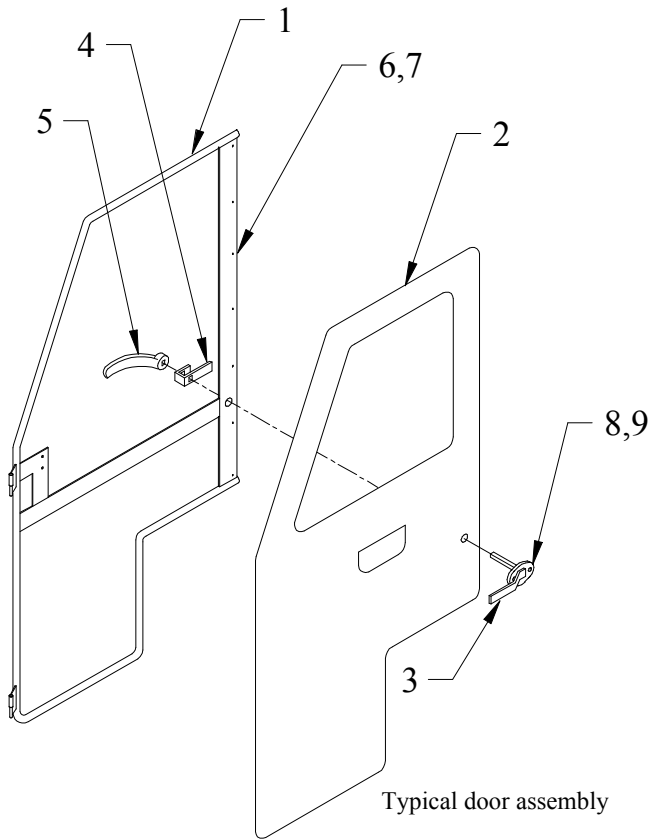

Cab Doors Naugahyde (fiberglass cab)			
ITEM #	PART #	DESCRIPTION	QTY
1	90-921-98	Door Frame, Left	1
	90-921-99	Door Frame, Right	1
	98-451-11	Weather seal tape (by the foot)	-
2	90-908-98	Side Curtain, Left	1
	90-908-99	Side Curtain Right	1
3	97-315-53	Handle Assembly, Outer	2
4	97-315-51	Door Latch	2
5	97-315-54	Handle Assembly Inside	2
6	97-304-50	Snap Fastner	12
7	88-737-08	Rivet, 5/32 X 5/8"	14
8	88-029-86	Locknut, #8-32"	4
9	88-025-08	Screw, #8-32 X 5/8", Truss Head	4
10	-	-	-
11	-	-	-
12	-	-	-
13	-	-	-
14	94-036-00	Drip moulding	1
15	91-810-00	Lower hinge	2
	17-104-00	Collar	2
16	91-809-10	Upper hinge	2



Hydraulic Dump Body Option

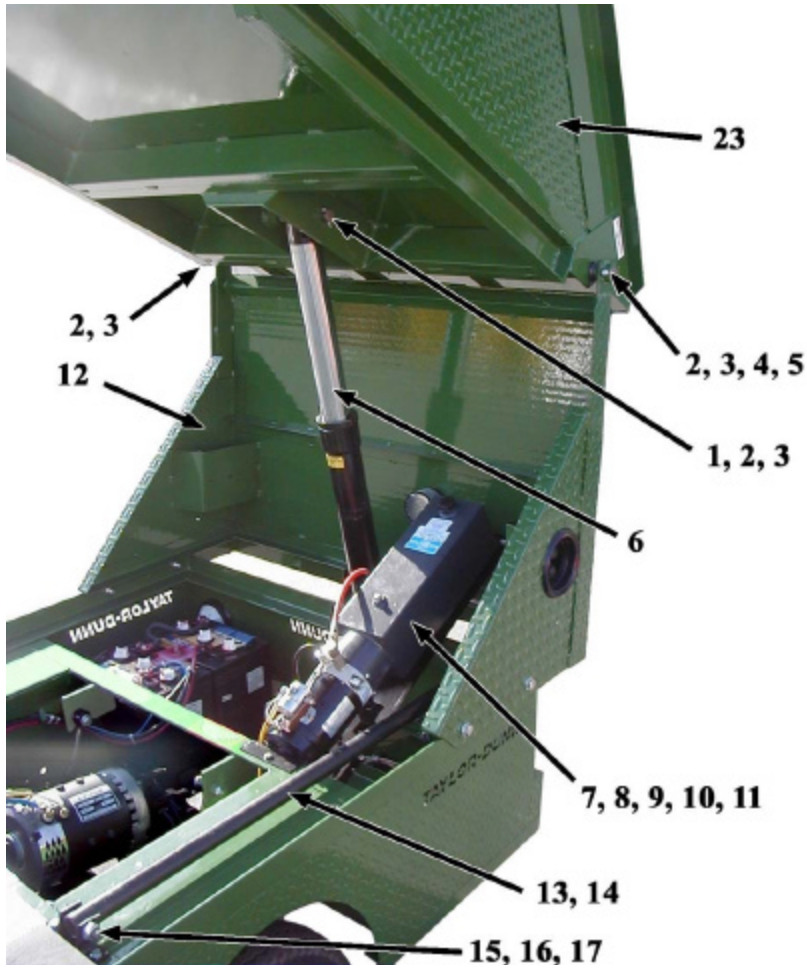

22 (rubber cap)



22 (plastic housing)



Dump Bed Option			
<i>ITEM #</i>	<i>PART #</i>	<i>DESCRIPTION</i>	<i>QTY</i>
1	21-018-00	Cylinder Pin	1
2	88-060-11	Bolt, 1/4 X 1-1/4" NC, Hex Head	6
3	88-069-81	Locknut, 1/4" NC	6
4	21-019-00	Shaft, Dump Bed Pivot	2
5	17-112-00	Collar, Shaft	2
6	99-524-00	Hydraulic Cylinder	1
7	99-957-00	Hydraulic Pump and Motor	1
8	99-597-09	Bracket, Hydraulic Pump	1
9	88-100-11	Bolt, 3/8 X 1" NC, Hex Head	3
10	88-109-81	Locknut, 3/8" NC	3
11	98-753-08	Isolator Mount, Rubber	3
12	91-286-01	Carrier Frame, Dump Bed	1
13	91-285-11	Safety Prop Rod	1
14	98-754-00	Rubber Bumper, Safety Prop Rod	1
15	91-285-10	Bracket, Safety Prop Rod	1
16	96-244-00	Bolt, 1/2" NC, Hex Head with Grease Fitting	1
17	88-149-81	Locknut, 1/2" NC, Hex Head	1
21	72-022-51	Rubber Mounting Ring	1
22	71-102-15	Switch (rubber cap)	2
	71-102-16	Switch (plastic housing)	2
23	91-285-01	Dump Bed	1
Not shown	90-442-00	Deckboard	1
	AA-000-11	Fluid, Hydraulic, Dextron 2, Quart	1
	75-124-00	Wire Harness	1
	See below	Buss Bar, Circuit Breaker	
	See below	Circuit Breaker	
	99-526-11	Fitting, Adapter 3/8 X 3/8 NPTF	1
	99-527-01	Fitting, Adapter 90°	2
	99-597-50	Bracket, Hydraulic Pump	1
	99-597-51	Hose Assemble, 24"	1
	72-510-00	Solenoid, Pump (metal can)	1
72-510-10	Solenoid, Pump (plastic can)	1	

Circuit Breaker Usage:

Up to serial number 175999 use:

- 79-843-00 Circuit breaker 1 each
- 78-106-00 Buss bar 2 each
- 71-610-02 Mounting bracket 1 each

Starting with serial number 176000 use:

- 79-843-01 Circuit breaker 1 each

Contact the pump manufacturer for internal parts for the pump assembly.

<http://www.monarchhyd.com/>

The pump assembly model number is: M-303



Rear Cargo Box

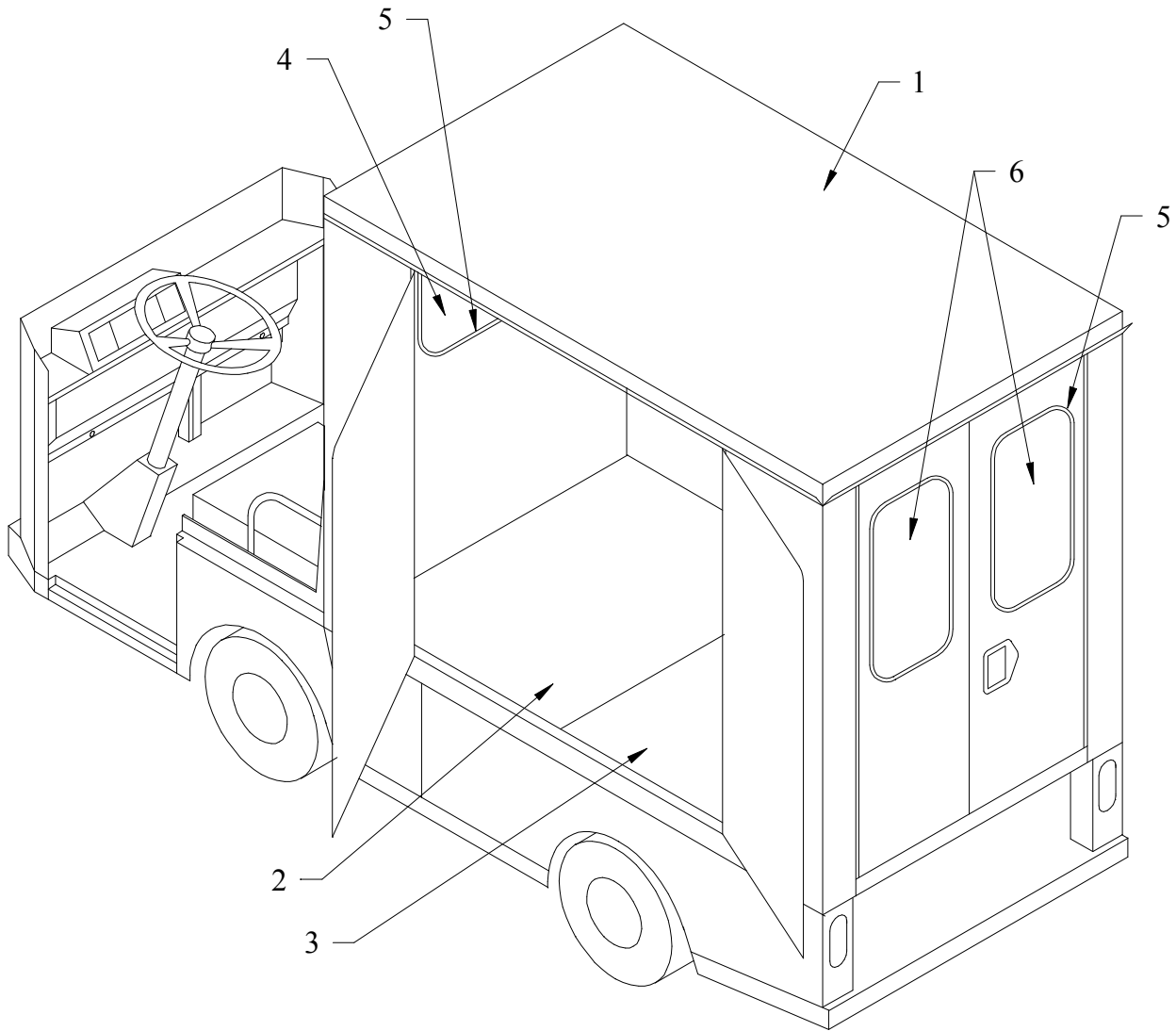

Rear Cargo Box			
ITEM #	PART #	DESCRIPTION	QTY
1	91-333-02	Cargo box (unpainted)	1
2	90-471-00	Front deck board	1
3	90-472-00	Rear deeck board	1
4	90-850-10	Front window	1
5	98-310-00	Ruber window gasket (by the foor)	-
6	90-851-00	Rear window	2
Not shown	94-320-10	Load line decal	1
	00-210-23	Deck support angle	1



Hitches

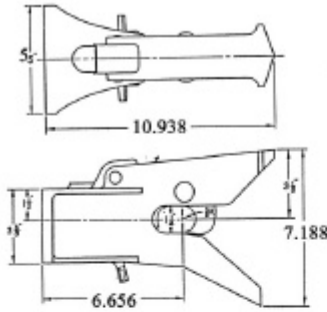

97-808-00
Automatic Coupling Hitch

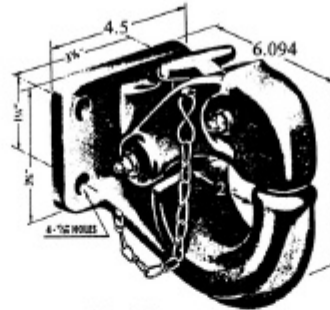

97-804-01
Pintle Hitch

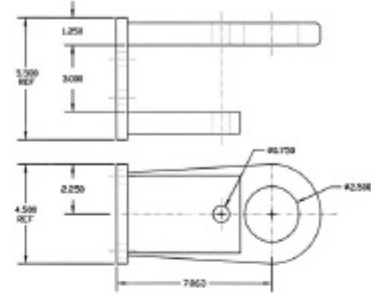

Hook Pin and Eye Hitch
97-809-00

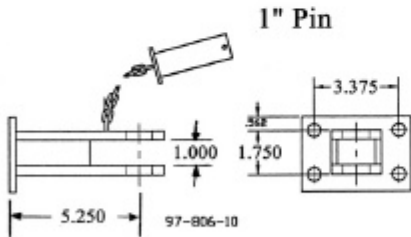

97-806-10
Pin and Clevis Hitch

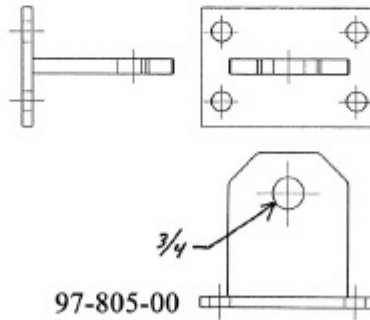

97-805-00
Ball Hitch Mount

APPENDIX A-Special Tools

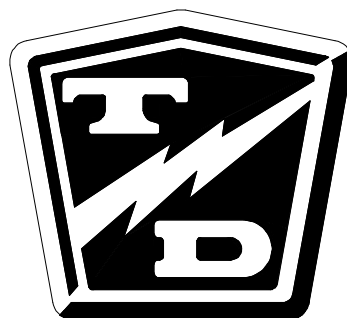

Special Tools

<u>DESCRIPTION</u>	<u>PURPOSE</u>	<u>PART NUMBER</u>
Pinion Seal Installation Tool	Used to install the pinion seal on all chain drive trucks with the band style brake or the speed sensor on the chain case cover.	43-201-50
Chain Case Centering Tool	Used to center the chain case on the pinion shaft on all chain drive trucks with the band style brake or the speed sensor on the chain case cover. Includes instructions.	41-532-50
Test Light	Used for testing electrical circuits. Powered by the truck batteries, switchable for 12, 24, 36, and 48 volts.	62-027-00
Accelerator Test Harness	Used to test the solid state accelerator module part number series 62-033-XX.	62-027-31
PMC Test Kit	Includes 62-027-00, 62-027-31, and supplementary troubleshooting manual M3-001-06. For controllers equipped with pins labeled KSI and #2 only.	62-027-60
Curtis® PMC Handheld Programmer	Used to test and program the 62-215-00 PMC speed control used on early model C4-25 Huskey.	62-027-10
GE® EV1 Analyzer	Used to test the GE® EV1 speed control.	62-027-20
PMT/C Meter Reset Module	Used to reset the PMT/C maintenance meter after a maintenance is completed.	96-500-43
Sevcon® Handset Analyzer (read only)	Used to test the Sevcon® control systems and reset the Smart View display (includes instructions).	62-027-61
Sevcon® Handset Analyzer with Speed Adjust Capability	Same as 62-027-61 (above) plus allows a limited range of speed adjustment.	62-027-62
Disc Brake Boot Installation Tool	Used to install the rubber boot on all disc brake bodies.	41-350-13
Pin Removing Tool	Used to remove pins and sockets from AMP connectors.	75-440-55
Pin Removing Tool	Used to remove pins and sockets from MOLEX connectors.	75-442-55
Hydrometer	Used to check the specific gravity of battery electrolyte.	77-200-00
Battery Filler	Used to safely add water to batteries.	77-201-00
Retaining Plate Depressor	Used to hold down the retaining plate when disassembling the steering gear on trucks equipped with the tilt steering.	96-500-39
Fork Collar Weld Jig	Used when replacing the fork collar on models MX-600 and SSS-36.	96-500-40
Secondary Sheave Holder	Used to hold the secondary sheave (pulley) from turning on models R6-80 and B6-10 with the Yamaha drive.	96-500-14
Solder Kit For Field Stud	Used to solder the aluminum field wire to the field stud. For use on motors with soldered connections only.	70-210-63
Pinion Gear Holding Tool	Used to align the Pinion Gear and Case during assembly and disassembly.	96-500-42

Appendix B: Standard Hardware Suggested Torque Limits

TABLE OF CONTENTS

Hardware Identification	2
Standard Head Markings	2
Hex Bolts	2
Other Bolts	2
Hex Nuts	3
Hex Lock Nuts (stover)	3
Other Nuts	3
Suggested Torque Values	
(non-critical hardware)	4
Suggested Torque Values	
(critical hardware)	5

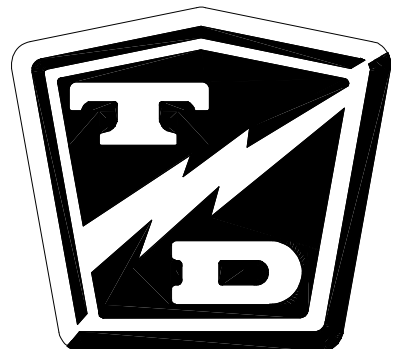



HARDWARE IDENTIFICATION

Standard Head Markings

NOTE: Torque value used should be for lowest grade of hardware used. If a grade 2 nut is used on a grade 8 bolt, use grade 2 torque value.

NOTE: Toque values specified are for clean dry threads.

Hex Bolts

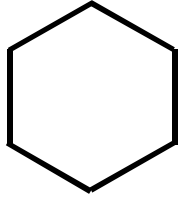

S.A.E. Grade 2

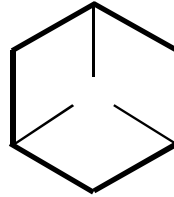

S.A.E. Grade 5

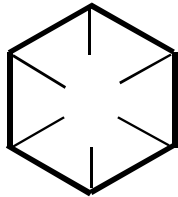

S.A.E. Grade 8

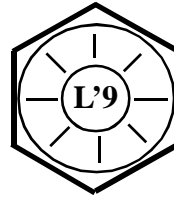

L'9

Other Bolts



Truss Head, grade 2



*Carriage Bolt, grade 2
(unless marked as above)*

Hex Nuts

Nuts with no markings are to be treated as S.A.E. Grade 2

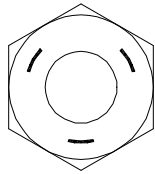
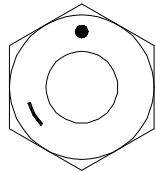
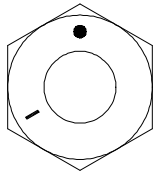

S.A.E. Grade 5

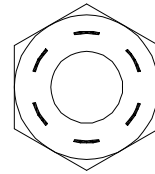
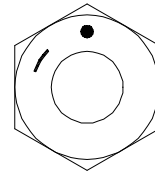
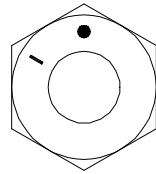

S.A.E. Grade 8

Hex Lock Nuts (stover)

Lock nuts use a letter to indicate the grade of the nut. Grade 'A' locknuts would be the equivalent of Grade '2' hex nuts, Grade 'B' as Grade '5' and Grade 'C' as Grade '8'.

NOTE: Nuts with no markings are to be treated as S.A.E. Grade A

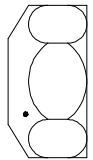
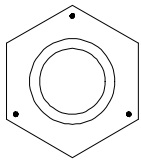

or,

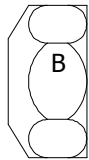

or,



S.A.E. Grade B

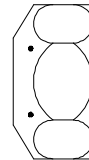
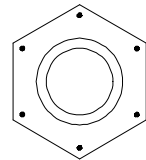

or,

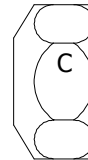

or,

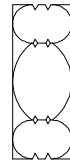

S.A.E. Grade C

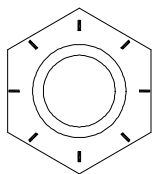

Grade L'9

Other Nuts

Other nuts used by Taylor-Dunn® should be treated as S.A.E. grade A



SUGGESTED TORQUE VALUES *(non-critical hardware)*

Diameter and TPI	Grade 2 Tightening Torque (ft-lb)	Grade 5 Tightening Torque (ft-lb)	Grade 8 Tightening Torque (ft-lb)	L'9 Tightening Torque (ft-lb)
1/4-20	4-7	7-10	10-14	11
1/4-28	5-8	8-12	11-16	12
5/16-18	9-14	14-21	20-29	22
5/16-24	10-15	15-23	22-33	25
3/8-16	16-24	25-37	35-52	40
3/8-24	18-27	28-42	40-59	45
7/16-14	26-38	40-59	56-84	65
7/16-20	29-43	44-66	62-93	70
1/2-13	39-59	60-90	85-128	95
1/2-20	44-66	68-102	96-144	110
9/16-12	56-84	87-131	123-184	140
9/16-18	63-94	97-146	137-206	160
5/8-11	78-117	120-180	170-254	195
5/8-18	88-132	136-204	192-288	225
3/4-10	138-207	213-319	301-451	350
3/4-16	154-231	238-357	336-504	390
7/8-9	222-334	344-515	485-728	565
7/8-14	245-367	379-568	534-802	625
1-8	333-500	515-773	727-1091	850
1-14	373-560	577-866	815-1222	930
1.125-7	472-708	635-953	1030-1545	1700
1.125-12	530-794	713-1069	1156-1733	1850
1.25-7	666-999	896-1344	1454-2180	2950
1.25-12	738-1107	993-1489	1610-2414	3330

SUGGESTED TORQUE VALUES (critical hardware)

Torque Table

Group	Description	Torque Range		
		Ft-Lbs	In-Lbs	Nm
<i>Brakes</i> - - - - -				
	Brake bolt (disc brake body)	11 - 11	132 - 132	15 - 15
	Brake line tube nut fittings	12 - 13	144 - 156	16.3 - 17.7
	Brake spider bolts (Dana 160mm hyd brakes)	25 - 35	300 - 420	34 - 47.6
	Brake spider bolts (Dana 160mm mech brakes)	15 - 19	180 - 228	20.4 - 25.8
	Brake spider bolts (Dana 7x1-3/4 brakes)	16 - 20	192 - 240	21.8 - 27.2
<i>Electrical</i> - - - - -				
	Battery terminals	8 - 9	96 - 108	10.9 - 12.2
<i>Front Axle</i> - - - - -				
	Front spindle nut	-	-	-
	<i>Note: Refer to maintenance section in the service manual</i>			
	King pin	-	-	-
	<i>Note: Refer to maintenance section in the service manual</i>			
<i>Rear Axle/Transmission</i> - - - - -				
	3rd member Gear case cover (GT drive)	45 - 50	540 - 600	61.2 - 68
	Axle bolt (GT drive)	275 - 275	3300 - 3300	374 - 374
	Axle hub nut (Dana)	95 - 115	1140 - 1380	129.2 - 156.4
	Axle tube to center section (Dana F-N-R)	25 - 35	300 - 420	34 - 47.6
	Carrier cap bolts (Dana)	100 - 120	1200 - 1440	136 - 163.2
	Differential Cover plate (Dana H12)	18 - 25	216 - 300	24.5 - 34
	Drain plug (Dana H12)	25 - 40	300 - 480	34 - 54.4
	Drain plug (GT drive)	21 - 25	252 - 300	28.6 - 34
	Gear case to 3rd member (GT drive)	18 - 20	216 - 240	24.5 - 27.2
	Motor mounting (GT/Dana)	6.5 - 7	78 - 84	8.8 - 9.5
	Pinion nut (F2/F3)	175 - 175	2100 - 2100	238 - 238
	Pinion nut (GT drive)	154 - 169	1848 - 2028	209.4 - 229.8
	Ring gear (Dana)	35 - 45	420 - 540	47.6 - 61.2
	Wheel lug nut	75 - 90	900 - 1080	102 - 122.4
<i>Steering</i> - - - - -				
	Ball joint clamp	28 - 32	336 - 384	38.1 - 43.5
	Ball joint nut	40 - 45	480 - 540	54.4 - 61.2
	Pitman nut (18-308-21 steering gear)	75 - 100	900 - 1200	102 - 136
	Pitman nut (18-308-25 steering gear)	181 - 217	2172 - 2604	246.2 - 295.1
	Rod end nut	20 - 25	240 - 300	27.2 - 34
	Steering shaft pinch bolt	24 - 26	288 - 312	32.6 - 35.4
	Steering wheel nut (18-308-21 steering gear)	28 - 32	336 - 384	38.1 - 43.5
	Steering wheel nut (18-308-25 steering gear)	72 - 86	864 - 1032	97.9 - 117
<i>Suspension</i> - - - - -				
	Leaf spring hangers	-	-	-
	<i>Note: Refer to maintenance section in the service manual</i>			



A small sample of the many types of vehicles offered by Taylor-Dunn®



B 2-48-36 Equipped with optional hydraulic dump bed

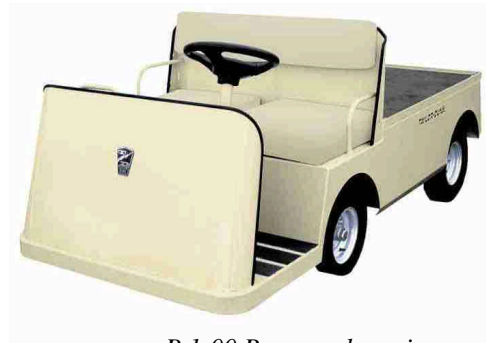

B 1-00 Personnel carrier



BT 2-80 Eight passenger tram



MX 1600 Equipped with optional ladder rack and weld tanks



C 4-25 Huskey tow tractor

Appendix C

BRAKE LINING HANDLING PRECAUTIONS

⚠ WARNING

Taylor-Dunn does not currently supply asbestos fiber-brake pads/shoes with any vehicle. However, there is the possibility that the original brake pads/shoes were replaced with aftermarket pads/shoes containing asbestos. Since this possibility does exist, the brake pads/shoes should be handled as if they do contain asbestos.

Never use compressed air or dry brush to clean the brake assemblies. Use an OSHA approved vacuum cleaner or any alternate method approved by OSHA to minimize the hazard caused by airborne asbestos fibers and brake dust.

Do not grind, sand, break, or chisel the brake pads/shoes, as this will cause unnecessary dust, possibly releasing asbestos fibers in the air.

Always wear protective clothing and a respirator when working on the brake pads/shoes or their associated components.

Inhaled asbestos fibers have been found to cause cancer and respiratory diseases.

Do not drive the vehicle if any worn or broken part is detected in any part of the brake system. The cause of the damage must be repaired immediately.

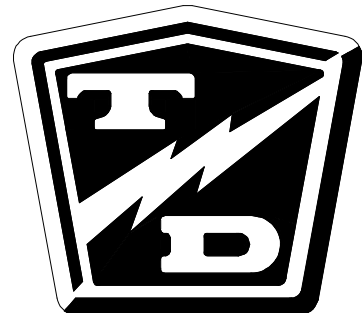



Model B 1-00

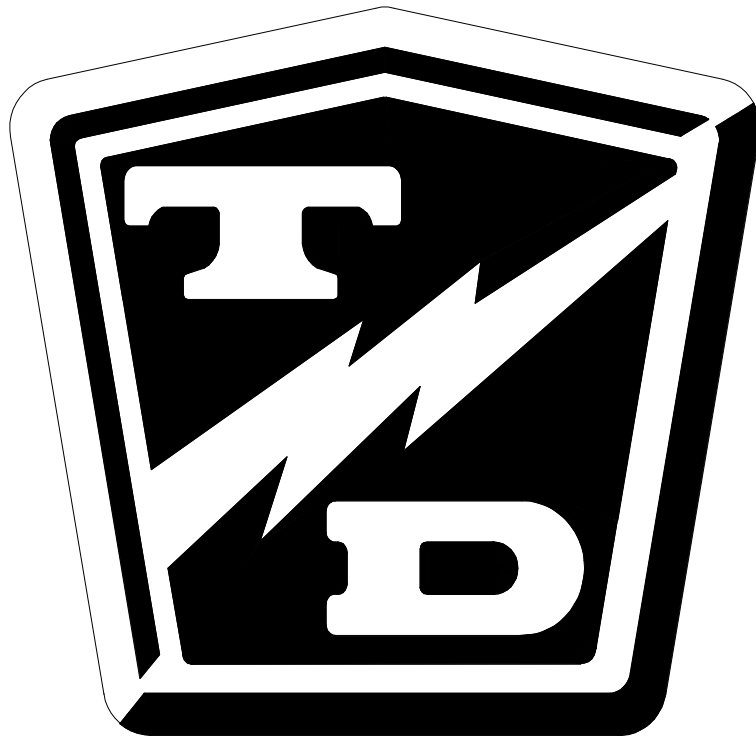

Taylor-Dunn® Mfg.
2114 W. Ball Rd.
Anaheim, CA 92804
(800)-688-8680
(714) 956-4040
(FAX) (714) 956-0504

Mailing Address:
P.O. Box 4240
Anaheim, California 92803

Visit our Website:
www.taylor-dunn.com