

**OPERATION
AND
MAINTENANCE
MANUAL
WITH
PARTS LIST**

MODEL:	B2-38,B2-48
SERIAL NO:	54833-74781
MANUAL NO:	MB-248-00

****IMPORTANT****

READ AND FOLLOW INSTRUCTIONS GIVEN IN SAFETY AND OPERATIONS SECTIONS, AND THOSE SECTIONS RELATED TO YOUR SERVICE AND REPAIR RESPONSIBILITIES.



TAYLOR-DUNN[®]
Commercial and Industrial Vehicles Since 1949

2114 W. Ball Rd., Anaheim, CA 92804 (714)956-4040 (FAX) (714)956-0504
Mailing Address: P.O. Box 4240, Anaheim, California 92803

- IMPORTANT INFORMATION -

This vehicle conforms to applicable portions of ANSI B56.8 {American National Standard Personnel and Burden Carriers}. This manual is designed for use by Vehicle Operators and Service Personnel alike. Throughout the manual, there are various WARNINGS, CAUTIONS, and NOTICES which must be carefully read to help reduce the possibility of personal injury. Maintenance personnel must understand that if a service procedure or method is used that is not recommended by Taylor-Dunn, it then becomes the personal responsibility of the person performing the work to first satisfy himself that neither his safety, the safety of others, or the safety of the vehicle will be endangered. ANSI B56.8 applies to only those vehicles with Serial Numbers dated after July 31, 1982.

Definitions of the three terms are as follows:

WARNING - There is a potential for injury to yourself or others.

CAUTION - There is a potential for damage to the vehicle.

NOTE - Specific information clarifying or giving the reason for a particular maintenance or service procedure.

Before operating your Taylor-Dunn vehicle, it is your responsibility to read, understand and follow the safety and operating instructions contained in this manual to help ensure your safety and comfort. If this car is to be used for rental purposes, it is your responsibility to explain to the operator about the various controls and vehicle operating characteristics. Equally important is the operators need to know the basic rules required for safe operation of the vehicle in day to day usage. Sections 5 and 6 of ANSI B56.8 have been inserted in Section B, page 3 of this manual for your specific operating guidelines.

1. Vehicle is to be operated only by qualified persons and only in designated areas.
2. Vehicle will not be started until all occupants are seated.
3. Occupants must remain seated while vehicle is in motion.
4. Arms, legs and feet must be kept inside while vehicle is in motion.
5. Slow down when making a turn.
6. Drive slowly straight up and down inclines.
7. Set parking brake before leaving vehicle.
8. Forward/Reverse lever must be in the correct position for direction of travel desired.

WARNING: *FAILURE TO COMPLY WITH ABOVE INSTRUCTIONS COULD RESULT IN INJURY TO THE VEHICLE OCCUPANTS, BYSTANDERS AND TO PROPERTY.*

TABLE OF CONTENTS

CONTENTS	SECTION	ILLUSTRATION
INSPECTION, SAFETY, AND INTRODUCTION	A	
OPERATING INSTRUCTIONS	B	
WARRANTY	C	
MAINTENANCE GUIDE CHECKLIST	D	
LUBRICATION DIAGRAM	E	FIGURE 1
TROUBLE SHOOTING CHECKLIST	F	
WIRING DIAGRAM	G	FIGURE 2
PARTS ORDERING PROCEDURE	H	
RECOMMENDED SPARE PARTS LIST	I	
MAINTENANCE PROCEDURES, SERVICE AND ADJUSTMENTS,		
PARTS ILLUSTRATIONS AND LISTINGS		
FRONT AXLE, STEERING, AND TIRES	J1	FIGURE 3 or 4
REAR AXLE, MOTOR, AND BRAKES	J2	FIGURE 5
D.C. MOTOR	J2M	FIGURE 5M
HYDRAULIC BRAKE SYSTEM	J3	FIGURE 6
MECHANICAL CONTROL LINKAGE	J4	FIGURE 7
FORWARD REVERSE SWITCH	J5	FIGURE 8
SPEED CONTROL AND MAIN POWER SWITCHING	J6	FIGURE 9
GENERAL ELECTRICAL SYSTEM	J7	FIGURE 10
BATTERIES AND CHARGER	J8	
BODY AND TRIM PARTS	J9	FIGURE 11
STEERING WORM ASSEMBLY, DISASSEMBLE/REASSEMBLE	J1A	FIGURE 4A

INSPECTION, SAFETY AND INTRODUCTION
ARRIVAL INSPECTION CHECKLIST

Visual Inspection should be made to determine that the truck has remained in good condition during transit. If any damage is found, the details should be noted on the delivery receipt immediately. After delivery the truck should be most carefully checked for HIDDEN DAMAGE. Any concealed damage not noted on the delivery receipt should be reported, in writing, to the delivering carrier within 48 hours.

The following checklist has been prepared to aid you during arrival and inspection of your vehicle.

- A. Open all packages and examine any accessories which may be shipped detached from vehicle.
- B. Examine wiring for visible evidence of damage. Check all connections to insure that none have loosened during transit.
- C. Check all battery connections and electrolyte level in each cell.
- D. Inspect battery charger in accordance with manufacturers installation instructions.
- E. Check tires for damage and proper inflation. Check wheel lugs to insure their being tight.
- F. If vehicle is equipped with hydraulic brakes, check hydraulic lines for evidence of damage.
- G. Check brake fluid level in master cylinder.
- H. Examine entire vehicle for damage such as dents or cracks.
- I. Check operation of controls to see that they are working freely.

Upon completion of the Visual Inspection, an operational test should be made after a thorough review of Section A, (Inspection, Safety & Introduction) and Section B, (Operating Instructions).

INSPECTION, SAFETY AND INTRODUCTION

SAFETY

The safe and satisfactory use of any vehicle is a responsibility shared by many persons.

As the manufacturer, we feel that it is our responsibility to emphasize vehicle characteristics and make safety recommendations regarding those characteristics. That is the primary purpose of this portion of the manual.

Persons who operate this vehicle need to be aware of, and to observe, the safe driving rules established in their locality, and need also to be aware of the vehicle operating characteristics and safety recommendations of the manufacturer, to assist them in exercising the judgement necessary to prevent injury to themselves or to others.

IMPORTANT:

Persons who service and maintain the vehicle need to be aware of how their activities relate to safe vehicle operation, and of potential hazards involved in the service and maintenance processes, to assist them is applying sensible judgement to those processes.

STEERING This vehicle has a very small minimum turning radius, and low ratio steering leverage.

CAUTION: These characteristics, so desirable for maneuverability at slow speeds, require that great care be exercised at high speeds to avoid turning so sharply that one or more wheels lose contact with the ground, or that the vehicle is caused to overturn. Be especially careful while traveling on an incline. Avoid sharp turns, even at slow speeds.

SPEED This vehicle is designed to attain its maximum safe operating speed on level ground. That speed can easily be exceeded when traveling down-hill. If this is allowed to occur, vehicle stability and braking performance become unpredictable. CAUTION: Do not exceed, under any circumstances, the maximum design speed of the vehicle.

CONTROLS Bring the vehicle to a complete standstill before operating the forward/reverse switch to change direction of travel. Operation of this control while the vehicle is in motion can result in complete loss of power. Do not use the accelerator to hold the vehicle at a standstill on an incline. This can cause complete power loss. Use only the brakes to hold the vehicle at rest while on a hill. CAUTION: Intentional/unintentional mis-use of controls could result in an accident.

BRAKES The brake system relies on contact of rear tires with the ground for effectiveness. As tire to ground contact is reduced, braking effect is reduced. While driving, the operator must consider terrain, speed, and steering maneuvers to prevent tires from losing contact with the ground, with consequent reduction of braking action.

INSPECTION, SAFETY AND INTRODUCTION

SAFETY

Maintenance Many operating characteristics relate to maintenance in ways which are not readily obvious. Those maintenance characteristics most closely related to vehicle operating safety are indicated on Section E, Page 1 and Section D, Page 1 and Page 2.

CAUTION:

Also to be considered is the safety of personnel who perform service and maintenance duties. Two characteristics need special emphasis.

1. This electric vehicle does not "idle" noisily, is never "out of gear", and is set into motion whenever the battery to the motor circuit is closed, intentionally or otherwise. Whenever practical disconnect battery leads to avoid unintentional starting of the motor during servicing or maintenance.
2. Batteries emit gasses which can be explosive, especially while they are being charged. Personnel who are involved with servicing vehicles, or maintaining vehicles, need to be made familiar with this hazard. A detailed explanation is contained on Pages 1 and 3 of Section J8.

CAUTION:

1. When performing maintenance on any part of the vehicle electrical system, disconnect main battery leads, place forward/reverse switch in neutral. Remove key from keylock in dash panel.
2. Never replace a circuit fuse with one having a higher rating than the original equipment fuse. Fuses have been selected to provide full circuit protection for all operating conditions. A FUSE WILL ONLY BLOW DUE TO A SHORT-CIRCUIT. Therefore, always locate and correct the cause of short-circuit before replacing a blown fuse. Using a fuse of higher rating is an UNSAFE PRACTICE and could cause serious damage to equipment.
3. Intentional or unintentional mis-use of controls could result in an accident.

INTRODUCTION

This vehicle is designed to be driven on smooth surfaces in and around industrial plants, nurseries, institutions, motels, mobile home parks and resorts. It is not designed to be driven on the public highways. It is not designed to go in excess of 15 M.P.H. on level surfaces or downhill. Speeds in excess of this may result in steering difficulty and possible loss of vehicle control. Vehicle is not designed to be towed in excess of 15 M.P.H.

MODEL NO.

The following Model Numbers are covered by this manual - 1238B, 1248B, 237BN, 247BN, Starting with Serial Number 54834.

SERIAL NO.

The Serial Number of your unit is stamped into the angle frame number, under the rear of the seat cushion, 4" from the left side. The model number and serial number are on a nameplate riveted to the dash panel steering support shelf forward of the steering column, or on the kick panel below the passenger seat. In ordering parts or referring to your unit, please use these numbers. Replacement parts can be purchased directly from your local authorized dealer.

OPERATING INSTRUCTIONS

The controls on your Taylor-Dunn vehicle have been designed and located for convenience of operation and efficient performance. Before driving your vehicle for the first time, familiarize yourself with each of the controls. Read the following instructions and with power OFF, operate each control.

STEERING

The steering wheel and steering system is similar to automotive types. Turn the steering wheel to the right (clockwise) for a right turn and left (counterclockwise) for a left turn.

KEY LOCK

Your vehicle is equipped with a keyed lock located on the corner of forward reverse switch. It is designed to lock the switch in the neutral position only. The key will remove from the lock in the locked position (neutral) only.

PARK BRAKE (HAND)

The hand parking brake is located in the right center of floor board. To engage hand brake, grasp top lever and pull towards rear, all the way, til hand lever stops. To release brake, push hand lever all the way forward.

SERVICE BRAKE (FOOT)

The brake pedal is designed and located for right foot operation. It is the pedal located to the left of accelerator pedal. It functions the same as the brake pedal in your automobile. Depressing the pedal applies the braking action. The greater the effort applied to the pedal with your foot, the greater the braking action to your vehicle. Removing your foot from the pedal allows immediate release of the braking action to your vehicle.

FORWARD/REVERSE SWITCH

The forward/reverse switch is located to the right of the drivers seat. It is operated by the red handle. To place in forward position pull the red handle to the left towards the driver. To place in reverse position push the red handle to the right, away from the driver.

CAUTION: The forward/reverse switch serves the same purpose as the transmission in your automobile. Treat it with the same respect and care. DO NOT SHIFT from forward to reverse or vice-versa while the vehicle is in motion. Shifting while in motion, especially near top speed, causes great strain to your entire vehicle and will eventually cause severe damage, complete loss of power and could cause an accident.

ACCELERATOR PEDAL

The accelerator pedal is located to the right of the brake pedal. It is designed for right foot operation similar to your automobile. Depressing the pedal turns the power on to the motor. It also controls the amount of power delivered to the motor in 5 steps. When driving your vehicle you will be able to feel the 5 steps of power, with full power when accelerator is fully depressed and minimum power when only partially depressed. You will have the same control of power in both directions of travel. Your forward/reverse switch determines the direction of travel and your accelerator pedal controls the speed.

HORN BUTTON

The horn button is located at the center of the steering wheel. Depressing button sounds horn. Releasing button will immediately silence horn.

LIGHT SWITCH

The light switch that controls headlamps and taillamps is located in the control console between the seats. It is labelled for on/off positions.

BATTERY CHARGER

Refer to SECTION J8 for proper instructions to operate your battery charger.

STANDARD OPTIONAL ACCESSORIES

WINDSHIELD WIPER

On vehicles equipped with electric windshield wipers the control switch is located in the control console between the seats. It is labelled for on/off position.

DIRECTION SIGNALS

On vehicles equipped with directional turn signals the control is located on the steering column. Move the control lever in the direction you will be turning your steering wheel to signal the direction you intend to turn your vehicle. Indicating lamps are located within the twin signal control for your convenience.

The directional turn signal also serves as an emergency flasher control by pulling the control lever outward away from steering column when in neutral position.

SPECIAL ACCESSORIES

Refer to the appropriate section of this manual for separate operating instructions pertaining to any special feature or accessory your vehicle may have.

SECTION 5

OPERATING RULES AND PRACTICES

501 OPERATOR QUALIFICATIONS

Only trained and authorized operators shall be permitted to operate a Personnel and Burden Carrier. Operators of Personnel and Burden Carriers shall be qualified as to visual, auditory, physical, and mental ability to safely operate the equipment according to Section 5 and all other applicable parts of this standard.

502 PERSONNEL AND BURDEN CARRIER OPERATORS' TRAINING

(a) The carrier owner, lessee, or employer of the carrier operator shall conduct an operators' training program for the carrier operators.

(b) Successful completion of the operators' training program shall be required by the owner, lessee, or employer of the carrier operator before operation of the Personnel and Burden Carrier by any operator.

(c) An effective operator's training program should center around user company's policies, operating conditions, and their Personnel and Burden Carrier. The program shall be presented complete to all new operators and not condensed for those claiming previous experience.

(d) Information on operator training is available from several sources, including carrier manufacturers.

(e) The carrier owner, lessee, or employer of the carrier operator should include in the operators' training program the following:

(1) Careful selection of the operators, considering physical qualifications, job attitude, and aptitude

(2) Emphasis on safety of stock, equipment operator, and other employees.

(3) General safety rules contained in this standard and the additional specific rules determined by the carrier owner, lessee, or employer of the carrier operator in accordance with this standard, and why they were formulated

(4) Introduction of equipment, control locations and functions, and explanation of how they

work when used properly and when used improperly; and ground and floor conditions, grade, and other conditions of the environment in which the Personnel and Burden Carrier is to be operated

(5) Operational performance tests and evaluations during, and at completion of, the program

(6) Rules of the employer and any applicable labor contract governing and dealing with discipline of employees for violation of employer's rules, and including safety rules

503 OPERATOR RESPONSIBILITY

Operators of Personnel and Burden Carriers shall abide by the following safety rules and practices in 504, 505, 506, and 507.

504 GENERAL

(a) Safeguard the pedestrians at all times. Do not drive carrier in a manner that would endanger anyone.

(b) Riding on the carrier by persons other than the operator is authorized only when personnel seat(s) are provided. Do not put any part of the body outside the outer perimeter of the carrier.

(c) When a Personnel or Burden Carrier is left unattended, stop carrier, place directional controls in neutral, apply the parking brake, stop the engine or turn off power, turn off the control or ignition circuit, remove the key if provided, and block the wheels if machine is on an incline.

(d) A Personnel and Burden Carrier is considered unattended when the operator is 25 ft (7.6 m) or more from the carrier which remains in his view, or whenever the operator leaves the carrier and it is not within his view. When the operator of a Personnel and Burden Carrier is dismounted and within 25 ft (7.6 m) of the carrier still in his view, he still must have controls neutralized, and brakes set to prevent movement.

(e) Maintain a safe distance from the edge of ramps and platforms.

(f) Use only approved Personnel and Burden Carriers in hazardous locations.

(g) Report all accidents involving personnel, building structures, and equipment.

AMERICAN NATIONAL STANDARD
PERSONNEL AND BURDEN CARRIERS

ANSI B56.3-1981

(h) Operators shall not add to, or modify, the Personnel and Burden Carrier.

(i) Fire aisles, access to stairways, and fire equipment shall be kept clear.

(j) Operators and personnel shall be warned of the hazards of long hair and loose clothing.

505 TRAVELING

(a) Observe all traffic regulations, including authorized plant speed limits. Under normal traffic conditions keep to the right. Maintain a safe distance, based on speed of travel, from the carrier or vehicle ahead; and keep the Personnel and Burden Carrier under control at all times.

(b) Yield the right of way to pedestrians, ambulances, fire trucks, or other carriers or vehicles in emergency situations.

(c) Do not pass another carrier or vehicle traveling in the same direction at intersections, blind spots, or at other dangerous locations.

(d) Keep a clear view of the path of travel, observe other traffic and personnel, and maintain a safe clearance.

(e) Slow down and sound the audible warning device at cross aisles and other locations where visibility is obstructed.

(f) Ascend or descend grades slowly.

(g) Use extra caution when operating on grades. Never turn on any grade, ramp, or incline; always travel straight up and down.

(h) Under all travel conditions the carrier shall be operated at a speed that will permit it to be brought to a stop in a safe manner.

(i) Make starts, stops, turns, or direction reversals in a smooth manner so as not to shift the load, overturn the carrier, or both.

(j) Do not indulge in stunt driving or horseplay.

(k) Slow down when approaching, or on, wet or slippery surfaces.

(l) Do not run carrier onto any elevator unless specifically authorized to do so. Approach elevators slowly, and then enter squarely after the elevator car is properly leveled. Once on the elevator, neu-

tralize the controls, shut off power, and set brakes. It is advisable that all other personnel leave the elevator before a carrier is allowed to enter or leave.

(m) Avoid running over loose objects on the roadway surface.

(n) Prior to negotiating turns, reduce speed to a safe level, turning hand steering wheel or tiller in a smooth, sweeping motion.

506 LOADING

(a) Handle only stable or safely arranged loads. When handling off-center loads which cannot be centered, operate with extra caution.

(b) Handle only loads within the capacity of the Personnel and Burden Carrier as specified on the nameplate.

(c) Handle loads exceeding the dimensions used to establish carrier capacity with extra caution. Stability and maneuverability may be adversely affected.

507 OPERATOR CARE OF MACHINE

(a) At the beginning of each shift during which the Personnel and Burden Carrier will be used, the operator shall check the carrier condition and inspect the tires, warning devices, lights, battery, controller, brakes, and steering mechanism. If the carrier is found to be in need of repair, or in any way unsafe, or contributes to an unsafe condition, the matter shall be reported immediately to the designated authority, and the carrier shall not be operated until it has been restored to safe operating condition.

(b) If during operation the carrier becomes unsafe in any way, the matter shall be reported immediately to the designated authority, and the carrier shall not be operated until it has been restored to safe operating condition.

(c) Do not make repairs or adjustments unless specifically authorized to do so.

(d) The engine shall be stopped and the operator shall leave the carrier while refueling.

(e) Spillage of oil or fuel shall be carefully and completely absorbed or evaporated and fuel tank cap replaced before starting engine.

(f) Do not operate a carrier with a leak in the fuel system or battery.

(g) Do not use open flames for checking electrolyte level in storage batteries or liquid level in fuel tanks.

SECTION 6

MAINTENANCE PRACTICES

601 INTRODUCTION

Personnel and Burden Carriers may become hazardous if maintenance is neglected. Therefore, maintenance facilities, trained personnel, and procedures shall be provided,

602 MAINTENANCE PROCEDURES

(a) Maintenance and inspection of all Personnel and Burden Carriers shall be performed in conformance with the manufacturer's recommendations and the following practices.

(b) A scheduled preventive maintenance, lubrication, and inspection system shall be followed.

(c) Only qualified and authorized personnel shall be permitted to maintain, repair, adjust, and inspect Personnel and Burden Carriers.

(d) Before leaving the Personnel and Burden Carrier, stop carrier, place directional controls in neutral, apply the parking brake, stop the engine or turn off power, turn off the control or ignition circuit, and block the wheels if carrier is on an incline.

(e) Before undertaking maintenance or repair on carrier, raise drive wheels free of floor or disconnect battery, and use chocks or other positive carrier positioning devices.

(f) Block chassis before working under it.

(g) Before disconnecting any part of the engine fuel system of a gasoline or diesel powered carrier with gravity feed fuel systems, be sure shutoff valve is closed, and run engine until fuel system is depleted and engine stops running.

(h) Before disconnecting any part of the engine fuel system of LP gas powered carriers, close the LP gas cylinder valve and run the engine until fuel in the system is depleted and the engine stops running.

(i) Carriers shall be kept in a clean condition to minimize fire hazards and facilitate detection of loose or defective parts.

(t) Modifications and additions which affect capacity and safe machine operation shall not be performed by the customer or user without manufacturer's prior

(j) Operation to check performance of the Personnel and Burden Carrier shall be conducted in an authorized area where safe clearance exists.

(j) Before starting to operate the carrier:

(1) Have operator in the operating position.

(2) Depress clutch (or brake pedal on automatic transmissions and electric carriers).

(3) Place directional controls in neutral.

(4) Start engine or switch electric carrier to "on" position.

(5) Check functioning of directional and speed controls, steering, warning devices, and brakes.

(k) Avoid fire hazards and have fire protection equipment present in the work area. Do not use an open flame to check level or leakage of fuel, electrolyte, or coolant. Do not use open pans of fuel or flammable cleaning fluids for cleaning parts.

(l) Properly ventilate work area.

(m) Handle LP gas cylinders with care. Physical damage, such as dents, scrapes, or gouges, may dangerously weaken the tank and make it unsafe for use.

(n) Brakes, steering mechanisms, control mechanisms, warning devices, lights, governors, guards, and safety devices shall be inspected regularly and maintained in a safe operating condition.

(o) Special Personnel and Burden Carriers or devices designed and approved for hazardous area operation shall be inspected to ensure that maintenance preserves the original approved safe operating features.

(p) Fuel systems shall be checked for leaks and condition of parts. Action shall be taken to prevent the use of the carrier until the leak has been corrected.

(q) The Personnel and Burden Carrier manufacturer's capacity, operation, and maintenance instruction plates, tags, or decals shall be maintained in legible condition.

(r) Batteries, motors, controllers, limit switches, protective devices, electrical conductors, and connections shall be inspected and maintained in conformance with good practice.

have been made, the user shall ensure that capacity, operation, warning, and maintenance instruction plates, tags, or decals are changed accordingly.

(u) Care shall be taken to assure that all replacement parts are interchangeable with the original parts and of a quality at least equal to that provided in the

VEHICLE OWNER AND OPERATOR'S GUIDELINES

OPERATING YOUR VEHICLE

To put your vehicle into operation, unlock forward/reverse switch by turning keyed lock counter clockwise. Select direction you wish to travel by moving handle of forward/reverse switch into position. Release parking brake, slowly depress accelerator pedal until vehicle is moving at the desired speed. Steer vehicle as required utilizing the foot brake and accelerator to control your speed as desired.

CAUTION: DO NOT "hold vehicle at a standstill on a hill or incline using accelerator only. Continued "stalled" condition as described will damage motor and electrical controls. Use either your foot brake or hand brake to hold the vehicle on a hill safely.

CAUTION: When you leave your vehicle, it is best to always place forward/reverse switch in neutral position. Set parking brake to prevent vehicle from rolling free, and lock and remove key.

Drive safely and enjoy your Taylor-Dunn vehicle.

MAINTENANCE GUIDE CHECKLIST

This checklist is provided for your convenience as a guide for servicing your vehicle. If followed you will enjoy a good running and trouble free unit. It has been set up for average normal use. More frequent service is recommended for extreme or heavy usage. If desired your Taylor-Dunn dealer will gladly perform these services for you as he has expert service men in the field for this purpose. Do not hesitate to call your Service Manager if any questions arise.

CAUTION: When performing maintenance on any part of the electrical system, disconnect main battery leads, place Forward/Reverse Switch in Neutral, turn key to off position and remove from switch. Set Parking Brake.

MAINTENANCE	REFER SECTION	EVERY WEEK	EVERY MONTH	EVERY 3 MONTHS	EVERY YEAR
Check and fill batteries. If necessary fill with distilled water only.	J8	X	X	X	X
* Apply lube to speed control sliding contact area with electrically non-conductive applicator. Use T-D Grease 94-421-00 or a quality hi-temp grease with a 500 min. drop point.	J6 & E (See Note)	X	X	X	X
NOTE: *Switch may require cleaning and lubrication more often than once a month depending on vehicle operating environment. See Sect. J6 for additional information.					
*Check Rheostat adjustment	J6	X	X	X	X
Check tire pressure	J1	X	X	X	X
Adjust Motor Mount & Chain (Refer to Chart Sect. J2)	J2		X	X	X
Lubricate all Zerk Fittings	E		X	X	X
Lubricate all moving parts without Zerk Fittings. Use all purpose engine oil.	E		X	X	X
Wash off batteries with water (Use soda if necessary)	J8		X	X	X
*Check all wire connections. Be sure they are all clean and tight.	J5, J6 J7		X	X	X
* Check service and adjust parking and manually operated brake.	J2		X	X	X
*Check hydraulic brake system for leaks also check brake fluid level in master cylinder.	J3		X	X	X
Check rear axle differential oil level (Refer to lubrication diagram)	J2 & E		X	X	X

CAUTION: Never bend the brake band anchor bolt. Any bending of the bolt may result in unexpected failure of the bolt and complete loss of Drive Line braking Action.

MAINTENANCE GUIDE CHECKLIST

Maintenance Service	Refer Section	Every Week	Every Month	Every 3 Months	Every Year
* Check and adjust hand and foot operated brake system	J2		X	X	X
Check drive axle oil level. (Refer to lubrication diagram).	J2&E		X	X	X
* Lubricate front wheel bearings (2 zerk fittings)	E			X	X
* Clean surface between power bars of the speed control switch	J6&E			X	X
Check motor brushes. Blow out carbon dust. (Replace if necessary).	J2			X	X
* Check brake lining for wear.	J2			X	X
Drain differential and refill with SAE 20 oil (refer to lubrication diagram)	J2&E				X
Repack front wheel bearings. (Use wheel bearing grease).	J1&E				X
Lubricate steering gear box with grease.	E				X
* Check and adjust front wheel bearings	J1			X	X

CAUTION: Never bend the brake band anchor bolt. Any bending of the bolt may result in unexpected failure of the bolt and complete loss of Drive Line braking Action.

* Items related to safety recommendations

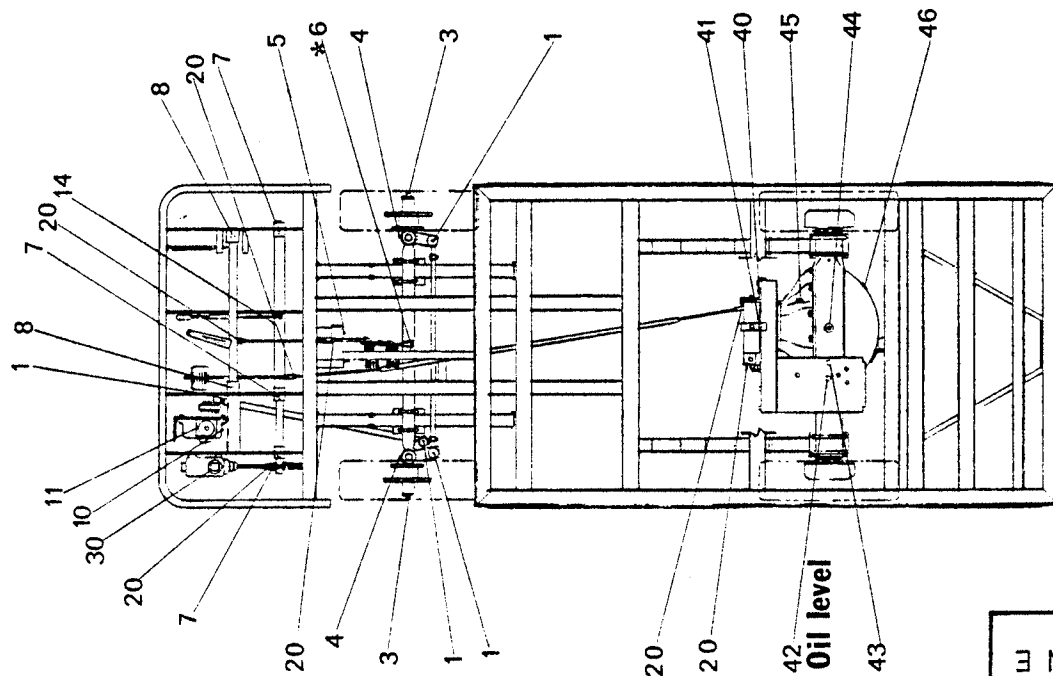

- 4 WHEEL MODEL -

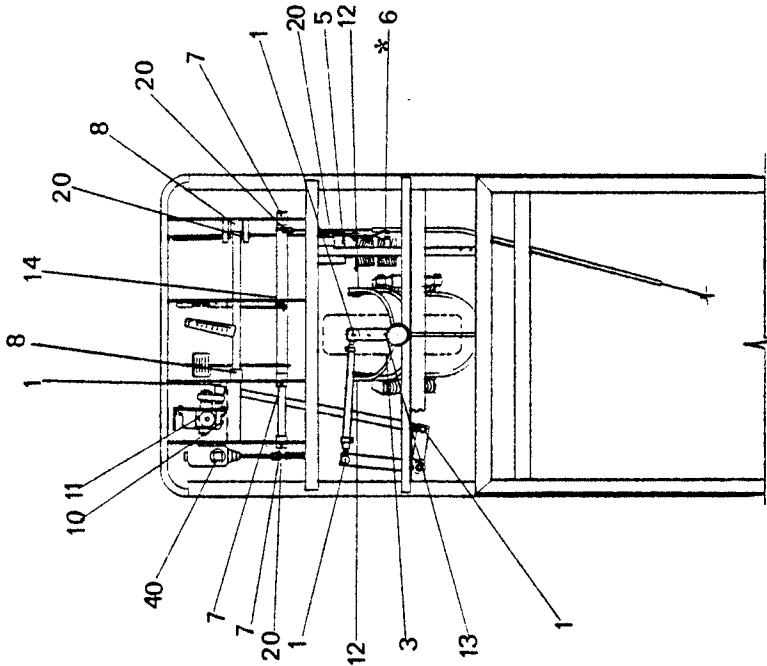

- 3 WHEEL MODEL -

NOTE:

*6. RHEOSTAT BARS - Lubricate Monthly. Apply lube to Speed Control Sliding contact area with electrically non-conductive applicator. Use T-D Grease 94-421-00 or a quality hi-temp grease with a 500° F Min. Drop Point.

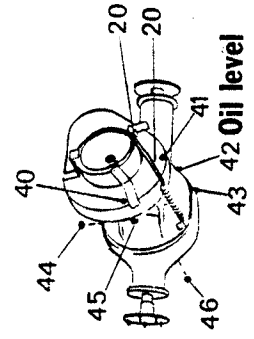

NO. OF GREASE POINTS
WHL. WHL.

PRESSURE GUN GREASE

- 1 Ball Joints 4 4
- 3 Front Wheel Hub 2 1
- 4 Front Wheel Spindle 2 0
- 5 Rocker Arm 1 1
- 6. (See Note #6)
- 7 Brake Linkage 3 3
- 8 Accelerator Linkage 2 2
- 10 Steering Worm 1 1
- 11 Grease Level Hole 1 1
- 12 Fork Pivot 0 2
- 13 Collar (Spindle) 0 1
- 14 Hyd. Brake Model only 1 1

LIGHT OIL

- 20 Clevis Pins-Mech. Linkage 6 6

BRAKE FLUID DOT #5 SILICONE

- 30 Master Cylinder (Option). 1 1

POWER TRACTION/SAE 30 Oil (2qts.)

- a. Remove Drain Plugs 41 & 42
- b. Remove Level Plugs 40 & 42 Fill Plug 44
- c. Drain Oil & Replace 41 & 43
- d. Add Oil By 44 To Level of 42
- e. Add Oil By 40 To ½" BELOW PLUG
- f. Replace Plugs

NOTE: 45 & 46 Not Used This Configuration

SECTION 1
PAGE 1

NO. DESCRIPTION	LENGTH	QUAN.	REVISED DATE	REVISION
TOL. FRAC. †	DEC. †			
SCALE				
DRAWN BY	J. M.			
DATE	12-8-81			
<p>FIGURE 1 SECTION E</p> <p>LUBRICATION DIAGRAM</p>				
<p>TAYLOR DUNN MFG. CO 2114 West Ball Rd. Anaheim, Calif.</p>				

TROUBLE SHOOTING PROCEDURES

<u>SYMPTOM</u>	<u>PROBABLE CAUSE</u>	<u>CORRECTIVE ACTION</u>
1. <u>Steering:</u>		
(a) Pull in one direction	1. Check for bent fork	Replace or straighten
(b) Hard Steering	1. Bad or frozen bearing in fork spindle collar 2. Low tire pressure	Replace Inflate to recommended pressure
(c) Sloppy or loose steering	1. Loose spindle bearing 2. Loose wheel bearing	Adjust Adjust
2. <u>Brakes:</u>		
(a) Soft brakes	1. Check for worn lining 2. Alignment of brake shoes 3. Oil on brake lining 4. Dirt on brake lining 5. Bind in linkage 6. Weak spring 7. Air in hydraulic brake lines 8. Bad seals in brake cylinders	Adjust or replace when 1/16 or less of lining left Realign Find oil source and correct, wash brake band Clean Loosen or realign Replace Bleed brakes Replace
(b) No Brakes	1. Broken shoe 2. Broken connection in linkage 3. Broken Axle 4. Break in hydraulic line 5. Seal failure in brake cylinder	Replace Replace Replace Repair Replace
3. <u>Drive Axle:</u>		
(a) No power	1. Discharged batteries 2. Check rheostat for contact 3. Check motor brushes for contact 4. Poor contact on forward-reverse switch 5. Check for loose wire 6. Check continuity through motor	Recharge or replace Adjust or replace bars Clean or replace Repair or replace Tighten or replace Repair or replace

<u>SYMPTOM</u>	<u>PROBABLE CAUSE</u>	<u>CORRECTIVE ACTION</u>
(c) Jerky Starting	<ol style="list-style-type: none">1. Resistor coil burned open2. Resistor shorted together3. Poorly adjusted rheostat4. Badly worn J-Hook5. Dirt between power bars causing shorts	<p>Replace Spread apart Re-adjust Replace J-Hook & bars</p>
(d) Takes off in forward or reverse without accelerator depressed	<ol style="list-style-type: none">1. Dirt shorting out neutral bar2. Check rheostat adjustment3. Short in wiring circuit4. Burned forward-reverse switch	<p>Clean, re-adjust or replace bars Correct Replace</p>
(e) Lack of Power or slow operation	<ol style="list-style-type: none">1. Dragging brake2. Tight front wheel bearing3. Rheostat not making contact on high speed bar4. Loose connection in wiring5. Partially burned out motor or thrown lead6. Weak batteries7. Bind or drag on differential	<p>Re-adjust Re-adjust Re-adjust or replace bars Tighten Replace or re-solder Replace Repair</p>
(f) Thump or grinding noise in drive axle	<ol style="list-style-type: none">1. Motor bearing2. Loose motor on base3. Worn Sprockets4. Defective bearing in differential5. Deffective gears in differential6. Slack Drive Chain	<p>Replace Tighten & adjust Replace sprocket and chain Replace Replace Adjust (Refer Section J2)</p>

PARTS ORDERING PROCEDURE

Parts may be purchased from your local authorized Taylor-Dunn Dealer. When ordering parts, be sure to specify the complete model number and serial number of this unit. Also specify the full Taylor-Dunn part number, description of part and quantity of parts required. You will find a complete listing of part numbers and descriptions in the following pages of this manual. When ordering parts for the drive motor, also include the specifications found on the motor name plate. Be sure to give complete shipping and billing address on all orders. Example:

- 1 - Part Number - 86-501-98 - Ball Joint (Left Hand Thread)
- 1 - Set of 4 - Part Number - 70-124-00 - Motor brushes for Baldor Motor, 3-1/2 H.P., 36 Volt, Specification No. 28-1408-11704

Above parts for model 1245B Truck, Serial Number 15039.

Parts ordered under warranty must be placed with your authorized Taylor-Dunn Dealer. Be sure to include original invoice number, date of shipment of vehicle, and vehicle serial number.

NOTE: On contracts with National Federal Government Agencies, Defence General Supply Agency, and United States Post Office Department, orders for all warranty parts must be placed directly with the Taylor-Dunn Factory in Anaheim, California.

TAYLOR-DUNN MANUFACTURING COMPANY
2114 West Ball Road
Anaheim, California 92804

Phone: 714-956-4040
Telex: 65-5393

SUGGESTED SPARE PARTS LISTS

T-D PART NO.	DESCRIPTION	QUANTITY OF 1-20 UNITS
11-040-00	Tube, 500 x 8	1
11-041-00	Tube, 950 x 8 or 850 x 8 (optional)	1
13-742-00	Tire, and Demountable Wheel, 500 x 8, 4 Ply, Suber Rib Tire with 5-1/2" Holes on 4-1/2" bolt circle	1
13-746-00	Tire, and Demountable Wheel, 800 x 8, 4 Ply, Terra Tire Power Rib, 5-1/2" Holes on 4-1/2" bolt circle	1
13-742-12	Tire, and Demountable Wheel, 5.70 x 8, 6 Ply	1
13-745-00	Tire, Tube and demountable Split Wheelrim with 500 x 8, 8 Ply Steelguard Tire, 5-1/2" Holes on 4-1/2" bolt circle	1
41-640-00	Brake Shoes (only with 7" Hydraulic Brakes)	2 Sets
41-661-61	Brake Band for Drive Shaft Brake, with Screw and Locknut	1
45-506-00	Oil Seal for G.E. Motor	1
-----	DC Electric Motor. See Section J2M for Part No. I.D. of motor supplied with vehicle.	1
-----	Motor Brushes. See Section J2M for Part No. I.D. of brushes supplied with vehicle.	4
71-100-00	Switch, light (single pole, single throw)	1
71-501-00	Horn Button	1
72-022-00	Light, stop & tail 4" rubber mount (12 volt)	1
72-072-00	Headlight, sealed beam bulb 4" (12 volt)	1
72-008-00	Headlight, sealed beam bulb 5-1/4" (12 volt) - Optional	1
73-000-00	Horn (12 volt)	1
75-231-00	Battery Jumper #6 wire, 10 1/2" Long	5
76-012-00	Charging receptacle 30 amp, 3 prong	3
77-200-00	Hydrometer	2
77-201-00	Battery Filler	1
78-010-00	Secondary Fuse and Holder, inline type	2
79-819-00	Fuse, 30 amp., Screw Type	10
79-823-00	Fuse, Buss Type, 20 amp	3
85-060-00	Spring, Compression 5/8" O.D. x 2-1/2" Long (Brake Band)	2
85-233-00	Spring extension, 11/16" O.D. x 6-1/4", accelerator return	4
85-270-00	Spring extension 1-1/4" O.D. x 4-3/8", brake return	4
85-250-00	Spring extension 1-1/16" O.D. x 3-5/8", brake pedal return	4
71-040-00	Switch, Forward/Reverse, 4 finger	1
71-040-60	Switch Finger - Silver Plated W/1/4" Hole	4
71-040-71	Bolt, Finger Mounting, 1/4 NF x 7/8"	4
71-040-62	Switch Handle, Metal, Red Color	1
71-040-54	Spring, Cam	1
71-040-52	Rotor Assembly	1

SUGGESTED SPARE PARTS LISTS

T-D PART NO.	DESCRIPTION	QUANTITY OF 1-20 UNITS
61-834-00	Insulating Board for J-Hook	1
61-832-00	Sliding J-Hook Bar	1
61-836-00	Pressure Bar	1
61-831-00	Power Bar	4
85-034-00	Spring, Compression 7/16" O.D. x 2" Long	1
78-212-51	Resistor coil #9 wire, 10 turns (used between 1st and 2nd speed)	1
78-212-52	Resistor coil #6 wire, 9 turns (used between 2nd and 3rd speed, all rheostats and 3rd and 4th speed on 5 speed rheostats)	2
78-212-53	Resistor coil #5 wire, 6 turns (used between last speeds on 4 and 5 bar rheostats)	1
78-302-00	Resistor, 10 OHM, 50 watt. Used with solenoid interlock option	2

MAINTENANCE PROCEDURES
FRONT AXLE, FORK, STEERING AND TIRES
REFER TO FIGURE 3

Your front wheel assembly consists of a ruggedly designed fork mounted with 2 Timken Roller Bearings. The front wheel is mounted on a 3/4" axle and turns on 2 Timken Roller Bearings. Two heavy coil springs and an automotive type shock absorber produce a comfortable ride. With proper care, these parts should give long service.

If by chance the front wheel should be submerged for any length of time in mud or water, it is recommended that you remove, wash & clean the axle assembly. Clean all parts, especially bearings, in a suitable cleaning solvent, re-assemble and repack with wheel bearing grease. Follow the procedures outlined in the service and adjustment section J1 of this manual.

The normal life of the shock absorber unit is 2 years, based on average use of vehicle.

The steering worm gear box and steering linkage is similar to those used on autos. It requires very little attention. Refer to Section J1A for disassemble and reassemble procedures Steering Worm Assembly. Refer to maintenance guide and lubrication diagrams (Section D & E) for normal care of your front wheel & steering assembly.

If service and adjustments are required, refer to appropriate section of this manual.

Tire Care:

Tire pressure is governed by how you want your vehicle to ride and the terrain to which it is most commonly used upon.

Slightly lower pressure will assist traction on soft terrain without undue wear.

The chart listed below will assist you to determine the correct tire pressure for your needs.

TIRE INFLATION CHART							
TIRE SIZE	TYPE	TIRE LOAD RATING		MAXIMUM (COLD) INFLATION P.S.I	5MPH MAXIMUM LOAD POUNDS	10MPH	15MPH
		LOAD RANGE	EQUIVALENT RATING				
4.90-8/400-8	HIGHWAY TREAD	A	2	35	640	505	470
4.80-8/400-8	HIGHWAY TREAD	B	4	70	960	760	710
4.80-8/400-8	STEELGUARD	C	6	100	1220	960	895
5.70-8/500-8	HIGHWAY TREAD	B	4	60	1240	980	915
5.70-8/500-8	HIGHWAY TREAD	C	6	90	1520	1240	1160
5.70-8/500-8	STEELGUARD	D	8	120	1860	1470	1370
16 X 6.50 X 8	TERRA TIRE	B	4	28		620	
18 X 8.50 X 8	TERRA TIRE	B	4	22		815	
18 X 9.50 X 8	TERRA TIRE	B	4	24		1040	

THE INFLATION AND LOAD RATINGS MOLDED ON HIGHWAY TREAD TIRES, PER FEDERAL STANDARD FMVSS-119, ARE FOR MAXIMUM HIGHWAY SPEEDS AND DO NOT APPLY TO THIS LOW SPEED VEHICLE.

- TAYLOR-DUNN MANUFACTURING CO. -

CAUTION: Do not over-inflate tires as this will promote increased wear. Under inflation especially on hard surfaces also promotes undue wear and should be avoided.

SERVICE AND ADJUSTMENT
REFER TO FIGURE 3
FRONT AXLE, FORK, STEERING AND TIRES (3 WHEEL MODEL)

Removal of tire wheel and axle assembly:

1. Remove 1 axle nut by holding nut on one end of axle and unscrewing nut on opposite end.
2. Slide axle from fork & wheel, being careful to catch spacers and wheel as they come free.
3. Tire may be changed or repaired without removing wheel from hub. To change wheel remove 5 lug nuts thereby releasing wheel from hub assy.
4. Wheel bearings may be flushed, cleaned and repacked without removing from hub, unless, severely damaged or embedded with foreign material.
5. To remove wheel bearings and seals:
 - A. Pull seals from hub.
 - B. Remove taper roller bearings.
 - C. If necessary, press bearing races from hub with suitable press or with flat punch by hitting back and forth one side to other.

Re-assembly and adjustments:

1. Press bearing races into hub with suitable press, taking care that they are seated against stops within the hub.
2. Generously lubricate wheel bearings with wheel bearing grease and insert into bearing races.
3. Press or tap seals into place. (proper position, is when face of seal is flush with end of hub) Note: It is recommended that new seals be installed whenever bearings are removed from wheel hub, or whenever seals are worn or damaged. Worn or damaged seals allow dirt and foreign matter to enter wheel bearings, shortening bearing life.
4. Install wheel & hub assembly into fork by starting axle through one side of fork, inserting 1 spacer then sliding axle through wheel bearings. Insert other spacer and slide axle through remainder of fork assembly.
5. Install locknut.
6. Adjust wheel bearings by holding 1 axle nut and tightening the other until a drag is felt on wheel. Then back off nut approximately 1/4 turn. Wheel should turn free but not have excess play in bearings.
7. Wheel hub has 1 zerk fitting for grease lubrication.

Dis-assembly of fork spindle:

1. Remove front seat cushions.
2. Remove 2 screws holding center control console.
3. Slide console far enough over to expose fork spindle.
4. Remove dust cap.
5. Remove cotter pin & nut on ball joint.
6. Rap ball joint stud sharply with soft hammer or use soft block and regular hammer to loosen tapered stud from steering arm.
7. Remove lock nut on spindle end.
8. Slide fork and spindle out of housing.
9. Remove bearings and dust seals.
10. A puller is required to remove bearing races from housing.

Re-assembly and Adjustments:

1. Bearing races may be pressed into position by using a $\frac{1}{2}$ " x 6" bolt. Place a disc or bar of suitable size over bolt then 1 bearing race, pass this assembly through housing. Place other bearing race, a suitable disc or bar and then the nut. Tightening the nut and bolt will draw the 2 bearing races into position without damage.
2. Generously pack bearings with wheel bearing grease. Assemble 1 dust seal and bearing on spindle in reverse order of removal. Refer to figure 3 for proper location. Slide fork spindle through housing and insert upper bearing and washer.
3. Install spindle nut.
4. Adjust by tightening nut until drag is felt on spindle bearings. Loosen about $\frac{1}{4}$ turn or until spindle rotates free but does not have any play in bearings.
NOTE: Any excessive play in spindle bearings can lead to bearing failure due to shock effect when vehicle encounters bumps or uneven terrain.
5. Replace ball joint and nut. Tighten securely and replace cotter pin.
6. Replace dust cap on fork spindle.
7. Replace control console
8. Replace seat cushions.
NOTE: There is 1 zerk fitting located on the fork spindle bearing housing which requires lubrication every 3 months. Refer to Lubrication Diagram and Maintenance Guide Section D & E

SERVICE AND ADJUSTMENT

REFER TO FIGURE 3

STEERING WORM GEAR BOX AND STEERING LINKAGE (3WHEEL MODEL)

Replace ball joint:

1. Remove cotter pin and nut.
2. Loosen sleeve clamp.
3. Rap ball joint stud sharply with soft hammer or soft block and regular hammer to loosen tapered stud from steering arm.
4. Either measure position of ball joint or count number of threads exposed from sleeve. Remove ball joint by unscrewing from sleeve. Note that 1 end will be left hand thread and the opposite ball joint will be right hand thread
5. Install new ball joint and position same as the one removed.
6. Install tapered stud in steering arm.
7. Replace nut, tighten securely and replace cotter pin.

8. Check travel of steering linkage to be sure it has not been affected by the new ball joint not being correctly positioned. Steering wheel should be in central position when wheel is in straight ahead position. Correct any misalignment by loosening both clamps and turning sleeve.
9. Tighten sleeve clamps securely.
10. Lubricate zerk fitting on new ball joint with appropriate grease. Refer to Lube Chart.

Replacement of steering worm:

1. Pry steering wheel cap up to expose locknuts holding horn button in place.
2. Remove 2 horn button screws.
3. Remove wiring from horn button and slide out of steering tube through bottom.
4. Remove lock nut and with suitable puller remove steering wheel.
5. Remove steering support cover.
6. Mark position of steering arm and remove from worm shaft.
7. Remove lock nut holding steering lever on shaft.
8. Remove 3 steering worm holding bolts and slide steering worm assembly from bottom of vehicle.
9. If installing new steering worm it is important to place the steering lever in the same relative position on the new unit as it was on the old unit. Failure to do this will result in a misalignment of the Transfer linkage and a limitation of steering in one direction.
10. Install steering worm in the reverse manner to which it was removed, outlined in steps 1 to 8.
11. When installing steering wheel, rotate the steering shaft until the front wheels are in a straight ahead position. Then place the steering wheel on the shaft aligning it in a central position.
12. Adjust any minor misalignment by loosening the steering link sleeve clamps and adjusting the steering link until the front wheel & steering wheel are both in position.
13. Check that you will be able to return the steering mechanism equally in both directions. If you cannot, it means the universal yoke was not properly installed and it will be necessary to separate universal, remove yoke and replace it in the proper position.
14. Lubricate steering worm through zerk fitting located on worm housing. Refer to Lubrication Diagram and Maintenance Guide Sections D & E.

DISASSEMBLE AND REASSEMBLE STEERING WORM (SEE SECTION J1A)



TAYLOR DUNN MFG. CO.
2114 West Ball Rd.
Anaheim, Calif.

LENGTH | QUAN | REVISED DATE | REVISION

FRONT FORK & STEERING
3 WHEEL MODEL

FIGURE 3
SECTION J1

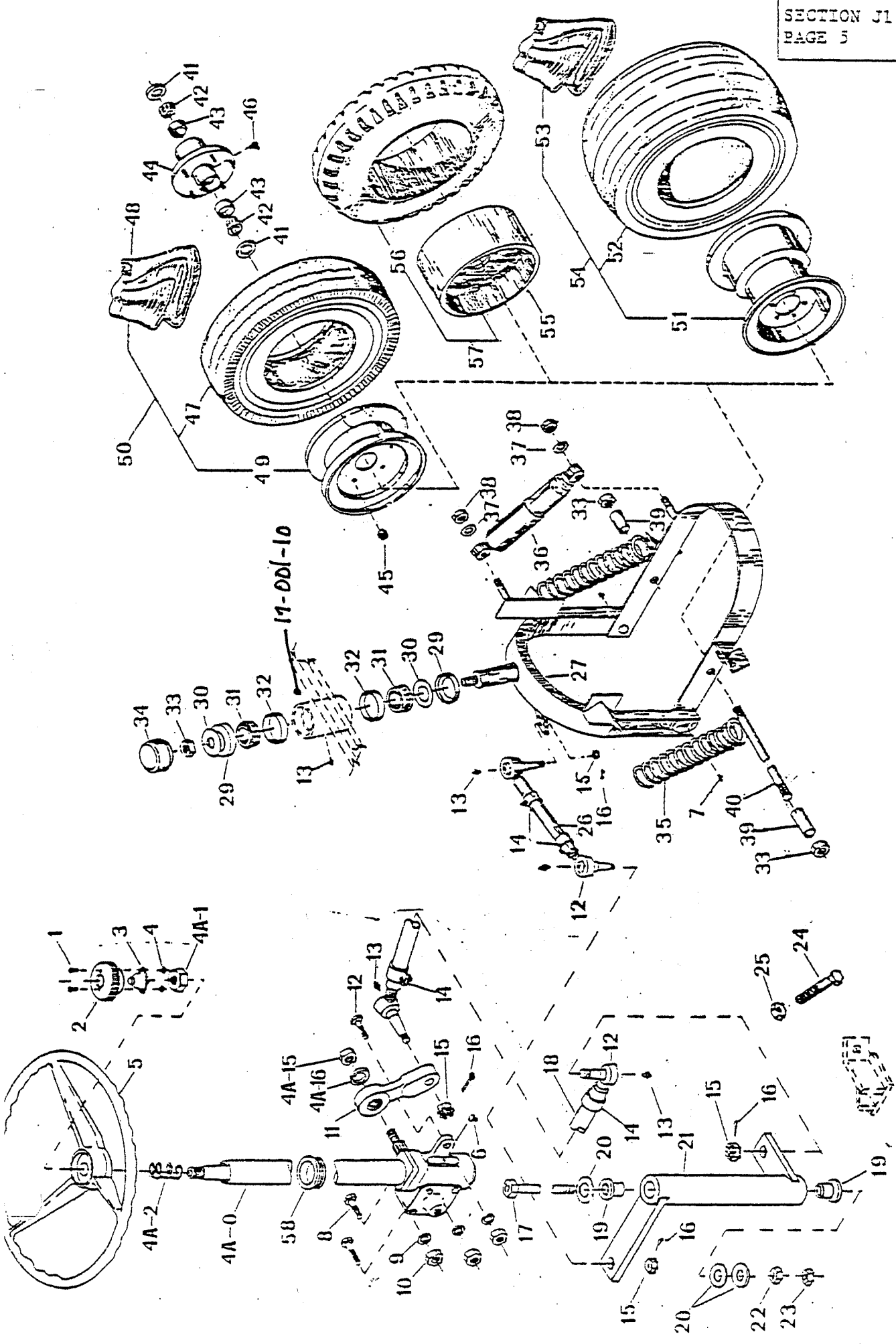

NO. | DESCRIPTION

FOR FRAC. | DEC. |

SCALE NONE

DRAWN BY REA

DATE 1-1-79

3 WHEEL FRONT AXLE AND STEERING
REFER TO FIGURE 3

FIG. I.D. NO.	T-D PART NO.	DESCRIPTION	QTY. REQ.
3-1	88-025-08	8-32 x 5/8" Truss Head Machine Screw	2
3-2	19-004-20	Cap - With Horn Button Hole (Steering Wheel)	1
3-3	71-501-00	Horn Button (Standard)	1
3-4	88-029-80	Lock Nut 8-32 (Hex)	2
3-5	19-003-10	Steering Wheel	1
3-6	87-073-00	Grease Fitting - 3/16 Drive, 45 Degree	1
3-7	87-071-00	Grease Fitting (3/16" Drive Type - Straight)	2
3-8	88-130-14	7/16 - 20 x 1 1/2 NF Hex Head Cap Screw	3
3-9	88-128-60	Washer 7/16" Flat	3
3-10	88-130-86	7/16 NF Hex Locknut	3
3-11	18-104-00	Steering Lever	1
3-12	86-501-98	Ball Joint (Left Hand Thread)	2
3-12	86-501-99	Ball Joint (Right Hand Thread)	2
3-13	87-074-00	Grease Fitting 1/4"-28 Thd. (Straight)	3
3-14	86-510-00	Ball Joint Clamp	4
3-15	88-159-85	Castle Nut 1/2" NF (Hex)	4
3-16	88-527-11	Cotter Pin 1/8" x 1"	4
3-17	50-034-00	Idler Arm	1
3-18	18-055-10	Sleeve Assembly Steering Adjustment with Ball Joints & Clamps - (27" with Bend)	1
3-18	18-055-11	Sleeve, Steering Adjustment, 27" with Bend	1
3-19	32-215-00	Bushing, Plastic 1/2" ID x 11/16" OD	2
3-20	88-148-61	1/2" SAE Washer	3
3-21	18-084-50	Idler Arm Weldment	1
3-22	88-149-80	1/2" NC Hex Head Nut	1
3-23	88-149-81	1/2" NC Locknut	1
3-24	88-151-16	1/2" x 2" NF Hardened Hex Head Cap Screw	1
3-25	88-159-82	1/2" NF Jam Nut	1
3-26	18-020-00	Steering Adjustment Sleeve (4-1/2" Long)	1
3-26	18-020-10	Steering Adjustment Sleeve Assembly, with Ball Joints and Clamps (4-1/2" Long)	1
3-27	14-024-10	Front Form Assembly (Less Springs)	1
3-29	45-307-00	Dust Seal	2
3-30	88-228-60	Washer - 3/4" Flat	1
3-31	80-011-00	1 1/2" Tapered Roller Bearing	2
3-32	80-102-00	Tapered Bearing Race for 1 1/2" Bearing	2
3-33	88-229-81	Lock Nut - 3/4" N.C. (Hex)	1

FIG. I.D. NO.	T-D PART NO.	DESCRIPTION	QTY. REQ.
3-34	92-105-00	Dust Cap for 1½" Bearing	1
3-35	85-150-00	Spring Compression 2½" OD x 9-3/8"	2
3-36	86-000-00	Shock Absorber	1
3-37	88-188-60	Washer 5/8" Flat	2
3-38	88-189-81	Lock Nut 5/8" NC(Hex)	2
3-39	16-043-00	Wheel Spacer 3/4" I.D. x 3-1/8" Long	2
3-40	15-030-00	Front Axle 3/4" Dia. x 13" Long	1
3-41	45-308-00	Oil Seal (Front Wheel)	2
3-42	80-015-00	Tapered Roller Bearing 3/4" I.D.	2
3-43	80-105-00	Tapered Bearing Race For 3/4" I.D. Bearing	2
3-44	12-120-00	Wheel Hub	1
3-45	97-236-00	Lug Nut -½" Tapered	5
3-46	87-050-00	Grease Fitting ¼ - 28 Thread (90°)	1
3-47	10-081-00	Tubeless Tire - 570 x 8 - 4 Ply - Super Rib	1
3-47	10-082-00	Tire - x 8 - 4 Ply, Extra Grip, Tube Type	1
3-47	10-088-00	Tire - 570 x 8 - 8 Ply Steel Guard	1
3-48	11-040-00	Tube - 570 x 8 (Can be Used with Tubeless Tire)	1
3-49	12-012-00	Wheel for 570 x 8 Tire (Five ½ In. Holes on 4½" Bolt Circle)	1
3-49	12-042-00	Wheel, Split Disc, for 570 x 8 Steelguard Tire (Five ½ In. Holes on 4½ In. Bolt Circle)	1
3-50	13-742-00	Tire and Demountable Wheel - 570 x 8, 4 Ply, Super Rib Tire, Five ½ In. Holes on 4½ In. Bolt Circle	1
3-50	13-744-00	Tire, Tube and Demountable Wheel - 570 x 8, 4 Ply, Extra Grip Tire (Five ½ In. Holes on 4½ In. Bolt Circle on Wheel)	1
3-50	13-745-00	Tire, Tube and Demountable Wheel - 570 x 8, 8 Ply, Steelguard Tire (Five ½ In. Holes on 4½ In. Bolt Circle on Wheel)	1
3-51	12-020-00	Wheel for 850 x 8 or 950 x 8 Tire (Five ½ In. Holes on 4½ In. Bolt Circle)	1
3-52	10-093-00	Tire, 850 x 8, 4 Ply, Terra Tire, Power Rib Tubeless	1
3-52	10-092-00	Tire - 950 x 8, 6 Ply Terra Tire, Traction Tubeless	1
3-53	11-041-00	Tube for 850 x 8 or 950 x 8 Tire	1
3-54	13-746-00	Tire and Demountable Wheel, 850 x 8, 4 Ply, Terra Tire, Power Rib (Five ½ In. Holes on 4½ In. Bolt Circle)	1
3-55	12-050-00	Wheel, Cast Iron for 18 x 5 5 12-1/8 Solid Cushion Tire (Five ½ In. Holes on 4½ In. Bolt Circle)	1

FIG. I.D. NO.	T-D PART NO.	DESCRIPTION	QTY. REQ.
3-56	10-260-00	Tire - Solid Extra Cushion, All Service 18 x 5 x 12-1/8	1
3-57	13-955-10	Tire and Demountable Cast Iron Wheel - 18 x 5 x 12-1/8 Solid Extra Cushion, All Service Tire (Five 1/2 In. Holes on 4 1/2 In. Bolt Circle on Wheel)	1
3-58	98-602-00	Grommet, Rubber, 1 1/2" I.D.	1

MAINTENANCE PROCEDURES

REFER TO FIGURE 4

FRONT AXLE, STEERING AND TIRES (4 WHEEL MODEL)

Your front axle and wheel assembly consists of an axle mounted on 2 leaf springs with automotive spindles, steering worm, and steering linkage. It has been designed for rugged dependable service with little maintenance requirements, other than lubrication and an occasional check of all nuts and bolts for tightness. Your wheels revolve on Timken Roller Bearings and the spindles are mounted with heavy kingpins.

Zerk type grease fittings have been provided to insure proper amounts of lubricant reaching wear points.

It is recommended that you follow the maintenance guide and lubrication diagrams for normal maintenance of the assembly. They are located in Sections D and E of this manual.

The maintenance guide is set up for average use. If the vehicle is subject to long hours of running and heavy work loads the frequency of lubrication and service should be increased accordingly.

Refer to the service and adjustment Section J1 of this manual for guidance when performing major repairs and adjustments.

If your vehicle is equipped with 4 wheel hydraulic brakes, refer to the service and adjustment Section of this manual under Hydraulic Brake Section J3 for their proper care and adjustments.

The steering worm gear box and steering linkage is similar to those used on autos. It requires very little attention. Refer to Section J1A for disassemble and reassemble Steering Worm Assembly.

Refer to maintenance guide and lubrication diagrams (Sections D & E) for normal care.

If service and adjustments are required, refer to appropriate section of this manual.

Tire Care:

Refer to Section J1, 3-wheel model.

SERVICE AND ADJUSTMENT
REFER TO FIGURE 4
FRONT AXLE, STEERING AND TIRES (4 WHEEL MODEL)

REMOVE AND INSTALL WHEEL HUB: ADJUST BEARINGS

1. Remove wheel cover.
2. Remove dust cap.
3. Remove cotter pin and unscrew spindle nut.
4. Remove outer washer and bearing.
5. Remove wheel, tire, and hub assembly.
6. Before re-assembly, thoroughly clean the bearings, spindle, and hub assembly. Inspect bearings for wear or damage. Examine inner seal. Replace damaged or worn parts.
7. Generously pack bearings with wheel bearing grease.
8. Reassemble in reverse order. Adjust wheel bearings before installing cotter pin.
9. Adjust wheel bearings by tightening spindle nut until bearing drag barely occurs, then back off spindle nut approximately 1/4 turn. Wheel should turn freely without noticeable bearing end play.
10. Install cotter pin, dust cap and wheel cover.
11. Wheel hub has one zerk fitting for periodic lubrication of bearing without disassembling hub. Refer to Lube Chart in Section E.

REMOVE AND INSTALL KING PINS AND BUSHINGS

1. Remove wheel and hub from spindle. See preceding subsection.
2. Remove ball joints from steering arms. Remove cotter pin and nut, rap stud sharply with soft hammer, or soft block and regular hammer, to loosen tapered stud from steering arm.
- 2a. Disconnect drag link ball joint at Pitman Arm, remove cotter pin and nut, rap stud sharply with soft hammer, or soft block and regular hammer, to loosen tapered stud from Pitman Arm.
3. Remove 7/8 lock nut which retains spindle and steering arm assembly to kingpin.
4. Remove kingpin from axle. If it is necessary to force the pin from the axle, use a soft rod, such as bronze or aluminum.
5. Remove spindle and steering arm assembly, and thrust bearing, from axle yoke.
6. Press bushings from spindle.
7. Thoroughly clean bushing housing and kingpin before installing new bushings.
8. Press bushing into sleeve. It may be necessary to ream the bushings after they are installed in the sleeve because of slight distortion which may occur during the process of pressing them into place. If proper press and reamer are not available, most automotive supply houses and repair shops have capacity to perform this service.
9. Reassemble in reverse order. Lightly oil kingpin and tap into place in axle. Where it is necessary to use force to assemble components, use a soft hammer or punch.
10. After reassembly, tighten ball joints securely. Lubricate bushings and kingpin through grease fitting. Adjust wheel bearings as described in preceding subsection. Align front end as described in subsection titled "Align Front End: Adjust Toe-In".

SERVICE AND ADJUSTMENT
REFER TO FIGURE 4
FRONT AXLE, STEERING AND TIRES (4 WHEEL MODEL)

ALIGN FRONT END: ADJUST TOE IN

1. Caster and camber are set at the factory and do not require adjustment. To adjust toe-in, raise front end of vehicle off the ground.
2. With a pencil, make a mark around center of tread of tire by holding pencil point against tire while turning wheel. Mark both front tires.
3. Lower vehicle to ground. Loosen tie-rod sleeve clamps at each end of tie-rod so that adjusting sleeve can be turned.
4. With wheels in straight forward direction, measure the distance between pencil lines at the front of the tires, and as the rear of the tires.
5. Adjust the tie-rod sleeve until the distance from mark to mark across the front of the tires is the same as the distance from mark to mark across the rear of the tires.
6. Tighten the adjusting sleeve clamp nuts securely, taking care to avoid changing the position of the adjusting sleeve.

REMOVE AND REPLACE BALL JOINT

1. Remove cotter pin and nut.
2. Loosen sleeve clamp.
3. Rap ball joint stud sharply with soft hammer or soft block and regular hammer to loosen tapered stud from steering arm.
4. Either measure position of ball joint or count number of threads exposed from sleeve. Remove ball joint by unscrewing from sleeve. Note that one end will be left hand thread and the opposite ball joint will be right hand thread.
5. Install new ball joint and position same as the one removed.
6. Install tapered stud in steering arm or Pitman Arm.
7. Replace nut, tighten securely and replace cotter pin.
8. If ball joint replaced is part of the tie-rod, check toe-in and adjust if necessary - as described in subsection titled "Align Front End".
9. If ball joint replaced is part of the linkage from Pitman arm to steering arm, check relative positions of steering wheel and road wheels. Steering wheel spoke should be in the six o'clock position when the road wheels are in the straight forward position. Adjust by rotating the adjusting sleeve until the desired relationship is obtained.
10. Tighten both sleeve clamps securely.
11. Lubricate ball joint through zerk fittings. Refer to Lube Chart in Section E.

REMOVE AND REPLACE STEERING WORM ASSEMBLY

1. Pry steering wheel cap up to expose locknuts holding horn button in place.
2. Remove 2 horn button screws.
3. Remove wiring from horn button and slide out of steering tube through bottom.
4. Remove lock nut and with suitable puller, remove steering wheel.
5. Align steering lever & drag link grease fitting up with the hole in support plate under floor board.
6. Remove Cotter Pin & Castle Nut on drag link. Remove drag link.
7. Remove 7/8 Nut & lock washer on steering lever & steering worm assy. remove steering lever.
8. Remove 10 #8 x 1/2 Hex Hd. sheet metal screws from steering gear support cover & remove cover from steering gear support.
9. Remove 3 7/16-20 UNF Hex Hd. cap screws & nuts from steering worm assy. and steering gear support.
10. Pulling to the right & turning steering worm assy. clockwise pull steering worm assy. down & out of car.
11. Install steering worm in reverse to manner outlined in steps 1 to 8.
12. When installing steering wheel, rotate the steering shaft until the front wheels are aimed straight ahead. Install steering wheel in centered position.
13. Adjust minor misalignment. Loosen steering link sleeve clamps and adjust steering link until front wheel and steering wheel are both in position.
14. Check that you will be able to turn the steering mechanism equally in both directions. If you cannot, it means the steering arm was not properly installed and it will be necessary to remove the arm and replace it in the proper position.
15. Lubricate steering worm through zerk fitting located on worm housing. Refer to Lubrication Diagram and Maintenance Guide Sections D & E.

DISASSEMBLE AND REASSEMBLE STEERING WORM

REFER TO SECTION J1A

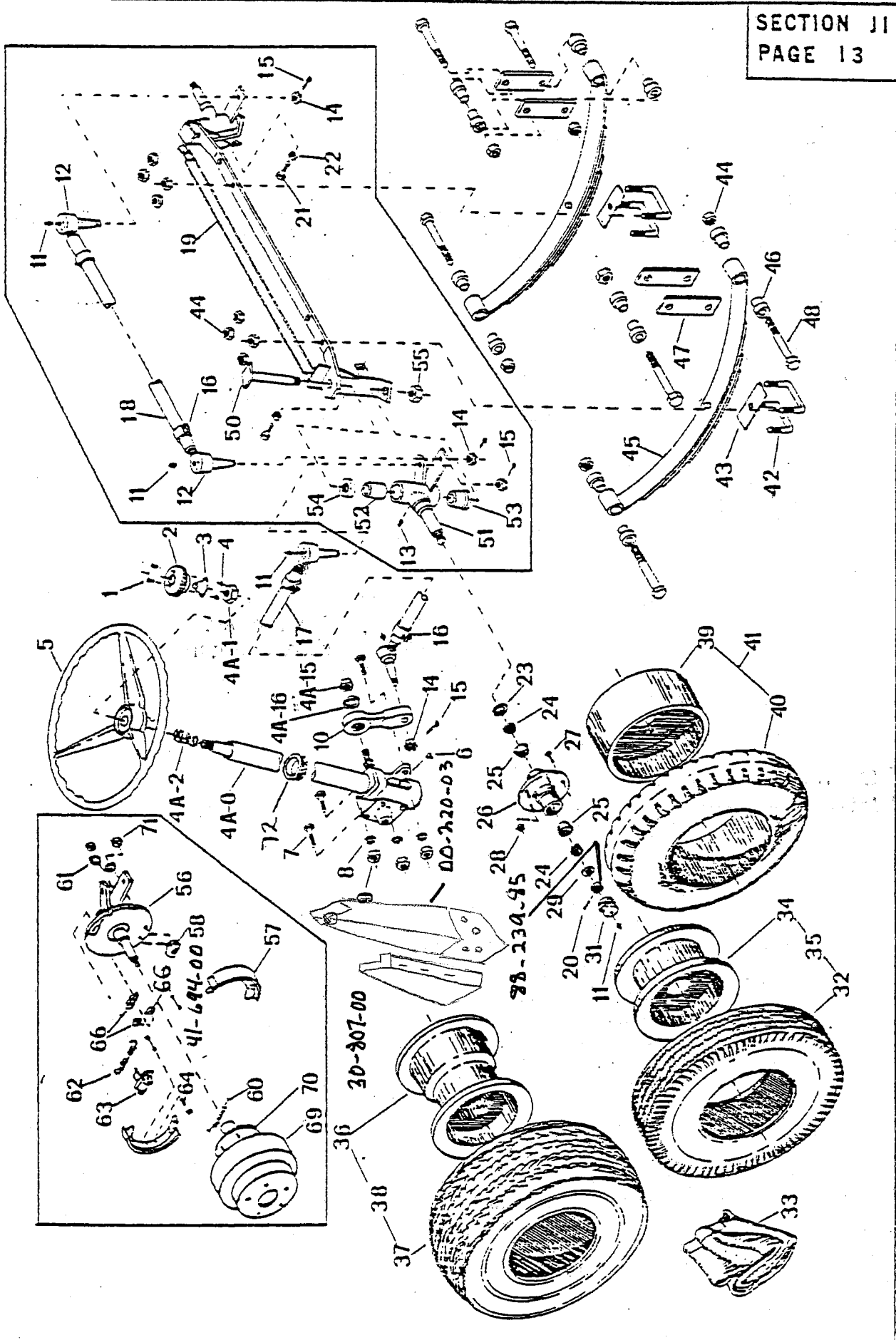

LENGTH | QUAN | REVISED DATE | REVISION

FRONT AXLE & STEERING
MODEL B - 4 WHEEL

FIGURE 4
SECTION J1

NO.	DESCRIPTION
TOL. FRAC.	DEC.
SCALE	
DRAWN BY	J.M.
DATE	7-7-80

4 WHEEL FRONT AXLE AND STEERING
REFER TO FIGURE 4

FIG. I.D. NO.	T.D.PART NO.	DESCRIPTION	QTY. REQ.
4-1	88-025-08	Truss Head Machine Screw 8-32 x 5/8"	2
4-2	19-004-20	Cap with Horn Button Hole (Steering Wheel)	1
4-3	71-501-00	Horn Button (Standard)	1
4-4	88-029-80	Lock Nut 8-32 (Hex)	2
4-5	19-003-10	Steering Wheel	1
4A-0, 4A-1, 4A-2, 4A-15, 4A-16		NOTE: REFER TO SECTION J1A FOR DETAILED DIAGRAM OF STEERING WORM ASSEMBLY AND PARTS LIST	
4-6	87-073-00	Grease Fitting - 3/16" Drive Typer 45°	2
4-7	88-130-14	7/16 x 1-1/2 NF Hex Hd Screw	3
4-8	88-128-60	Washer 7/16" Flat	3
4-9	88-130-86	7/16" NF Fiber Insert Locknut	3
4-10	18-104-00	Steering Lever	1
4-11	87-074-00	Grease Fitting 1/4" - 28 THD (Straight)	6
4-12	86-501-98	Ball Joint (Left Hand Thread) TIRE ROD END	2
4-12	86-501-99	Ball Joint (Right Hand Thread) TIRE ROD END	2
4-13	87-071-00	Grease Fitting 3/16" Drive Type (Straight)	2
4-14	88-159-85	Castle Nut 1/2" NF (Hex)	4
4-15	88-527-11	Cotter Pin 1/8 x 1"	4
4-16	86-510-00	Ball Joint Clamp	4
4-17 18-057-11	18-055-11	Steering Adjustment Sleeve (27" Long)	1
4-17 18-057-10	18-055-10	Steering Adjustment Sleeve Assembly with Ball Joint & Clamps (13" Long)	1
4-18	18-041-00	Steering Adjustment Sleeve (22-1/2" Long)	1
4-18	18-041-10	Steering Adjustment Sleeve Assembly with Ball Joints & Clamps (22-1/2" Long)	1
4-19	15-049-10	Assembly Front Axle, Spindles, Hubs, Steering Stops & Tie Rod	1
4-19	15-049-12	Assembly, Front Axle for Hyd. Brakes with Spindles, Hubs, Steering Stops, Tie Rod and Brake Assemblies	1
4-20	88-527-14	Cotter Pin 1/8" x 1-1/2"	2
4-21	88-151-16	1/2 x 2 NF Hex Hd Screw, Grade 5	2
4-22	88-159-82	1/2 NF Jam Nut	2
4-23	45-338-00	Oil Seal	2
4-24	80-017-00	Tapered Roller Bearing	2
4-25	80-103-00	Tapered Bearing Race	4
4-26	12-124-00	Front Hub with Two Bearing Races, One Bearing and One Oil Seal - Five 1/2 NF Studs on 4-1/2" Bolt Circle (Not used with Front Brakes)	2

FIG. I.D. NO.	T-D PART NO.	DESCRIPTION	QTY. REQ.
4-27	96-329-00	Lug Bolt 1/2" NF (96-333-00 - 7/16 NF Used on Earlier Models)	10
4-28	97-236-00	Lug Nut 1/2 NF (97-235-00 - 7/16 NF Used on Earlier Models)	10
4-29	88-228-60	Washer, 3/4	2
4-30	88-239-85	Castle Nut 3/4" N.F. (Hex)	2
4-31	92-104-00	Dust Cap with Grease Fitting	2
4-32	10-081-00	Tire - 5.70 x 8, 4 Ply, Super Rib, Tubeless	2
4-32	10-082-00	Tire - 5.70 x 8, 4 Ply, Xtra Grip, Tube Type	2
4-32	10-088-00	Tire - 5.70 x 8, 8 Ply Steel Guard	2
4-33	11-040-00	Tube - 5.70 x 8, (Can be Used with Tubeless Tire)	2
4-33	11-041-00	Tube - 18 x 8.50 x 8 or 18 x 9.50 x 8 (Optional for Tubeless Tire)	2
4-34	12-012-00	Wheel for 5.70 x 8 Tire (Five 1/2" Holes on 4-1/2" Bolt Circle - for Tubeless or Tube Type Tire)	2
4-34	12-042-00	Wheel, Split Disc, for 5.70 x 8 Steel Guard Tire (Five 1/2" Holes on 4-1/2" Bolt Circle)	4
4-35	13-742-12	Tire Tube & Demountable Wheel 5.70 x 8, 6 Ply	2
4-35	13-742-13	Tire - Tubeless and Demountable wheel, 5.70 x 8, Load Range C, Hwy. Thread, 5 Hole Pattern	2
4-35	13-742-00	Tire, and Demountable Wheel, 5.70 x 8, 4 Ply Super Rib Tire (Five 1/2" Holes on 4-1/2" Bolt Circle)	2
4-35	13-744-00	Tire, Tube and Demountable Wheel, 5.70 x 8, 4 Ply, Extra Grip Tire (Five 1/2" Holes on 4-1/2" Bolt Circle)	2
4-35	13-745-00	Tire, Tube and Demountable Wheel 5.70 x 8, 8 Ply Steelguard Tire (Five 1/2" Holes on 4-1/2" Bolt Circle on Wheel)	2
4-36	12-020-00	Wheel for 18 x 8.50 x 8 or 18 x 9.50 x 8 Tire (Five 1/2" Holes on 4-1/2" Bolt Circle)	2
4-37	10-093-00	Tire 18 x 8.50 x 8, 4 Ply, Terra Tire, Power Rib Tubeless	2
4-38	13-746-00	Tire and Demountable Wheel, 18 x 8.50 x 8, 4 Ply Terra Tire, Power Rib (Five 1/2" Holes on 4-1/2" Bolt Circle)	2
4-39	12-050-00	Wheel for 18 x 5 x 12-1/8 Solid Cushion Tire (Five 1/2" Holes on 4-1/2" Bolt Circle)	2
4-40	10-260-00	Tire-Solid Extra Cushion, All Service 18 x 5 x 12-1/8	2
4-41	13-955-10	Tire & Demountable Cast Iron Wheel, 18 x 5 x 12-1/8 Solid Extra Cushion. All Service Tire (Five 1/2" Holes on 4-1/2" Bolt Circle on Wheel)	2
4-42	96-120-00	"U" Bolt Front Axle with Four Leaf Spring	4

FIG. I.D. NO.	T-D PART NO.	DESCRIPTION	QTY. REQ.
4-43	16-858-00	Spring Pad	2
4-44	88-149-81	Lock Nut ½" NC (Hex)	14
4-45	85-498-00	Leaf Spring Unit (26" Centers - Four Leaf)	2
4-46	98-601-00	Grommet, Rubber	12
4-47	16-872-00	Shackle Strap	4
4-48	96-240-00	1/2 x 4 NC Hex Cap Screw (Pointed)	6
4-50	21-009-00	King Pin	2
4-51	14-099-98	Spindle Assembly, Including Bronze Bushings and Grease Fitting - Left Side	1
4-51	14-099-99	Spindle Assembly, Including Bronze Bushings and Grease Fitting - Right Side	1
4-52	32-204-00	Bronze Bushing (Without Flange)	2
4-53	32-200-00	Bronze Bushing (With Flange)	2
4-54	80-309-00	Thrust Bearing	2
4-55	88-279-81	7/8 NF Hex Head Lock Nut	2
4-56	14-163-98	Front Spindle Assembly with Brake Mount - Left	1
4-56	14-163-99	Front Spindle Assembly with Brake Mount -Right	1
4-57	41-601-00	Brake Shoe and Lining Set (2 Lined Brake Shoes)	2 Sets
4-58	42-051-00	Brake Adjustment Unit with 2 Studs	2
4-60	85-206-00	Extension Spring - 3/8 OD x 3-3/8 Long (Black) Bottom	2
4-61	88-068-62	1/4" Lock Washer	4
4-62	85-205-00	Extension Spring - 5/16 OD x 4½ Long (Red) Top	2
4-63	99-501-00	Wheel Cylinder	2
4-64	85-050-00	Compression Spring, 9/16 OD x 1/2 Long (Green)	4
4-66	42-048-62	Kit, Wheel Cylinder Retainers & Dust Cover	2
4-69	41-512-01	Drum	2
4-70	12-158-00	Wheel Hub (Used only with Front Wheel Brakes)	2
4-71	88-079-80	1/4 NF Hex Nut	4
4-72	98-602-00	Grommet, Rubber 1½" I.D.	1

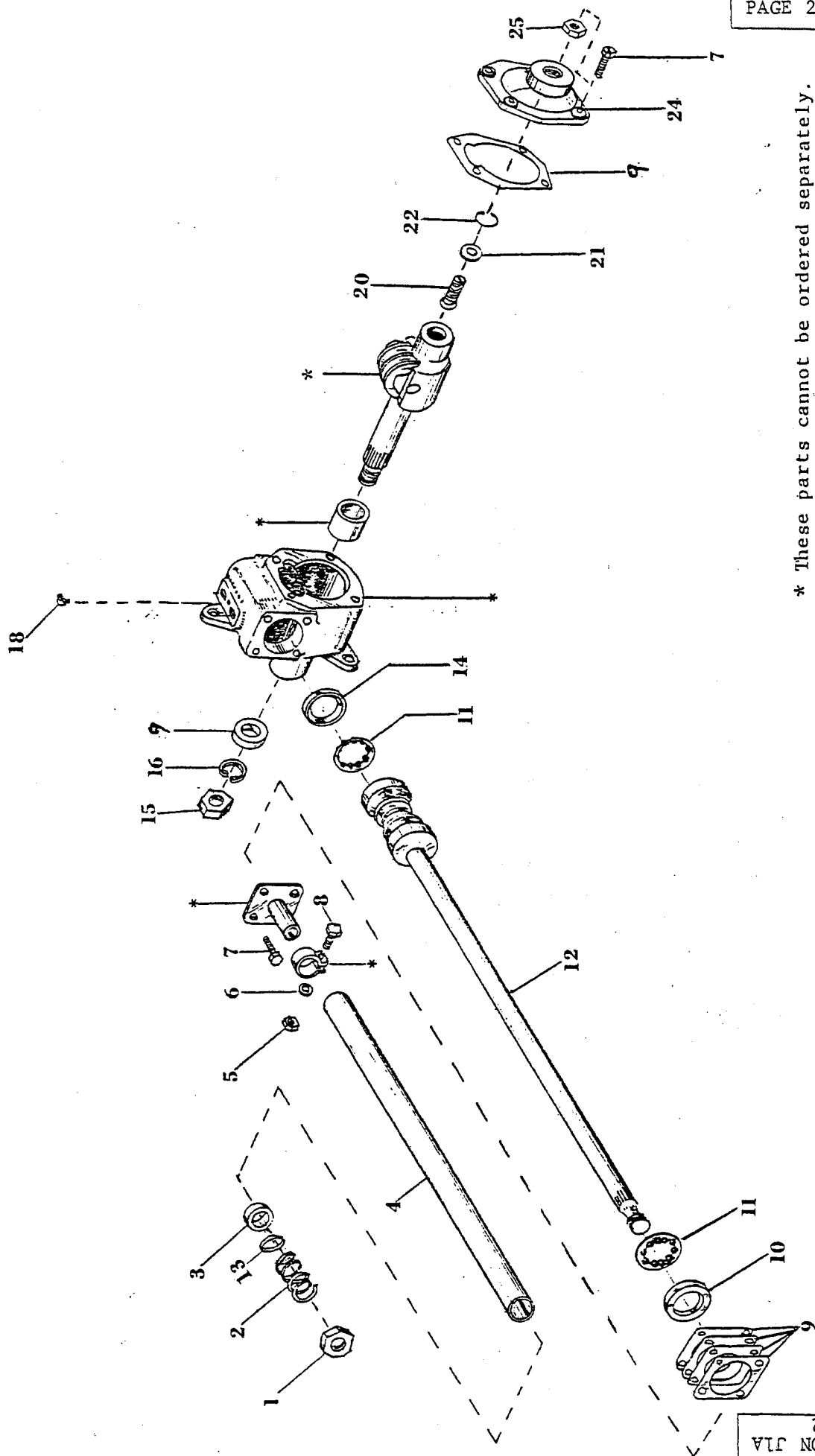

* These parts cannot be ordered separately.
Order as part of the entire steering unit
assembly, part # 18-307-14

LENGTH | QUAN. | REVISED DATE | REVISION

FIGURE 4A
SECTION J1A

STEERING WORM ASSEMBLY



TAYLOR DUNN MFG. CO.
2114 West Ball Rd.
Palo Alto, Calif.

NO.	DESCRIPTION
TOL. FRAC. †	DEC. †
SCALE	NONE
DRAWN I	2-11-77
DATE	

STEERING WORM ASSEMBLY
REFER TO FIGURE 4A

FIG. I.D. NO.	T-D PART NO.	DESCRIPTION	QTY. REQ.
4A-0	18-307-14	Steering Gear - this part number no longer valid - see BUL-98-09-011	
4A-1	88-259-82	Nut, Jam 13/16 Hex Head, NF	1
4A-2	85-122-00	Spring, Compression 1-1/8 OD x 1	1
4A-3	18-307-54	Spacer, Jacket Bearing	1
4A-4	18-307-52	Jacket, Steering Column	1
4A-5	88-099-80	Nut, 5/16 NF	1
4A-6	88-088-62	Washer, Lock	1
4A-7	88-080-09	5/16 x 3/4 NC Hex Hd Cap Screw	8
4A-8	(Not Available)	5/16 x 2 NF Hex Hd Cap Screw	1
4A-9	18-307-42	Gasket, Seal & Shim Kit for Steering Worm	1
4A-10	18-307-57	Worm Adjustment Bearing Cup, Inner (Requires 18-307-42)	1
4A-11	18-307-53	Worm Bearing Assembly (Requires 18-307-42)	2
4A-12	18-307-51	Steering Column Shaft & Worm Assembly (Requires 18-307-42)	1
4A-13	18-307-55	Spacer, Jacket Bearing	1
4A-14	18-307-56	Worm Bearing Cup, outer (Requires 18-307-42)	1
4A-15	88-279-82	Nut, Jam 7/8 NF Hex	1
4A-16	88-268-62	Lockwasher, 7/8	1
4A-17	18-307-59	Seal, Steering Arm Shaft	1
4A-18	87-073-00	Fitting, Gear 45 degree, 3/16 drive	1
4A-20	18-307-64	Screw, adjusting	1
4A-21	18-307-65	Washer, Thrust	1
4A-22	18-307-66	Snap Ring	1
4A-24	18-307-67	Shaft Cover	1
4A-25	88-159-82	Nut, Jam 1/2" NF	1

MAINTENANCE PROCEDURES
REFER TO FIGURE 5

"POWER TRACTION" REAR AXLE, MOTOR AND BRAKES

Your "Power Traction" direct drive assembly is a highly efficient unit. Great care was taken in its design to promote long life with a minimum of maintenance. It employs an automotive type differential unit which operates within an enclosed housing. The gears, bearings, etc. are lubricated from within by oil which when maintained at its proper level insures complete coverage of all moving parts. This oil level should be checked on a regular basis as outlined in the Maintenance Guide (Section D) and lubrication diagrams (Section E) of this manual. If the oil level is allowed to drop below normal limits serious damage to the differential and drive unit will result.

An adjustable motor mount has been provided to extend normal chain life. Refer to Section J2 Page 7 for proper adjustment procedures. It is important to adhere to the adjustment schedule included on Page 8. Failure to do so will seriously effect normal chain life.

The electric motor will provide many hours of trouble free service. It is provided with sealed ball bearings which are pre-lubricated for their lifetime. (Consult Section J2M for maintenance and parts listing).

Periodically, the motor brushes should be inspected and cleaned. The carbon dust and dirt should be blown out of motor. When brushes are worn they should be replaced. Approximately 3000 hours operating life may be expected from a new set of brushes. To determine when to replace worn brushes, proceed as follows:

1. For motors equipped with brushes having end pigtailed and side hooks, replace brush when hook is within 1/16" from bottom of hook slot.
2. For motors equipped with brushes having side pigtailed only, replace brush when pigtail is within 1/16" from bottom of pigtail slot.

NOTE: When one brush is replaced in a motor, it is considered good maintenance practice to replace all brushes.

Inspect commutator for roughness or undue wear as arcing and shortend brush life will result from this condition.

Check wiring terminals for cleanliness and tightness. A loose connection will cause burning of the respective terminal and can induce motor failure.

Refer to Maintenance Guide (Section D) and Service and Adjustment (Section J2) for further recommendations on motor care.

The mechanical brake assembly located on the differential pinion shaft will require a periodic inspection for lining wear and consequently periodic adjustment. Refer to Service and Adjustment Section J2 of this manual for proper procedures.

A few drops of oil on the clevis pin and pivot pins of the mechanical linkage is recommended on a monthly basis. Great care must be taken that no oil is allowed to contact the brake band or drum as it will seriously impair the braking ability. If the braking surfaces become oily or contaminated for any reason it will be necessary to remove the brake band and clean all parts thoroughly. Refer to the appropriate section of this manual for the correct procedure to follow.

If your vehicle is equipped with hydraulic brakes refer to Section J3 for their care and adjustment.

A periodic tightening of all bolts and nuts, especially the spring mounting "U" bolts should be made.

The normal life of the shock absorber unit is approximately 2 Years.

SERVICE AND ADJUSTMENTS
REFER TO FIGURE 5
"POWER TRACTION" REAR AXLE, MOTOR AND BRAKES

Adjustment of Brake (Minor) To Compensate For Normal Lining Wear. Important Note.

Observe position of Brake Lever Arm. It must be 1/16" to 1/4" from Gear Case Cover with brake pedal and hand brake fully released.

If brake lever arm is not in the correct position, due to improperly adjusted cables or brake rods, then it will be necessary to perform a complete major brake adjustment as itemized under next section "Adjustment of Brakes (Complete)".

Note: If brake lever arm is in the correct position as described above, it will not be necessary to touch cable or rod adjustments.

1. Adjust brake band anchor bolt and nut, tightening it until brake pedal travels approximately half way to floorboard engaging brake sufficiently to stop vehicle. Vehicles equipped with automatic (deadman) brake requires the treadle to operate the braking action within the last 1/4 of its stroke.
2. Adjust centering screws, centering band around drum to bring band as close to drum as possible without brake dragging. Lock centering screw. If band is too far from brake drum, brakes will grab in the forward direction.

CAUTION: Never bend the brake band anchor bolt. Any bending of the bolt may result in unexpected failure of the bolt and complete loss of Drive Line braking Action.

Adjustment of Brake (Complete Except for Automatic (Deadman) Brake Refer to Section J4

1. Loosen clevis and locknut on foot brake, cable (or rod) and adjust length to position brake lever arm 1/16" to 1/4" from gear case cover as described above. It may be necessary on vehicles equipped with other control cables such as handbrake cables to disconnect them so they will not interfere with this first important adjustment.
2. Adjust brake band as outlined in steps 1 and 2 and CAUTION note above.
3. Adjust hand parking brake lever knob on end of handle, turning counterclockwise until it stops. Place lever in locked position. Then loosen clevis locknut on cable or rod on underside of parking brake lever and adjust cable or rod (by shortening) until brake band engages drum properly. Lock clevis nut.

NOTE: Brake band and brake cable must be adjusted first as outlined above.

4. Try completely releasing hand lever to be certain brake band is completely released. Additional brake holding power can be applied by turning knob on end of handle in clockwise direction.

NOTE: Turning knob in clockwise direction increases travel of brake cable but decreases leverage of brake lever. Therefore, if it is adjusted too far clockwise the lever will be difficult to operate. You compensate for this condition by shortening hand brake rod as outlined above. Caution: If you shorten rod too far, you will not allow the brake band to completely release. Obviously the ideal condition is midway between the two extremes described above.

5. If vehicle is equipped with hydraulic wheel brakes, refer to Section J3 for service and adjustment.
6. If vehicle is equipped with brake-accelerator lock, refer to Section J4 for service and adjustment.
7. If vehicle is equipped with Automatic (Deadman) brake, refer to Section J4 for service and adjustment.

Removal of Brake Assembly and Drum

1. Remove cotter pin and clevis pin, disconnecting cable from brake lever arm, (note location of clevis). Remove lever arm return spring.
2. Remove 4 bolts holding brake mounting assembly and slide assembly off drum.
3. Band and drum may now be clean, inspected, and if necessary parts may be replaced as needed.
4. Brake band lining is bonded to the band for long dependable service. When it wears to approximately 1/16" thickness the band should be replaced.
5. If the brake drum is scored, it should be removed and turned. It is recommended that a brake drum that has been severely scored or damaged should be replaced with a new drum.
6. Inspect seal in gear case cover. If worn or damaged, replace with new one. It is recommended that new seal be pre-soaked in light oil for several hours before installation. Use small amount of oil resistant sealer on seal opening in cover when pressing seal into place.
7. Re-assemble drum and spacer on pinion shaft. Tighten to 100 lb. ft. torque.
8. Replace brake assembly in the reverse order to which it was removed.
9. Adjust brake band and cables as outlined on page 2.

Removal of "Power Traction" Rear Axle & Drive Assembly From Chassis.

1. CAUTION: Disconnect both main battery leads to prevent accidental engagement of power while servicing unit.
2. Clearly mark motor leads to insure their proper location when re-assembling.
3. Remove motor leads.
4. Pull clevis pin and disconnect brake cable from brake arm.
5. Remove lower bolt from shock absorber. (Only vehicles equipped with shock absorbers).
6. Disconnect hydraulic brake line at hose end. (Only vehicles equipped with hydraulic brake).
NOTE: Steps 7 and 8 refer to vehicles with spring suspension.
7. Remove "U" Bolt clamp and nuts attaching spring to frame.
8. Remove spring eye anchor bolts.
9. Remove 4 bolts attaching power traction assembly to frame (Only on unsprung type vehicles).
10. Remove axle and drive assembly from chassis.
11. Install axle and drive assembly in the reverse order of removal, taking care that support pads and rubber bushings are in good condition. (Replace if worn or damaged).
12. Check brake adjustments as previously outlined on page 3.
13. On models equipped with hydraulic brakes, it will be necessary to bleed the air from brake system. Follow procedure outlined in Hydraulic Brake Section J3 of this manual.

Disassembly of "Power Traction" Rear Axle

1. Remove unit from chassis. (As previously outlined)
2. Remove wheels and drain oil from housing.
3. Lock drive shaft brake by pulling brake lever. Remove pinion nut and pull off brake drum.
4. Remove four bolts and spring and lift off brake assembly.
5. Remove remaining nuts and bolts, and remove drive case cover.
6. Remove 3 nuts and washers and remove motor and mount plate. (If motor requires further service, refer to appropriate Section J2 of this manual).
7. Remove chain and pinion sprocket. Observe location of spacers on shaft. Refer to Figure 5 for their correct location.
8. Remove five bolts holding back plate and remove from carrier housing.
9. On hydraulic brake models, remove brake drums, disconnect hydraulic line, remove brake shoe return springs (orange color) and remove wheel cylinders.
10. Remove four bolts on each end holding axle retainer (and brake backing plate on hydraulic brake models) and pull both axles.
11. Remove nuts around differential carrier housing and remove carrier from axle housing. (Note position of clip for proper reassembly of brake spring.).
12. Mark one differential bearing cap and bearing support to insure proper assembly. Remove adjusting nut locks, bearing caps, and adjusting nuts.
13. Remove drive gear from differential case.
14. Drive out differential pinion shaft retainer and separate the differential pinion shaft and remove gears and thrust washers.
15. Remove drive pinion retainer from carrier. Remove O-ring from retainer.
16. Remove pinion locating shim. Measure shim thickness with micrometer.
17. If the drive pinion pilot bearing is to be replaced, drive the pilot end and bearing retainer out at the same time. When installing, drive the bearing in until it bottoms. Install a new retainer with the concave side up.
18. Press the pinion shaft out of front bearing cone and remove spacer.
19. Remove pinion bearing cone.
20. Do not remove pinion bearing cups from retainer unless they are worn or damaged. The flange and pilot are machined by locating on these cups after they are installed in the bores. If new cups are to be installed, make sure they are seated in the retainer by trying to insert a .0015" feeler gauge between cup and bottom of bore.

Re-Assembly of Power Traction Rear Axle

1. Differential Case: Place a side gear and thrust washer in the differential case bore. LUBRICATE ALL PARTS LIBERALLY WITH AXLE LUBRICANT DURING ASSEMBLY. With a soft faced hammer, drive pinion shaft into case only far enough to retain a pinion thrust washer and pinion gear. Place the second pinion and thrust washer in position. Drive the pinion shaft into place. Be careful to line up pinion shaft retainer holes. Place second side gear and thrust washer in position and install differential case cover. Install retainer, A pinion or axle shaft spline can be inserted inside gear spline to check for free rotation of differential gears. Insert two 7/16" x 2" bolts through differential flange and thread them three or four turns into the drive gear as a guide in aligning the drive gear bolt holes. Press or tap the drive gear into position. Install and tighten the drive gear bolts evenly and alternately across the gear to 60-65 lb. ft. torque
2. If the differential bearings have been removed, use a suitable press to install them.
3. Pinion and Retainer: Install pinion rear bearing cone on the pinion shaft. Install spacer with shims on shaft. Place the bearing retainer on the pinion shaft, and install the front bearing cone.
4. Lubricate both bearings with differential oil. Place spacers, sprocket and brake drum on spline with nut and washer and tighten to 100 lb. ft. torque.
NOTE: The bearing should spin free but have no play. If tight or loose, adjust with .005" and .019" shims.
5. Shim Selection: Manufacturing tolerances in the pinion bore dimensions and in the best operating position of the gears make an adjustment shim necessary. This shim is placed between the pinion retainer and the carrier, Fig. 5. An increase in the thickness of the shim moves the pinion AWAY from the drive gear. Manufacturing objectives are to make axles requiring a .0015" shim and if a new assembly is being built, a .0015" shim should be used for a tentative build-up. Shims are available in .010" to .021" thicknesses in steps of .001". Pinions and drive gears are marked, when matched, with the same number. Following the number on the pinion is a minus (-) or (+) followed by a number. If the pinion is marked "-1" it indicates that a shim .001" thinner than a standard shim for this carrier is required. A minus number means the pinion should be moved closer to the drive gear and a thinner shim is required. A plus number means the pinion should be moved farther from the drive gear and a thicker shim is required. A pinion marked zero (0) is a standard pinion. To select a shim, measure the original shim with a micrometer Note the dimensional mark on the original pinion. Compare the mark on the original pinion with the mark on the new pinion to determine how the original shim should be modified. For example, if the original shim is .015" and the original pinion is marked "-1", the new pinion requires a +1 shim. Therefore, the new pinion requires a .002" thicker shim, and a .017" shim should be used. If the new pinion is marked the same as the old pinion, no shim change is required.

6. After the proper selection of shims, insert "O" ring seal and pinion retainer assembly into differential carrier. Tighten 5 retainer bolts to 50 lb. ft. torque. (Note: The 5 bolts will have to be removed later to install back plate assembly.)
7. Install differential case, bearing cups, adjusting nuts, and bearing caps being sure that each cap is located in the same position from which it was removed. (Use marks as guide)
8. ADJUST bearing nuts so that differential case will be free to revolve. It is very important that there will be no bearing play or looseness, as this will inevitably lead to gear noise and wear. Gear backlash must be set at the same time to a tolerance of .005" to .009". Note: It will be necessary to release some of the cap bolt tension in order to allow the bearing to move while making the adjustments. If the caps are too loose an error will result when trying to set backlash and bearing clearance. Therefore double check your setting after the cap bolts have been tightened. If necessary make corrections in your settings until the specified tolerances are maintained after the cap bolts have been tightened.
9. Install nut locks.
10. Install differential carrier assembly in axle housing using new gasket and gasket sealer.
11. Install axles, brake assemblies (on models with hydraulic brakes), bearing retainers, and gaskets. Note: Axles are equipped with special sealed bearings. Should there be evidence of seal leakage, it is recommended that a new bearing and new bearing retainer ring be pressed onto the axle shaft, and a new gasket be installed between the bearing and bearing seat in the housing. Refer to Figure 5.
12. Remove pinion nut, spacers, brake drum, and sprocket. Remove 5 bolts from pinion bearing retainer.
13. Install gasket (use gasket sealer) and back plate assembly. Tighten 5 bolts to 50 lb. ft. torque.
14. Install spacers, sprockets and chain in the reverse order to which they were removed. Take care that 3/16" woodruff key is in proper position and all spacers are in original position. Tighten 3/4" motor shaft nut to 75 lb. ft. torque (if sprocket was removed from motor).
15. Install motor and motor mount plate with "O" ring. Do not tighten 3 nuts until final adjustment is made. Be sure motor terminals are located in the same position as when motor was removed.
16. If seal is worn or damaged in gear case cover, replace with new seal. It is recommended that new seal be pre-soaked in light oil for several hours before installation. When pressing new seal into cover use small amount of oil resistant sealer on seal opening in cover.

17. Install gear case cover to backplate and pinion shaft. Assemble, but do not tighten, retaining bolts and nuts.
18. Place centering tool 41-532-50, (for centering pinion shaft seal to brake drum hub) on pinion shaft and into seal retainer.
NOTE: If centering tool is not available, slide brake drum onto pinion shaft and into seal. Install pinion shaft washer and nut and tighten to 100 ft. lb. Position gear case cover so that seal pressure is uniform around hub of brake drum. Tighten gear case cover retaining bolts and nuts. Omit Steps 19 through 22.
19. Install pinion shaft washer and nut, and tighten to 100 ft. lb. torque.
20. Tighten gear case cover retaining bolts and nuts.
21. Remove pinion shaft nut and washer, and remove centering tool.
22. Install brake drum, washer, and pinion shaft nut. Tighten nut to 100 ft. lb. torque.
23. Install brake band, brake band anchor bracket, and brake band centering brackets to gear case cover, and tighten retaining bolts.
24. Replace wheels and fill chain and differential housing with approximately 2 qts. SAE 20 oil.
25. Replace unit in chassis following steps 11 to 13 outlined in Section titled Removal of "Power Traction" Rear Axle.
26. Adjust motor mount plate (as outlined in Motor Adjustment Section following) to proper chain tension.

Adjustment of Motor Mount to Tension Chain

1. Tighten three motor mount nuts.
2. Loosen and unscrew each nut exactly one full turn.
Note: This procedure is very important for if the nuts are too loose or too tight an error will result in the final adjustment which will seriously effect the life of the chain.
3. Loosen adjusting set screw lock nut. Using standard socket set screw wrench turn set screw clockwise until tight. (If a torque wrench is available tighten to 80 inch lbs. torque.) Without a torque wrench bear in mind that a standard socket set screw wrench is approximately 4" long. An average person will only be able to develop the required torque necessary if he tightens it as far as possible with his hands and does not use any extended handle on the wrench.
4. After developing the required torque, unscrew the adjusting screw exactly 2½ turns. It is also very important to be exact on this adjustment.
5. Tighten locknut, DO NOT allow adjusting screw to move while tightening locknut.
6. Be certain that motor has moved all the way back and adjusting screw is in contact with back plate. If necessary tap motor lightly to assure this condition.
7. Tighten three motor mount nuts securely.

perform this adjustment procedure regularly as listed below to assure long and trouble free life from your "Power Traction" Drive.

Scheduled Adjustment	Hours Running	Comments
1st Adjustment	0	New Unit or After Installing New Chain
2nd "	Next 100 Hrs.	Normal Running Conditions
3rd "	Next 150 Hrs.	" " "
4th "	Next 250 Hrs.	" " "
Thereafter	Every 400 Hrs.	" " "

Removal of Motor For Minor Repairs

1. **CAUTION:** Disconnect both main battery leads to prevent accidental engagement of power while servicing unit.

2. Drain oil from gear case by removing drain plug.
3. Unhook brake spring.
4. Remove all bolts & nuts around gear case cover.
5. Remove brake band assembly with brake cables attached. Place assembly on floor under chassis.
6. Remove pinion nut, washer & brake drum.
7. Remove gear case cover.
8. Clearly mark motor leads to insure their proper location when re-assembling. Remove motor leads.
9. Remove 3 nuts & washers and remove motor & mount plate.
10. If replacing motor, remove nut, washer, sprocket, and spacers. Also remove motor mount plate. Note: Observe location of motor terminals in relation to motor mount plate.

Install Motor in "Power Traction" Drive.

It is not necessary to remove motor mount plate when performing minor motor repairs. Therefore, follow step 1 only when replacing motor with new one.

1. Clean motor surface and install mounting plate with four flat head cap screws. Tighten to 30 lb. ft. torque. Stake head in place with centerpunch. Note: It is important to locate the motor mount plate in relation to the motor terminal so that the motor terminals will be in an accessible location when drive is completely assembled.
2. Place "O" ring into motor mount plate opening and attach motor and plate to back plate.
3. Re-assemble drive in the reverse order to that of removal.
4. Adjust motor mount to obtain proper chain tension.
5. Refill gear case with SAE 20 oil.

6. Correct Motor leads as follows: (Important !!)

- a). Check that each motor terminal stud nut is tightened securely but not over-tightened as this could bend or twist the terminal post and cause an electrical short within the motor.
- b). Install motor leads on correct motor terminals post.
- c). Install a second nut on each terminal post & finger tighten.
- d). To avoid bending, twisting or breaking-off a terminal post, use a thin pattern 9/16" wrench to hold the bottom nut from moving while tightening the top nut. Carefully tighten the top nut so as to make a good connection between the terminal post and motor lead.

Motor Repairs.

Unless the maintenance man is properly qualified, it is advisable that repair work be done at a qualified service station. When ordering replacement parts, give complete name plate data.

Disassembly of Motor (Refer to Section J2M).

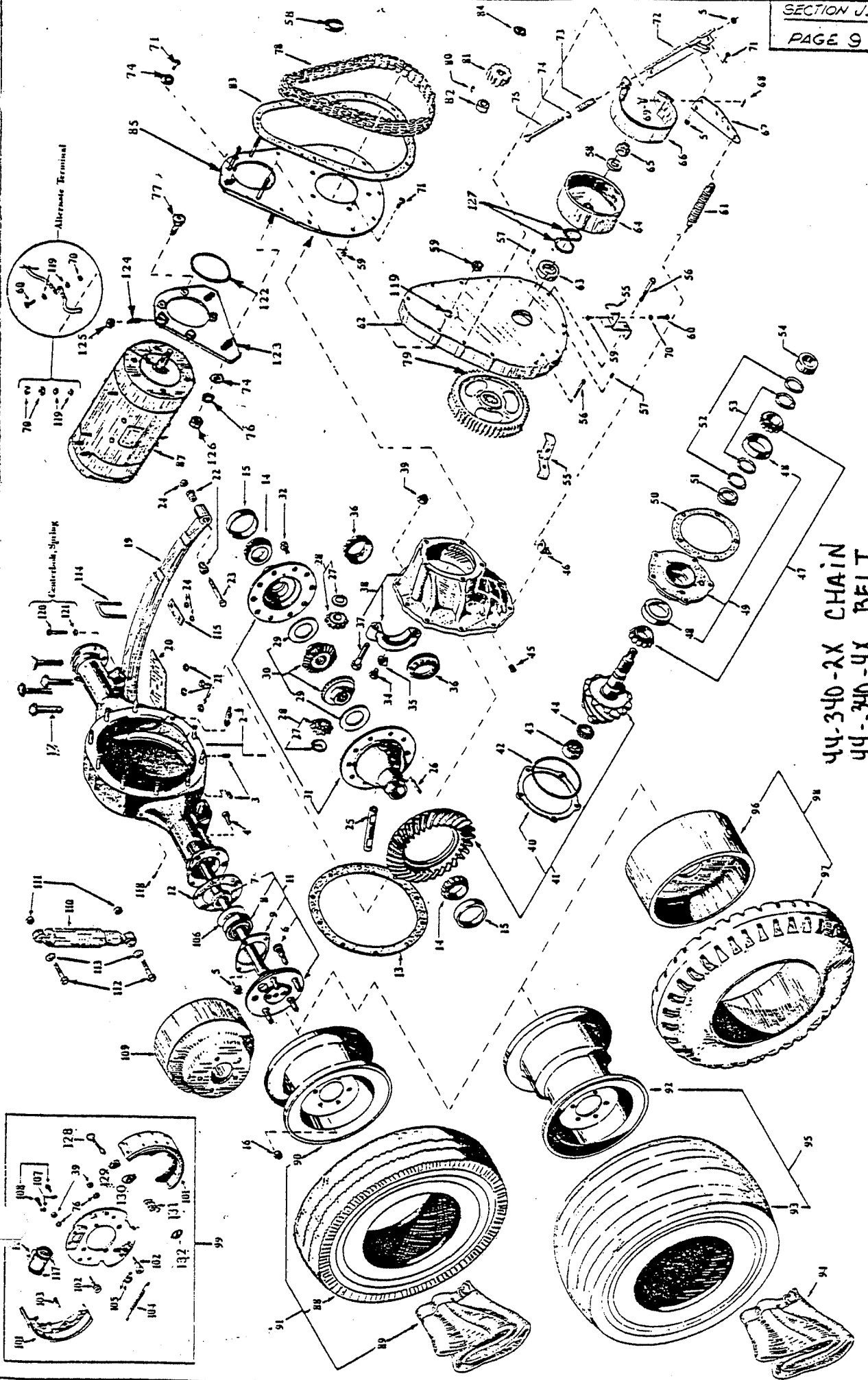

44-340-2X CHAIN
44-340-4X BELT

LENGTH | QUANTITY | REVISED DATE | REVISION

"POWER TRACTION"
REAR AXLE, MOTOR & BRAKES

FIGURE 5
SECTION J2

NO. DESCRIPTION	TOL. FRAC. ±	DEC. ±
SCALE NONE		
DRAWN BY RVD		
DATE 6-13-78		

TAYLOR DUNN MFG. CO.
2114 West Ball Rd.
Anaheim, Calif.



POWER TRACTION DRIVE AXLE
REFER TO FIGURE NO. 5

FIG. I.D. NO.	T-D PART NO.	DESCRIPTION	QTY. REQ.
5-1	41-291-00	Housing, Rear Axle	1
5-2	96-330-00	Bolt-Differential Carrier to Housing	10
5-3	41-997-00	Drain and Level Plug (1/8 Pipe)	2
5-4	88-100-11	3/8 x 1 N.C. Hex Head Cap Screw	14
5-5	88-109-81	3/8 N.C. Lock Nut	18
5-6	96-331-00	Bolt - 1/2 N.F. Rear Hub	10
5-7	32-509-00	Retainer Ring, Rear Axle Bearing	2
5-8	80-505-00	Ball Bearing, Rear Axle	2
5-9	32-511-00	Retainer Plate, Rear Axle	2
5-11	41-160-11	Axle, Rear 22-3/8" Overall Length, Including Studs, 28 Teeth on Spline, F2 with Bearing, Retaining Plate, Retaining Ring, Small Bearing with Gasket	1
5-11	41-161-11	Axle, Rear 13-1/4" Overall Length, Including Studs, 28 Teeth on Spline, F2 with Bearing, Retaining Plate, Retaining Ring, Small Bearing with Gasket	1
5-12	32-512-00	Retainer Spacer (Used only <u>without</u> Hydraulic Brakes)	2
5-13	45-042-00	Gasket, Axle Housing to Differential	1
5-14	80-511-00	Tapered Roller Bearing-Carrier (Small 1.628 ID)	2
5-14	80-512-00	Tapered Roller Bearing-Carrier (Large 1.784 ID)	2
5-14	80-513-00	Tapered Roller Bearing LM 102949, I.D. 1.7812 Use with 80-129-00 Bearing Race	2
5-15	80-127-00	Tapered Bearing Race-Carrier (Small)	2
5-15	80-128-00	Tapered Bearing Race-Carrier (Large)	2
5-15	80-129-00	Tapered Bearing Race LM 102910 O.D. 28910 Use with Bearing 80-513-00	2
5-16	97-236-00	Nut, 1/2" N.F. (Lug)	10
5-17	88-101-18	3/8 x 2-1/2 N.C. Hex Head Cap Screw, GR3, (Heat Treated)	8
5-19	85-510-15	Five Leaf Cantilever Spring Assembly	2
5-20	16-861-00	Pad, Spring 3 x 5 x 1/4 Thick	2

FIG. I.D. NO.	T-D PART NO.	DESCRIPTION	QTY. REQ.
5-21	88-109-87	3/8 N.C. Fastite Nut	20
5-22	98-601-00	Rubber Grommet 1/2" I.D. For Leaf Spring Eye	4
5-23	96-240-00	Hex Head Cap Screws 1/2" x 4" N.C. (Pointed)	2
5-24	88-149-81	Lock Nut 1/2" N.C. (Hex)	6
5-25	41-700-00	Differential Pinion Shaft	1
5-26	41-701-00	Pin	1
5-27	41-702-00	Thrust Washer - Differential Pinion Shaft	2
5-28	41-703-00	Differential Shaft Pinion Kit (Two Differential Gears and Two Thrust Washers)	1 Kit
5-29	41-704-00	Thrust Washer - Differential Side Gear	2
5-30	41-705-00	Differential Side Gear Kit (Two Differential Side Gears and Two Thrust Washers)	1 Kit
5-31	41-712-00	Differential Gear Case Assembly (Small Carrier Bearings 1.628" I.D.)	1
5-31	41-713-00	Differential Gear Base Assembly (Large Carrier Bearings 1.784" I.D.)	1
5-32	96-243-00	Hex Head Cap Screw 7/16" x 7/8" N.F., H.T.	10
5-33		Intentionally Left Blank	
5-34		Hex Head Cap Screw 5/16" x 3/8" N.C.	2
5-35	41-706-51	Nut Lock, Diff. Bearing Adjustment with Right Angle Tab W/Last Bend 1/2" Long. Use W/ 41-708-50 Diff. B. Adj. Nut	2
5-35	41-706-00	Differential Bearing Adjustment Nut Lock	2
5-35	41-706-50	Nut Lock, Diff. Bearing Adjustment W/right Angle Tab W/Last Bend 1/2" Long. Use W/ 41-707-50 Diff. B. Adj. Nut	2
5-36	41-707-00	Nut-Differential Bearing Adjustment 3-1/8" -16 Thread (For Small Carrier Bearing 1.628" I.D.)	2
5-36	41-708-00	Nut-Differential Bearing Adjustment 3-5/16"-16	2
5-36	41-708-50	Nut-Differential Bearing Adjustment, 3-1/8" O.D, Round Locking Holes. Use with LM 603049 Bearing	2
5-37	88-140-16	Hex Head Cap Screw 1/2" x 2" NC	4
5-38	41-709-00	Differential Carrier Assembly (For Small Carrier Bearing 1.628" I.D.)	1
5-38	41-710-00	Differential Carrier Assembly (For Large Carrier Bearing 1.784" I.D.)	1
5-39	88-119-80	Nut - 3/8" N.F. (Hex)	14

FIG. I.D. NO.	T-D PART NO.	DESCRIPTION	QTY. REQ.
5-40	41-711-00	Shim - Drive Pinion Bearing	1 to 3
5-41	31-235-00	Ring and Pinion Gear Set 2.75 Ratio	1
5-41	31-236-00	Ring and Pinion Gear Set 3.10 Ratio	1
5-41	31-237-00	Ring and Pinion Gear Set 3.25 Ratio	1
5-41	31-238-00	Ring and Pinion Gear Set 3.50 Ratio	1
5-41	31-239-00	Ring and Pinion Gear Set 5.43 Ratio	1
5-41	31-234-00	Ring and Pinion Gear Set 3.00 Ratio	1
5-42	80-702-00	"O" Ring - Drive Pinion Bearing Retainer	1
5-43	80-555-00	Ball Bearing - Rear, Pinion Pilot	1
5-44	41-714-00	Driving Pinion Pilot Bearing Retainer	1
5-45	41-998-00	Plug, 1/2 NPT	1
5-46	91-509-00	Spring Clip	1
5-47	80-554-00	Tapered Roller Bearing - Pinion Shaft	2
5-48	80-125-00	Tapered Bearing Race - Pinion Shaft	2
5-49	44-340-90	Pinion Bearing Case Assembly & Bearing Races	1
5-50	45-021-00	Gasket Gear Case To Pinion Bearing Assembly	1
5-51	16-415-00	Spacer Pinion Shaft (.440" Thick)	1
5-52	16-419-00	Spacer Pinion Shaft (.002" Thick)	2 to 6
5-52	16-410-00	Spacer Pinion Shaft (.018" Thick)	2 to 6
5-53	16-411-00	Spacer Pinion Shaft (.005" Thick)	2 to 6
5-54	16-415-00	Spacer Pinion Shaft (.440" Thick)	1
5-54	16-417-00	Spacer Pinion Shaft (.340" Thick)	1
5-55	41-371-00	Brake Alignment Bracket	2
5-56	88-080-20	Hex Head Cap Screw 5/16" x 3" N.C.	9
5-57	41-989-00	Plug (Filler Level and Drain) 1/4" N.P.T.	2
5-58	88-228-61	Washer 3/4" S.A.E.	2
5-59	88-089-81	Lock Nut 5/16" N.C. (Hex)	14
5-60	88-080-11	Hex Head Cap Screw 5/16" x 1" N.C.	2
5-61	85-270-00	Extension Spring 1-1/4" OD x 4-3/8" Free	1
5-62	43-201-11	Gear Case Cover with Oil Seal	1
5-63	45-331-00	Oil Seal - Gear Case to Pinion	1
5-64	41-532-00	Brake Drum (Splined)	1
5-65	97-250-00	Nut - Pinion 3/4" - 20 Extra Fine Thread	1
5-66	41-661-00	Full Brake Band for 6" Drum	1
5-67	50-656-00	Brake Lever Arm	1
5-68	88-517-11	Cotter Pin 3/32" x 1"	1
5-69	96-771-00	Clevis Pin 3/8" x 3/4" Face to Hole	1
5-70	88-089-80	Nut - 5/16" N.C. (Hex)	10
5-71	88-100-13	Hex Head Cap Screw 3/18" x 1-1/4" N.C.	7
5-72	41-370-00	Brake Mounting Bracket	1
5-73	85-060-00	Compression Spring 5/8" OD x 2-1/2" Long	1
5-74	88-108-60	Washer 3/8" Flat Cut	4

FIG. NO.	I.D.	T-D PART NO	DESCRIPTION	QTY. REQ.
----------	------	-------------	-------------	-----------

5-75		96-245-00	Hex Head Cap Screw 3/8" X 4" N.C.	1
5-76		88-108-62	Lockwasher 3/8"	18
5-77		88-103-09	Flat Head Socket Cap Screw 3/8" X 3/4" N.C.	4

NOTE: The twin roller chain is very different in looks from the side bar chain in that the twin roller chain rides on sprockets having double rows of teeth whereas the side bar type chain rides on sprockets having a single row of teeth.

5-78		30-506-20	Chain, Silent, 36 Links (For 42 Tooth Sprocket)	1
5-78		30-507-20	Chain, Silent, 41 Links (For 59 Tooth Sprocket)	1
5-78		30-508-20	Chain, Silent, 48 Links (For 81 Tooth Sprocket)	1
5-78		30-320-11	Chain, Double Strand, #35 Roller, 96 Pitches, 36" Long, One Piece, Used With 15-81 Ratio Double Tooth Sprockets	1
5-78		30-320-12	Chain, Double Strand #35 Roller, 84 Pitches, 31½" Long, One Piece, Used With 15-60 Ratio Double Tooth Sprockets	1
5-79		30-091-00	Sprocket, Silent Chain, 42 Tooth With Splined Hub	1
5-79		30-092-00	Sprocket, Silent Chain, 59 Tooth With Splined Hub	1
5-79		30-093-00	Sprocket, Silent Chain, 81 Tooth With Splined Hub	1
5-79		30-070-10	Sprocket, 81 Tooth For #35 Double Strand Roller Chain, F2 Splined Hub	1
5-79		30-070-11	Sprocket, 60 Tooth For #35 Double Strand Roller Chain, F2 Splined Hub	1
5-80		97-100-00	Woodruff Key - 3/16"	1
5-81		30-080-00	Sprocket - 15 Tooth X 3/4" Bore	1
5-81		30-081-00	Sprocket - 14 Tooth X 3/4" Bore	1
5-81		30-070-00	Sprocket, 15 Tooth For #35 Double Strand Roller Chain, 3/4" Bore, 3/16 Keyway	1
5-82		17-110-10	Shaft Collar - 3/4" With Keyway	1
5-83		45-002-00	Gasket - Gear Case Cover	1
5-84		88-239-82	Jam Nut - 3/4" N.F. (Hex) for 15 Tooth Sprocket	1

FIG. I.D. NO.	T-D PART NO.	DESCRIPTION	QTY. REQ.
5-84	97-242-00	Special Nut 3/4" N.F. (Hex) For 14 Tooth Sprocket	1
5-85	44-352-51	Gear Case Back Plate (Side Motor Mount) Adjustable	1
5-87	70-049-00	Motor, 2 H.P. at 36V.	1
5-87	70-054-00	Motor, 3.5 H.P. at 36V.	1
5-87	70-061-00	Motor, 5.0 H.P. at 36V.	1
5-91 thru 5-98		REFER TO SECTION J1 FOR TIRE, TUBE, AND WHEEL PARTS LISTING	
5-99	41-346-98	Brake Backup Plate Assembly with Shoes (Left Side)	1
5-99	41-346-99	Brake Backup Plate Assembly with Shoes (Right Side)	1
5-101	41-640-00	Brake Shoes 7" Internal Expanding (Set for One Wheel)	2 Sets
5-102	42-003-00	Brake Adjustment Cam (7" Hydraulic Brake)	4
5-103	85-207-00	Spring, Extension 3/8 x 1-3/8 Free Length (Red) (Not Used When Items 5-128 thru 5-132 are used)	4
5-104	85-208-00	Spring, Extension, 1/2 x 4-1/2" Free Length (Orange)	2
5-105	85-411-00	Spring, Torsion, 1-1/4" Diameter (Blue)	2
5-106	45-044-00	Gasket - Rear Axle Bearing	2
5-107	88-068-62	Washer - 1/4" Lock	4
5-108	88-060-06	Hex Head Cap Screw 1/4" x 1/2" N.C.	4
5-109	41-514-00	Brake Drum (7")	2
5-110	86-000-00	Shock Absorber	1
5-111	88-189-81	Lock Nut 5/8" (Hex)	2
5-112	88-180-18	Hex Head Cap Screw 5/8" x 2-1/2 N.C.	2
5-113	88-188-61	Washer 5/8" SAE	2

FIG. I.D. NO.	T-D PART NO.	DESCRIPTION	QTY. REQ.
5-114	96-103-00	"U" Bolt $\frac{1}{2}$ " x 1-7/8" I.D. x 3 $\frac{1}{2}$ " Overall Length	2
5-115	50-460-00	"U" Bolt Strap	2
5-116	99-506-98	Wheel Cylinder (7" Brake - Left)	1
5-116	99-506-99	Wheel Cylinder (7" Brake - Right)	1
5-117	99-506-61	Wheel Cylinder Repair Kit (7" Brake)	2
5-118	88-527-11	Cotter Pin 1/8" x 1" (Axle Vent)	1
5-119	88-088-61	Washer 5/16" SAE	11
5-120	96-097-14	Centerbolt For 5 Leaf Spring 5/16" NF x 1 $\frac{1}{2}$ " (H.T.)	2
5-121	88-099-80	Nut 5/16" NF (Hex)	2
5-122	80-703-00	"O" Ring Motor Mount Seal	1
5-123	70-454-00	Motor Mount Plate	1
5-124	88-087-11	Socket Set Screw 5/16" NC x 1"	1
5-125	88-069-80	Nut $\frac{1}{4}$ " NC (Hex)	1
5-126	88-109-80	Nut 3/8" NC (Hex)	3
5-127	16-400-00	Spacer 1 $\frac{1}{2}$ " I.D. x .125" Thick	0 - 1 or 2
5-128	41-695-00	Pin, Brake Shoe Anchor	4
5-129	41-697-00	Washer (Rubber) 7/16 O.D. x 1/8 I.D. x 3/32 THK	4
5-130	88-068-61	Washer, $\frac{1}{4}$ SAE	
5-131	85-065-00	Spring, Compression, $\frac{1}{2}$ " O.D. x 1" Long (GREEN)	4
5-132	41-696-00	Cup, Brake Shoe Anchor	
5-133	88-108-63	Lockwasher, 3/8, internal tooth	5

MOTOR MAINTENANCE, SERVICE AND ADJUSTMENT
ELECTRIC MOTORS
REFER TO FIGURE 5H

Detailed service procedures covering maintenance of bearing brushes and commutator are covered in this section. DO NOT PERFORM THIS PROCEDURE WHILE BATTERIES ARE BEING CHARGED.

Maintenance of electric motors should be referred to personnel with experience and equipment. Should it be necessary for you to order replacement parts for your motor, IT IS NECESSARY TO INCLUDE COMPLETE NAMEPLATE DATA WITH ORDER.

MOTOR MAINTENANCE - BRUSH INSPECTION AND REPLACEMENT

1. Remove cover, exposing brush assemblies. Lift brush from holder for inspection.
2. If brushes are worn, remove, install new brushes. Use fine sandpaper to "seat in" new brushes to commutator. To determine when to replace worn brushes, proceed as follows:
 - a. For motors equipped with brushes having end pigtails and side hooks, replace brush when hook is within 1/16" from bottom of hook slot.
 - b. For motors equipped with brushes having side pigtails only, replace brush when pigtail is within 1/16" from bottom of pigtail slot.

NOTE: When one brush is replaced in a motor, it is considered good maintenance practice to replace all brushes.

3. Check operation of each brush to assure that brush slides freely and does not bind in holder.
4. Replace cover.

MOTOR DISASSEMBLY AND REASSEMBLY

1. Remove motor from vehicle as described in section J2.
2. Determine if witness marks on end bell and stator housing are present. If not, mark end bell and housing to assure proper relation of brushes and commutator when reassembling.
3. Remove cover, exposing brush assemblies. Lift brushes from brush holder.
4. Remove bolts holding end bells and remove end bell and rotor. (Pull from shaft extension end). Take care not to damage any coils or armature wires when handling motor parts.
5. Press or pull old bearings off by using bearing press or bearing puller. Do not damage shaft while removing bearings.
6. Install new bearings onto shaft by gentle pressure or tapping with proper tool on inner race only. Bearing will be damaged if pressed or driven by outer race or seals.
7. If the commutator is worn or "burned" it should be turned, the mica undercut and the commutator polished.
8. Oil bearing housing lightly to aid in reassembly.
9. Reassemble motor taking care that all parts are kept clean.
10. Install brushes and "seat in" with fine sandpaper.
11. Check operation of each brush to assure that brush slides freely in holder.
12. Replace cover.
13. Reassemble to vehicle as described in preceding subsection.

NOTE: If motor terminal studs were removed for inspection, refer to section J2, Page 8, item 6, for correct procedure to avoid damaging studs.

TAYLOR DUNN MFG. CO
2114 West Ball Rd.
Anaheim, Calif.

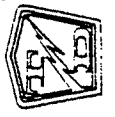

MOTOR PARTS - G.E. MOTORS

LENGTH | QUANTITY | REVISED DATE | REVISION

FIGURE 5M
SECTION J2M

NO.	DESCRIPTION
TOL. FRAC. ±	DEC. ±
SCALE	NONE
DRAWN BY	B.B.
DATE	4-1-80

SECTION J2M
PAGE 2

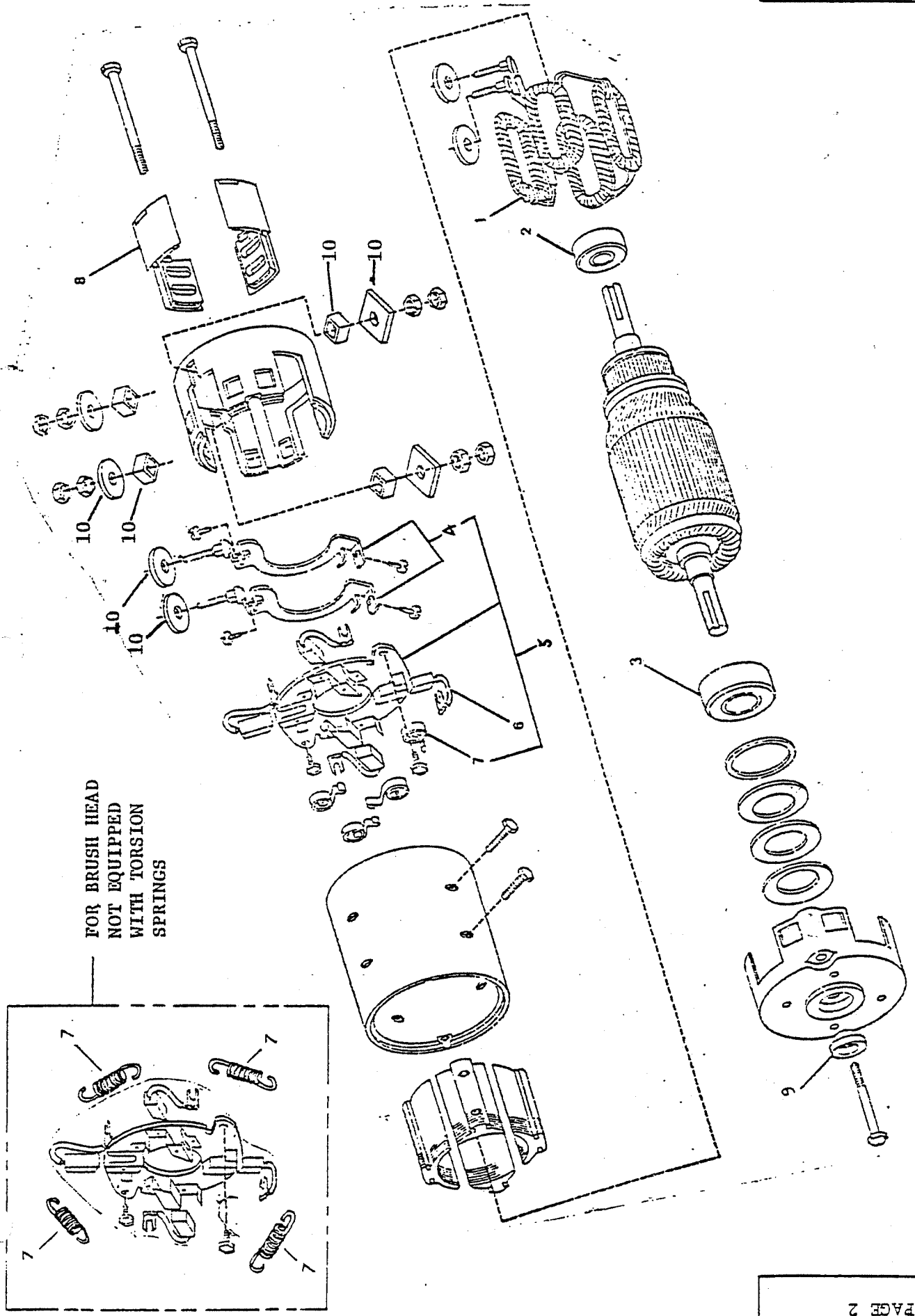

ELECTRIC MOTORS
REFER TO FIGURE 5M

For D.C. Motor replacement parts, IT IS NECESSARY TO INCLUDE COMPLETE MOTOR NAME PLATE DATA WITH THE ORDER.

FIG. I.D. NO.	T-D PART NO.	DESCRIPTION	QTY.
Replacement parts for G.E. Motor 5BC48JB503, 5BC48JB531, 5BC48JB550 and 5BC48JB582			
5M-1	70-201-00	Field Coil Set (not used on G.E. Motor 5BC48JB582)	1
5M-1	70-202-00	Field Coil Set (For G.E. Motor 5BC48JB582)	1
5M-2	80-200-00	Ball Bearing - Commutator End	1
5M-3	80-504-00	Ball Bearing - Pulley End	1
5M-4	70-195-00	Set of two armature terminal & brush pair connectors, <u>not used on motor 5BC48JB550 with suffix letter "C" or "D".</u> Two required per motor. (included in 70-188-00)	2
5M-4	70-196-00	Armature terminal & brush pair connector, <u>used only</u> with motor 5BC48JB550 with suffix letter "C" or "D". Two required per motor. (included in 70-184-00).	2
5M-5	70-184-00	Brush holder, without brushes, including brush springs, armature terminal & brush pair connectors. <u>Used only on motor 5BC48JB550 with suffix letter "C" or "D".</u>	1
5M-5	70-188-00	Brush holder, without brushes, including brush springs, armature terminal & brush pair connectors. <u>Not used on motor 5BC48JB550 with suffix letter "C" or "D".</u>	1
5M-6	70-101-00	Motor Brush	4
5M-7	85-412-00	Brush Spring, Torsion	4
5M-8	30-801-00	Brush Inspection Cover	4
5M-9	45-506-00	Oil Seal	1
5M-10	70-210-62	Motor Terminals Insulator Kit	1
Replacement parts for G.E. Motors 5BC48JB251 & 5BC48JB265			
5M-2	80-200-00	Ball Bearing, Commutator End	1
5M-3	80-504-00	Ball Bearing, Pulley End	1
5M-5	70-185-00	Brush Holder Assy.	1
5M-6	70-100-00	Motor Brush	4
5M-7	85-401-00	Brush Spring, Extension	4
5M-9	45-506-00	Oil Seal	1
Replacement Parts For G.E. Motor 5B6A8JB726			
	70-204-00	Field Coil Set	1
	80-209-00	Ball Bearing, Commutator End	1
	80-504-00	Ball Bearing, Pulley End	1
	70-172-00	Brush Holder Assy. <u>With</u> Brush Springs But <u>Without</u> Brushes	1
	85-412-00	Spring, Brush	4
	70-104-00	Armature Terminal & Brush Pair Connector	2
	45-506-00	Oil Seal	1

Brush Measurement Procedure For 726 Motor

With new brushes, A 1/16" drill rod can be inserted approximately .76" into brush measurement holes. Brushes should be replaced when rod can be inserted 1.56" into hole. This leaves approx. 1/8" allowable wear remaining.

FIG. I.D.

NO.	T-D PART NO.	DESCRIPTION	QTY.
Replacement Parts for G.E. Motor 5BC48JB67B & 5BC48JB114			
5M-2	80-205-00	Ball Bearing, Commutator End	1
5M-3	80-204-00	Ball Bearing, Pulley End	1
5M-6	70-100-00	Motor Brush Assy	4
5M-7	80-401-00	Brush Spring, Extension	4
Replacement Parts for T.D. Motor 388P3816 & Baldor 45-39W03, 45 39W16,45-39W19			
5M-2	80-200-00	Ball Bearing, Commutator End	1
5M-3	80-504-00	Ball Bearing, Pulley End	1
5M-5	70-187-00	Brush Head Assy, Complete with Brushes	1
5M-6	70-101-00	Motor Brush	4
5M-8	30-803-00	Brush Inspection Cover	4
5M-9	45-506-00	Oil Seal	1
Replacement Parts for G.E. Motor 5BCG56EA17			
5M-2	80-201-00	Ball Bearing, Commutator End	1
5M-3	80-504-00	Ball Bearing, Pulley End	1
5M-5	70-139-00	Brush Holder Assy	1
5M-6	70-101-00	Motor Brush Assy	4
5M-7	85-412-00	Brush Torsion Spring	4
Replacement Parts for G.E. Motor 5BC49JB122			
5M-2	80-200-00	Ball Bearing, Commutator End	1
5M-3	80-504-00	Ball Bearing, Pulley End	1
5M-4	70-185-00	Brush Holder	1
5M-6	70-100-00	Motor Brush	4
5M-7	85-401-00	Brush Extension Spring	4
5M-9	45-506-00	Oil Seal	1
Replacement Parts for G.E. Motor 5BC49JB305			
5M-1	70-203-00	Field Coil Set	1
5M-2	80-200-00	Ball Bearing, Commutator End	1
5M-3	80-504-00	Ball Bearing, Pulley End	1
5M-4	70-195-00	Armature Terminal to Brush	2
5M-5	70-188-00	Brush Holder assembly	1
5M-6	70-101-00	Motor Brush	4
5M-7	85-412-00	Brush Extension Spring	4
5M-8	30-802-00	Brush Inspection Cover	4
5M-9	45-506-00	Oil Seal	1
5M-10	70-210-62	Motor Terminals Insulator Kit	1

FIG. I.D. NO.	T-D PART NO.	DESCRIPTION	QTY.
Replacement Parts for Taylor-Dunn Motor 388P381A			
5M-2	80-204-00	Ball Bearing, Commutator End	1
5M-3	80-205-00	Ball Bearing, Pulley End	1
5M-5	*70-187-00	Brush Head Assy. Complete with Brushes *Not supplied as original equipment on <u>A</u> series motor but must be used as replacement part.	1
5M-6	*70-102-00	Motor Brush with Wire Hook *Replacement part for original <u>A</u> series motor <u>NOT</u> converted to new brush head assy. 70-187-00.	4
5M-6	70-101-00	Motor Brush for <u>A</u> series motor converted to new brush head 70-187-00.	4
5M-7	*85-413-00	Brush Torsion Spring *Replacement part for original <u>A</u> series motor <u>Not</u> converted to new brush head assy. 70-187-00.	4
5M-9	45-506-00	Oil Seal	1
5M-8	30-802-00	Brush Inspection Cover	1

MAINTENANCE PROCEDURES
HYDRAULIC BRAKE SYSTEM

Refer to Figure 6

Your hydraulic brake system consists of an automotive master cylinder operated by the brake foot pedal and control linkage.

Each rear wheel is fitted with a brake assembly and rugged brake drum. On 4 wheel brake models the front wheels are similarly equipped.

Refer to Maintenance Guide Section D and Lubrication Diagram Section E for proper lubrication and frequency of inspection.

Master cylinder fluid level should be checked monthly. Add fluid as needed to maintain level 3/8" to 1/2" from top of fill port. Use only approved hydraulic brake fluid.

A visual inspection of the hydraulic system is recommended on a monthly basis to detect any signs of leakage. Repairs should be made immediately if leakage is discovered.

A spongy action on brake pedal or a low engagement point on pedal usually indicates air entrapment or the need of shoe adjustment. Refer to Service and Adjustment Section J3 of this manual for proper procedures to follow.

SERVICE AND ADJUSTMENT
REFER TO FIGURE 6
HYDRAULIC BRAKE SYSTEM

The loss of brake pedal action may be due to a defective master cylinder. It can usually be detected by signs of fluid leakage at master cylinder or by the action of the brake pedal. When foot pedal pressure is applied you will feel the brakes engage, yet, the pedal will continue to travel downward. A ruptured hydraulic line or a defective wheel cylinder will produce the same action. You can determine the cause by the location of brake fluid leakage.

MASTER CYLINDER REPAIR OR REPLACE

1. Remove cotter pin, clevis pin, and remove push rod. (It will slide out of master cylinder socket).
2. Disconnect hydraulic line at cylinder (There will be 2 lines of 4 wheel brake system).
3. Remove 2 holding bolts and lift master cylinder out of chassis.
4. Cylinder should be thoroughly cleaned.
5. Remove boot and locking ring.
NOTE: Piston parts are under spring pressure, take care that they do not pop out when you remove lock ring.
6. Remove piston and cup assembly.
7. Inspect cylinder wall. If scoring or roughness is present it must be removed with a fine hone.
8. Taking care that all parts are kept clean, install new piston and cup assembly kit. A diagram is furnished with each kit. It is also recommended that parts are coated with a small amount of brake fluid prior to assembly.
9. Replace lock ring and boot.
10. Install cylinder in chassis in reverse order to which it was removed.
11. ADJUST push rod by loosening locknut and shortening or lengthening the rod so that when brake pedal is fully raised the push rod should be within 1/16" of contacting piston socket. A good way to be certain is to remove clevis pin. While lightly holding rod against socket (DO NOT PUSH HARD ENOUGH TO MOVE PISTON) observe the alignment of clevis and hole. When correct you will have to pull rod approximately 1/16" out of socket to insert clevis pin.
12. Tighten locknut and install cotter pin.

BLEED AIR FROM BRAKE SYSTEM

NOTE: Anytime that any part of the hydraulic system is disconnected or replaced, it is necessary to bleed air from system.

If fluid level is allowed to fall too low in master cylinder reservoir, air will be pumped into system. Consequently the system will have to be bled to remove air. To bleed air from system, follow procedure outlined next.

1. For best results brake shoes should be properly adjusted prior to bleeding system. (refer to Adjustment Section J3 of this manual).
2. Fill master cylinder to top with approved brake fluid or, if available, attach brake bleeder tank to master cylinder.
3. When using bleeder tank, loosen air bleeder valve (located at each wheel cylinder), one at a time, Allow fluid to flow until air pockets and bubbles stop and clear stream appears.
3. Alt. It is necessary to utilize 2 people to bleed brake system when bleeder tank is not available. One person will operate brake pedal and add fluid to master cylinder as needed. The other person will operate bleeder valves. While one person applies brake pedal pressure, loosen bleeder valve. Fluid and air will be forced out on the downward stroke of the pedal. Person operating pedal must hold it down at the end of its stroke while the other person closed bleeder valve. If pedal is raised while bleeder valve is open, air will be drawn back into the system. By coordinating the movements of the 2 people, air will be bled out of each downward stroke of the pedal. It is wise to refill master cylinder after every 3 or 4 strokes to insure against any air being drawn in because of the reservoir level being to low. Usually 2 to 4 strokes per wheel cylinder is sufficient to remove air from system.
4. Remove brake bleeder tank if used. Fill master cylinder 3/8" to 1/2" of top and replace cover.

REPLACING WHEEL CYLINDERS OR BRAKE SHOES

1. Remove wheel lugs, wheel and brake drum.
2. Unhook springs and remove brake shoes. (refer to diagram). Brake shoes should be replaced when lining is worn to rivet head.
3. To remove wheel cylinder, disconnect hydraulic line.
4. Remove 2 wheel cylinder bolts from backing plate and remove wheel cylinder.
5. If installing replacement kit, clean wheel cylinder thoroughly.
6. Remove dust caps and piston parts.
7. Examine cylinder walls. If scored or rough, remove with fine hone.
8. Install new kit assembly. Lubricate new parts with brake fluid.
9. Replace wheel cylinder and brake shoes in reverse order of removal.
10. Replace brake drum. (if brake drum is badly scored, replace with new one).
11. Replace wheel.
12. Bleed hydraulic System and Adjust Brake Shoes.

ADJUST BRAKE SHOES--REAR WHEEL BRAKES

1. Loosen both locknuts on eccentric adjusting studs (Refer to diagram).
2. Turn forward shoe adjustment stud away from wheel cylinder (as indicated by arrows in diagram) until heavy drag is felt while revolving wheel. (Wheel must be raised clear of floor).
3. Then back off by turning adjustment stud in opposite direction slightly until wheel is just free of drag.

4. Repeat procedure on rear brake shoe.
5. Tighten locknuts, being careful to hold stud with wrench so as not to disturb adjustment.
6. Depress brake pedal several times and check to be sure wheel still revolves free of drag and desired pedal travel is obtained.
7. If wheel drags, repeat adjustments as previously outlined, until satisfactory results are obtained.
8. If wheel (or wheels) are free of drag, but pedal has too much travel, check adjustments as previously outlined. If necessary, bleed hydraulic system.

ADJUST BRAKE SHOES--FRONT WHEEL BRAKES

Front wheel brake adjustment is identical to rear wheel adjustment with one exception.

The forward shoe and rear shoe are simultaneously adjusted by turning one adjusting stud.

This stud is located on the inboard side of the brake backing plate near the lower end of the brake shoes. Turning the stud clockwise (when viewed from the inside of the wheel) decreases the drum to shoe clearance, and turning it counter clockwise increases the clearance.

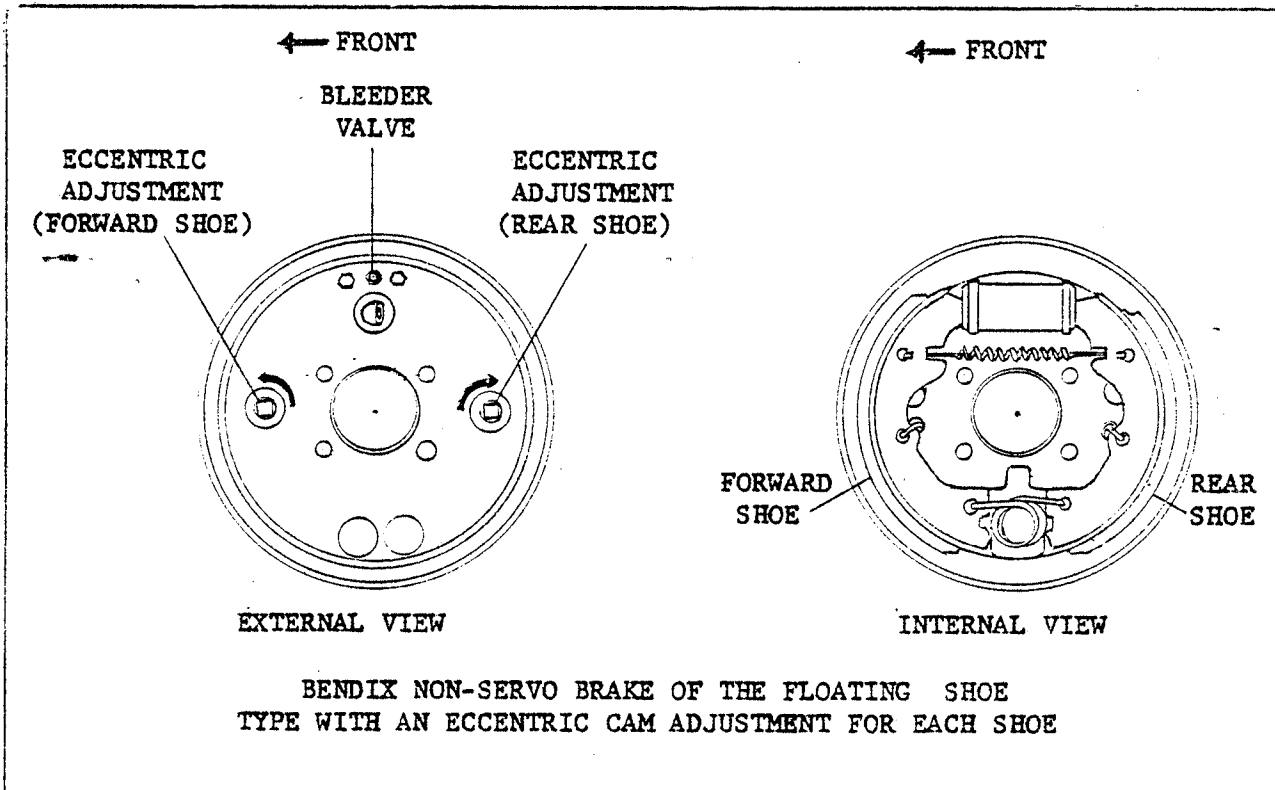

OPTIONAL FRONT WHEEL HYD. BRAKES

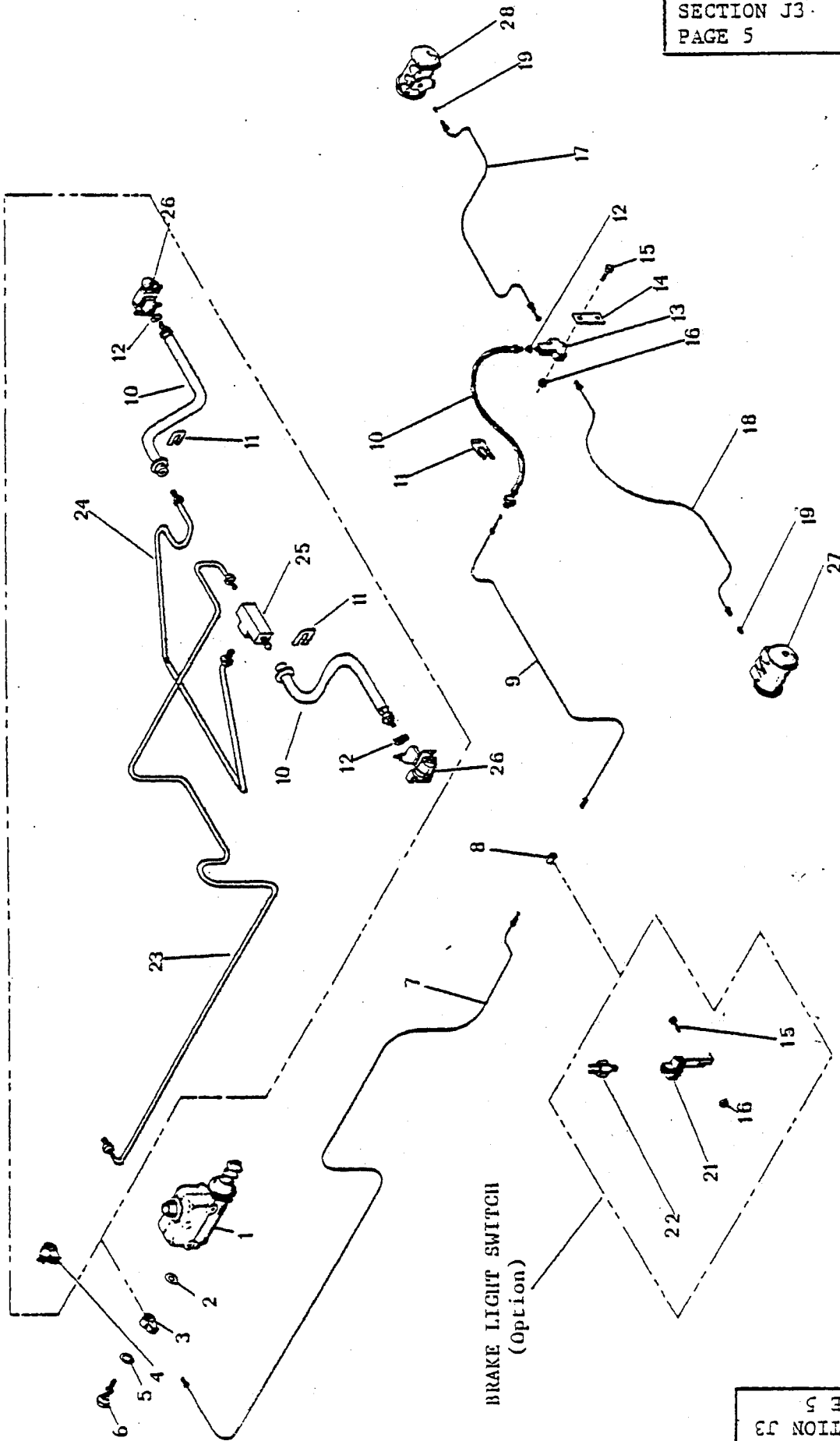

BRAKE LIGHT SWITCH
(Option)

SECTION J3
PAGE 5

SECTION J3
PAGE 5

NO.	DESCRIPTION	LENGTH	QUAN.	REVISED DATE	REVISION
<p>FIGURE 6 SECTION 05 HYDRAULIC BRAKE SYSTEM (2 AND 4 WHEEL)</p>					
<p>TAYLOR DUNN MFG. CO. 2114 West Ball Rd. Anaheim, Calif.</p>					
<p>NO. DESCRIPTION TOL. FRAC. † DEC. † SCALE DRAWN BY . L.M. DATE 10-23-78</p>					

FIGURE NO. 6
HYDRAULIC BRAKE SYSTEM (2 AND 4 WHEEL)

FIG. I.D. NO.	T-D PART NO.	DESCRIPTION	QTY REQ.
6-1	99-510-00	Master Cylinder	1
6-1	99-510-61	Repair Kit (Master Cylinder)	1
6-2	99-571-00	Washer (Copper Small Hole)	1
6-3	99-566-00	Fitting (3/16" Tube Single Outlet 2 Wheel Brakes)	1
6-4	99-565-00	Fitting (3/16" Tube Dual Outlet) 4 Wheel Brakes	1
6-5	99-572-00	Washer (Copper Large Hole)	1
6-6	99-579-00	Bolt (Master Cylinder Fitting Adaptor)	1
6-7	99-609-51	Formed Steel Brake Line (3/16" X 72")	1
6-8	99-575-00	Union (3/16" Tube)	1
6-9	99-608-51	Formed Steel Brake Line 3/16" X 60"	1
6-10	99-580-10	Assembly Brake Hose	2
6-11	99-576-00	Clip (Hose)	2
6-12	99-574-10	Spacer	2
6-13	99-563-00	Tee Fitting (3/16" Tube X 3/16" Tube X 3/8-24)	1
6-14	99-557-00	Bracket (Fitting Mount)	1
6-15	88-060-11	Hex Head Cap Screw 1/2" NC X 1"	2
6-16	88-069-87	Nut 1/2" NC Fastite	2
6-17	99-603-51	Formed Steel Brake Line 3/16" X 12"	1
6-18	99-605-51	Formed Steel Brake Line 3/16" X 30"	1
6-19	99-574-00	Spacer Adaptor For Rear Wheel Cylinder Inlet	2
6-21	99-591-00	Fitting, Side Tapped Tee, 3/16 Tube & 1/8 NPT	1
6-22	71-110-00	Switch, Brake Light (Hydraulic)	1
6-23	99-608-52	Formed Steel Brake Line 3/16" X 60	1
6-24	99-606-51	Formed Steel Brake Line 3/16" X 40	1
6-25	99-559-00	Tee Fitting 3/16" Tube X 3/8"-24 INU. X 3/16" Tube	1
6-26	99-501-00	Wheel Cylinder (Front Wheel)	2
6-27	99-506-98	Wheel Cylinder-Left Rear	1
6-27	99-506-99	Wheel Cylinder-Right Rear	1

MAINTENANCE PROCEDURES

REFER TO FIGURE 7

MECHANICAL CONTROL LINKAGE

The mechanical control linkage operates the various controls and mechanisms located throughout your vehicle.

The accelerator system consists of the operating pedal and pivot shaft assembly, the connecting rods and adjusters and the return spring. All wear points should be lubricated monthly for normal service. Refer to Maintenance Guide Section D and Lubrication Diagram Section E for proper application of lubricants.

The handbrake system consists of the hand operating lever, pivot shaft, connecting rod, and adjuster and the mechanical brake operating cable. (Note that on vehicles equipped with mechanical brakes only, this cable serves as the operating cable for the foot brake system as well).

The footbrake system consists of the foot pedal, pivot shaft, brake operating cable as mentioned above, the return spring, and the master cylinder and push rod assembly on vehicles equipped with hydraulic brakes.

The automatic deadman brake system consists of the pivoted seat assembly. The operating cable or rods. The brake apply spring, adjustable tension device and its connecting linkage.

All wear points should be lubricated monthly. Refer to Maintenance Guide Section D and Lubrication Diagram Section E for proper application of lubricants.

For service and adjustments refer to the following sections:

Section J2 - For hand brake and mechanical brake or "Deadman" brake service and adjustments.

Section J3 - For Master cylinder and push rod adjustments and service.

Section J6 - For accelerator service and adjustments.

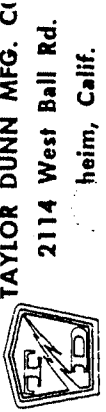

WI-248-20

Notes: Parts Shown in Dotted Lines Represent Their Alternate Location On 3 Wheel Models.

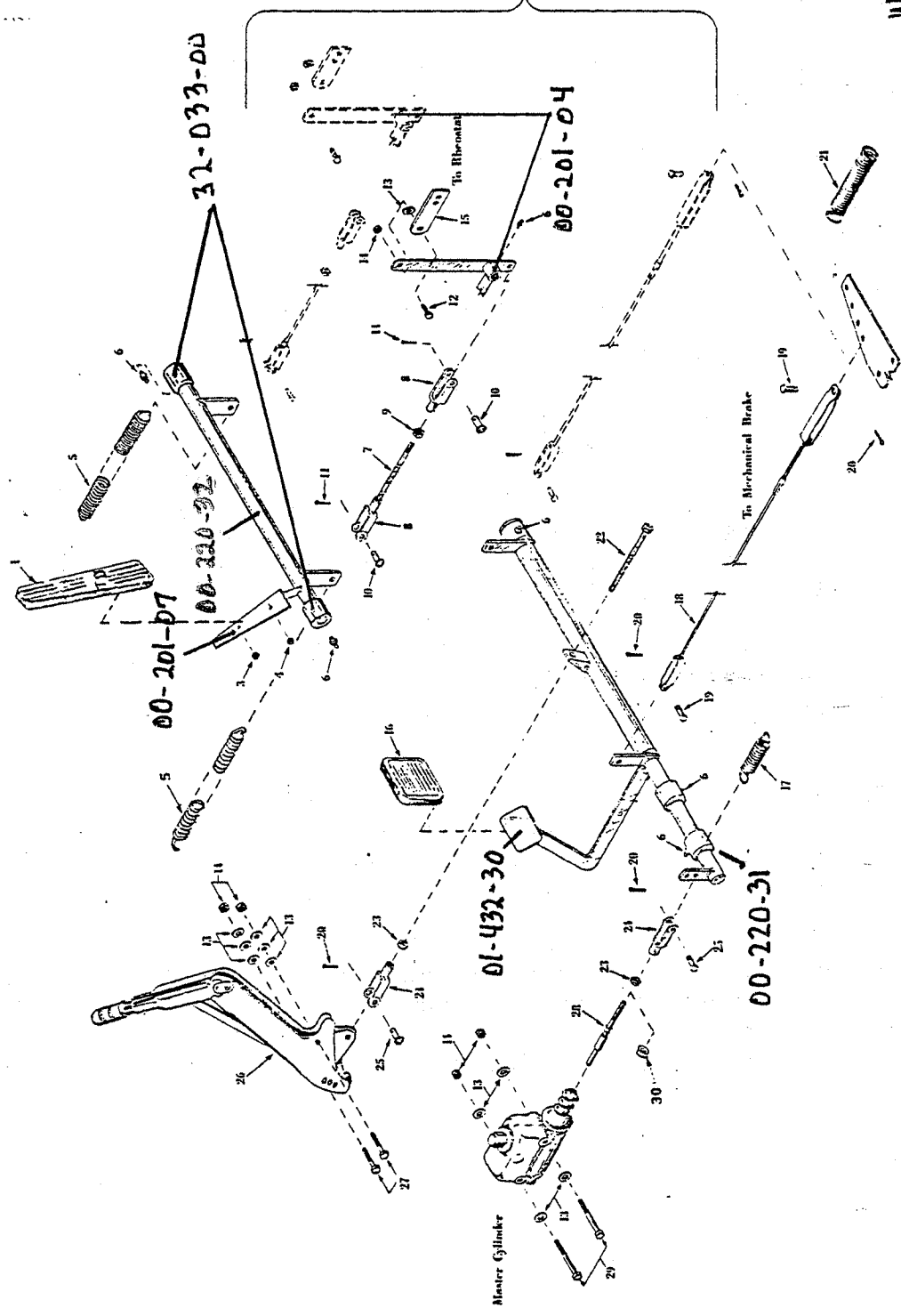

SECTION J4
PAGE 2

NO.	DESCRIPTION	LENGTH	QUAN.	REVISED DATE	REVISION
MECHANICAL CONTROL LINKAGE 3 & 4 WHEEL MODELS					
FIGURE 7 SECTION J4					
TOL. FRAC.	+	DEC.	+		
SCALE	NONE				
DRAWN BY	REA				
DATE	11-8-52				

MECHANICAL CONTROL LINKAGE
REFER TO FIGURE NO. 7

FIG. I.D. NO.	T-D PART NO.	DESCRIPTION	QTY. REQ.
7-1	98-254-00	Accelerator Pad (Aluminum)	1
7-2	88-025-08	Truss Head Machine Screw 8-32 x 5/8"	1
7-3	88-029-80	Nut 8-32 (Hex)	1
7-4	88-079-80	Nut 1/4" NF (Hex)	1
7-5	85-233-00	Spring - Extension 11/16" OD x 6 1/2" Free Length	2
7-6	87-071-00	Grease Fitting 3/16" Drive Type (Straight)	6
7-7	50-014-00	Accelerator Rod 5/16" x 11" Long	1
7-8	96-763-00	Cast Clevis 5/16"	2
7-9	88-099-80	Nut 5/16" NF (Hex)	2
7-10	96-773-00	Clevis Pin 5/16"	2
7-11	88-517-09	Cotter Pin 3/32" x 3/4"	2
7-12	88-100-11	Hex Head Cap Screw 3/8 x 1" NC	1
7-13	88-108-60	Washer 3/8" Flat	11
7-14	88-109-81	Lock Nut 3/8" NC (Hex)	5
7-15	61-834-00	J Hook Insulating Board	1
7-16	98-200-00	Rubber Brake Pedal Pad	1
7-17	85-250-00	Spring Extension 1-1/16" OD x 3-5/8" Free Length	1
7-18	96-821-00	Adjustable Cable Assembly (63 1/2" to 60 1/2")	1
7-19	96-771-00	Clevis Pin 3/8" x 3/4" (Face To Hole)	2
7-20	88-527-11	Cotter Pin 1/8" x 1"	4
7-21	85-270-00	Spring-Extension 1 1/2" OD x 4-3/8" Free Length	1
7-22	88-111-28	Hex Head Cap Screw 3/8" x 6" NF (H.T.)	1
7-23	88-119-80	3/8 NF Hex Head Nut	2
7-24	96-762-00	Cast Clevis 3/8"	2
7-25	96-772-00	Clevis Pin 3/8" x 1" (Face to Hole)	2
7-26	51-340-00	Hand Parking Brake Lever with Spacers	1
7-27	88-100-15	Hex Head Cap Screw 3/8" x 1-3/4" NC	2
7-28	50-009-00	Master Cylinder Push Rod 3/8" x 5-3/8"	1
7-29	88-101-20	Hex Head Cap Screw 3/8" x 3" NC	2
(Not Shown)	50-633-00	Strap, Accelerator - Connects Optional EV-1 Accelerator Control Pivot Bar To Accelerator Pedal Rod.	
7-30	17-104-00	Collar, 3/8" Shaft	1

MAINTENANCE PROCEDURES
FORWARD/REVERSE SWITCH

Refer to Figure 8

The forward/reverse switch on your vehicle serves the same purpose as does the transmission in your automobile. It should be treated with the same respect, for abusive treatment will not only shorten its life but will seriously effect the life of the motor, drive gears and differential.

DO NOT SHIFT POSITION OF SWITCH FROM FORWARD TO REVERSE OR VICE-VERSA WHILE VEHICLE IS IN MOTION. REFER TO CAUTION NOTE, SECTION B.

It will require very little maintenance if properly used. Every month check contact fingers and rotor contacts for cleanliness and to insure that they are making snug and even contact. If they show evidence of abnormal pitting or burning they should be replaced.

Refer to Service and Adjustment, Section J5, of this manual for replacement procedures.

It is recommended that an occasional small quantity of lubricant be placed on the cam and cam follower of the switch. Refer to Figure 8.

An occasional application of powdered graphite or similar key lock lubricant will keep your key and lock in good working order.

CAUTION: Before working on the Forward/Reverse Switch or any part of the vehicle electrical system, disconnect both main battery leads, place Forward/Reverse Switch in Neutral, remove switch key and apply parking brake.

SERVICE AND ADJUSTMENT
FORWARD-REVERSE SWITCH
REFER TO FIGURE 8

Caution: Whenever service work is to be conducted on the switch or any part of your vehicle wiring system, disconnect both main battery leads or unplug power leads on vehicles so equipped.

REMOVAL, DIS-ASSEMBLY AND RE-ASSEMBLY OF SWITCH

1. Remove handle screw in center of handle and then remove handle and spacer.
2. Remove 2 screws in center of face plate, this will release switch unit from frame. Then lift switch unit clear of frame noting that the end plate will be free to lift off of switch.
3. Remove cover.
4. If you wish to remove contact fingers or finger-boards at this time, then it will be necessary to follow steps 5-6-8 & 9. If you will only be servicing the rotor assembly it will not be necessary to remove wires.
5. Note position of wires and mark their respective locations to insure that they will be properly placed on re-assembly.
6. Remove 4 wires from switch terminals and slide out of switch housing.
7. Pull cam follower away from cam on rotor and lift rotor assembly from switch housing.
8. If you wish to replace finger-boards at this time, tap them out of their slots in the direction of the handle end of switch taking care to catch the wedges as they come free of the frame.
9. Install new finger board in the reverse manner outlined in step 8, noting that the long notch on end of board is located on handle end of switch. Tap wedges into place to lock finger boards to frame.
10. Inspect cam and spring. If necessary replace with new parts.
11. Remove nut on end of rotor shaft and dis-assemble spacers and rotor contacts. Note: it is very important to observe the position of each part as you remove it from rotor shaft to insure its proper re-assembly. The rotor contacts look similar but are actually a pair consisting of a left and a right contact.
12. Re-assemble rotor parts on rotor shaft in their proper order and lock into place by tightening $\frac{1}{2}$ " nut at end of shaft. Use care in tightening nut as undue strain could shear the locking ring on opposite end of shaft.
13. Install rotor assembly into frame moving cam follower enough to allow cam to set in position.
Note: It will ease the rotor installation if you will place it in neutral position. I.E., the contacts will be free from finger contacts and the low side of cam will engage cam follower.

14. Install wires onto their respective terminals and tighten securely.
15. Replace cover.
16. Replace end plate and slide switch unit back into place against face plate.
17. Replace 2 screws. It may be necessary to exert sufficient pressure and joggle switch unit into alignment with screw holes as cam spring tends to hold the switch out of position. A simple method to align the face plate and switch frame together, is to slip a medium size nail or ice pick into one hole through both pieces. Align second hole, insert screw, and tighten. Remove nail or ice pick from first hole and install screw and tighten.
18. Replace spacer and handle and tighten into position with center screw.

REPLACEMENT OF CONTACT FINGERS ONLY

1. Remove cover. (Note: on some vehicles it will be necessary to remove switch from mounting plate to gain access to cover.)
2. If you will be removing more than one finger at a time, it is recommended that you note the position of the wires and mark their respective locations.
3. Remove terminal nut and wire.
4. Remove nut holding finger to finger-board and remove finger.
5. Install new finger and replace nuts and wires in the reverse order to which they were removed.



TAYLOR DUNN MFG. CO.
2114 West Ball Rd.
Chaim, Calif.

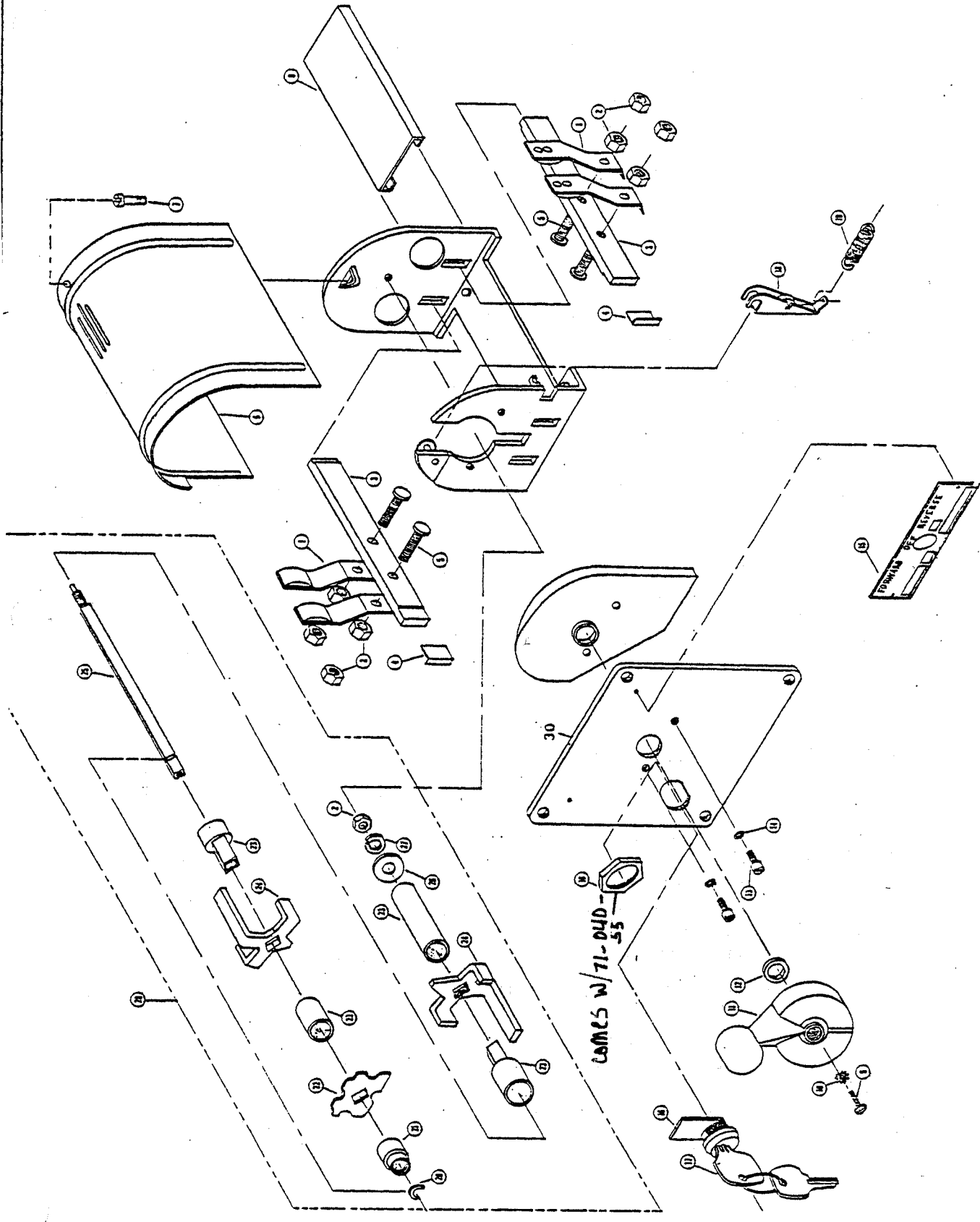

LENGTH	QUAN.	REVISED DATE	REVISION

FORWARD-REVERSE SW,
PART NO. 71-040-00

FIGURE 8
SECTION J5

SECTION J5
PAGE 4

NO.	DESCRIPTION
TOL. FRAC. ±	DEC. ±
SCALE	NONE
DRAWN BY	REA
DATE	9 3-69

FIGURE NO. 8
GROUP 8 FORWARD AND REVERSE SWITCH

FIG. I.D. NO.	T-D PART NO.	DESCRIPTION	QTY. REQ.
8-0	71-040-00	Forward & Reverse Switch Complete (4 Fingers)	1
8-1	71-040-60	Switch Finger - Silver Plated w/1/4" Hole	4
8-2	88-079-80	Nut 1/4" NF (Hex)	9
8-3	71-040-61	Finger Board w/1/4" Holes	2
8-4	71-040-69	Finger Board Wedge	2
8-5	71-040-71	Bolt-Finger Mounting (1/4" NF x 7/8" Spec)	4
8-6	71-040-65	Switch Cover	1
8-7	71-040-73	Cover Screw (10-32 x 1/2" Filister Head)	1
8-8	71-040-70	Rubber Insulator Strip	1
8-9	88-025-06	Screw 8-32 x 1/2" Truss Head	1
8-10	71-040-83	Washer 8-32 (External Star Lock)	1
8-11	71-040-62	Switch Handle - Metal (Red Color)	1
8-12	71-040-59	Spacer Washer	1
8-13	71-040-72	Face Stop Bolt (10-32 x 3/8 Spec.)	2
8-14	88-048-62	Lock Washer 10-32	2
8-15	94-305-00	Forward-Reverse Switchplate	1
8-16	71-040-55	Lock Assembly with 2 Keys	1
8-16	71-040-81	Tubular Lock Assembly with 2 Keys	1
8-17	71-040-74	Key Only (Give No. of Lock or Vehicle Ser. No.)	2
8-18	71-040-53	Cam	1
8-19	71-040-54	Spring (Cam)	1
8-20	71-040-75	Snap Ring - 1/4"	1
8-21	71-040-68	Bushing	1
8-22	71-040-67	Cam Index	1
8-23	71-040-66	Plastic Spacer Set (Sold Only As set of 4 PCS)	1 Set
8-24	71-040-58	Rotor Contacts (Set of 2-1 Right & 1 Left)	1 Set
8-25	71-040-64	Rotor Shaft (Only)	1
8-26	88-068-61	Washer SAE	1
8-27	88-068-62	Lock Washer 1/4"	1
8-28	71-040-52	Rotor Assembly	1
8-30	71-040-82	Face Plate	1
	71-040-20	Kit-Conversion to Six Finger Switch	1
<u>SWITCH EXTENSION HANDLE PARTS</u>			
8-9	71-040-80	Extension Rod - 8-32 x 6 1/2" Long	1
8-9	71-040-78	Extension Tube - 11/16 OD x 5 1/2" Long	1
8-11	71-040-77	Switch Position Indicator	1
	71-040-79	Bracket - Extension Support	1
	88-029-80	Nut 8-32 (Hex)	1

MAINTENANCE PROCEDURES
RHEOSTAT SPEED CONTROL

Refer to Figure 9

The rheostat, controls the speed of your vehicle through the use of coils of nichrome resistance wire. With this type of resistance control, you use approximately the same amount of power from batteries in low speed as you do in high speed. The flat copper bars and movable J-Hook are the major parts in the rheostat. With proper adjustment and lubrication the rheostat will give many months of trouble free use. It doesn't take much grease to do the job, but it should be done weekly. Monthly the space between bars should be cleaned with a piece of wood or plastic or steam cleaned if possible. When J-Hook is worn to 1/8" thickness, replace J-Hook and power bars.

Refer to Service and Adjustment SECTION J6 of this manual for proper adjustment and service procedures.

It is recommended that all terminal connections be checked and tightened at least once a month. If a terminal bolt or wire becomes loose, sufficient heat will be generated to cause permanent damage to the connection. Care should also be taken at each inspection to insure that proper contact is maintained between J-Hook and power bars.

J-Hook and accelerator linkage should work freely allowing return spring to always return J-Hook to neutral bar when accelerator is released.

Refer to Lubrication Diagram Section E for proper lubrication.

SERVICE AND ADJUSTMENT
RHEOSTAT SPEED CONTROL
REFER TO FIGURE 9

CAUTION: Before working on the Rheostat Speed Control Switch or any part of the vehicle electrical system, disconnect both main battery leads, place Forward/Reverse Switch in Neutral, remove switch key and apply parking brake.

ADJUSTMENT OF J-HOOK PRESSURE BAR

1. Adjust J-Hook pressure bar by disconnecting J-Hook from accelerator link and sliding J-Hook near the anchor bolt at neutral bar end. Anchor bolt is held in position by 2 nuts. Loosen 1 nut and adjust the other until J-Hook may be moved with a minimum of effort but not allowed to "jiggle" freely. At the opposite end of the pressure bar, adjust the spring pressure to maintain snug contact between J-Hook and power bars. Too much spring pressure will promote poor contact, causing bruning and pitting to occur. Re-connect operating arm to accelerator link and check operation of switch. J-Hook should slide smoothly with very little noise. If noticeable clicking noises occur as J-Hook passes over power bars, it is usually indicative of poor J-Hook alignment. If necessary, bend or twist connecting strap until J-Hook contacts power bars in a flat and smooth manner.

CAUTION: Every time adjustments are made to rheostat switch, always check the operation of the accelerator pedal. The J-Hook MUST return completely to neutral bar when pedal is released from any position. Lubricate as outlined in Section E.

ADJUSTMENT OF J-HOOK TRAVEL

1. Adjust rheostat J-Hook travel by depressing accelerator pedal to floor and checking alignment of J-Hook with the 5th power bar. J-Hook and 5th power bar should be in exact alignment with full contact. If J-Hook does not line up properly adjust accelerator control rod length by loosening lock nut and removing cotter pin and clevis pin. If J-Hook does not travel far enough onto the 5th power bar, turn clevis to lengthen rod sufficiently for correct alignment. Adjust clevis in the opposite direction, Shortening rod if J-Hook is traveling too far past the 5th power bar.

NOTE: Each 1/2 turn of clevis will move J-Hook position approximately 1/16".

REPLACEMENT OF J-HOOK

1. With power disconnected, remove 2 bolts attaching J-Hook to connecting strap.
2. Slide J-Hook to full on position and open pressure bar by pulling against spring pressure.
3. Roll J-Hook out from between pressure bar and power bars.
4. Replace J-Hook following reverse procedure.

REPLACEMENT OF RHEOSTAT SWITCH

1. Note location of wires connected to switch and mark accordingly, to insure their return to original location on re-assembly.
2. Remove wires at respective terminals.
3. Remove bolts connecting J-Hook insulator to operating link.
4. Remove 3 bolts holding switch to bracket and remove switch.
5. Replace switch in the reverse manner to which it was removed.
6. Check and adjust rheostat switch as outlined above.

REPLACEMENT OF POWER BARS

1. With power disconnected, remove terminal bolt and holding bolts.
2. Slide bar out of rheostat.
3. Clean switch thoroughly and install new bar.

NOTE: Power bars tend to wear at the same rate, except when 1 bar may become excessively burned because of poor contact. When replacing with new power bars, it is important that all bars be of the same thickness. Binding and sticking will occur when bars are not of uniform thickness.

It is recommended that power bars be replaced as a set rather than individually to avoid the above condition.

Minor high points may be removed with a file to produce smooth switching action.

4. Follow adjustment procedures previously outlined.

ADJUSTMENT OF DASHPOT ASSEMBLY

Refer to Section J4 and Figure 7.

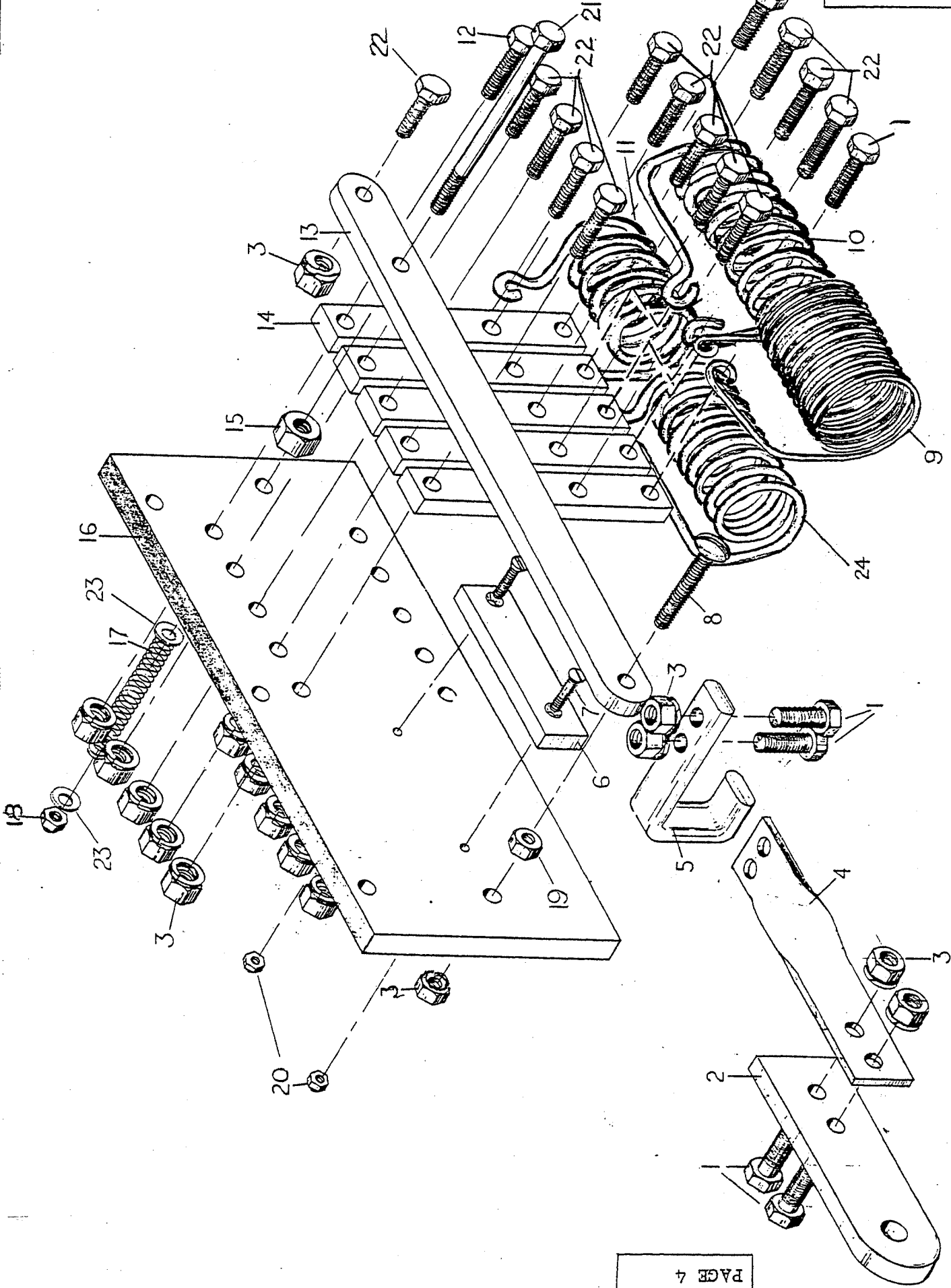

TAYLOR DUNN MFG. CO
2774 West Ball Rd.
Inglewood, Calif.

SPEED CONTROL RHEOSTAT
5 SPEED

FIGURE 9
SECTION J6

TOL. FRAC. ±	DEC. ±
SCALE	NONE
DRAWN BY	B. B.

FIGURE NO. 9
GROUP 9 RHEOSTAT 5 SPEED CONTROL

FIG. I.D. NO.	T-D PART NO.	DESCRIPTION	QTY. REQ.
9-0	61-832-10	Sliding Bar J-Hook Assembly	1
	61-837-15	Sliding Bar Rheostat Assembly with coils, less J-Hook Assembly	1
9-1	88-060-09	Hex Head Cap Screw 1/4" NC x 3/4"	4
9-2	61-834-00	Insulating Board	1
9-3	88-069-87	Fastite Nut 1/4" NC	21
9-4	61-833-00	J-Hook Twisted Strap (4-1/2" Long)	1
9-5	61-832-00	Sliding J-Hook Bar	1
9-6	61-835-15	Neutral Bar (5 Speed)	1
9-7	88-026-10	Flat Head Machine Screw 8-32 x 7/8"	2
9-8	88-065-14	Truss Head Machine Screw 1/4" NC x 1-1/2"	1
9-9	78-212-51	Resistor Coil (#9 Wire 10 Turns)	1
9-10	78-212-52	Resistor Coil (#6 Wire 9 Turns)	1
9-11	78-212-53	Resistor Coil (#5 Wire 6 Turns)	1
9-12	88-060-13	Hex Head Cap Screw (1/4" NC x 1-1/2") (Terminal Bolt)	1
9-13	61-836-00	Pressure Bar	1
9-14	61-831-00	Power Bar	5
9-15	88-109-80	Nut 3/8" NC (Hex)	1
9-16	61-837-00	Mounting Board	1
9-17	85-034-00	Spring-Compression 7/16" OD x 2"	1
9-18	88-069-81	1/4" NC Lock Nut	1
9-19	88-069-80	Nut 1/4" NC(Hex)	1
9-20	88-029-86	Flexlock Nut 8-32	2
9-21	88-060-22	Hex Head Cap Screw 1/4" NC x 3-1/2"	1
9-22	88-060-11	Hex Head Cap Screw 1/4" NC x 1"	13
9-23	88-068-60	Washer 1/4" Flat	2
9-24	78-212-62	Resistor Coil (#8 Wire 8 Turns)	1

MAINTENANCE PROCEDURES
GENERAL ELECTRICAL SYSTEM

Your electrical system has been installed with care, utilizing quality materials for safe trouble free service. Proper fuses have been located where necessary to prevent unsafe overloads and protect the wiring from being damaged from short circuits.

Little care will be required, except for an occasional visual inspection for loose connections or some unusual condition causing the insulation to be rubbed off on a wire.

Normal replacement parts such as light bulbs, fuses, flashers, etc., have been arranged for simple changing by plug in devices or conveniently located terminals.

CAUTION: A blown fuse is usually indicative of a short circuit or faulty device. Care should be exercised to remove the faulty condition before replacing fuse. DO NOT place larger capacity fuses or "jumpers" to overcome the condition as serious wiring damage can occur.

Refer to the following sections for more detailed information on the main power and electrical components:

- Section G - Wiring Diagram
- Section J2 - Motor
- Section J6 - Speed Control and Main Power Switching
- Section J8 - Batteries and Charger

Refer to the following page for a listing of electrical parts.

GENERAL ELECTRICAL PARTS

T-D Part NO.	DESCRIPTION	QTY. REQ.
71-070-00	Heavy Duty Toggle Switch 3 Pole/2 Throw (Hi-Lo Switch)	1
71-100-00	Light Switch	1
71-110-00	Brake Light Switch (Hydraulic Operated)	1
71-141-00	Turn Indicator Switch, 7 Wire	1
71-501-00	Horn Button	1
71-607-00	Switch Console	1
71-900-00	Flasher (12 Volt)	1
72-008-00	Chrome Headlight Fixture (Optional), 12V, w/5½" Sealed Beam Bulb	2
72-022-00	Stop and Taillight Fixture, 4" Rubber Mount (12 Volt)	2
72-051-00	Turn Light Fixture, (12 Volt) Amber, 4" Rubber Mount	2
73-000-00	Horn (12 Volt)	1
74-000-00	Hour Meter	1
74-050-00	Windshield Wiper Motor	1
74-051-00	Windshield Wiper Arm	1
74-052-00	Windshield Wiper Blade	1
74-050-61	Kit, Hardware only for windshield wiper mounting	1
75-126-11	Wire Harness, Control Only for EV-1A SCR System	1
75-013-00	Wiring Harness for Switch Console Including Light and Horn	1
75-127-11	Wire Harness, Power Only, for EV-1A SCR System	1
75-114-11	Wiring Harness for Turn Signal and Stop Light	1
75-204-00	Wire #4, Black (Per Foot)	
75-208-00	Wire #8, Black (Per Foot)	
75-218-00	Wire #16, Black (Per Foot)	
75-404-53	Terminal Lug #4 Wire ½" Hole	
75-404-54	Terminal Lug #4 Wire 5/16" Hole	
75-408-52	Terminal Lug #8 Wire 3/16" Hole	
75-408-53	Terminal Lug #8 Wire ½" Hole	
75-408-54	Terminal Lug #8 Wire 5/16" Hole	
75-418-51	Terminal Lug #16 Wire #6 Hole	
75-418-52	Terminal Lug #16 Wire 3/16" Hole	
75-418-53	Terminal Lug #16 Wire ½" Hole	
75-418-54	Terminal Lug #16 Wire 5/16" Hole	
75-420-00	Terminal, #16 Wire (For Hydraulic Stop Light Switch)	2
75-421-00	Terminal, #16 Wire (For Mechanical Stop Light Switch)	2
75-424-00	Terminal, #16 Wire (For Horn Connection)	2
76-352-00	Receptacle - Flasher - Cole Hearsee #3029	1
78-010-00	Secondary Circuit Fuse Holder (Inline) 20 to 30 Amp	1
74-009-00	Indicator, Charge, 36 Volt	1
74-009-10	Indicator, Charge, 24 Volt	1

MAINTENANCE PROCEDURES
BATTERIES

WARNING: Lead acid batteries continuously emit highly explosive gases. Flame or sparks must be kept away from the batteries at all times.

This emission is greatly increased during the charging process. Any area in which charging batteries are confined must be well ventilated, and flame or sparks must be kept out of the charging area and away from ventilator openings. DO NOT disturb battery connections while batteries are being charged.

The lead acid battery (or batteries) will furnish all power required by your vehicle. Two types are generally employed. The electric vehicle type battery pack, commonly used, can be expected to have a life of approximately 2 years, or 350 to 400 cycles. One cycle is the discharging and charging of the battery within proper limits. The heavy duty industrial type of battery has a life of approximately 7-1/2 years, or 1800 cycles, with appropriate use and care.

It cannot be over emphasized how important good maintenance procedures and careful care of your batteries will affect their useful life. It is therefore recommended that a comprehensive maintenance program be established and adhered to throughout the life of your vehicle. A 5 point program is outlined below to assist you in understanding and establishing good battery care.

1. CORRECT CHARGING

Poor charging practices are responsible for more short battery life than any one other item. The charging equipment must be properly maintained and adjusted to give a charge which the battery will accept with maximum efficiency. Two things are involved in correct charging. These are the charging rate in amperes and the termination of the charge at the correct time. No amount of overcharging will increase the battery capacity or raise the specific gravity above its full charged condition.

Overcharging will reduce battery life. Undercharging will cause poor vehicle performance, and shorten the life of all electrical components, including the batteries. Refer to Service Adjustment, Section J8, for proper methods to determine charge condition.

2. DISCHARGING - CAPACITY

Batteries are commonly rated in ampere hours at the six hour discharge rate to final voltage of 1.75 per cell. They will deliver additional capacity in an emergency, but should not be required to do so regularly. The best way to avoid discharging is to prepare a rigid schedule for charging batteries which will insure against their being discharged beyond the limits of their capability.

3. WATERING

Water must be replaced from time to time. The frequency and quantity depends upon the watering space above the plates and the amount of gassing which the battery does on charge. Only approved or distilled water should be added to the battery. Water should be added after hydrometer or voltmeter readings have been taken. The liquid level within the battery raises as the gassing occurs. Thus filling after charging minimizes over-filling. However, the water level should cover the plates prior to charging.

MAINTENANCE PROCEDURES
BATTERIES

4. CLEANING

Batteries pick up various kinds of dirt and dust, depending on their surroundings and the type of service they are subject to. This is usually dry dirt, which can readily be blown off with low pressure air or brushed off. However, if cells are overfilled and electrolyte collects on the covers, the top of the battery becomes wet and stays wet, since the acid in the electrolyte does not evaporate. This moist surface in combination with certain kinds of dirt becomes electrically conductive and permits stray currents to flow externally over the top of the battery. These currents cause corrosion of cell posts, nuts, connectors and steel trays, which eventually become troublesome and expensive to repair.

When wet dirt accumulates on top of the battery, remove it by washing the battery with a strong solution of baking soda and hot water (1 lb. of soda to 1/2 gallon of water). A convenient brush to use is one having flexible bristles like an old paint brush. Continue the application of the soda solution until all fizzing stops, which indicates that the acid has been neutralized. Then rinse thoroughly with clear water.

Wet covers can be indication of overfilling, leaky seals at posts and covers or of excessive gassing during charge. When observed the cause should be determined and the abusive conditions corrected.

5. RECORDS

A battery record system is recommended for all vehicles. It is considered essential for large operations, and where minimum battery operating cost is desired. A properly supervised record system can be made to detect and call attention to such operating irregularities as:

- a. Overcharging
- b. Undercharging
- c. Overdischarging
- d. Excessive Water Consumption
- e. Cleanliness
- f. Worn out Batteries
- g. Excessive Current Consumption on Trucks

It is not advisable to allow a battery to stand for a long period of time in a low state of charge. Doing so subjects the battery to excessive plate erosion and in cold climate conditions the electrolyte will freeze at a much higher temperature. For example, a fully charged battery will not freeze at temperatures near 60° below zero. Yet a battery in a very low state of charge may freeze at temperatures around 10° to 15° above zero.

A battery not in use maintains small amounts of chemical action which slowly tends to dissipate the charged condition. It is wise to re-charge a battery not in use every 1 to 2 months. If possible store the battery in a cool place, as the self discharge rate is increased with warmer temperatures.

Battery No.	Date			Date			Date			Date			
	Cell No.	Water OK or Low	Gravity Before Charge	Gravity After Charge	Water OK or Low	Gravity Before Charge	Gravity After Charge	Water OK or Low	Gravity Before Charge	Gravity After Charge	Water OK or Low	Gravity Before Charge	Gravity After Charge
1	1												
	2												
	3												
2	1												
	2												
	3												
3	1												
	2												
	3												
4	1												
	2												
	3												
5	1												
	2												
	3												
6	1												
	2												
	3												

- CAUTION: Batteries emit explosive gases. During normal operation the concentration of these gases is rarely sufficient to be considered dangerous unless flame or sparks occur in the battery compartment close to the vent holes in the battery caps. It is important that this not be allowed to occur at anytime. During the charging process, emissions are greatly increased. Any area in which charging batteries are confined must be well ventilated, and flame, sparks, or lighted cigarettes must be kept out of the charging area and away from ventilator openings associated with the charging area. Battery connections must not be disturbed while batteries are being charged.
- Do not fill an uncharged battery. Bring water level up to just cover the plates, and complete filling after battery is fully charged. Use distilled water. Fill only to level indicated on battery.
- Batteries which require unusually frequent watering may indicate overcharging. Review charging practices and/or adjustment of transformer taps in charger.
- Gravity should be kept between 1175 (30% charged) and 1260 (100% charged), and gravity readings of all cells should be within 10 point range. When they are not, an equalizing charge should be applied. Refer to information under "Charging Time Chart" in Charger Handbook.
- Periodically check for loose terminal posts or loose connections to terminal posts, but not while batteries are being charged.
- Keep tops of batteries clean, and free of moisture, grease, and acid films. Any of these can cause current leakage.
- Keep weekly (or oftener) record as shown in above sample chart, for a new vehicle or when charging results seem unsatisfactory, until satisfactory charging continues for a four week period, then keep record on a monthly basis.

BATTERIES AND CHARGER

T-D PART NO.	DESCRIPTION	QTY. REQ.
74-005-00	Charger Indicator (12 Volt - Push to Test)	1
75-231-00	Battery Jumper #6 Wire (10 $\frac{1}{4}$ " Long)	5
75-234-00	Battery Jumper #6 Wire (18 $\frac{1}{4}$ " Long)	1
75-240-00	3 Prong Plug and Cord (For Lift-Out and Roll-Out Battery Boxes)	1
75-241-00	3 Prong Receptacle for Plug and Cord	1
76-002-00	Charging Plug, 30 Amp, 3 Prong	1
76-012-00	Charging Receptacle, 30 Amp, 3 Prong	1
76-020-00	Charging Receptacle and Plug, Anderson Type SB #6313 175 AMP	1 or 3
77-031-00	6 Volt, 190 A.H. Battery	6
77-042-00	6 Volt, 217 A.H. Battery	6
77-048-00	6 Volt, 250 A.H. Battery	6
77-200-00	Hydrometer	1
77-201-00	Battery Filler	1
77-903-00	Battery Hold Down Stop (Roll-Out Battery Box) Model B	1 or 2
77-904-00	Battery Hold Down Channel (Roll-Out Battery Box) Model B	1 or 2
77-965-00	Battery Box Dolly (For Roll-Out Battery Box) Model B	1 or 2
77-969-00	Battery Box Only (Lift Out for 250 A.H. Batteries) Model B	1 or 2
77-970-00	Battery Box Only (Roll-Out for 170 A.H., 217 A.H. and 250 A.H.) Model B	1 or 2
79-320-00	Charger, 36 Volt, 20 Amp, Type A (Portable) 115 Volt	
79-333-00	Charger, 36 Volt, 30 Amp, Type T (Portable) 115 Volt	
79-345-00	Charger, 36 Volt, 45 Amp (Portable) 115 Volt	
79-355-00	Charger, 36 Volt, 50 Amp (Industrial) 115/230 Volt	
79-375-00	Charger, 36 Volt, 75 Amp (Industrial) 230/460 Volt	
79-337-00	Charger, 36 Volt, 30 Amp, Type T, 115 Volt, Built in with Seperate Control Console	1

PART IDENTIFICATION
SERIES "A" & "T" CHARGERS

EXPLODED DIAGRAM

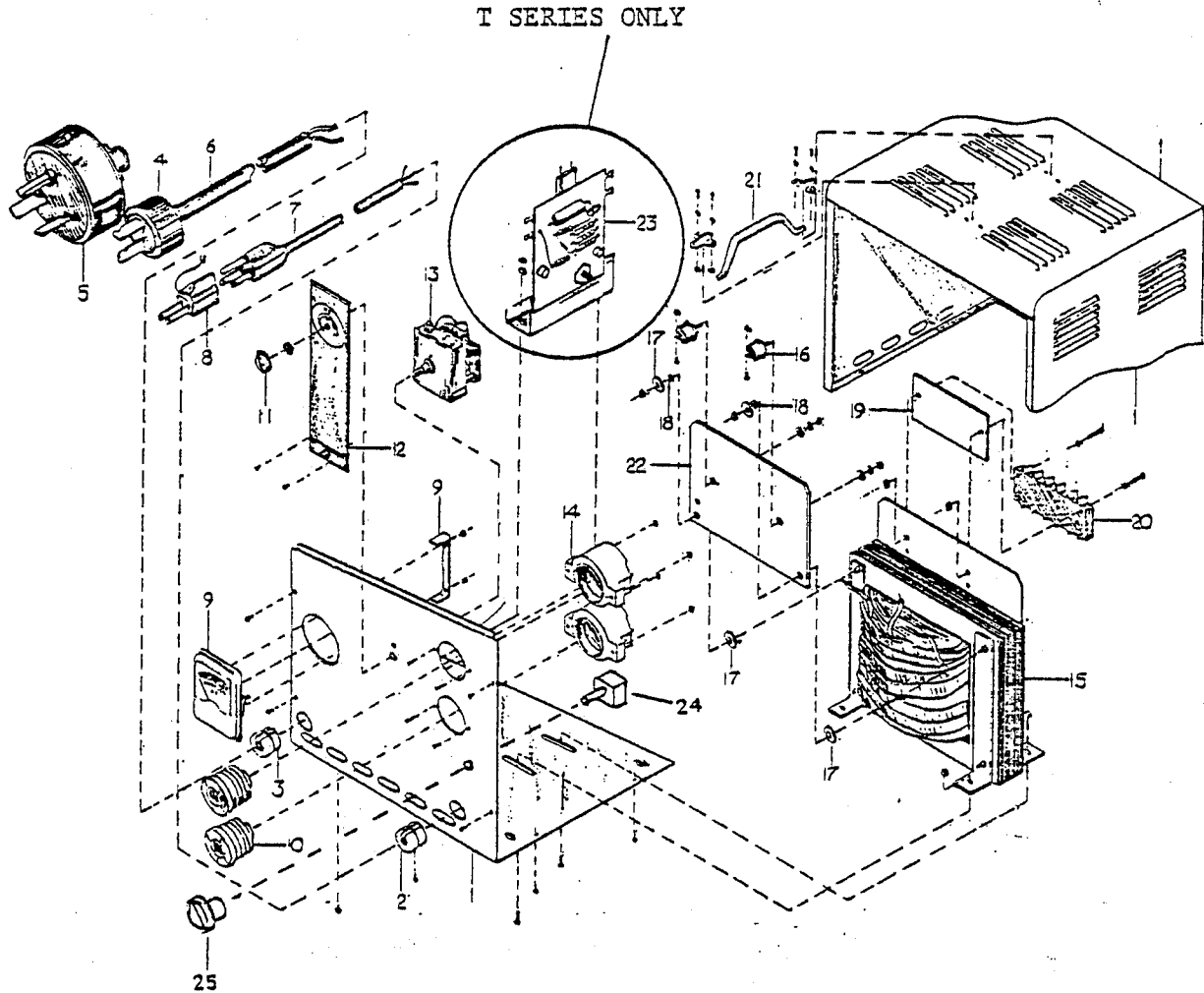

Portable Cabinet Shown.

I.D. Numbers of Internal Components are Identical for Portable and Built In Charger.

The final charge rate on a charged battery will be approximately 6 to 10 amperes depending on the rating of the charger. A shorter recharge time is achieved by using this method. Protection from overcharging is provided by the voltage sensing device.

INSTALLATION

Portable models may be set on any suitable working surface so that there is access to the control panel. There should be at least six inches of clearance on each side and two inches on the top to allow free flow of air for cooling. Do not expose the charger to rain or other adverse weather conditions. There must be a separately fused, three-wire, single phase, 115 volt, 15 ampere power receptacle within reach of the A-C input cord of the charger. If the A-C input voltage at your location varies from the nominal 115 volts, it will be necessary to adjust the charger for proper operation. A Low-Med-High switch on the charger is designed to make the necessary adjustment convenient. This switch is located on the front panel of all portable models and on the built-in models with separate control console.

The "Med." setting is designed for those locations where the voltage is between 113 and 120 volts. If your input voltage is between 121 and 128 volts, set the switch in the "Low" position. This will reduce the output voltage to compensate for the high input voltage. If the input voltage at your location is between 105 and 112 volts, set the switch in the "High" position. This will raise the output voltage to compensate for low input voltage. For greater accuracy, the input voltage should be measured during the time of day when the battery chargers are normally in use.

If the output current as shown on the meter exceeds the rated output of the charger, set the switch to the next lowest position to avoid damage. Once set, it should not be necessary to change the switch position as long as the charger is used at the same location.

OPERATING INSTRUCTIONS

1. Verify that the output fuses are fully tightened.
2. Connect the D-C plug to the battery receptacle. Portable chargers are furnished with a polarized D-C plug that mates with a corresponding polarized receptacle in the vehicle to prevent improper connections to the battery. Built-in models are permanently connected to the batteries.
3. Connect the A-C plug to a suitable, grounded receptacle.
A Series - Determine the minimum charging time (see CHARGING TIME CHART). Turn the charger on by setting the timer knob to the desired charging time.
T Series - Turn the charger on by setting the timer knob to "START" position (4 hours). The voltage sensing unit will automatically start the timer when the battery reaches 80% of full charge.
4. Verify that the output meter indicates a charging current. If there is no charging current, see TROUBLE SHOOTING section. Never let the charger charge higher than its rated output. If the charger is charging too high, check the batteries to be sure there are no defective cells or short circuits. See the instructions, concerning tap switch setting under INSTALLATION section.

5. The timer control will turn off the charger (positive turn off feature) at the completion of the charge.
6. Disconnect the battery from the charger. On built-in models, disconnect the A-C cord.
7. Using a hydrometer, verify that the battery is properly charged.

CHARGING TIME CHART (A SERIES)

The following chart provides useful information for determining the minimum charging time needed to restore a battery to a full charge condition. In addition to normal charging, the cells of the batteries should be equalized twice each month. This is done by charging the batteries an additional seven (7) hours after a normal charge cycle. The current indications of the ammeter must be low during cell equalization.

<u>Specific Gravity Reading</u>	<u>Condition of Battery</u>	<u>Hours Needed to Charge</u>
1100	fully discharged	12
1125	10% charged	10
1150	20% charged	8
1175	30% charged	7
1200	60% charged	4
1225	75% charged	2
1250	95% charged	1/2
1260	fully charged	0

TROUBLE SHOOTING & REPAIR INSTRUCTIONS

LOW OR NO CHARGING CURRENT

1. Using a voltmeter, verify that the battery being charged has no open or dead cells. Check jumper cables between batteries for tight and clean connections, and also verify that the battery is not already fully charged.
2. Check the output fuses of the charger to make sure they are not loose or "blown".
3. Verify that the A-C receptacle has power by plugging in an electrical appliance. Using a voltmeter, check A-C input voltage at the receptacle. Taps are provided inside back panel of charger to adjust for input voltages from 105 to 125. Verify that charger is connected for correct voltage.
4. Turn the charger ON and verify that the transformer hums. If no hum is heard, proceed with step 4.1. If a hum exists, go to step 5.
 - 4.1 Remove A-C plug from power source.
 - 4.2 Remove the cabinet cover (1) to gain access to the interior of the charger.
 - 4.3 With the timer switch OFF, check for continuity between the two primary input leads of the transformer. If no continuity is found, replace the transformer. If continuity is found, proceed as follows:
 - 4.4 With the timer switch ON, check for continuity across the switch. On "T" Series chargers there are two switches - check both. If switch is open with the timer ON, replace the timer assembly.
 - 4.5 If all of the above checks indicate continuity, but the transformer does not hum, check for loose or broken leads between the A-C plug, the timer assembly and the tap switch or terminal board.

5. If the transformer hums, proceed as follows:
 - 5.1 Remove A-C plug from power source.
 - 5.2 Check the two output fuses to insure they are good. Inspect the fuse holder for damage or a blackened appearance. (If the fuse holder is blackened, it indicates oxidation and should be replaced).
 - 5.3 Remove both output fuses. Check for continuity from the output side of both fuse holders to the positive side of the D-C plug, connecting continuity indicator first in one direction and continuity in the other. Continuity in both directions or no continuity in either direction indicates a bad diode. Replace the diode connected to that fuse holder.
 - 5.4 Check for continuity between the input side of one fuse holder and the input side of the other. If no continuity exists, the transformer secondary is open. Replace transformer.
 - 5.5 Check for continuity across the two terminals of the meter. If no continuity exists, the meter is open. Replace meter.
 - 5.6 If all indications to this point are normal, test the entire D-C output circuitry for continuity by progressing from the positive D-C output prong to the negative D-C output prong in incremental test sections, checking each connection for open circuits and poor conditions.

A-C LINE FUSES BLOW

6. With unit unplugged and timer turned ON, check for continuity between each input prong of the A-C plug and the ground prong. If continuity is found between either input prong and ground, a short circuit exists and must be found and removed. If all indications are open and the A-C fuses are of sufficient rating for the charger, a shorted transformer is the most probable cause of this problem. Replace transformer.

OUTPUT FUSES BLOW

7. Verify that the circuit under charge is not shorted by disconnecting the charger and operating it disconnected.
8. If output fuses continue to blow, test the charger as per steps 5.1 through 5.6.

TIMER DOES NOT TURN UNIT OFF

9. Unplug charger. Check continuity of timer motor. If open, replace timer. If not, check timer switch contacts. If timer assembly is not defective, adjust Voltage Sensing Unit as per instructions in next paragraph ("T" Series only).

VOLTAGE SENSING UNIT ADJUSTMENT PROCEDURE ("T" Series)

NOTE: A D-C voltmeter with the appropriate voltage range is required to perform the following adjustment.

10. The unit is assembled on a small panel inside the charger cabinet (see item 23, exploded diagram). Each unit has been carefully adjusted at the factory.

To actuate at the proper voltage; however, if it is desired to change the actuation voltage point, the following procedure should be followed:

- 10.1 Connect the charger to a battery which is known to be fully charged.
- 10.2 Observing polarity, connect the voltmeter across the battery terminals.
- 10.3 Turn the charger ON. The voltage across the battery, as indicated by the voltmeter, will rise slowly. When the proper voltage (dependent upon the number of cells) is reached, the small relay in the voltage sensing unit will actuate. This can be detected since it generates an audible click.

NOTE: The Voltage Sensing Unit should be set for 2.37 volts per cell. On a 24 volt system, the Voltage Sensing Unit should actuate at 28.4 volts. On a 36 volt system, the unit should actuate at 42.7 volts.

- 10.4 Turn the adjustment shaft on the voltage Sensing Unit clockwise to raise the actuating voltage and counter-clockwise to lower the actuating voltage.
- 10.5 Turn the charger ON and OFF, as necessary, to raise and lower battery voltage, while repeating steps 10.3 and 10.4 until the desired actuation point is achieved.

IMPORTANT FACTS ON BATTERIES AND CHARGERS

To determine whether or not a battery is properly charged, a measuring device known as a hydrometer is used. A hydrometer measures the specific gravity of a liquid and a battery hydrometer is graduated to measure the specific gravity of battery electrolyte. The electrolyte in your battery becomes heavier as it is charged, therefore, a higher specific gravity reading indicates a higher charge condition of your battery. The specific gravity reading will range from 1100 for a completely discharged battery to 1260 for a fully charged battery. No amount of overcharging will raise the specific gravity above 1260 on the electric vehicle type of battery. Both overcharging and undercharging can cause a premature failure of a battery. Overcharging destroys the positive plates. Consistent undercharging causes a buckling of the plates.

Do not discard a good battery as being defective because its specific gravity does not show an increase immediately upon applying a charge. Many good batteries require a charging period as long as three hours before they show any increase in the specific gravity. Do not charge a battery if the electrolyte temperature could rise above 120 degrees F. This could damage both battery and charger. As a rule of thumb, the electrolyte temperature during normal charging will rise about 25 degrees above the temperature in the charging area.

Failure to keep the battery electrolyte to the proper level will result in a crumbling (abnormal sulfation) of the plates and cause failure of the battery. Distilled water must be added to the battery regularly to make up for the loss due to evaporation. Prior to charging, the electrolyte level should cover the battery plates. Fill the battery to the proper level only after it has been fully charged.

WARNING - HAZARD OF EXPLOSIVE GAS MIXTURE

Batteries being charged or discharged will give off hydrogen gas. If this gas is concentrated it can cause an explosion. Concentrations of gas may remain for several hours if ventilation is not provided. Do Not have any fire in the vicinity and do not tamper with circuits that might cause sparking while charging or discharging batteries.

INSPECTION OF BATTERIES AND ASSOCIATED CIRCUITS

An inspection of batteries and associated circuits is required to assure that the batteries are being properly charged. For this inspection we recommend the use of a hydrometer and a continuity tester.

1. Verify that all connections within the unit to be charged are clean and right.
2. Check each battery for loose terminal posts.
3. Test for continuity between all battery terminals and the charging receptacle.
4. Verify that the top of each battery is free of moisture, grease and acid film, which may cause terminal corrosion and current leakage.
5. After the battery has been recharged, test each individual cell in each battery with the hydrometer to verify that all specific gravity readings are within 10 points of each other.
6. Using the hydrometer, pull out acid from a cell and then vigorously expel the acid back into the cell to cause a violent stirring action. Immediately draw out another sample of acid and visually inspect it to see if it contains a brownish sediment (indicates positive plates are deteriorated).
7. When testing battery condition with hydrometer, always return electrolyte solution to the same cell from which it was removed. DO NOT MIX electrolyte from one cell to another.

CIRCUIT DIAGRAMS

SERIES "A" & "T" CHARGERS

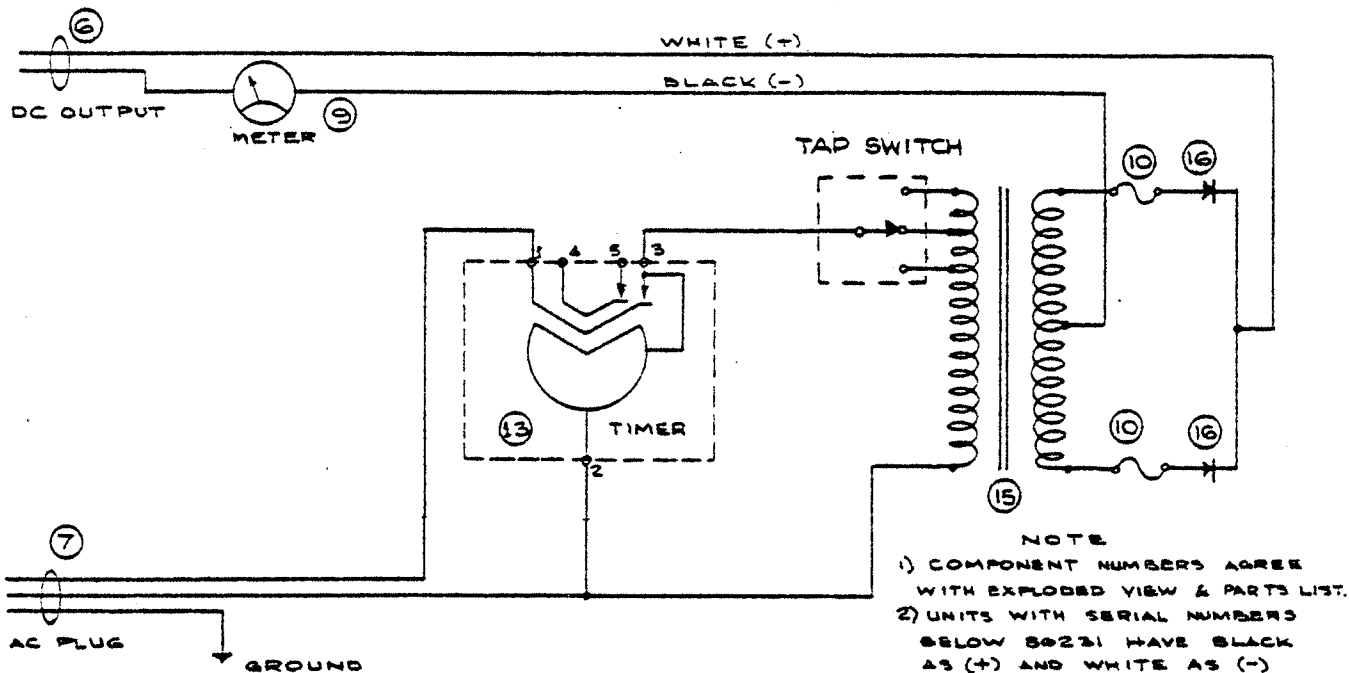

CHRISTIE SERIES "A" BATTERY CHARGERS

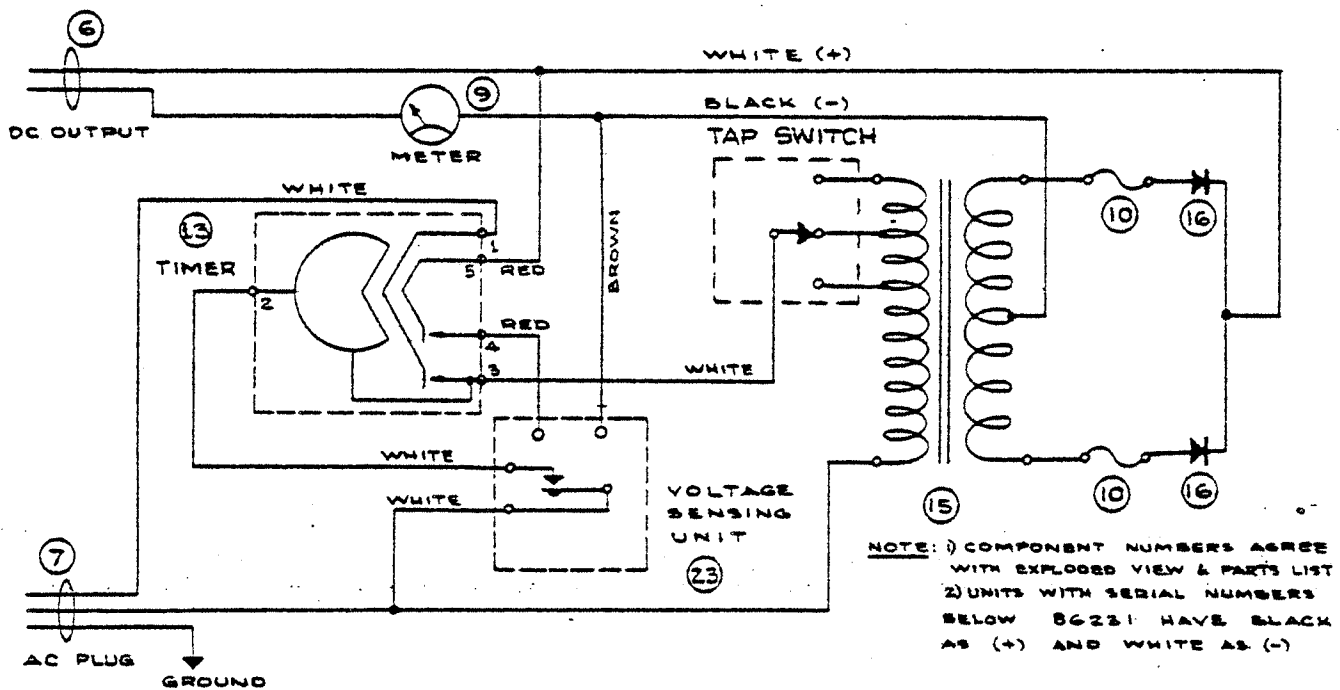

CHRISTIE SERIES "T" BATTERY CHARGERS

PART IDENTIFICATION
SERIES "A" & "T" CHARGERS

EXPLODED DIAGRAM

T SERIES ONLY

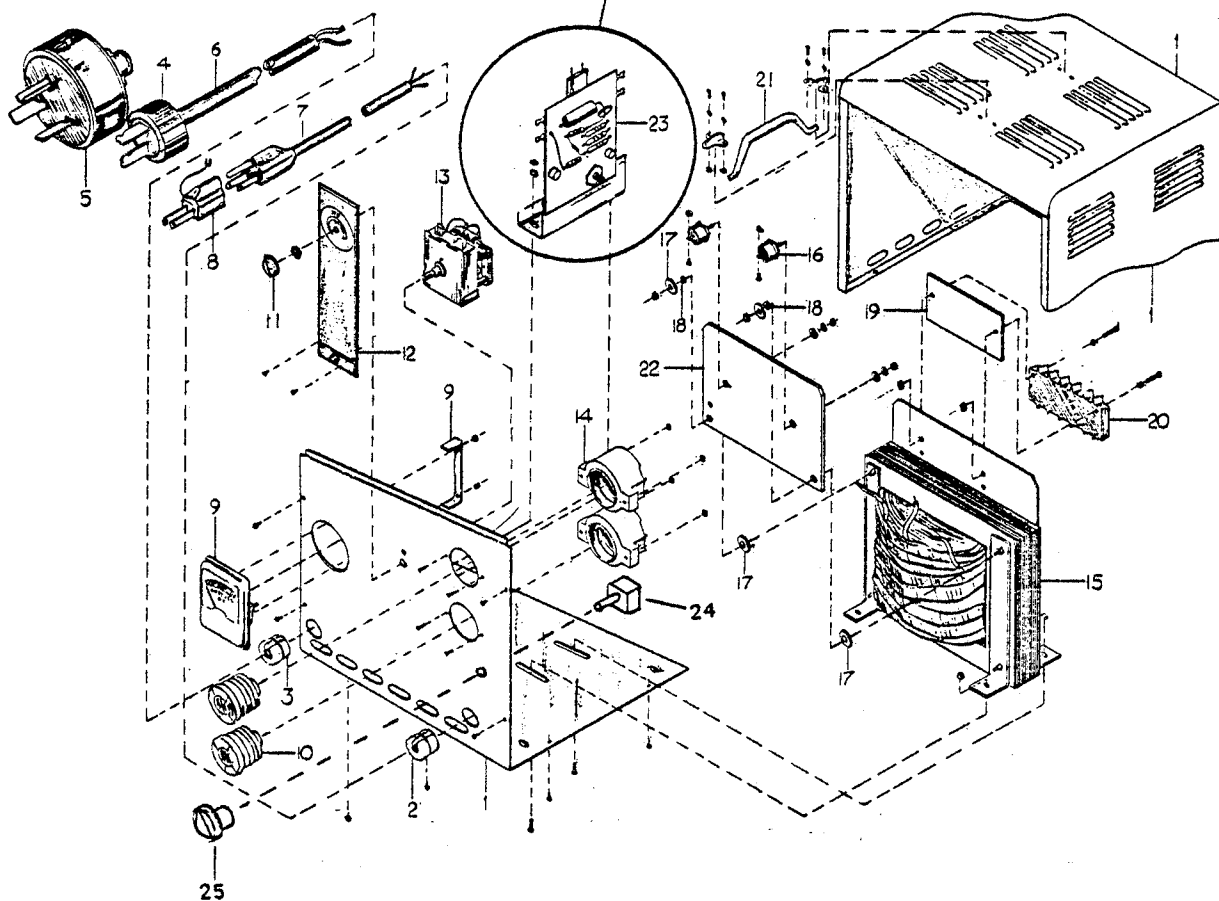

Portable Cabinet Shown.

I.D. Numbers of Internal Components are Identical for Portable and Built In Charger.

PARTS LIST

<u>ITEM</u>	<u>TAYLOR-DUNN PART NO.</u>	<u>ITEM</u>	<u>TAYLOR-DUNN PART NO.</u>
1. Cabinet		15. Transformer, 24V/20A (T Series)	79-630-00
2. Bushing (A-C)	79-530-00	Transformer, 24V/20A (A Series)	79-606-00
3. Bushing (D-C)	79-531-00	Transformer, 24V/30A (T Series)	79-607-00
4. D-C Plug (2 Prongs)	76-001-00	Transformer, 36V/20A (T Series)	79-613-00
5. D-C Plug (3 Prongs)	76-002-00	Transformer, 36V/30A (T Series)	79-614-00
6. Output Cord (no plug) Output Cord w/molded plug	79-560-00	Transformer, 48V/20A (T Series)	79-620-00
7. A-C Cord and Plug (Portable Model)	79-570-00	16. Diode, 24/36V	79-720-00
Molded A-C Assembly (Built-in Model)	79-575-00	17. Washer Assembly, 3/4"	97-170-00
Recessed Male Plug (Built-in Model)	76-251-00	18. Washer Assembly, 3/8"	97-171-00
8. Not Available		19. Mounting Plate	94-325-00
9. Ammeter (0-30 amp)	79-851-00	20. Terminal Board	79-860-00
10. Fuse (30 amp)	79-819-00	21. Handle Assembly	79-509-00
11. Control Knob	79-803-00	22. Not Available	
12. Instruction Plate	94-321-00	23. Voltage Sensing Unit, 24V (T Series)	79-810-00
13. Timer Assembly, 12 Hr. (T Series)	79-800-00	Voltage Sensing Unit, 36V (T Series)	79-811-00
Timer Assembly, 24 Hr. (A Series)	79-801-00	Voltage Sensing Unit,	79-812-00
14. Fuse Holder	79-830-00	24. Tap Switch (Low-Med-High)	79-895-00
		25. Knob, (Low-Med-High)	79-896-00

When ordering parts, please specify both serial number and model of charger.

MODELS 2445 AND 3645
OPERATING AND SERVICING DATA SHEET

INSPECTION AND INSTALLATION

Inspect the exterior of the shipping container for signs of rough handling during shipment.

Remove charger from the shipping container and inspect it for damage (cracked knob, etc.) CLAIMS FOR SHIPPING DAMAGE SHOULD IMMEDIATELY BE FILED WITH THE CARRIER.

The charger may be installed on any suitable working surface (bench or floor). Insure that there is clearance above and around the charger so as to allow free flow of air for cooling.

Remove the panel on back of cabinet to gain access to the terminal panel.

WARNING: Voltages hazardous to life exist at terminal panel when charger is turned on. Turn OFF the charger before making any of the following adjustments.

The adjustment for a charging voltage of 2.50 volts per cell should be made at this time. This is done by monitoring the DC output voltage with a voltmeter (0 to 50 volts) and setting the AC tap lead to the transformer terminal which gives the desired DC output voltage as indicated below. Move the tap connection to the right to increase the DC output voltage. Move the tap connection to the left to decrease the DC output voltage.

<u>DC OUTPUT VOLTAGE SETTING CHART</u>	
<u>MODEL</u>	<u>DC OUTPUT VOLTS</u>
2445	30.0
3645	45.0

If a DC output plug is not furnished with the charger, attach a suitable polarized plug of adequate current capacity to the DC output leads (See NOTE in Step 2 below).

OPERATING INSTRUCTIONS

1. Connect the AC input to the proper power source.
2. Connect the DC output plug to the batteries to be charged.
NOTE: Check the output plug for the correct polarity.
3. Turn on the charger by setting the timer control knob to the desired charging time.
4. Verify that the pilot light illuminates and that the output ammeter indicates a charging current.
5. The timer control will turn off the charger at the completion of the charge cycle
6. Disconnect the charger DC plug from the batteries after the charger is turned off.
7. Using a hydrometer, verify that the batteries are properly charged.

PARTS LIST

79-531-00 Bushing, Ac	94-326-00 Timer Dial	79-714-00 Choke, 36V
79-530-00 Bushing, DC	72-095-00 Pilot Light	79-641-00 Transformer 24V
79-567-00 Cord, DC	79-720-00 Diode	79-642-00 Transformer 36V
79-573-00 Cord, AC	79-852-00 Ammeter	79-862-00 Terminal Panel
79-801-00 Timer	97-170-00 Insulator Washer (3/4")	79-826-00 Fuse (Link)
79-803-00 Control Knob	97-171-00 Insulator Washer (3/8")	71-304-00 Relay, 115V (3645 Only)
	79-713-00 Choke, 24V	

When ordering replacement parts, give model and serial number of charger. Specify wire size number of wires required when ordering cords.

CIRCUIT DIAGRAM
MODELS 2445 & 3645 CHARGERS

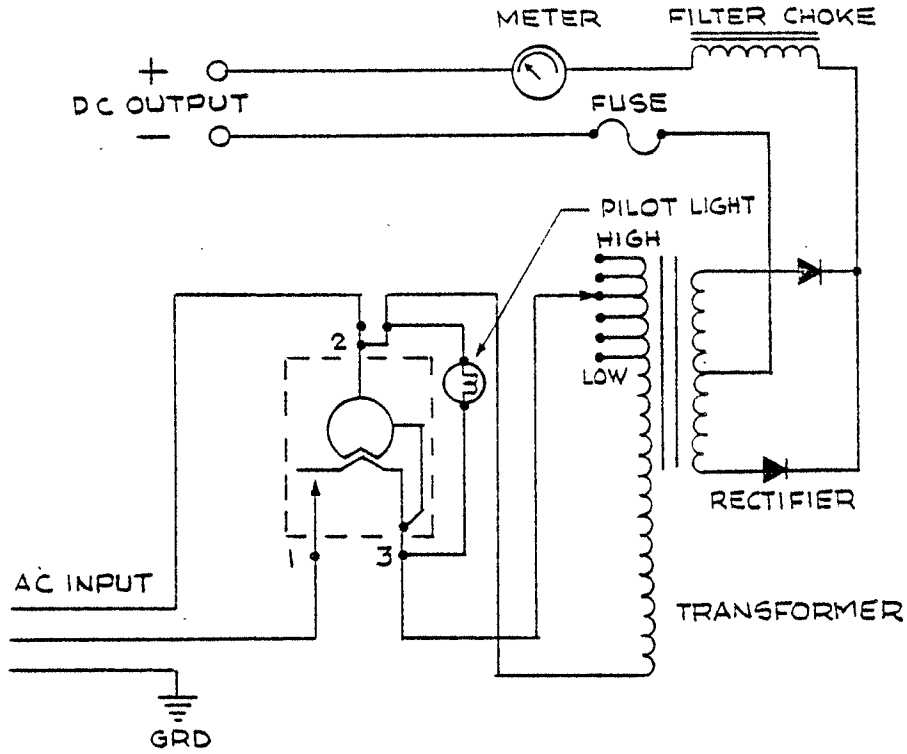

MODEL 2445

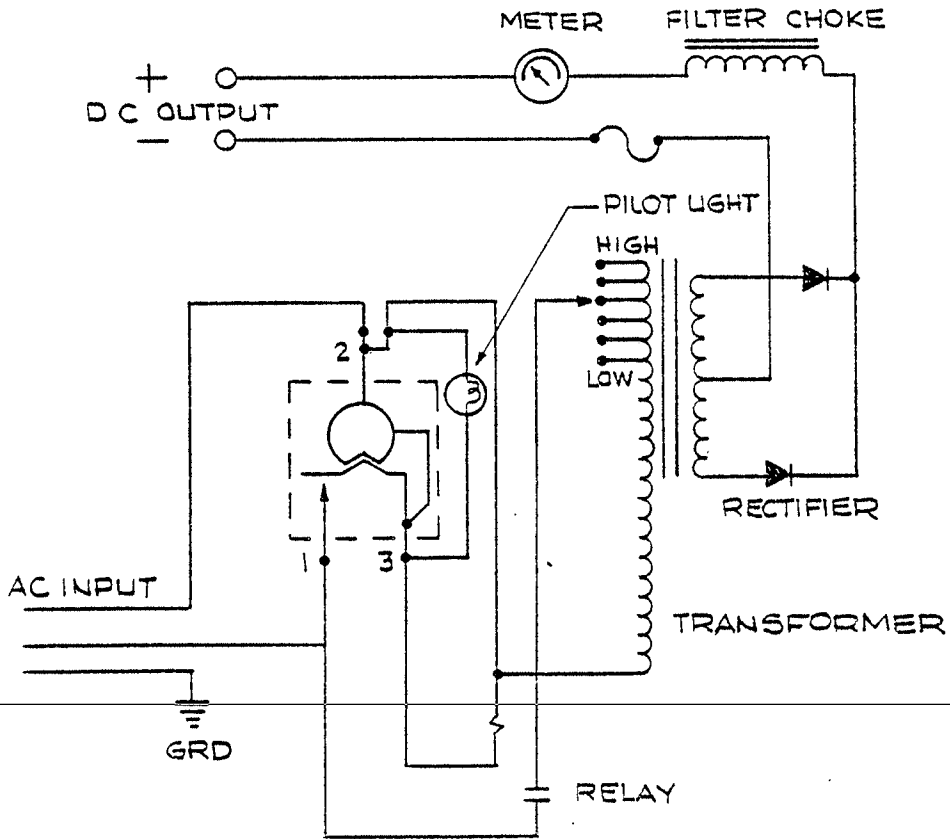

MODEL 3645

MAINTENANCE PROCEDURES
BODY AND TRIM

Your vehicle has been finished with several coats of durable baked on enamel.

It will require the same care as you would give your automobile. The chrome trim is also resistant to corrosion and will require an occasional cleaning.

It is recommended that your vehicle be washed with a mild soap and warm water. For long life a good automotive type of wax will extend the life of the finish and maintain lasting beauty.

T-D PART NO.	DESCRIPTION	QTY. REQ.
50-226-00	1/4" Battery Rod 15½" Plus Bend	3
71-650-00	3" Red Reflector	1 to 4
72-405-00	Guard, Turn Signal Light Fixture (Inside, Front)	1
90-107-00	Seat Back With Arm-Rest Weldment, Model B 3rd Seat	1
90-108-00	Bolt-On Rear Step Weldment, Model B	1
90-114-00	Cover, Right Front Wheel Well Top (Single Seat Model B)	1
90-118-00	Removeable Right Seat Frame Only (Single Seat Model B)	1
90-134-00	Seat Cushion (19" x 39") Model B Foldaway Seat, & Bolt On 3rd Seat, Solid Black	1
90-136-00	Seat Cushion (22½" x 20") Model B Half Cab, Solid Black	1
90-137-00	Seat Backrest (12" x 27-5/8") Model B Half Cab, Solid Black	1
90-140-00	Seat Backrest, Full, Black (or White, 90-140-11)	1
90-142-00	Seat Backrest (12" x 22½") Model B Single Seat (Black)	1
90-143-00	Seat Backrest (12" x 18") Model B removable Right Seat (Black)	1
→ 90-148-00	Seat Cushion (18½" x 20") Model B & M, Solid Black	2
90-149-00	Seat Cushion (20" x 41½") Model M & Model B, Fixed Second Seat, Solid Black	1 or 2
F/R SWITCH IN MID. 90-167-99	Seat Cushion, Model B Deadman Seat w/Electrical Interlock Solid Black	1
90-168-00	Seat Cushion (15½" x 17½") Model B Deadman Seat Without Electrical Interlock, Solid Black	1
90-300-00	Arm Rest (Black) Model B	2
90-444-00	Deck Board, 5/8" Plywood, Black, Hi - Density Cover; 41 x 75½	1
90-539-00	3/4" Round Steel Stake Model B	3
90-540-00	Stake Side, Side Gate Hook	6
90-542-10	Stake Sides and End Assembly (14" High Stakes)	1
90-543-00	1½" x 3/4" Channel Stake 17" Long	6
90-544-00	2" x 1" Stake Pocket, Outer	6
90-544-10	2" X 1" Stake Pocket, Inner	6
90-456-00	1-1/2"X 3/4" Channel Stake 27" Long	6

T-D PART NO.	DESCRIPTION	QTY. REQ.
90-548-00	1-1/2" x 3/4" Channel Stake 39" Long	6
90-800-00	Windshield, Safety Class (19-1/2" x 35-1/2")	1
90-811-00	Windshield & Side Window Safety Class (19-1/2" x 21-1/2") Model B Half Cab	1
90-850-00	Rear Window, Safety Glass (12" x 32")	1
90-851-00	Rear Window, Safety Glass (12" x 18") Model B Half Cab	1
90-908-00	Side Curtains Less Steel Frame for Cab	1 Pair
90-908-98	Side Curtain Less Steel Frame, Left Side (Model B)	1
90-908-99	Side Curtain Less Steel Frame, Right Side (Model B)	1
90-910-00	Metal Enclosure Panel (Less Glass) Model B Half Cab, Right Side Only	1
90-908-62	Kit, Cab Door, Left Side	1
90-908-63	Kit, Cab Door, Right Side	1
90-921-98	Side Curtain Frame, (Less Hinges) Model B Left Side	1
90-921-99	Side Curtain Frame, (Less Hinges) Model B Right Side	1
91-000-00	Fiberglass Cab Without Window Glass (White)	1
91-005-00	Fiberglass Cab Without Window Glass (White) Model B, Half Cab	1
91-006-00	Fiberglass Windshield Only, Frame (White) Model B	1
91-023-98	Support Post for Top Frame, Front Left Side	1
91-023-99	Support Post for Top Frame, Front Right Side	1
91-028-00	Tubular Top Frame (Model B) Less Top Supports	1
91-028-51	Support Post for Top Frame, Rear	2
91-029-00	Windshield Support Bracket with Surrey Top	2
91-101-00	Surrey Top Cover with Fringe	1
91-809-10	Hinge Side Curtain Door Frame Upper	2
91-810-00	Hinge Side Curtain Door Frame Lower	2
92-000-00	Chrome Wheel Cover 8" for 400 x 8 and 500 x 8 Wheel	2 or 4
92-002-00	Chrome Wheel Cover 8" for Split Rim Wheel	2 or 4
92-201-00	4 x 8 Mirror	1
92-202-00	Mirror Bracket	1
94-011-00	Aluminum Trim Drip Rail Formed 56" Long	2
94-034-00	Plastic Trim Strip (Per Foot) for 91-006-00 Windshield Frame	

T-D PART NO.	DESCRIPTION	QTY. REQ.
94-201-00	Taylor-Dunn Emblem	1
94-301-00	Taylor-Dunn Decal	1
94-304-00	Switch Console Name Plate	1
94-305-00	Forward/Reverse Switch Plate	1
95-510-00	Deck Handle	1
95-530-10	Recessed Handle (Model B) Foldaway Seat	1
95-952-00	Paint - 1 Qt. Can (Specify Color)	1
97-315-50	Shaft - 5/16 Square N.C. Thread for Curtain Door Latch	2
97-315-51	Plate - Door Latch (Inner and Outer)	4
97-315-53	Handle - Door Latch (Inner and Outer)	4
97-804-00	Hitch - Pintle (Model B)	1
97-808-00	Hitch - Automatic (Model B)	1
98-200-00	Rubber Brake Pedal Pad	1
98-254-00	Aluminum Accelerator Pedal Pad	1
98-311-00	Window Channel for Front Window (107" Long)	1
98-312-00	Window Channel for Front Window-Half Cab (79" Long)	1
98-313-00	Window Channel for Rear Cab Window (85" Long)	1
98-315-00	Window Channel for Rear Window-Half Cab (57" Long)	1

SERVICE AND ADJUSTMENT
REFER TO FIGURE 4A
STEERING WORM ASSEMBLY

DISASSEMBLE AND REASSEMBLE STEERING WORM

1. Remove 4 bolts from cover and slide steering arm shaft assembly and cover from housing.
2. Mark position of steering column jacket tube clamp for proper reassembly.
3. Loosen steering column jacket tube clamp, and slide jacket tube off of housing and steering column shaft.
4. Remove 4 bolts from housing worm bearing cap and remove steering column worm and shaft assembly.
5. Clean all parts and flush out housing with suitable degreasing solvent. Lightly oil all parts for reassembly.
NOTE: If installing new steering column shaft and worm assembly, worm bearings, or worm bearing cups, it will be necessary to check the worm bearing preload.
6. To check worm bearing preload, install the steering column worm and shaft assembly, bearings, bearing cups, bearing cap and original shims.
7. Tighten 4 bolts to 18-22 ft. lbs. torque.
8. Shaft and worm must not have any bearing looseness or "play" and should not rotate with less than 1-1/4" lbs. torque nor require more than 4-1/2" lbs. of torque.
9. Add or take away shims as needed to produce the desired bearing preload.
10. Inspect steering arm shaft seal and cover gasket. Replace if worn or damaged.
11. Install steering arm shaft and cover assembly. Tighten four cover bolts to 18-22 ft. lbs. torque. NOTE: With steering arm shaft positioned at the center of its travel, there must be no backlash with mating worm and roller. Total preload for assembled unit must be no less than 5-3/4" lbs. torque measured at steering worm shaft not more than 11-1/4" lbs.
12. Adjust total preload to proper limits by loosening locknut on backlash adjusting screw located in cover and turning adjusting screw clockwise to increase preload and counterclockwise to decrease preload. Retighten lock nut securely.
13. Replace steering column jacket tube and clamp in original position.

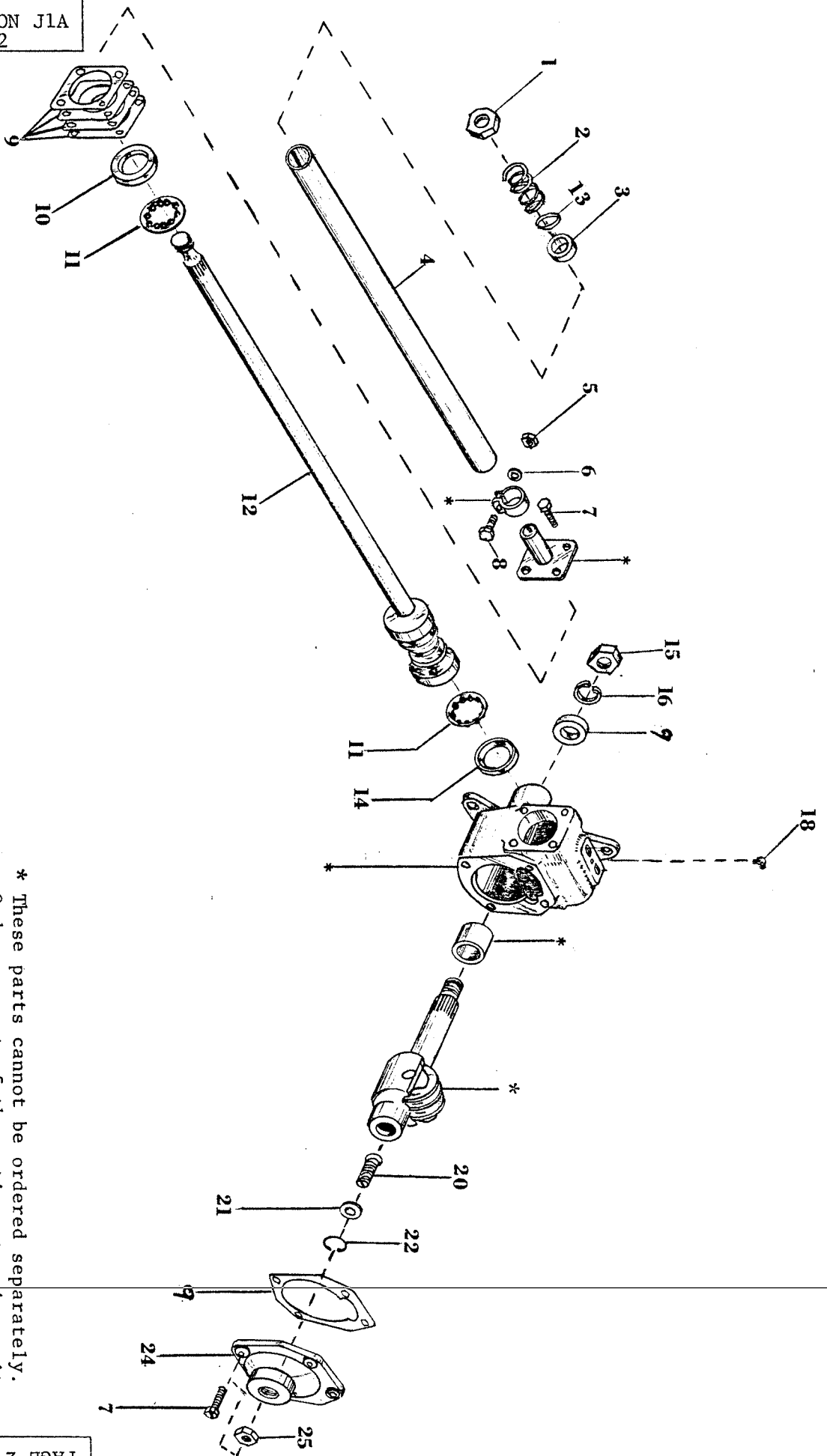

* These parts cannot be ordered separately.
Order as part of the entire steering unit
assembly, part # 18-307-14

NO.	DESCRIPTION	LENGTH	QUAN.	REVISED DATE	REVISION
TOL. FRAC. †	DEC. †				
SCALE	NONE				
DRAWN BY		FIGURE 4A SECTION J1A			
DATE	2-4-77	STEERING WORM ASSEMBLY			
				 TAYLOR DUNN MFG. CO. 2114 West Ball Rd. Anaheim, Calif.	

STEERING WORM ASSEMBLY
REFER TO FIGURE 4A

FIG. I.D. NO.	T-D PART NO.	DESCRIPTION	QTY. REQ.
4A-0	18-307-14	Steering Worm Assembly Complete	1
4A-1	88-259-82	Nut, Jam 13/16 Hex Head, NF	1
4A-2	85-122-00	Spring, Compression 1-1/8 OD x 1	1
4A-3	18-307-54	Spacer, Jacket Bearing	1
4A-4	18-307-52	Jacket, Steering Column	1
4A-5	88-099-80	Nut, 5/16 NF	1
4A-6	88-088-62	Washer, Lock	1
4A-7	88-080-09	5/16 x 3/4 NC Hex Hd Cap Screw	8
4A-8	(Not Available)	5/16 x 2 NF Hex Hd Cap Screw	1
4A-9	18-307-42	Gasket, Seal & Shim Kit for Steering Worm	1
4A-10	18-307-57	Worm Adjustment Bearing Cup, Inner (Requires 18-307-42)	1
4A-11	18-307-53	Worm Bearing Assembly (Requires 18-307-42)	2
4A-12	18-307-51	Steering Column Shaft & Worm Assembly (Requires 18-307-42)	1
4A-13	18-307-55	Spacer, Jacket Bearing	1
4A-14	18-307-56	Worm Bearing Cup, outer (Requires 18-307-42)	1
4A-15	88-279-82	Nut, Jam 7/8 NF Hex	1
4A-16	88-268-62	Lockwasher, 7/8	1
4A-17	18-307-59	Seal, Steering Arm Shaft	1
4A-18	87-073-00	Fitting, Gear 45 degree, 3/16 drive	1
4A-20	18-307-64	Screw, adjusting	1
4A-21	18-307-65	Washer, Thrust	1
4A-22	18-307-66	Snap Ring	1
4A-24	18-307-67	Shaft Cover	1
4A-25	88-159-82	Nut, Jam 1/2" NF	1

N O T I C E O F C H A N G E

WE WANT OUR MANUALS TO BE USEFUL AND CORRECT. IF YOU DISCOVER AN ERROR OR WISH TO SUGGEST CHANGES, PLEASE FILL OUT THIS SHEET AND MAIL IT TO TAYLOR-DUNN.

MANUAL NO. _____ **SERIAL NO.** _____ **DATE:** _____

* AN ERROR(S) EXISTS ON THE FOLLOWING SECTION(S) AND PAGE(S) NO.

SECTION _____ PAGE NO. _____ LINE OR ITEM _____

* **EXAMPLE:** Section 13, Page 5, Item 5.
PART NO. 41-350-55 KIT, CYLINDER REPAIR SHOULD BE PART NO. 41-350-66.

MAIL TO: TAYLOR-DUNN
ATTN: ENGINEERING
2114 W. BALL ROAD
ANAHEIM, CA 92804

=====

N O T I C E O F C H A N G E

WE WANT OUR MANUALS TO BE USEFUL AND CORRECT. IF YOU DISCOVER AN ERROR OR WISH TO SUGGEST CHANGES, PLEASE FILL OUT THIS SHEET AND MAIL IT TO TAYLOR-DUNN.

MANUAL NO. _____ **SERIAL NO.** _____ **DATE:** _____

* AN ERROR(S) EXISTS ON THE FOLLOWING SECTION(S) AND PAGE(S) NO.

SECTION _____ PAGE NO. _____ LINE OR ITEM _____

* **EXAMPLE:** Section 13, Page 5, Item 5.
~~PART NO. 41-350-55 KIT, CYLINDER REPAIR SHOULD BE PART NO. 41-350-66.~~

MAIL TO: TAYLOR-DUNN
ATTN: ENGINEERING
2114 W. BALL ROAD
ANAHEIM, CA 92804

MODEL: B 248, BN

SERIAL NUMBER: 54833 - 74781

YEAR: 1979 - 1983

MANUAL NUMBER: MB-248-00

PRICE: \$25.00

TAYLOR-DUNN LIMITED 90 DAY WARRANTY

TAYLOR-DUNN MANUFACTURING COMPANY (TDMC), warrants each new Taylor-Dunn vehicle for ninety (90) days according to the following terms:

This warranty provides coverage for the original retail purchaser only and becomes effective on the date of the original retail purchase.

Any part of the Taylor-Dunn vehicle manufactured or supplied by TDMC and found in the reasonable judgment of TDMC to be defective in material or workmanship will be repaired and/or replaced at the business location of an authorized Taylor-Dunn distributor only without charge for parts and labor. The Taylor-Dunn vehicle (including any defective part) must be delivered to an authorized Taylor-Dunn distributor within the warranty period.

All costs of a service call regarding warranty-related repairs and/or replacements on the Taylor-Dunn vehicle at the owner's location, the labor performed by the distributor at the owner's location, all costs of delivering the Taylor-Dunn vehicle to the distributor for warranty work and the costs of returning the Taylor-Dunn vehicle back to the owner after repair or replacement will be paid for by the owner. Proof of purchase will be required by the authorized Taylor-Dunn distributor to substantiate any warranty claim. All warranty work must be performed by an authorized Taylor-Dunn distributor.

TDMC does not provide a warranty related to SCR's, tires, batteries, chargers, or other parts not of their manufacture as such parts are usually warranted separately by their respective manufacturers.

This warranty does not include service items subject to normal wear such as brake linings, seals, belts, light bulbs and fuses.

This warranty does not provide coverage for any Taylor-Dunn vehicle that has been subject to misuse, neglect, negligence, accident, or operated in any way contrary to the operating or maintenance instructions as specified in the TDMC operator's manual. The warranty does not apply to any Taylor-Dunn vehicle that has been altered or modified so as to adversely affect the vehicle's operation, performance or durability or that has been altered or modified so as to change its intended use. In addition, the warranty does not extend to repairs made necessary by normal wear, or by the use of parts or accessories which in the reasonable judgment of TDMC are either incompatible with the Taylor-Dunn vehicle or adversely affect its operation, performance or durability.

Repairs or replacements qualifying under this warranty will be performed by an authorized Taylor-Dunn distributor following delivery of the vehicle to the distributor's place of business. TDMC's responsibility in respect to claims is limited to making the required repairs or replacements. No claim of breach of warranty shall be cause for cancellation of the contract of sale of any Taylor-Dunn vehicle.

TDMC assumes no liability or responsibility for loss of use of the Taylor-Dunn vehicle, loss of time, inconvenience, or other damage, consequential or otherwise, including, but not limited to, all costs for delivering the Taylor-Dunn vehicle to the distributor and all costs of returning the vehicle back to the owner, mechanic's travel time, telephone or telegram charges, trailering or towing charges, rental of a like vehicle during the time warranty repairs are being performed, travel, lodging, loss or damage to personal property, or loss of revenue.

TDMC reserves the right to change or improve the design of any vehicle without assuming any obligation to modify any TDMC vehicle previously manufactured.

All implied warranties are limited in duration to the ninety (90) day warranty period. Accordingly, any such implied warranties

including merchantability, fitness for a particular purpose, or otherwise, are disclaimed in their entirety after the expiration of the ninety (90) day warranty period. TDMC's obligation under this warranty is absolutely and exclusively limited to the repair or replacement of defective parts, and TDMC does not assume, or does not authorize anyone to assume for them, any other obligation.

This warranty applies to all TDMC vehicles sold in the United States.

WARRANTY SERVICE

To make a claim under warranty, contact an authorized Taylor-Dunn distributor immediately upon realizing a problem exists. We recommend having the warranty work performed by the distributor who originally sold you the vehicle; however, warranty work can be obtained from any authorized Taylor-Dunn distributor. Remember, your Taylor-Dunn vehicle must be delivered to an authorized distributor within the warranty period, and all warranty work must be performed only by an authorized Taylor-Dunn distributor. Your proof of purchase will be required by the dealer to verify any warranty claim.

Examples of Items Not Covered by Warranty

Provisions of the warranty will not apply to:

Normal service requirements occurring during the warranty period, such as adjustment and cleaning or wear of a drive belt, drive chain, brake or rheostat.

Normal service work over and above the repair and replacement of defective parts. Vehicles subject to misuse, neglect, negligence, or accident.

Vehicles that have been altered or modified so as to adversely affect their operation, performance or durability or to change their intended use.

Repairs made necessary by the use of parts or accessories which are either incompatible with the vehicle or adversely affect its operation, performance or durability.

Vehicles not operated or maintained in accordance with the instructions in the Taylor-Dunn Operator's Manual.

Periodic checking, lubricating the vehicle or service check-up.

All costs of delivering the vehicle to the distributor and all costs of returning the vehicle back to the owner, mechanic's travel time, trailering or towing charges, or rental of a like vehicle during the time warranty repairs are being performed.

This warranty applies only to the original retail purchaser. Second-owner or subsequently owned vehicles are not covered under the warranty.

Owner's Obligation and Responsibility

Normal maintenance service and replacement of service items are the responsibility of the owner and as such are not considered defects in material or workmanship with the terms of this warranty. Individual operating habits and usage may contribute extensively to the need for maintenance service.

Consult with your authorized Taylor-Dunn distributor for advice on proper maintenance and care of your vehicle. Proper maintenance and care will be very helpful in keeping your overall operating costs at a minimum.

To assure warranty coverage, it is the owner's responsibility to maintain all components in proper adjustment and to service the vehicle as specified in the Taylor-Dunn Vehicle Operator's Manual. It is the owner's responsibility to provide proper lubrication for all components and provide correct recommended battery maintenance, to maintain the battery liquid level and charge as specified, as well as maintain the correct pressure in the tires of the vehicle.