

**OPERATION**  
AND  
**MAINTENANCE**  
**MANUAL**  
WITH  
**PARTS LIST**

MODEL: G 1-50  
SERIAL #: Starting at 127633  
MANUAL # MG-150-01

**\*\*IMPORTANT\*\***

READ AND FOLLOW INSTRUCTIONS GIVEN IN  
SAFETY AND OPERATIONS SECTIONS, AND  
THOSE SECTIONS RELATED TO YOUR  
SERVICE AND REPAIR RESPONSIBILITIES.



**TAYLOR-DUNN**<sup>®</sup>  
*Commercial and Industrial Vehicles Since 1949*

2114 W. Ball Rd., Anaheim, CA 92804 (714) 956-4040 (FAX) (714) 956-5063

Mailing address: P.O. Box 4240, Anaheim, CA 92803

Visit our Website @ [www.taylor-dunn.com](http://www.taylor-dunn.com)

# TABLE OF CONTENTS

## SECTION 1: INTRODUCTION

About this manual	1-2
Notational conventions	1-3
Vehicle description	1-4
Frame specifications	1-6
Engine specifications	1-7
Taking delivery of your vehicle	1-8

## SECTION 2: OPERATING GUIDELINES

Safety rules and guidelines	2-2
Driver training	2-3
Vehicle controls	2-4
Starting	2-7
Driving	2-9
Loading and Unloading	2-9
Parking	2-10
Towing	2-10

## SECTION 3: SCHEDULED MAINTENANCE AND SERVICE PROCEDURES

Maintenance Guidelines	3-3
Maintenance Checklist	3-4
Lubrication Chart	3-6
Troubleshooting Guide	3-7
Maintenance Procedures	3-9
Fuel Recommendations	3-9
Fuel Filter	3-9
Oil Recommendations	3-10
Checking and Changing Oil	3-11
Air Cleaner	3-12
Ignition	3-13
Shifter Cable	3-14
Battery	3-14
Tires	3-18
Brake System	3-19
Front Axle and Steering	3-25
Drive Assembly	3-31
Throttle Cable	3-34
Removing Transmission	3-35
Removing Engine	3-36
Storing and Returning Cars to Service	3-37

# TABLE OF CONTENTS

## ILLUSTRATED PARTS LIST

Front Axle/Front Brakes	2
Front Suspension	4
Steering Gear/Drag Link	6
Parking Brake	8
Foot Brake	10
Rear Brakes	12
Hydraulic Brake Lines	14
Accelerator Pedal Linkage	16
Shifting Linkage Prior to S/N 127633	18
Engine Mount Prior to S/N 127633	20
CVT Drive (Belt)	22
Rear Suspension	24
Fuel Tank	26
Instrument Panel	28
Wire Diagram	30
Electrical System	31
Frame Components	32
Decals/Warning Labels	34
Engine Mount After S/N 127633	38
Shifting Linkage After S/N 127633	40

# INTRODUCTION

G1-50



## **ABOUT THIS MANUAL**

This manual provides you with information you need to safely operate and maintain this vehicle.

We assume that those who will perform maintenance operations are trained vehicle service technicians capable of performing routine maintenance procedures such as changing a tire using a voltmeter and so forth.

We also assume that they have or will attend a training program designed to familiarize them with the safe operation and use of this particular vehicle.

This manual contains the following major sections:

### **SECTION 1: INTRODUCTION**

Contains information about how to use this manual, a description of the G 1-50, and how to do a incoming vehicle inspection. In addition, to the general specifications of the vehicle.

### **SECTION 2: VEHICLE OPERATION**

Provides safety rules and guidelines describes the driver training program and explains the operation of each control on the G 1-50.

### **SECTION 3: MAINTENANCE PROCEDURES**

Contains a scheduled maintenance checklist, lubrication diagram, troubleshooting guide, recommended spare parts list, and detailed maintenance procedures.

### **SECTION 4: SERVICE PROCEDURES**

Contains service procedures in alphabetical order for each assembly found in the G 1-50. Each major heading contains procedures organized in logical order.

### **SECTION 5: ILLUSTRATED PARTS**

Includes an illustration and parts list for each assembly that has replaceable parts for the G 1-50.

## NOTATIONAL CONVENTIONS

The following types of notations are used throughout this manual:

### **▲WARNING**

*A warning alerts you of something that may cause injury to yourself or others. Be sure you exercise special care and follow any instructions provided in a warning message.*

### **▲CAUTION**

*A caution informs you of something that may cause damage to the vehicle. Be sure you exercise special care and follow any instructions provided in a caution message.*



A NOTE PROVIDES ADDITIONAL INFORMATION ABOUT A SUBJECT.

## VEHICLE DESCRIPTION

This manual applies to vehicles with serial numbers starting at 127633 with the Onan engine.

The G1-50 is designed to be driven on smooth surfaces in and around industrial plants, nurseries, institutions, motels, mobile home parks, and resorts.

This vehicle is not designed to be driven on public highways. It is not designed to go more than 18 mph whether on a level or on a downhill surface. Driving at a speed higher than 18 mph may result in steering difficulty, engine damage, and/or loss of control. It is not designed to be towed more than 5 mph.

The vehicle can handle a total payload (incl. cargo, optional equipment, passengers and driver) of up to 1500 lbs.

Various options are available to enable you to customize the vehicle to suit your particular needs (consult your Taylor-Dunn salesperson or representative for current options).

This vehicle conforms to requirements for Type G vehicles as described in O.S.H.A. Standard Section 1910.178 (Powered Industrial Trucks) and with all applicable portions of the American National Standard for Personnel and Burden Carriers (ANSI B56.8-1988).

The model and serial number for this vehicle are imprinted on a decal located under the driver's seat and stamped in a main frame rail directly below the passenger seat.

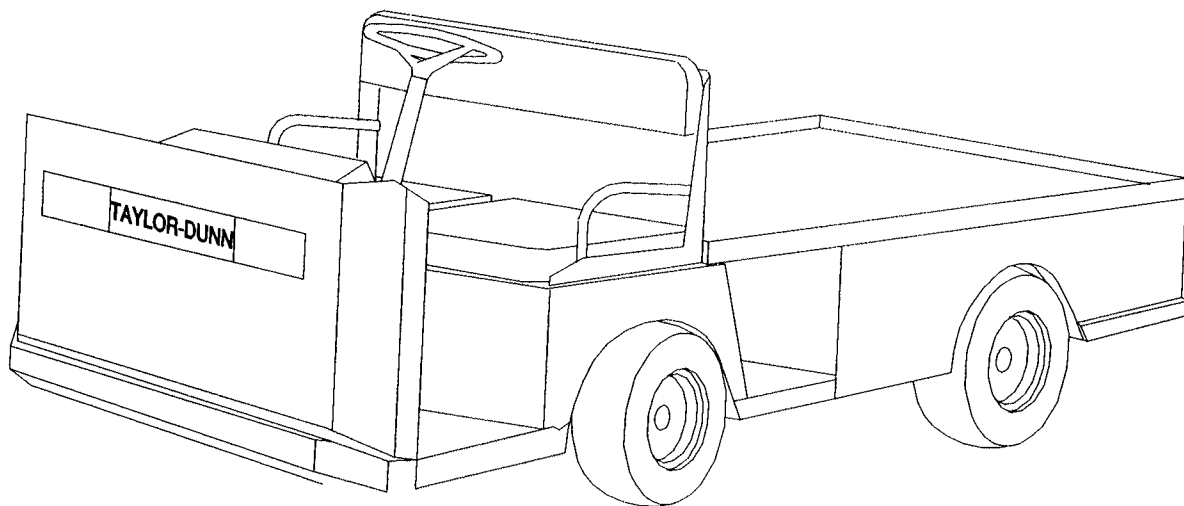

## **Vehicles with Serial Numbers Greater Than 127633**

When you do your inspection of the vehicle as described on page 1-6. Make a note of your serial number. If it is greater than the number above then you vehicle is equipped with a different drive or transmission than what is described in this manual. The servicing, repair, and removal procedures of the new drive are the same as the old drive. Thus, the instructions have not been modified. You will find a drawing and parts list for the new drive on pages 4-38 and 4-40.



## STANDARD SPECIFICATIONS G1-50

ITEM	SPECIFICATION
Standard dimensions	304.8L x 112.4W x 122H Centimeters
	120 x 44 1/4 x 48H Inches
	Bed size 76 1/4 x 36 Inches
Dry weight	517 kg
	1,140 lbs.
Turning radius	312 centimeters
	125 Inches
Transmission/Drive	Automatic variable pitch V-belt transmission.
	Double reduction helical gear, 13.87:1
Brakes	Hydraulic disc on front
	Hydraulic drum on rear
Engine	See table "ENGINE SPECIFICATIONS"
Tires	5.70 x 8 Load range B, pneumatic
Tire pressure	50 psi max.
Maximum load	1500 lbs. (681kg) including driver, passengers and optional equipment
Battery	Group 24, 12 volt

Introduction Table 1

## ENGINE SPECIFICATIONS G1-50

SPECIFICATION	
ITEM	UNITS
Power rating @3600rpm	14 hp
	10.40 kW
Displacement	23.70 Cu. In.
	389 cc
Bore	3.31 in
	84.20 mm
Stroke	2.76 in
	70 mm
Compression ratio	8.5:1
Weight	81.60 lbs.
	37.00 kg
Oil capacity	1 US qt.
	0.90 L
Oil type	SAE 30 Type SF or SG motor oil
Lubrication system	Pressurized with a replaceable filter
Spark plug	Champion RL-95YC
Spark plug gap	0.04 in
	0.89 mm
Spark plug torque	20.00 ft-lbs.
	26.00 Nm

Introduction Table 2

## TAKING DELIVERY OF YOUR VEHICLE

THIS VEHICLE SHOULD BE INSPECTED IMMEDIATELY AFTER DELIVERY. Use the following guidelines to make sure there are no obvious problems.

### Inspecting the Vehicle

Examine the contents of all packages and accessories that may have come in separate packages with this vehicle. Make sure everything listed on the packing slip is there. Nothing should look broken or damaged.

Examine any visible wiring for obvious signs of damage. Check that all connections are secure.

Check that battery connections are tight and all cells are filled.

Inspect the tires for obvious wear or damage. Check the tire pressure. Make sure that all wheel lugs are secure.

Check the body seats windshield (optional) trim and other external parts for obvious damage.

### ***Checking the Controls***

Operate each of the following controls before turning on the key-switch:

- ◆ Accelerator pedal
- ◆ Brake pedal
- ◆ Forward - reverse selector lever
- ◆ Parking brake
- ◆ Steering wheel
- ◆ Horn
- ◆ Lights

Each control should operate smoothly and easily without sticking or requiring undue effort.

***What To Do If You Find A Problem***

If you find a problem with this vehicle, you must immediately file a claim with the carrier. The claim must be filed within 48 hours of receiving this vehicle. Forward a copy of the damage claim to your Taylor-Dunn dealer.

Do not repair modify or adjust any part of this vehicle unless you are authorized to do so. Incorrect repairs may result in injury to yourself and others and cause the invalidation of your warranty.

 **IF YOUR VEHICLE HAS, A SERIAL NUMBER GREATER THAN 127175, REFER TO PAGE 4-36 AND 4-37 FOR PART LOCATIONS ON THE NEW DANA DRIVE.**

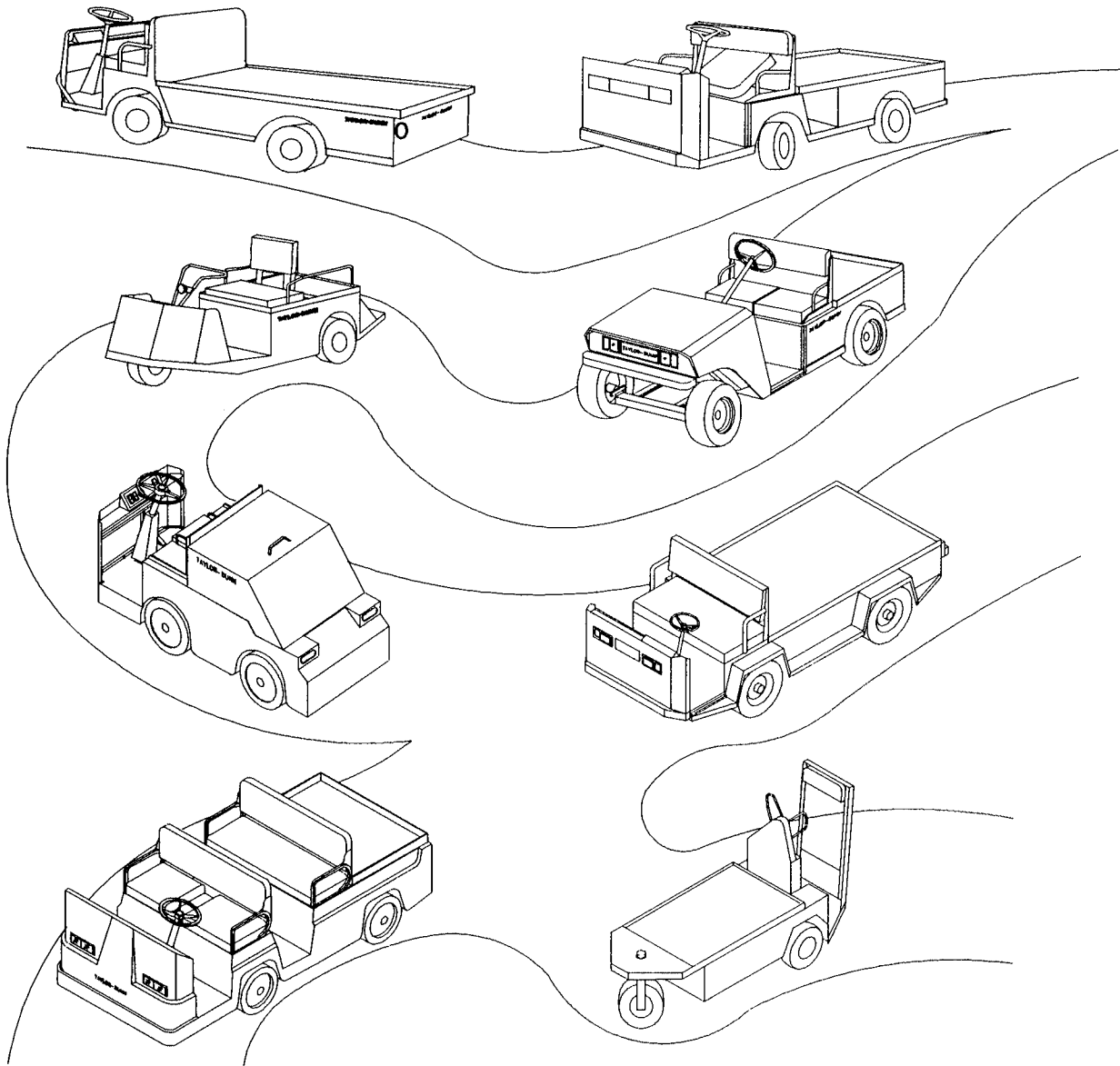

***You're in great company with  
Taylor-Dunn<sup>®</sup>***

# OPERATING GUIDELINES

## G1-50



## SAFETY RULES AND GUIDELINES

It is the responsibility of the owner of this vehicle, to insure that the operator understands, the various controls, and operating characteristics of this vehicle, and obeys the following safety rules, and guidelines. (Extracted from the American National Standards Institute Personnel and Burden Carriers ANSI B56.8)

This vehicle is designed to be driven over smooth surfaces in and around places such as warehouses, nurseries, motels, parks, and resorts. Before you drive this vehicle, please observe the following safety rules and guidelines:

### **⚠ WARNING**

***Do not drive this vehicle on public roads and highways. Do not exceed 18 MPH at any time. Speeds over 18 MPH may cause steering difficulty and loss of control and engine damage.***

Do not drive this vehicle unless you are a qualified and trained operator.

Keep all body parts (head, arms, and legs) inside this vehicle while it is moving. Drive slowly when making a turn especially if the ground is wet slippery or when driving on an incline.

- ◆ This vehicle may overturn easily if turned sharply when driving at high speeds, especially when on an incline.
- ◆ Drive only on level surfaces or on surfaces having an incline of no more than 10% (6° degrees.).
- ◆ Do not drive over loose objects, holes, or bumps.
- ◆ Observe all traffic regulations and speed limits (18-mph max.).
- ◆ Keep to the right under normal conditions.
- ◆ Maintain a safe distance from all objects.
- ◆ Keep the vehicle under control at all times.
- ◆ Yield right of way to pedestrians, ambulances, fire trucks, or other vehicles in emergencies.
- ◆ Do not overtake another vehicle at intersections, blind spots, or other dangerous locations.
- ◆ Keep a clear view ahead at all times.

## **DRIVER TRAINING PROGRAM**

The owner of this vehicle shall conduct an Operator Training program for all those who will be operating this vehicle. The training program shall not be condensed for those claiming to have previous vehicle operation experience. Successful completion of the "Operator Training Program" shall be required for all personnel who operate this vehicle.

The Operator Training program shall include the following:

- ◆ Operation of this vehicle under circumstances normally associated with your particular environment.
- ◆ Emphasis on the safety of cargo and personnel.
- ◆ All safety rules contained within this manual.
- ◆ Proper operation of all the vehicles controls.
- ◆ A vehicle operation and driving test.

## **Driver Qualifications**

Only those who have successfully completed the "Operator Training Program" are authorized to drive this vehicle. Operators must possess the visual auditory physical and mental ability to safely operate this vehicle as specified in the American National Standards Institute Controlled Personnel and Burden Carriers ANSI B56.8.

The following are minimum requirements necessary to qualify as an operator of this vehicle:

- ◆ Demonstrate a working knowledge of each control.
- ◆ Understand all safety rules and guidelines as presented in this manual.
- ◆ Know how to properly load and unload cargo.
- ◆ Know how to properly park this vehicle.
- ◆ Recognize an improperly maintained vehicle.
- ◆ Demonstrate ability to handle this vehicle in all conditions.



## VEHICLE CONTROLS

The following describes the use of each control on this vehicle.

Some controls are optional equipment and may not be installed on this vehicle.

### Key-Switch /Starter

A key-switch located on the right side of the instrument panel starts the vehicle. Rotate the key clockwise to turn the vehicle on counterclockwise to turn the vehicle off. Rotate the key-switch all the way clockwise to start the vehicle just like most cars.

The vehicle will NOT START unless the forward-reverse shift lever is in the neutral (center) position and driver is seated.

This switch is also designed to secure and disable the vehicle. You can remove the key ONLY when the key-switch is in the OFF position.

### Deadman Switch

A switch located under the driver's seat disables the vehicle when the driver leaves the seat. The driver must be seated for the engine to run.

This is an added safety feature and should never be bypassed.

### Choke Knob

The choke knob is located between the front seats behind the forward-reverse shift lever. When starting a cold engine pull out the choke knob until the engine responds properly, as the engine warms up push the knob in.

## Forward-Reverse Shift Lever

The forward-reverse shift lever located between the driver and front passenger seats determines the direction of travel (forward or reverse,) of the vehicle. Push knob down and then forward of the neutral (center) position to make the vehicle travel forward. Push knob down and then pull it back past the neutral position to go in reverse.

### **⚠ CAUTION**

*DO NOT SHIFT from forward to reverse or vice-versa while the vehicle is in motion. Make sure the vehicle is completely stopped before shifting. Shift only when the engine is at idle speed. Damage to the transmission may result.*

The shift lever has a detent in the forward, reverse and neutral positions. The shift lever should be in the neutral position with the park brake set whenever the operator leaves the driver's seat.

## Accelerator Pedal

The accelerator pedal located to the right of the brake pedal, and it controls the speed of the vehicle, it is designed for right foot operation. It operates the same way as the accelerator pedal in an automobile and controls the vehicle's SPEED while the forward/reverse shift lever controls the DIRECTION of motion.

Depress the pedal to speed the vehicle up. Release the pedal to slow down.

The foot brake pedal will need to be used to slow this vehicle on a downgrade.

## Steering

The steering wheel and steering system is an automotive type. To turn right, turn the steering wheel to the right (clockwise). To turn left, turn the steering wheel to the left (counter clockwise).

## Foot Brake Pedal

The foot brake pedal located to the right of the steering column is for operation with the right foot only. It works the same as the brake in an automobile. Applying pressure to the brake pedal slows the vehicle according to the amount of pressure you apply. Removing your foot from the pedal releases the braking action.

## **Park Brake Lever**

The park brake is actuated with a hand lever located on the kick panel between the front seats. To set the park brake push down on the lever. To release the park brake, pull up on the lever.

**Tip:** For easier application of the park brake step on the foot brake pedal while applying the park brake.

## **Horn Button**

The horn button is located on the floorboard to the left of the steering column. The horn buttons is to be operated by the left foot. Depress the button to sound the horn and release the button to stop the horn from sounding.

## **Instrument Panel**

The headlight switch is located on the left side of the instrument panel. An accessory switch, if any, is adjacent and to the right of it.

## **Hour Meter**

The hour meter is located to the right of the fuel gauge. This tracks the number of hours the engine has been in operation.

## **Fuel Gauge**

The fuel gauge is located to the right of the accessory switch. The gas filler cap is located on the right panel towards the rear of the truck.

## STARTING AND DRIVING THE VEHICLE

### Before Starting

Pre-start checklist:

- ◆ Check oil level. Add oil if low.
- ◆ Check fuel level. Add fuel if low.
- ◆ Make sure cooling air intake areas and external surfaces of the engine are clean and unobstructed.
- ◆ Check that all air cleaner components and all shrouds equipment covers and guards are in place and securely fastened.
- ◆ Check that the transmission is in the center (neutral) position.

### **▲WARNING**

*Never run the engine in a closed building or confined area and avoid inhaling engine fumes. The exhaust gases contain poisonous carbon monoxide.*

### Starting

1. If the engine is cold, place the choke control in the "ON" position. If the engine is warm (in normal operating temperature) place the choke control in the "OFF" position.
2. Depress the accelerator pedal halfway to the floor.
3. Rotate the key-switch clockwise all the way to engage the starter just as you would start your own cars. Release the key-switch as soon as the engine starts.

### **▲CAUTION**

*Do not crank the engine continuously for more than 10 seconds at a time. If the engine does not start, wait 60 seconds before attempting to start again. Failure to follow these guidelines can burn out the starter motor.*

### **▲CAUTION**

If the engine starts but does not keep running (a false start), wait for the engine to stop completely before restarting. Starting the engine while the flywheel is still rotating can damage the starter.

**⚠ CAUTION**

*If the starter does not turn the engine over, release the key switch immediately. Do not try to start the engine again until the problem is corrected. Do not jump start using another battery as this may burn out the starter motor.*

4. On a cold engine gradually return the choke control to the "OFF" position as the engine warms up.

## Driving

- ◆ Slow down, and sound the horn when approaching a corner or other blind intersection.
- ◆ No horseplay or dangerous driving.
- ◆ Do not drive this vehicle in hazardous areas unless this vehicle is approved and labeled for such operation.
- ◆ Immediately report any accident or vehicle problem to your supervisor.

## Loading and Unloading

- ◆ Do not load cargo that can easily fall off this vehicle.
- ◆ Do not exceed the cargo load capacity of this vehicle.
- ◆ Do not carry more than the maximum number of passengers allowed for this vehicle.
- ◆ Do not handle cargo that is longer, wider, or higher than this vehicle.

## Parking

- ◆ Set the parking brake and place shift lever in neutral before leaving the vehicle.
- ◆ If you will be away from this vehicle turn off the key-switch, and take, it with you.
- ◆ If you park this vehicle on an incline block the wheels.
- ◆ Do not block fire aisles, fire equipment, or stairways.

## Towing

- ◆ To tow these vehicles attach a tow strap to the front bumper-tow bar and place the forward/reverse shift lever in the neutral position.
- ◆ Use another driver to steer this vehicle while it is being towed; be sure the driver uses the brakes when you slow or stop the towing vehicle.

### **⚠ WARNING**

***Do not exceed 5 MPH or carry any passengers while towing this vehicle.***

## NOTES



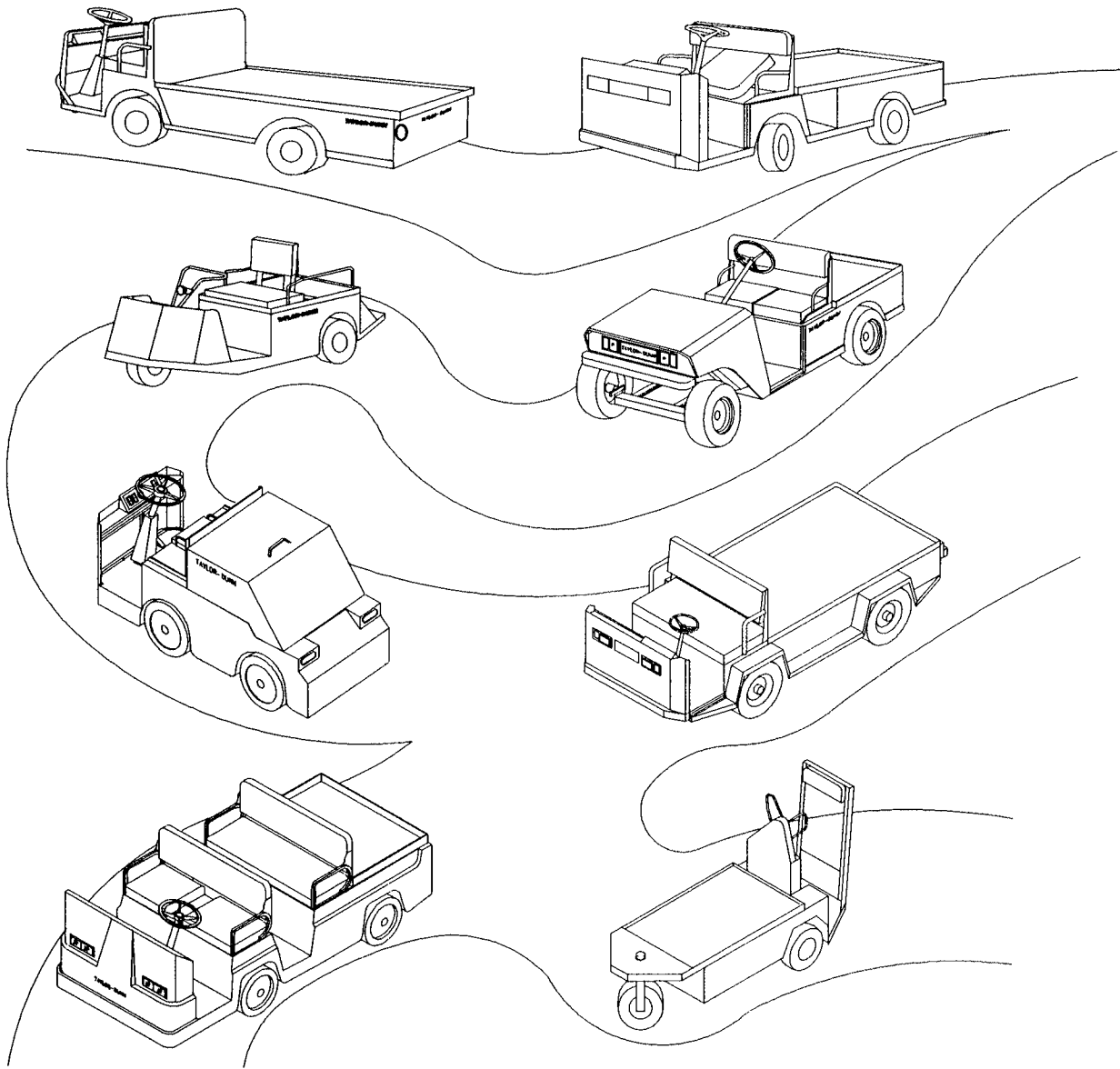

***You're in great company with  
Taylor-Dunn®***

**SCHEDULED MAINTENANCE**  
**AND**  
**SERVICE PROCEDURES**  
**G1-50**



*This section explains how to perform the scheduled maintenance procedures. Use the Maintenance Checklist to determine how often you should perform each procedure. Vehicle maintenance or repairs should only be performed by a qualified mechanic.*

This section contains the following:

- ◆ Maintenance guidelines.
- ◆ Maintenance checklist.
- ◆ Lubrication chart.
- ◆ Troubleshooting guide.
- ◆ Recommended spare parts list.
- ◆ Detailed maintenance procedures.

## Maintenance Guidelines

- Allow only qualified and authorized personnel to maintain repair adjust and inspect the vehicle.
- Before starting any repairs or maintenance immobilize the vehicle by turning the ignition off, setting the key switch to the "OFF" position, removing the key and setting the park brake.
- Disconnect the battery leads before working on or disconnecting any electrical component or wire.
- Block the chassis with jack stands before working under a raised vehicle.
- Conduct vehicle performance checks in an authorized area where safe clearance exists.

Before starting the vehicle, follow the recommended safety procedures in Section 2, "Vehicle Operation."

- Avoid fire hazards and have fire protection equipment present in the work area. Do not use an open flame to check level or leakage of fuel, battery electrolyte, or coolant. Do not use open pans of fuel or flammable fluids for cleaning parts.
- Ventilate the work area properly.
- Regularly inspect and maintain in a safe working condition, brakes, steering mechanisms, speed and directional control mechanisms, warning devices, lights, governors, guards and safety devices.
- Check the fuel system for leaks and condition of parts. If a leak is found take action to prevent the use of the vehicle until the leak has been eliminated.
- Inspect and maintain battery limit switches, protective devices, electrical conductors and connections in conformance with Taylor-Dunn's<sup>®</sup> recommended procedures.

Keep the vehicle in clean condition to minimize fire hazards and facilitate detection of loose or defective parts.

SECTION 3  
MAINTENANCE



PERIODIC MAINTENANCE CHECKLIST					
Maintenance Item	Weekly (20 hrs)	Monthly (80 hrs)	Quarterly (250 hrs)	Semi-yearly (500 hrs)	Yearly (1000 hrs)
Check tire pressure (50 psi)	X				
Check and fill battery (use distilled water only)	X				
Check foot brake system. Adjust if necessary		X			
Check belts and mounts.		X			
Check steering for play. Adjust as necessary		X			
Check control cables		X			
Check steering spline coupling setscrew.		X			
Lubricate all Zerk fittings			X		
Lubricate all moving parts without Zerk fittings (use all-purpose oil)			X		
Clean and tighten all wire connections			X		
Wash battery with water (use soda if necessary)			X		
Check brake lining for wear. Adjust as necessary				X	
Check and adjust front wheel bearings				X	
Check rear axle oil				X	
Change rear axle oil (Only on old style drives.)					X
Replace air filter element					X
Check nuts and bolts, particularly engine and drive train					X
Clean and re-pack front-wheel-bearings (use wheel-bearing grease).					X
<b>NOTE:</b> For Engine Maintenance, see next table, "Engine Maintenance".					

## ENGINE MAINTENANCE

REQUIRED MAINTENANCE	
Maintenance item	Frequency*
Clean air intake screen	Daily
Check oil level	Daily
Change oil	100 Hours
Fill fuel tank	As required
Replace fuel filter	400 Hours
Service foam air filter	50 Hours
Clean cooling fins and external surfaces	50 Hours
Check paper air filter	200 Hours
Check spark plug	200 Hours
Replace spark plug	400 Hours
Check valve-tappet clearance	200 Hours
*More frequently when the engine is operated under extremely dusty or dirty conditions.	

## LUBRICATION CHART

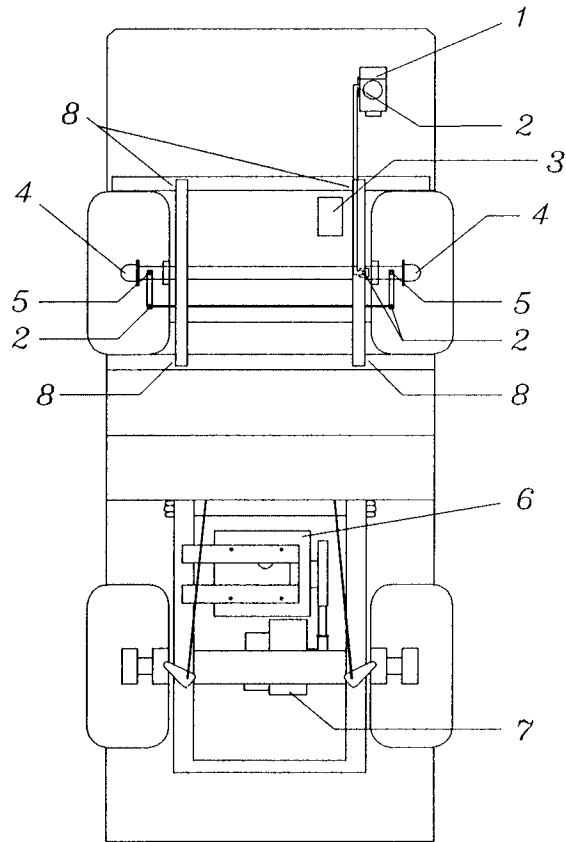

#	Description	Location	Lubricant type
1	Steering gear box	1	General purpose grease
2	Steering ball joints	4	General purpose grease
3	Master cylinder	1	DOT 5 Brake fluid
4	Front wheel bearings	2	General purpose grease
5	King pin	2	General purpose grease
6	Engine oil	1	SAE 30 Detergent motor oil
7	Transmission	1	SAE 30 Non-detergent motor oil
8	Front Leaf Spring hangers	4	General purpose grease

## TRUBLESHOOTING GUIDE

SYMPTOM	PROBABLE CAUSE*
Steering pulls in one direction	Unbalance tire pressure
	Front end out of alignment
Hard steering	Low tire pressure
	Dry lube points in steer linkage
	Damaged king pin/Ball joint
Excessive steering play	Worn ball joints
	Mis-adjusted or worn steer gear
	Loose steering linkage
Lack of power or slow operation	Brake dragging
	Parking brake dragging
	Worn transmission gears
	Front end out of alignment
	Mis-adjusted throttle cable
Abnormal noise	Worn transmission gears or bearings
	Worn axle bearing (front or rear)
	Loose wheel lug nuts
	Engine bearings worn
Oil leak in rear wheel bearing area	Wheel bearing and/or gasket failed
	Transmission overfilled
Brake pedal soft or spongy	Air in brake lines
Brake pedal low	Brake worn (1/16" wear limit)
	Brake fluid low
	Brakes out of adjustment
Braking power low	Brakes worn (1/16" wear limit)
	Brake shoes/pads contaminated with fluid
	Brake pedal linkage binding
	Brakes out of adjustment
	Air in brake lines



## TROUBLESHOOTING GUIDE (CONT.)

SYMPTOM	PROBABLE CAUSE*
Poor idle or low speed performance	Spark plug fouled
	Choke on
	Carburetor out of adjustment
	Weak spark
	Fuel pump failed
	Air leak in intake manifold
	Plugged fuel tank vent
* Probable causes are to be used as a guide only. They are not all inclusive of the problems that can result with the symptom indicated	

## MAINTENANCE PROCEDURES

### Fuel

Use only clean fresh unleaded gasoline with a pump sticker-octane-rating of 87 or higher (for countries using the Research method octane rating should be 90 or higher).

During some times, of the year only mandated "oxygenated" gasoline's may be available. These are acceptable for use but not preferable. Leaded gasoline may be used in this vehicle. However, the use of leaded fuel will result in extra maintenance, to remove combustion chamber, and spark plug deposits.

#### **⚠ CAUTION**

*Do not use gasoline or gasoline additives containing methanol because methanol can be corrosive to fuel system components*

*Do not use gasoline left over from the previous season to minimize gum deposits in the fuel system and to ensure easy starting. Do not add oil to the gasoline. Do not overfill the fuel tank. Leave room for the fuel to expand.*

*Do not add gasoline while the engine is hot or running. Do not start the engine near spilled gasoline. NEVER use gasoline as a cleaning agent.*

### Fuel Filter

The engine is equipped with an in-line fuel filter. Visually inspect the filter periodically and replace every 400 hours or when dirty.

## Oil

Use premium quality motor-oil. Look for the API (American Petroleum Institute) classification and use Class SG or SH oil (also SG/CD, SG/CE, SH/CD OR SH/CE). Also, look for the SAE (Society of Automotive Engineers) viscosity grade. Referring to the table below, choose the viscosity grade appropriate for the ambient temperatures expected during the period until the next scheduled oil change.

Single-grade SAE 30 oil is preferable when temperatures are consistently above freezing. Multi-grade oils are better when wide temperature variations are expected.

RECOMMENDED ENGINE OIL VISCOSITY		
TEMP. (°F)	RANGE	OIL TYPE
	-20° to 50°	5W30
	0° to 80°	10W30 or 10W40
	10° to 100°	15W40
	32° and UP	Single Grade 30

### CHECKING OIL



MAKE SURE THE ENGINE IS STOPPED AND PARKED ON A LEVEL SURFACE WHEN CHECKING OR ADDING OIL. ALSO, MAKE SURE THE ENGINE IS COOL AND THE OIL HAS HAD TIME TO DRAIN INTO THE SUMP.

Check oil BEFORE EACH USE as follows:

1. Clean the area around the fill tube to keep dirt and debris out of the engine.
2. Remove the oil fill cap/dipstick and wipe oil off. Reinsert the dipstick and push it all the way down into the tube.
3. Remove the dipstick and check the oil level. It should be within the crosshatch area.

### CHANGING OIL

For a new engine, change oil after the first 24 hours of operation, change oil every 100 operating hours thereafter.

It is recommended to change the oil while the engine is warm from operation.



MAKE SURE THE ENGINE IS STOPPED AND RESTING ON A LEVEL SURFACE.

Change oil as follows:

1. Place a pan under the vehicle below the drain plug to catch the used engine oil. Remove the oil drain plug and dipstick. Allow all the oil to drain out.
2. Reinstall the drain plug. Make sure it is tightened securely.
3. Replace the oil filter.
4. Fill with 1 quart of new oil (of the proper type). Always check the level on the dipstick before adding more oil.

## AIR CLEANER

This engine is equipped with a high-density air-cleaner element with an oiled- pre-cleaner that surrounds the paper element.

### Pre-Cleaner

If so equipped wash and re-oil the pre-cleaner every 50 operating hours (more often under extremely dusty or dirty conditions).

1. Rotate the quarter-turn fastener and remove the air cleaner cover.
2. Remove pre-cleaner from the paper element.
3. Rinse the pre-cleaner thoroughly until all traces of detergent are eliminated. Squeeze out excess water (DO NOT WRING). Air dry.
4. Saturate pre-cleaner in, clean fresh engine oil and squeeze out excess oil.
5. Reinstall pre-cleaner over paper element.

### Paper Element

Perform this procedure every 200 operating hours (more often under extremely dirty or dusty conditions).

1. Remove the pre-cleaner element cover and paper element.
2. Check the paper element. Replace the element as necessary.



DO NOT WASH OR USE PRESSURIZED AIR ON THE PAPER ELEMENT, AS IT WILL BE DAMAGED. IF DIRTY, BENT, OR DAMAGED REPLACE WITH A GENUINE ONAN ELEMENT. HANDLE ELEMENTS CAREFULLY. DO NOT USE IF SURFACES ARE BENT OR DAMAGED.

3. With the air cleaner disassembled check the base plate. Make sure it is secured and not bent or damaged. Also, check the element cover seals and breather tube for damage or improper fit. Replace all damaged components.

### ⚠ CAUTION

*Damaged or loose components could allow un-filtered air into the engine causing premature wear and failure.*

4. Reinstall the paper element cover and cover nut. Tighten the cover nut securely.
5. If so equipped install the pre-cleaner (washed and oiled) over the paper element.
6. Install air cleaner cover. Tighten quarter turn nut until it is snug against cover.

## IGNITION SYSTEM

### **▲ CAUTION**

*Do not apply 12-V DC to kill terminal of ignition module, as the module will burn out.*

No maintenance timing or adjustments are necessary or possible with this dependable electronic ignition system other than periodically checking or replacing the sparkplug. If starting problems occur which are not corrected by replacing the plug, refer to the engine manual for trouble analysis.

### **Spark Plug**

Perform this procedure every 400 operating hours.

1. Clean the area around the spark plug base to keep dirt and debris out of the engine.
2. Remove the plug and check its condition. Hard starting or engine misfire can be caused by a wrong plug, worn or fouled plug, cracked porcelain, or improper spark gap.
3. Replace the plug when dirty or if reuse is questionable. See "Engine Specifications Section 2, for plug type.

### **▲ CAUTION**

*Do not clean the spark plug in a machine using abrasive grit. Check spark gap (0.035) using a wire feeler gauge. Adjust the gap as necessary by carefully bending the ground electrode.*

4. Install the plug and torque to 20 ft lbs.

## SHIFTER CABLE

Over time the cables, which operate the forward/reverse, shift mechanism stretch and may eventually require adjustment to assure adequate gear management.

To check and adjust the shift cable, do the following:

1. Disconnect the ball joint at the transmission by sliding the outer sleeve towards the jam nut and then separating the ball joint from the receptacle.
2. Place the shift lever in the neutral position (in the detent).
3. Rotate the shift plate on the transmission so that it is halfway between forward and reverse.
4. Adjust the length of the shift cable (at the mounting bracket.) so that the ball joint receptacle can slide onto the ball joint without moving the shift plate.

### **⚠ CAUTION**

*Do not adjust the cable at the ball joint. It MUST be screwed in all the way.*

## BATTERY

### **▲WARNING**

***Battery electrolyte is poisonous and dangerous. It contains sulfuric acid . Avoid contact with skin eyes or clothing. Wear rubber gloves and safety glasses while servicing batteries. DO NOT INGEST!!***

***Batteries produce an explosive gas when charging. DO NOT SMOKE, produce an open flame or spark while checking or servicing a battery.***

### **Cleaning**

1. Dry dirt can be readily blown off with low-pressure air or brushed off.
2. Wetness or wet dirt on the covers indicates battery acid. Using a nonmetallic brush with flexible bristles wash it off with a strong solution of baking soda and hot water (1 lb. of soda to gallon of water). Continue until all fizzing stops, which indicates that the acid has been neutralized. Then rinse thoroughly with clear water. DO NOT get any of the solution into the battery cells.

### **Servicing**

1. Check the electrolyte level. If low fill with distilled water up to the correct level (see diagram).

### **▲CAUTION**

***Do not overfill the battery. An overfilled battery may leak acid.***

2. Clean the battery with water. Blow off excess water with compressed air.
3. Clean the cell posts connectors and steel tray with water.



## CHARGING

### ⚠ WARNING

***Explosive mixtures of hydrogen gas are present within battery cells at all times. Do not work with or charge battery in an area where open flames (including gas furnace or water heater pilots), sparks, cigarettes, or any other sources of combustion are present. Always provide ample ventilation in rooms where batteries are being charged.***

If the battery requires charging, do the following:

1. Check the electrolyte level. If low fill with distilled water up to, the correct level.
2. Charge the battery as necessary until the specific gravity of the electrolyte reaches 1.260 at 26.7C (80F).

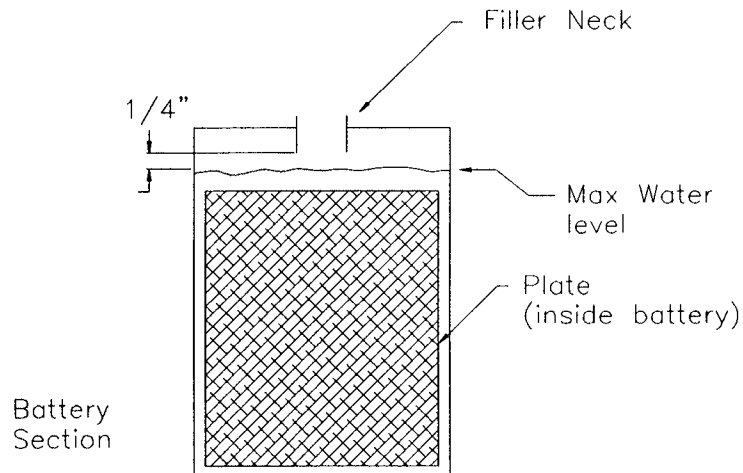

## Battery Storage

The following pointers will help extend the life of the battery when storing your vehicle for the winter season:

- ◆ Clean and check the electrolyte level and charge level of the battery. Do not store a battery low in electrolyte or in a low state of charge.
- ◆ Recharge a battery not in use every 1 to 2 months.
- ◆ If possible, store the battery in a cool dry place.

## TIRES

1. Check the tires for nicks or grooves and replace if necessary.
2. Ensure that the tire is properly seated on the rim.
3. Ensure that all the lug nuts are installed and secure.
4. Check the air pressure in the tires and inflate if necessary to the pressure specified.

## Tire Care

Refer to the chart below to determine the correct tire pressure for your needs.

### **⚠ CAUTION**

*Avoid over-inflating or under-inflating tires as both these conditions cause increased tire wear.*

## BRAKE SYSTEM

### ⚠ CAUTION

*Do not drive the vehicle if any worn or broken part is detected in any part of the brake system. The cause of the damage must be repaired immediately.*

The rear brakes are hydraulic drum brakes. They are manual adjusting type and will require periodic adjustment to assure safe operation and maximum brake life.

Servicing the rear brake assembly consists of:

- ◆ Adjusting the service brakes
- ◆ Replacing the brake drum and shoes
- ◆ Adjusting the parking brake

The front brakes are hydraulic discs. Hydraulic disk brakes are not adjustable and only require periodic inspection to insure that they are in good operating condition.

## Rear Brakes

Here we will cover how to service the rear brakes and all of their component parts.

### Adjusting The Rear Brakes

1. Raise the rear end and support it. .

### ⚠ WARNING

*Always use jack stands when supporting the vehicle.*

2. Remove the wheel and tire assembly.
3. Insert a brake-adjusting spoon into the adjusting slot in the brake drum and turn the star-adjusting nut until the brakes lock the wheel.
4. Now back off the star adjusting nut until the wheel spins freely with a minimum of drag.
5. Repeat steps 2 to 4 for the other side.
6. Lower the vehicle and test drive.



IF THE REAR BRAKES DO NOT BRAKE EVENLY THEN REPEAT STEPS 1- 6.

### Replacing the Brake Drum

It is recommended to replace drums as a set.

1. Raise the vehicle and support it.

#### **⚠ WARNING**

*Always use jack stands when supporting the vehicle.*

2. Remove the wheel and tire assembly.
3. Remove the brake drum.



If the drum is difficult to remove it may be necessary to back off the brake shoe adjustment before removing the brake drum. Make sure the new drum is clean and dry.

4. Install the new brake drum.
5. Adjust the brakes (both sides).
6. Install the wheel and tire assembly.
7. Remove the jack stands and lower the vehicle.
8. Test-drive the vehicle.

### Replacing the Brake Shoes

1. Raise the vehicle and support it.

#### **⚠ WARNING**

*Always use jack stands when supporting the vehicle.*

2. Remove the wheel and tire assembly.
3. Remove the brake drum.
4. Remove the brake shoe retracting springs.
5. Remove the hairpins from the mechanical actuating lever.
6. Remove the brake shoe hold down spring from each shoe. Remove the brake shoes and adjusting screw assembly.



WHEN REMOVING THE ADJUSTING SCREW ASSEMBLY, MAKE NOTE OF ITS ORIENTATION IN THE BRAKE ASSEMBLY.

7. Disassemble and clean the adjusting screw assembly.

8. Apply Hi-Temp grease to the adjusting screw assembly, the hold down and retracting spring contacts on the brake shoes and the torque spider contact points on the brake shoes.
9. Reassemble the brakes in reverse order.
10. Adjust the brakes
11. Install the wheels.
12. Lower and road test the vehicle.

## FRONT BRAKES

The front brake rotors are an integral part of the front hub. If the rotors are damaged or worn, the front hub must be replaced. Please refer to the maintenance guidelines on page 3-2, before beginning this or any service procedure.

## REPLACING THE BRAKE PADS

1. Raise the front end and support it.

### **▲WARNING**

*Always use jack stands when supporting the vehicle.*

2. Remove the front wheels.
3. Remove the two 1/4" caliper-retaining bolts.



AT THIS POINT, THERE IS NOTHING RETAINING THE BRAKE CYLINDER. DO NOT LET IT HANG BY THE BRAKES HOSE.

4. Inspect the spacers for wear and replace as necessary.
5. Replace the spacer bushings.
6. Re-assemble the brake using new brake pads.
7. Test drive

## Repairing the brake body

1. Remove the brake body.
2. Carefully remove the two pistons, rubber boots, and O-rings. (The pistons are very brittle and break easily.)
3. Clean and dry the brake body completely.



MAKE SURE THERE ARE NO CONTAMINANTS LEFT IN THE BRAKE BODY.

4. Inspect the interior of the brake body. If any damage or wear is found it must be replaced.
5. Re-assemble the brake body using clean DOT 5-brake fluid as a lubricant.

Use tool #41-350-13 to install the rubber boots

6. Install the brake body.



THE 1/4" GR. 8 LOCKNUTS FOR THE CALIPER BOLTS MUST BE REPLACED.

7. Bleed the brakes.
8. Test drive.



## PARKING BRAKE

In this section, we will cover how to properly adjust the parking brake. Please refer to the maintenance guidelines on page 3-2, before beginning this or any service procedure.

### Primary adjustment

1. Block the wheels.
2. Release the parking brake
3. Turn the parking brake handle to adjust.
4. The brake should be adjusted to hold firmly but with no drag when released.

### Secondary adjustment



YOU MUST ADJUST THE REAR BRAKES BEFORE PERFORMING THIS ADJUSTMENT.

1. Block the wheels.
2. Release the parking brake.
3. Back off the primary adjustment (previous section).
4. Loosen the two jam nuts on the turn buckle assembly at the equalizer.
5. Turn the turn buckle assembly until the brake cables are snug with no brake drag.
6. Tighten the two jam nuts.



IT WILL BE NECESSARY TO READJUST THE PRIMARY PARKING BRAKE ADJUSTMENT.

### Parking Brake Cables

Visually inspect the brake cables for signs of wear or cracks. Visually inspect the end connections for broken wire strands.

Replace any worn or damaged cables immediately.

## FRONT AXLE AND STEERING

Your front axle and wheel assembly consists of an axle mounted on two- (2) leaf-springs, with automotive spindles, steering worm, and steering linkage.

Zerk type grease fittings have been provided to ensure proper amounts of lubricant reaching wear points.

The maintenance manual is set up for average vehicle use. For heavier use, lubrication and service should be more frequent.

The steering worm gear box and steering linkage is similar to those used on automobiles.

### Aligning the Front End/Adjusting Toe-in



Caster and camber are set at the factory and do not require adjustment.

1. Raise the front end of the vehicle and support with jack stands.
2. Center the steering.
3. With a piece of chalk, mark a line around the center of both of tires by holding the chalk against the tire while turning the wheel.
4. Loosen tie rod sleeve clamps at each end of tie rod so the adjusting sleeve can be turned.
5. With wheels in straightforward direction measure the distance between chalk lines at the front and the rear of the tires.

## Removing and Installing The Wheel Hubs

1. Remove tire/wheel assembly.
2. Remove dust cap.
3. Remove cotter pin and unscrew spindle nut, outer washer, bearing and hub assembly.
4. Thoroughly clean the bearings spindle and hub assembly.
5. Inspect bearings, races and seal for wear or damage. Replace damaged or worn parts.
6. Generously pack bearings with wheel bearing grease.
7. Re-assemble in reverse order.
8. Tighten spindle nut to 30-ft lbs. to seat bearings.
9. Back off the spindle nut to the next slot on the nut and install the new cotter pin.
10. Install the dust cap and tire/wheel assembly.

## Adjusting Front Wheel Bearings

1. Remove the bearing dust cap.
2. Refer to steps 8 through 10 in previous section.

## KING PINS AND BUSHINGS

Here we will go over how to remove and install the king pins and their bushings.

### Removing King Pins and Bushings

1. Remove the tire/wheel assembly.
2. Remove the kingpin locknut.
3. Remove the kingpin from the axle.
4. Press bushings from the axle. *(If required.)*
5. Thoroughly clean the bushing housing and kingpin before installing new bushings.

### Installing King Pins and Bushings

1. Inspect the king pins. If any damage, or wear marks, is apparent, they should be replaced.
2. Reassemble in reverse order. Lightly grease the kingpin and seat into place in the yoke.
3. Install new lock nut and tighten snug against lower yoke plate.

### **⚠ WARNING**

***DO NOT DRAW THE YOKE PLATES TOGETHER!***

## **BALL JOINTS**

Now we will go over the proper way to remove and install the ball joints.

### **Removing Ball Joints**

1. Remove cotter pin and nut from ball joint.
2. Loosen the clamp on the tie rod.
3. Remove the ball joint from the steering arm with a pickle fork.
4. Unscrew the ball joint from the steering sleeve. (Count the turns required to remove the ball joint.)

### **Installing Ball Joints**

1. Install the new ball joint and position the same way as the one removed. Screw in to tie rod the same number of turns as noted above.
2. Tighten ball joint nut to 40-45 ft lbs.
3. Re-align front wheels.
4. Tighten sleeve clamp(s) securely.
5. Grease the new ball joint(s). Refer to the Lubrication Chart in Section 3.

## STEERING WORM ASSEMBLY

It is very important to know how to service the worm gear assembly in the steering gear. Here we will cover how to remove and install the worm gear.

### Removing the Steering Worm

1. Remove the cover from the steering column and turn the steering wheel until the nut and bolt on the steering shaft is visible.
2. Loosen the nut and bolt holding the steering shaft clamp onto the input shaft of the steering worm (gear.)
3. Remove the pitman arm.
4. Remove the three- (3) mounting bolts at the bottom of the steering assembly and lower the steering gear out of the column.

### Installing the Steering Worm

1. Install the steering gear in reverse order.
2. Align the front wheels straight ahead.
3. Install the steering wheel loosely.
4. Center the steering gear.
5. Install the steering arm while keeping the front wheels in the straight-ahead position. Tighten nut to 70-ft lbs.
6. Remove and center the steering wheel on the steering shaft while keeping the front wheels in the straight-ahead position.
7. Install the steering wheel nut and cap.

## STEERING LUBE

The G 1-50 uses grease rather than oil to lubricate the steering gearbox. All that is required is the once-a-year check of the quantity and quality of the grease.

1. Remove the steering box cover.
2. If the grease supply is low, add or replenish the gearbox with multi-purpose (chassis) type grease.



IF THE GREASE IN THE GEARBOX IS CONTAMINATED, IT MUST BE CLEANED OUT AND REPACKED.

3. Reinstall the steering gear box cover.
4. Adjust the tie rod sleeve until the distance from mark to mark across the front of the tires is the same as the distance from mark to mark across the rear.
5. Tighten the adjusting sleeve clamp nuts securely.

## DRIVE ASSEMBLY

Here we will cover how to remove and install the drive belt, primary sheaves, and the secondary sheaves.

### **▲WARNING**

*Disconnect both battery leads to prevent accidental engagement of power while servicing the vehicle.*

### Removing the Drive Belt

1. Block front wheels and place the shifter in neutral.
2. Pull up on the belt at the same time pulling it over the outside edge of the secondary sheave.
3. Rotate the secondary sheave counter clockwise to roll the belt off the secondary sheave.
4. Slip the belt over the primary sheave for complete belt removal.
5. Inspect the drive belt for wear and damage. Minimum belt width is 1.06".

### Installing the Drive Belt

1. Pry open the secondary sheave and insert a small block to hold it open.



SOME PARTS OF THE SHEAVE ARE ALUMINUM. BE CAREFUL NOT TO DAMAGE THEM.

2. Slip the belt over and around the primary sheave.
3. Pull the belt around the secondary sheave and remove the block from step 1.



## REMOVAL PRIMARY SHEAVE

1. Block front wheels and place shifter in neutral.
2. Remove the drive belt.
3. Remove parking brake cables and hydraulic brake hoses.
4. Remove upper shock bolts.
5. Disconnect traction bar from swing arm.
6. Disconnect the exhaust flex pipe from the muffler.
7. Disconnect engine wiring.
8. Remove shift cable ties from frame. You do not need to remove the cable.
9. Raise rear of frame to provide enough clearance to remove the sheave.
10. Remove the sheave mounting bolt, lock washer, heavy-duty flat washer and cap washer.

### **⚠ CAUTION**

*Hoist frame to clear sheave only. If it is raised to far other components may be damaged.*

11. Remove the sheave mounting bolt lock washer heavy-duty flat washer and cap washer.
12. Remove primary sheave assembly.



THERE ARE NO INTERNALLY SERVICEABLE PARTS IN THE PRIMARY SHEAVE. IF IT IS DEFECTIVE, IT MUST BE REPLACED AS AN ASSEMBLY.

## Installation Primary Sheave

13. Lube the engine output shaft with grease.
14. Install in reverse order

## Removal Secondary Sheave

1. Remove the drive belt.
2. Remove the secondary sheave mounting bolt, lock washer, and heavy-duty flat washer.
3. Remove the left rear shock.
4. Remove the secondary sheave.
5. Inspect ramp shoes and replace as necessary.



THERE ARE NO OTHER SERVICEABLE PARTS IN THE SECONDARY SHEAVE. IF IT IS DEFECTIVE, IT MUST BE REPLACED AS AN ASSEMBLY.

## Installation Secondary Sheave

1. Lube the transmission-input shaft with grease.
2. Install in reverse order.

## THROTTLE CABLE ADJUSTMENTS

A correctly adjusted cable operates as follows:

- ◆ When the pedal is depressed completely there should be a 1/32" gap between the throttle arm and the throttle stop on the engine.
- ◆ When the cable is released, it should not push on the throttle arm.
- ◆ The throttle arm should start to move at the same time the pedal is depressed.

To adjust the throttle cable follow the procedure below:

1. Adjust the pedal stop bolt to give maximum travel.
2. Clamp the cable near the end of the cable sleeve (at the accelerator).
3. Depress the pedal completely.
4. Adjust the cable length at the engine so that the throttle arm is 1/32" from the stop (on the engine).
5. Tighten the cable clamp (at the engine).
6. Release the pedal.
7. Adjust the pedal stop screw to eliminate any excessive travel.
8. Tighten the pedal stop screw jam nut.

## REMOVING AND INSTALLING THE TRANSMISSION

1. Remove both rear wheels.
2. Remove the drive belt.
3. Remove the secondary sheave.
4. Remove the shift cable arm
5. Remove the parking brake cables and hydraulic brake lines from the rear brakes.
6. Remove upper shock bolts.
7. Remove the four- (4) U-bolts mounting the rear axle tubes to the swing arm.
8. Hoist up the rear of the frame to provide clearance to remove the transmission.

### **▲ CAUTION**

*Hoist frame to clear transmission only. If it is raised to far other components may be damaged.*

9. Remove transmission from frame.

## Installing the Rear Axle

1. Install in reverse order.
2. Bleed the brakes.



FOR REAR AXLE TRANSMISSION SERVICING REFER TO DANA DRIVE MANUAL, M7-001-04 (ATTACHED.)

## REMOVING AND INSTALLING THE ENGINE

1. Disconnect the battery cables from the battery.
2. Remove the drive belt.
3. Disconnect the throttle linkage.
4. Unplug the engine harness, disconnect the wires from the starter solenoid.
5. Remove the four screws from the muffler header (00-610-32).
6. Disconnect and plug the fuel line.

### **▲CAUTION**

*Some fuel may leak from the fuel line when it is disconnected.*

7. Remove the four lower engine-mounting bolts
8. Hoist the engine out.
9. Install in reverse order.

For engine servicing, refer to the Onan Engine Manual, M7-001-03 (attached).

## STORING AND RETURNING CARS TO SERVICE

### STORING CARS

If the vehicle will be out of service for two months or more use the following storage procedure:

1. Change oil when the engine is still warm from operation.
2. Drain the fuel tank and fuel system (or run the engine until the fuel tank and fuel system is empty).
3. Remove the spark plug and pour one-tablespoon of motor oil into the hole. Install the plug but do not connect spark plug lead. Crank the engine two or three revolutions.
4. Turn engine over by hand until the piston is at the top of its stroke. Leave the spark plug disconnected.
5. Clean exterior surfaces of the engine. Spread a light film of oil over any exposed metal surfaces of the engine to prevent rust.
6. Charge the battery (see "Battery" this section).
7. Protect the tires from moisture, oil, and ozone (such as is found in the battery charging area).
8. Lift the body off the tires, and clean and dry the chassis.



AVOID STORING IN HUMID AREAS TO PREVENT RUST AND CORROSION.

### RETURNING CARS TO SERVICE

The following steps must be taken to properly return a car to service after storage.

1. Readjust the tire pressure to specifications.
2. With the key turned off check the operation of the brakes parking brake accelerator steering mechanism and choke.
3. Re-connect the spark plug. Start and run the engine for a brief period.
4. Operate the car for a short distance to note any problems with the items listed in step 2.
5. Clean and wash the car before returning it to service.

## NEW TRANSMISSION/DRIVE

In vehicles with serial numbers greater than 127633 a newer style Dana Drive has been installed. This newer drive can be installed in vehicles that currently have the older drive part number 4C-610-00, See *"Installing New Drive in Older Vehicles."*

All of the procedures for working on the transmission or drive contained in this manual are the same regardless of the type of drive currently in your vehicle. Refer to page 4-36 and 4-37 for a figure and parts list for the new drive.

### Identifying Your Drive

If you are not sure which drive is in your vehicle, use the following tips.

1. Check the serial number if it is greater than or equal to 127633, then you have the newer drive installed in your vehicle.
2. If the rear of the drive has a cover with the fill plug on the left side, it is the old style drive.
3. If the rear of the drive case is split in half then you have a new style drive.

### Changing the Drive Oil

The manufactures of this drive do not recommend that the oil in this drive be drained or refilled. Unless the drive has been overhauled or there is a leak.

#### **▲CAUTION**

*Use only synthetic gear oil in this drive.*

## **Installing New Drive in Older vehicles**

There are a couple of modifications which must be made in order to install the new drive part number 4C-610-20 into those vehicles which currently have the older drive part number 4C-610-00 installed in it. As of the time of printing, the kit for installing this new drive in older vehicles had not been completed. Please call your local TAYLOR-DUNN<sup>®</sup> representative for information about installing the new drive in older vehicles.



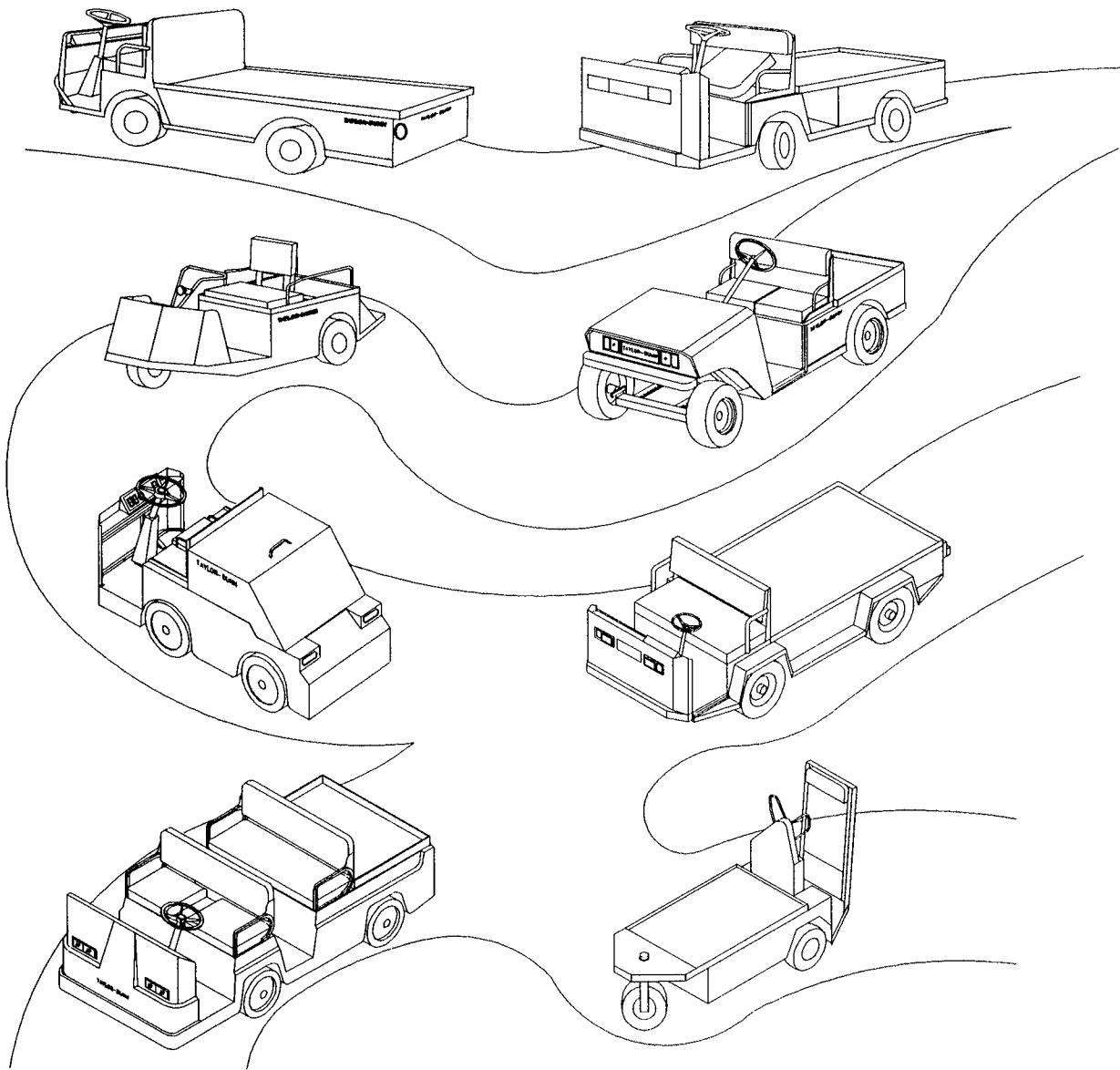

***You're in great company with  
Taylor-Dunn<sup>®</sup>***

# SECTION 4

# ILLUSTRATED PARTS

# LIST

G1-50

# FRONT AXLE

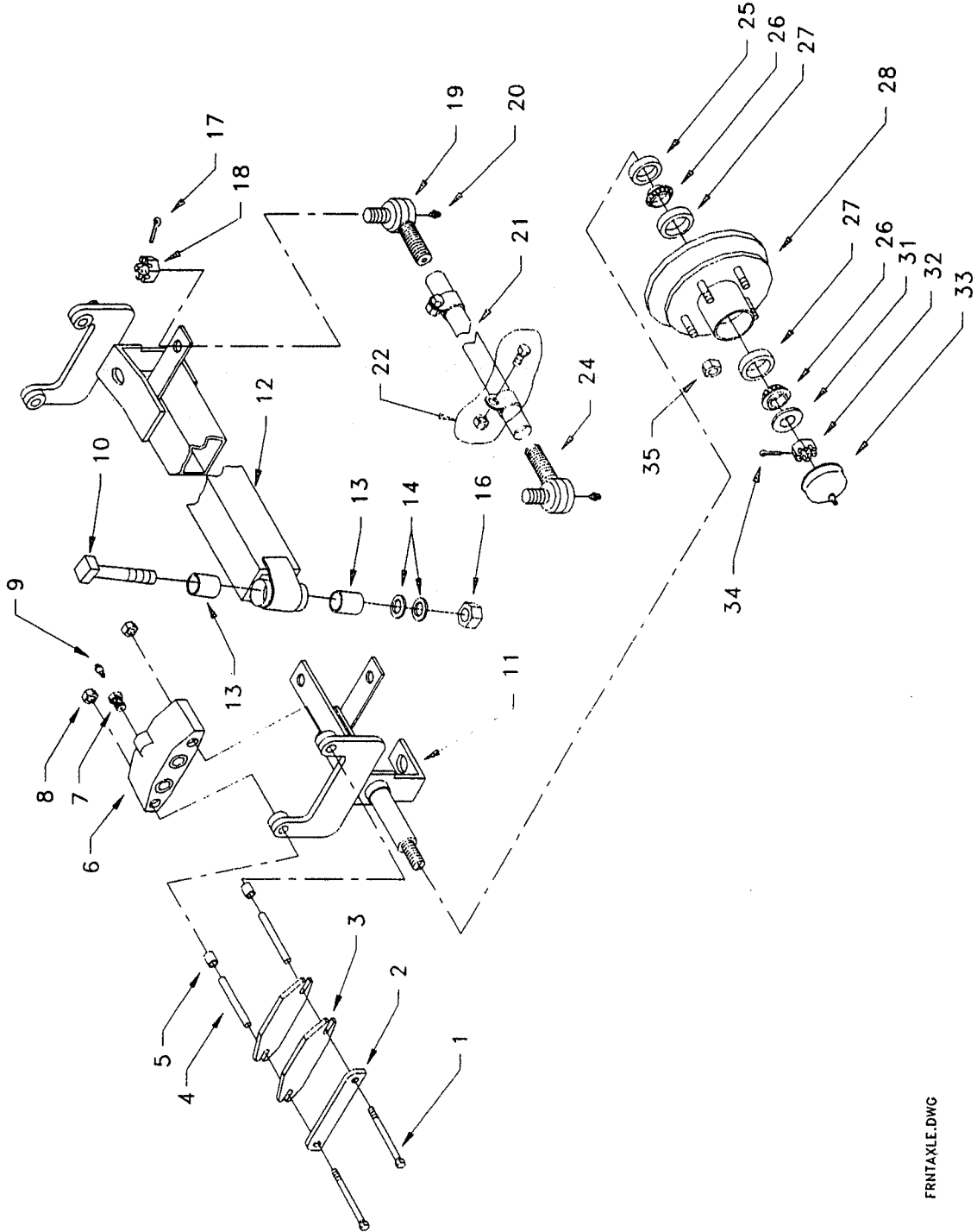

FRONT AXLE			
Item #	Part #	Description	QTY
1	88-067-21	Brake body bolt (grade 8)	4
2	41-350-51	Brake pad backing plate	2
3	41-348-70	Brake pad	4
4	41-348-52	Spacer	4
5	32-240-40	Bushing	4
6	41-350-70	Brake body (Rebuild kit 41-350-66)	2
7	99-588-01	Brake bleeder fitting	2
8	88-069-82	Brake body nut (grade 8,)	4
9	99-588-00	Brake bleeder valve	2
10	21-020-15	King pin	2
11	14-210-88	Left (driver) side steering yoke	1
11	14-210-89	Right (passenger) steering yoke	1
12	15-210-00	Front axle weldment	1
13	32-240-55	Upper/lower king pin bushing	2
14	97-180-55	Thrust washer	4
16	88-189-81	King pin nut	2
17	88-527-11	1/8 x 1 cotter pin	2
18	88-159-85	Ball joint nut	2
19	86-501-99	Ball joint (right thread)	1
20	87-074-00	Grease fitting	2
21	18-041-00	Tie rod	1
22	86-510-00	Ball joint clamp w/nut and bolt	2
24	86-501-98	Ball joint (left thread)	1
25	45-338-00	Grease seal	2
26	80-017-00	Inner/Outer wheel bearing	4
27	80-103-00	Inner/Outer race	4
28	12-158-10	Front hub (w/rotor),	2
31	88-228-61	3/4 SAE flat washer	2
32	88-239-85	Wheel bearing nut	2
33	92-104-00	Wheel bearing cap	2
34	88-527-11	Cotter pin	2
35	97-236-00	Wheel nut	10

# FRONT SUSPENSION

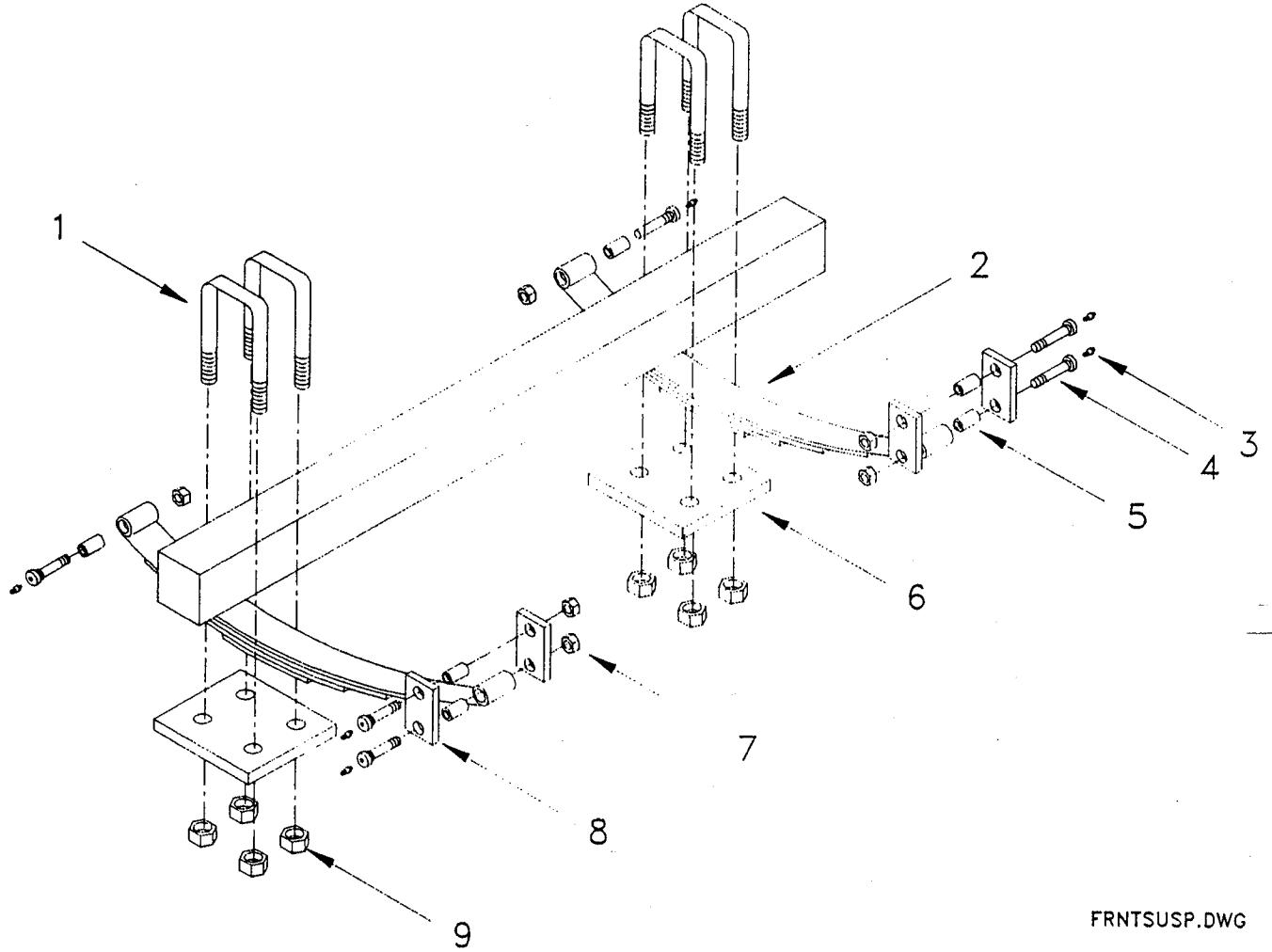

FRNTSUSP.DWG

FRONT SUSPENSION			
Item #	Part #	Description	QTY
1	96-123-00	U-Bolt	4
2	85-512-10	Leaf Spring	2
3	87-074-00	Grease fitting	6
4	96-248-01	Shackle bolt	6
5	32-213-00	Nylon bushing	6
6	16-865-02	Spring plate	2
7	88-169-82	9/16 NF lock nut	6
8	16-870-10	Spring shackle	4
9	88-109-81	3/8 NC lock nut	8
Not shown	10-081-00	Tire, 570 x 8, LR B	2
	10-086-00	Tire, 500 x 8 soft-solid (optional)	2
	92-000-00	Wheel cover, drop center (optional)	2
	92-002-00	Wheel cover, split rim (optional)	2

## STEERING GEAR

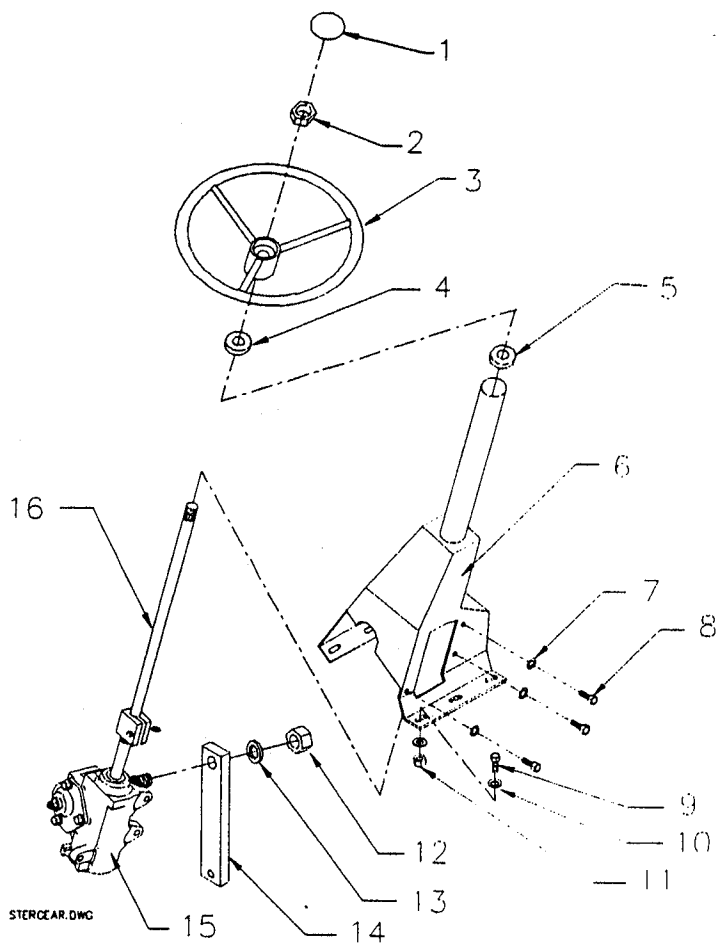

## DRAG LINK

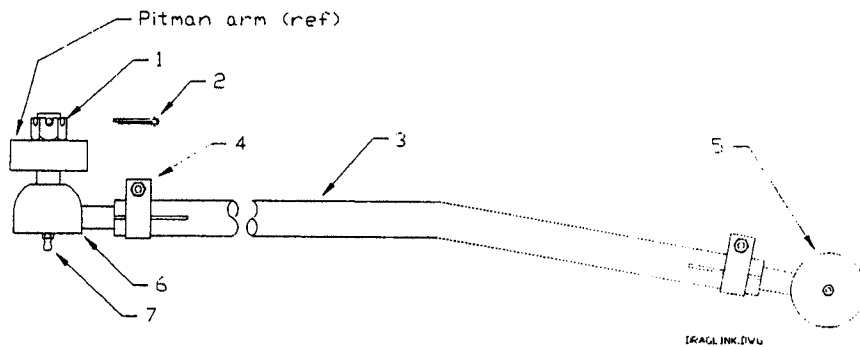

STEERING GEAR			
ITEM #	PART #	DESCRIPTION	QTY
1	19-011-25	Steering wheel cap	1
2	88-159-82	1/2 NF jam nut	1
3	19-011-20	Steering wheel	1
4	97-200-00	Dust washer	1
5	80-400-10	Upper steering shaft bushing	1
6	00-210-17	Steering column	1
7	88-128-62	7/16 split lock washer	3
8	88-120-11	7/16 x 1 NC hex bolt	3
9	88-100-11	3/8 x 1 NC hex bolt	6
10	88-108-61	3/8 SAE flat washer	12
11	88-109-81	3/8 NC lock nut	6
12	88-279-82	7/8 NF jam nut	1
13	88-268-62	7/8 split lock washer	1
14	18-111-30	Pitman arm	1
15	18-308-21	Steering gear	1
16	20-031-43	Steering shaft (Note: Must also purchase 88-081-14 (Bolt) & 88-089-84 (Nut) separately.)	1
DRAG LINK			
1	88-159-85	Castle nut	2
2	88-527-11	Cotter pin	2
3	18-057-10	Drag link	1
4	86-510-00	Ball joint clamp	2
5	86-501-99	Ball joint w/grease fitting (RH)	1
6	86-501-98	Ball joint w/grease fitting (LH)	1
7	87-074-00	Grease fitting	2



# PARKING BRAKE LINKAGE

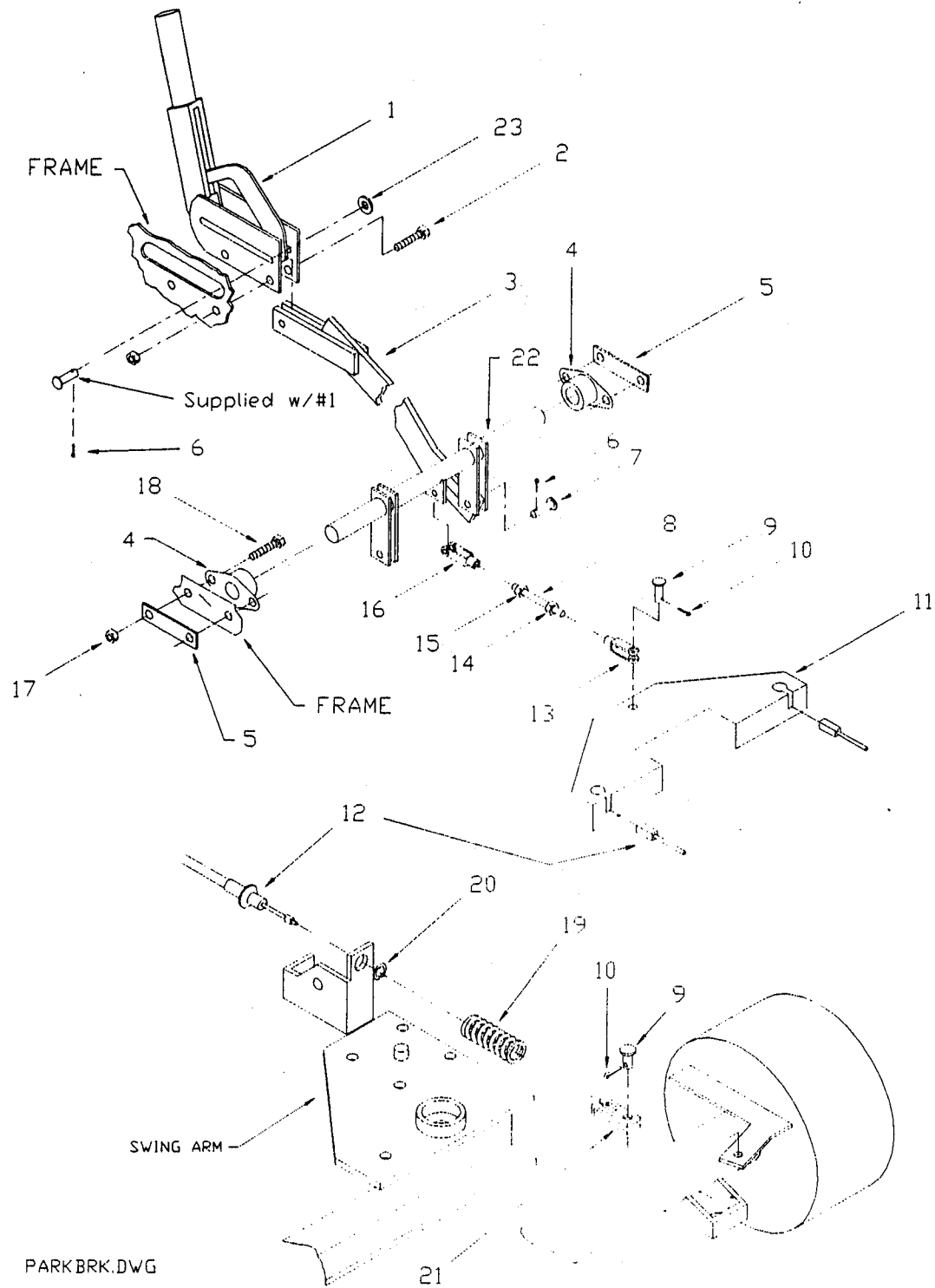

PARKING BRAKE LINKAGE			
ITEM #	PART #	DESCRIPTION	QTY
1	51-340-30	parking brake lever	1
2	88-100-15	3/8 x 1-3/4 NC hex bolt	2
3	00-610-20	Parking brake linkage weldment	1
4	80-410-20	3/8 NF hex nut	1
5	02-610-25	Bearing cover plate	2
6	88-517-09	3/32 x 3/4 Cotter pin	4
7	96-772-00	3/8 x 1 Clevis pin	2
8	96-343-00	Adjusting link	1
9	96-773-00	5/16 x 1 Clevis pin	4
10	88-527-11	1/8 x 1 Cotter pin	3
11	02-610-23	Equalizer	1
12	96-826-12	Parking brake cable	2
13	96-763-00	5/16 Clevis	1
14	88-099-80	5/16 NF hex nut	1
15	88-099-81	5/16 NF hex nut (left thread)	1
16	96-765-00	5/16 Clevis (left thread)	1
17	88-109-81	3/8 NC lock nut	4
18	88-100-09	3/8 x 3/4 NC hex bolt	1
19	85-126-00	Spring	2
20	88-847-08	Retainer ring	2
21	96-762-00	Brake cable clevis	2
22	00-610-15	Cross shaft	1
23	88-088-61	5/16 SAE flat washer	1

# FOOT BRAKE LINKAGE

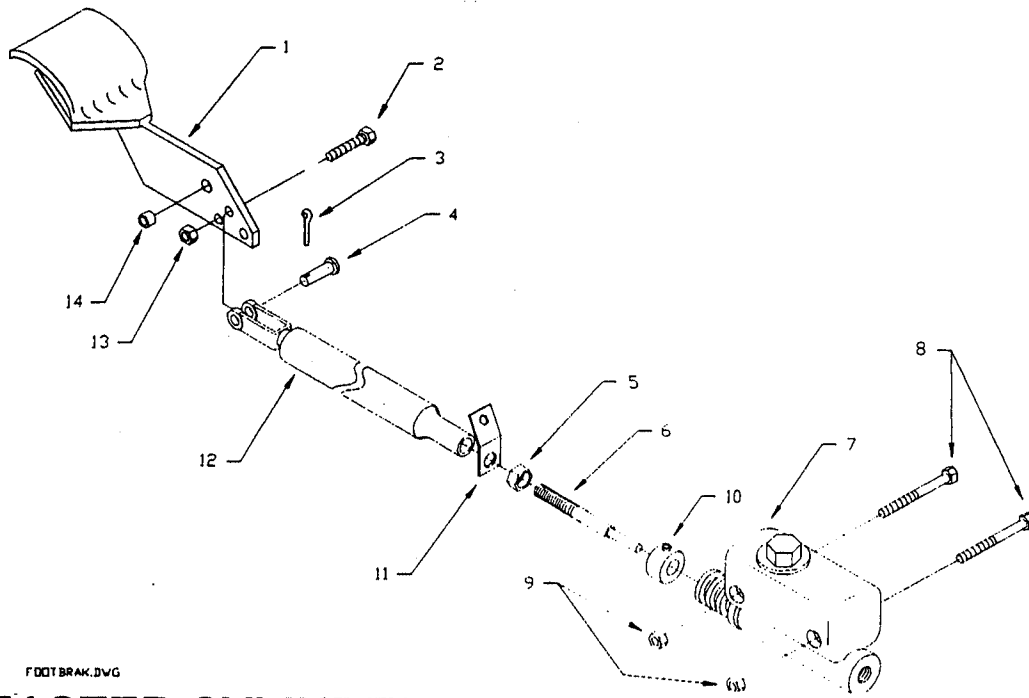

FOOTBRAK.DWG

# MASTER CYLINDER

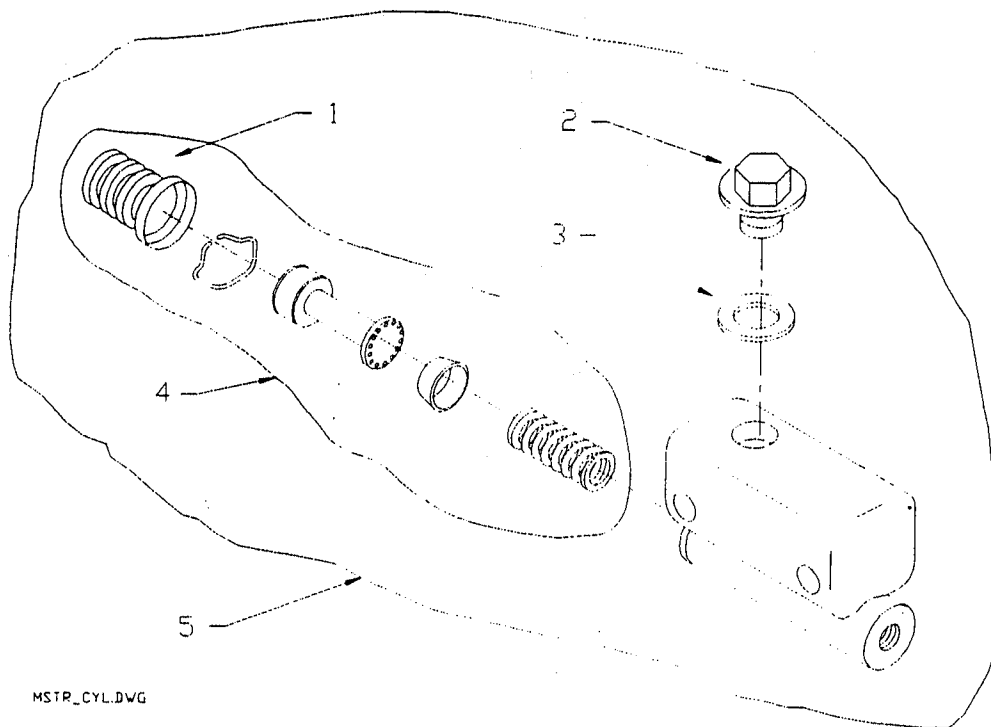

MSTR\_CYL.DWG

FOOT BRAKE LINKAGE			
ITEM #	PART #	DESCRIPTION	QTY
1	05-210-97	Brake pedal	1
2	88-100-11	3/8 X 1 NC Hex Bolt	1
3	85-517-09	Cotter Pin	1
4	96-772-00	Clevis Pin	1
5	88-119-80	3/8 NF Hex Bolt	1
6	50-009-00	Push Rod	1
7	99-510-02	Master Cylinder Assembly	1
8	88-101-20	3/8 X 3 Grade 5 Hex Bolt	2
9	88-109-81	3/8 NC Locknut	2
10	17-104-00	Collar	1
11	06-210-03	Return Spring Mounting Clip	1
12	06-210-08	Push Rod	1
13	88-109-81	3/8 NC Locknut	1
14	32-240-40	Bushing	1
MASTER CYLINDER			
1	99-510-51	Boot	1
2	99-510-52	Cap	1
3	99-510-53	Gasket	1
4	99-510-61	Rebuild Kit	1
5	99-510-01	Master Cylinder Assembly	1

85-233-00 Brake pedal return spring

# REAR BRAKES

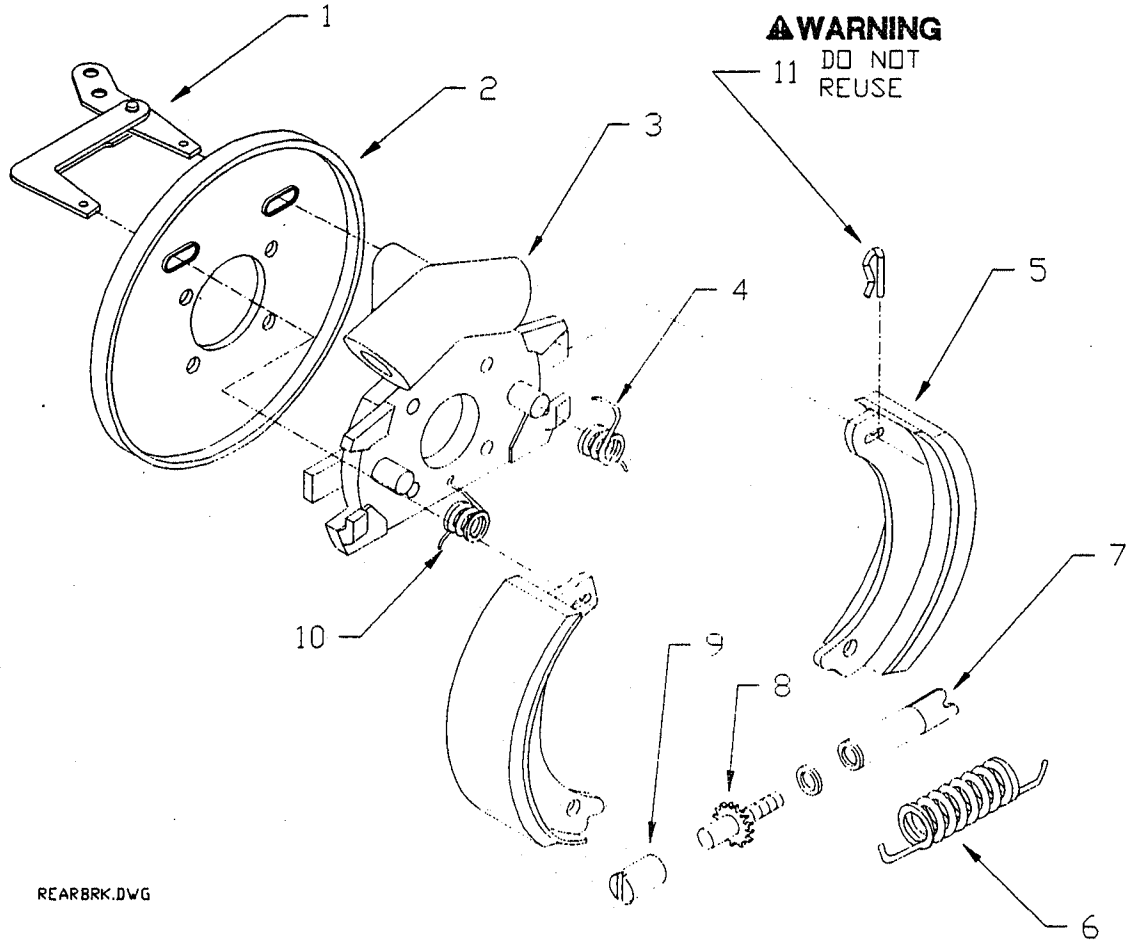

REAR BRAKES			
ITEM #	PART #	DESCRIPTION	QTY
1	41-347-15	Parking brake actuator	2
2	41-347-00	Backing plate	2
3	41-347-27	Spider, w/wheel cylinder	2
4	85-411-10	Torsion spring (green)	2
5	41-635-00	Brake shoes	2
6	85-215-00	Spring	2
7	41-347-33	Adjustment body	2
8	41-347-31	Star wheel adjuster	2
9	41-347-30	Socket	2
10	85-411-15	Torsion spring (red)	2
11	41-347-34	Parking brake actuator-retaining clip. DO NOT REUSE!	4

99-507-00 Repair  
 41-516-00 Drum  
 41-347-28 Rear Left Hydraulic Brake Assy  
 41-347-29 Rear Right Hydraulic Brake Assy

# BRAKE LINES AND HOSES

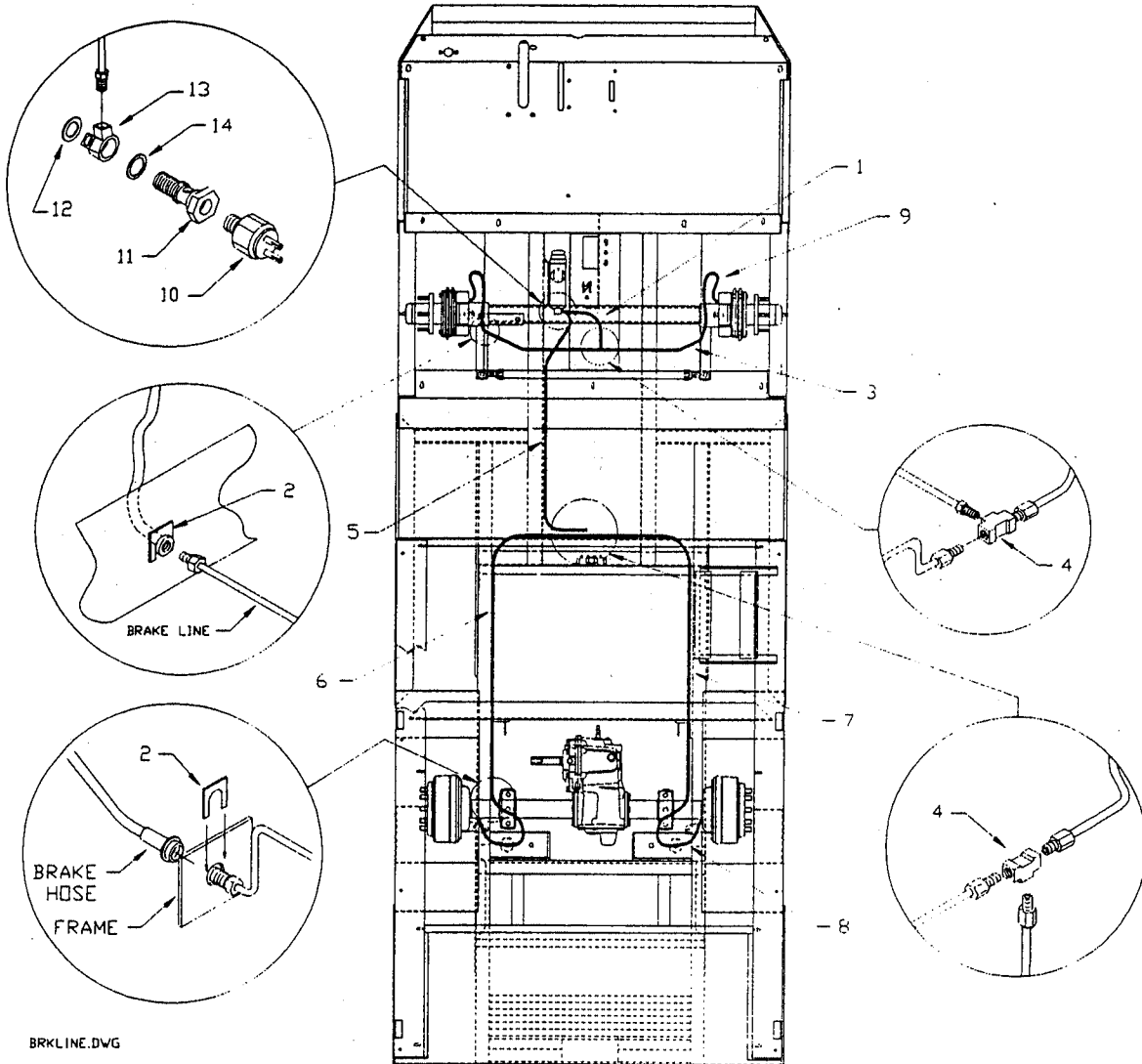

BRAKE LINES AND HOSES			
ITEM #	PART #	DESCRIPTION	QTY
1	99-603-54	Brake line	1
2	99-576-00	Hose retaining clip	4
3	99-603-53	Brake line, front	2
4	99-564-00	T-Union	2
5	99-607-51	Brake line	1
6	99-605-55	Brake line, left rear	1
7	99-605-56	Brake line, right rear	1
8	99-580-10	Rear brake hose	2
9	99-580-20	Front brake hose	2
10	71-110-00	Brake light switch	1
11	99-578-00	Master cylinder fitting	1
12	99-572-00	Copper washer	1
13	99-565-00	Y-Fitting	1
14	99-571-00	Copper washer	1



# ACCELERATOR PEDAL LINKAGE

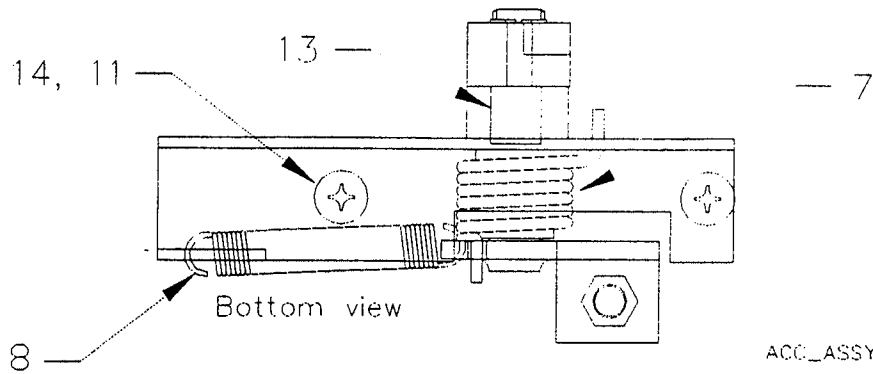
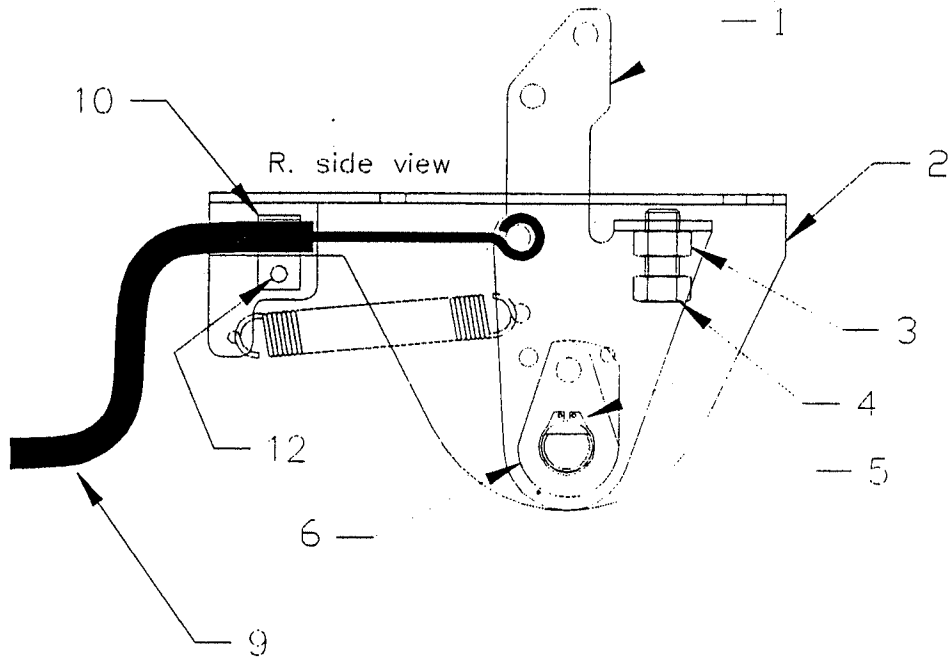
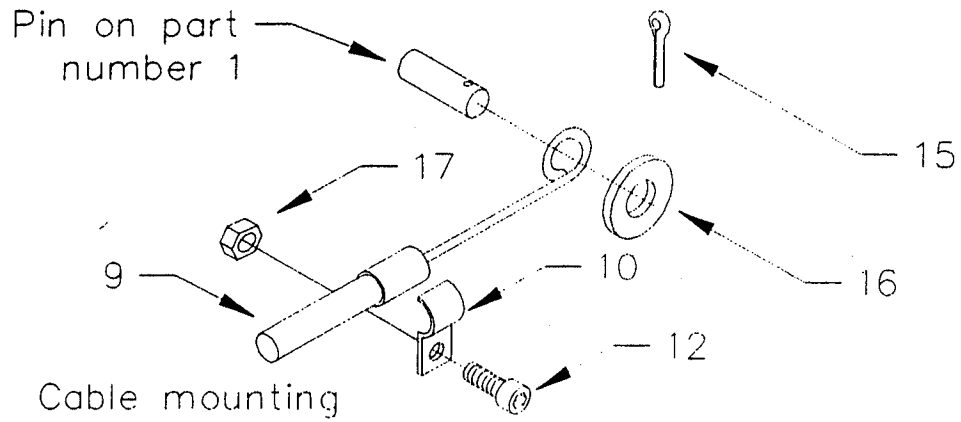

ACC\_ASSY.DWG

ACCELERATOR PEDAL LINKAGE			
ITEM #	PART #	DESCRIPTION	QTY
1	62-037-03	Rotor	1
2	62-033-16	Mounting bracket w/bushings	1
3	88-119-80	3/8 NF hex nut	1
4	88-110-09	3/8 x 3/4 NF hex bolt (gr. 5)	1
5	88-840-08	Circlip	1
6	62-033-06	Cam	1
7	85-352-38	Return spring (torsion)	1
8	85-209-09	Return spring (extension)	1
9	96-872-01 <del>61</del>	Throttle cable	1
10	96-871-01	Clamp	1
11	88-069-81	1/4 NC lock nut (not pictured)	2
12	88-025-05	8-32 Socket head machine Screw	1
13	32-215-50	Bushing	2
14	88-065-06	1/4 x 1/2 Truss head screw	2
15	88-517-11	Cotter pin	1
16	88-068-61	1/4 SAE Flat washer	1
17	88-029-86	8-32 Lock nut	1
NOT SHOWN	98-254-10	Accel. pedal	1
NOT SHOWN	88-065-09	Accel. pedal mounting bolts	2
NOT SHOWN	88-069-81	Accel. pedal mounting nuts	2
	62-037-02	Complete accelerator assembly (less cable and hardware)	1

SECTION 4

ILLUSTRATED PARTS LIST



# SHIFTING LINKAGE (For Serial #'s Before 127633)

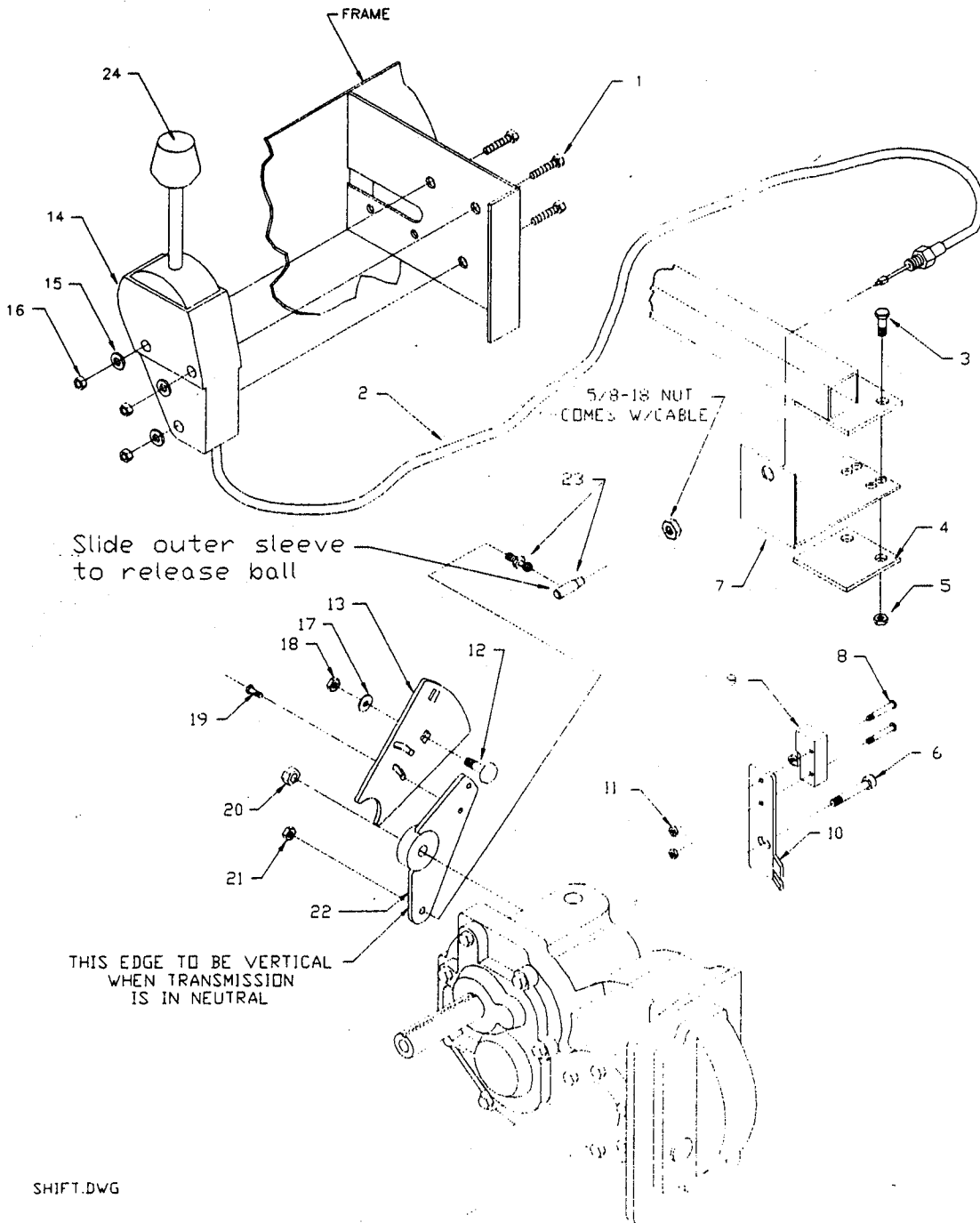

SHIFTING LINKAGE			
ITEM #	PART #	DESCRIPTION	QTY
1	88-080-18	5/16 x 2-1/2 hex bolt	3
2	96-851-00	Shift cable	1
3	88-080-11	5/16 x 1 hex bolt	1
4	00-610-26	Spacer	1
5	88-089-81	5/16 Lock nut	1
6	88-107-08	3/8 x 5/8 NF Socket head bolt	1
7	00-610-25	Mounting bracket	1
8	88-014-13	6-32 x 1-1/4 machine screw	2
9	71-130-01	Neutral start switch	1
10	00-610-34	Neutral switch bracket	1
11	88-019-86	6-32 Lock nut	2
12	88-102-09	3/8 x 3/4 NC Carriage bolt	1
13	02-610-40	Neutral switch trigger arm	1
14	96-853-10	Shift quadrant	1
15	88-088-61	5/16 SAE washer	3
16	88-089-81	5/16 NC Lock nut	3
17	88-108-65	3/8 Cut washer	1
18	88-109-80	3/8 NC hex nut	1
19	88-047-09	10-32 x 3/4 Machine screw	1
20	89-089-81	5/16 NC lock nut	1
21	88-079-80	1/4 NF hex nut	1
22	00-610-31	Shift lever	1
23	96-852-00	Shift cable rod end	1
24	94-306-07	"Push to shift" decal	1

# ENGINE MOUNT (Serial #'s Before 127633)

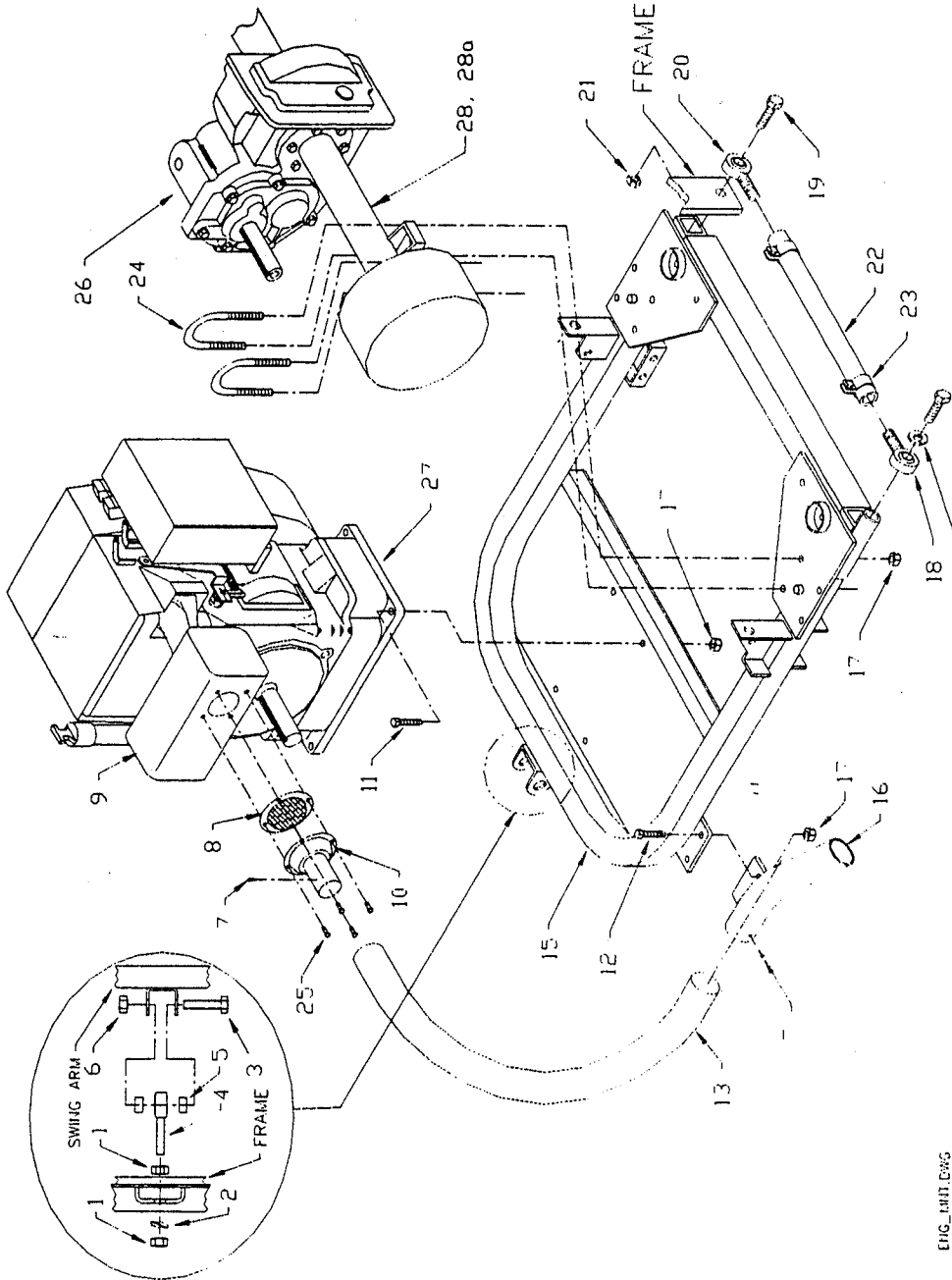

ENG\_MOUNT.DWG

ENGINE MOUNT			
ITEM #	PART #	DESCRIPTION	QTY
1	88-239-80	3/4 NF hex nut	1
2	88-229-62	3/4 split lock washer	1
3	88-220-22	3/4 x 3 1/2 Hex bolt	1
4	86-523-99	Front engine mount	1
5	16-406-00	Spacer, 7/16	2
6	88-229-81	3/4 NC lock nut	1
7	88-828-09	#10 x 3/4 sheet metal screw	1
8	66-400-20	Spark arrester	1
9	66-400-10	Muffler	1
10	00-610-32	Exhaust extension adapter	1
11	88-101-13	3/8 x 1 1/4 Hex screw (grade 5)	4
12	88-100-11	3/8 x 1 Hex screw	2
13	66-400-46	Exhaust extension	1
14	88-188-62	5/8 Split lock washer	1
15	00-610-22	Swing arm	1
16	00-610-17	Tail pipe	1
17	88-109-81	3/8 NC lock nut	13
18	86-521-98	Rod end (LH)	1
19	88-180-15	5/8 x 1 3/4 NC hex bolt	2
20	86-521-99	Rod end (RH)	1
21	88-189-81	5/8 NC lock nut	1
22	41-402-00	Traction bar	1
23	86-510-00	Clamp	2
24	96-123-50	U-Bolt	4
25	88-817-06	Extension adapter screw	4
26	4C-610-00	Transmission assembly. (w/brakes)	1
27	67-001-00	Engine assembly	1
28	41-127-62	Axle, Left, Dana Drive	1
28a	41-127-63	Axle, Right, Dana Drive	1

# CVT DRIVE

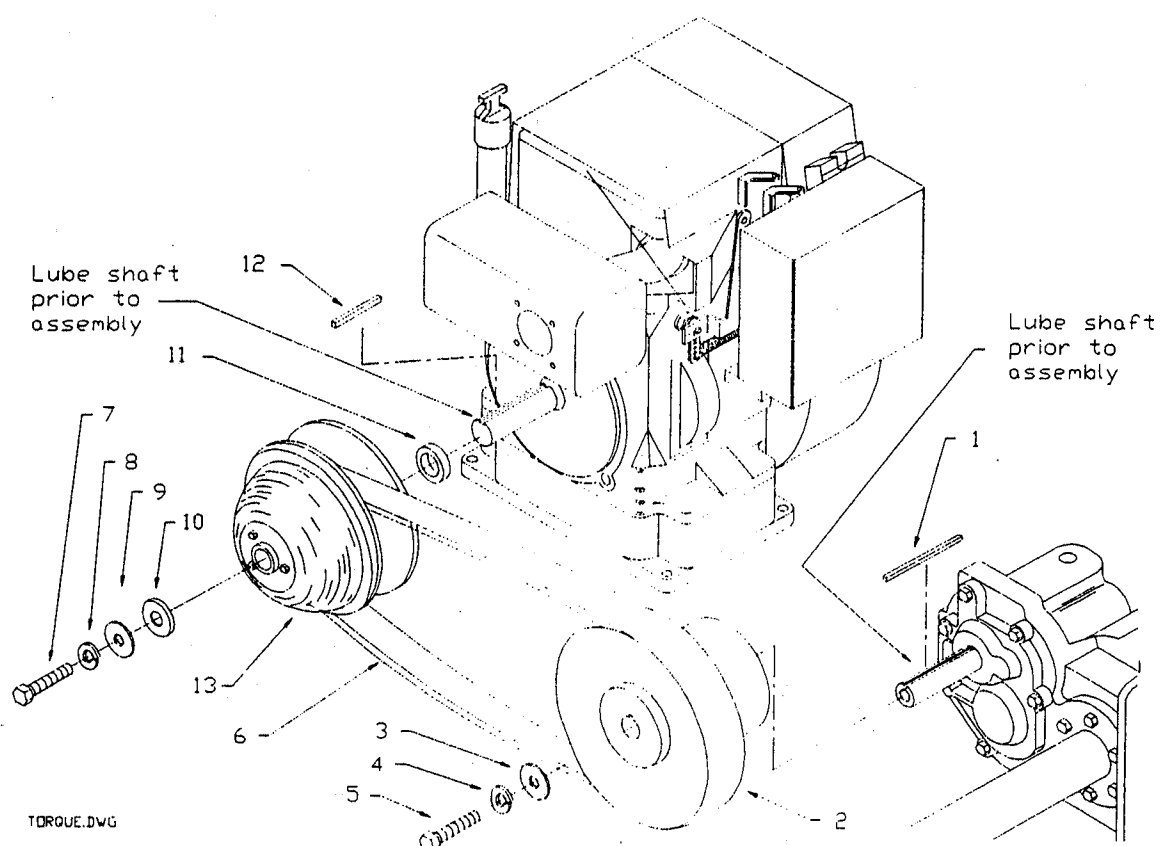

## THROTTLE AND CHOKE CABLE

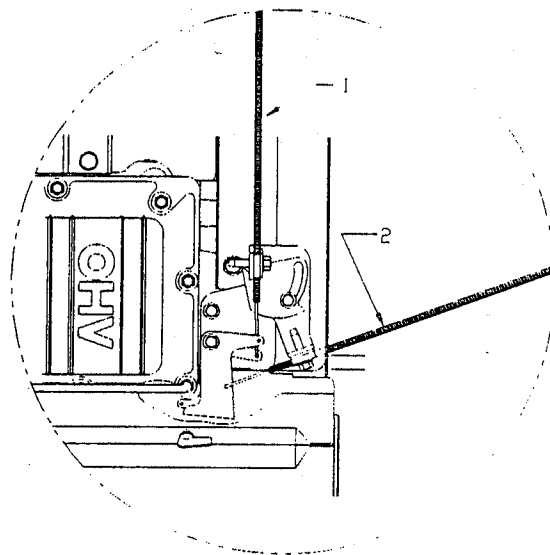

TORQUE CONVERTER			
ITEM #	PART #	DESCRIPTION	QTY
1.00	97-030-10	Key, 3/16 x 3	1
2	30-180-50	Secondary sheave	1
3	98-601-51	Flat washer	1
4	88-148-62	1/2" Split lock washer	1
5	89-112-30	12 x 1.75 x 50 Metric hex bolt	1
6	30-681-00	Drive belt	1
7	88-130-20	7/16 x 3 NF Hex bolt	1
8	88-128-62	7/16" Split lock washer	1
9	88-159-61	1/2" Flat washer (thick)	1
10	97-182-00	7/16" Cup washer	1
11	16-409-10	Spacer	1
12	97-030-20	Key, 3/16 x 1/4 x 2.5	1
13	30-181-00	Primary sheave	1
Not shown	30-180-51	Ramp shoe for secondary sheave (left)	3
15	30-180-52	Ramp shoe for secondary sheave (right)	3
THROTTLE AND CHOKE CABLES			
1	96-872-01	Throttle cable	1
2	96-860-01	Choke cable	1



# REAR SUSPENSION

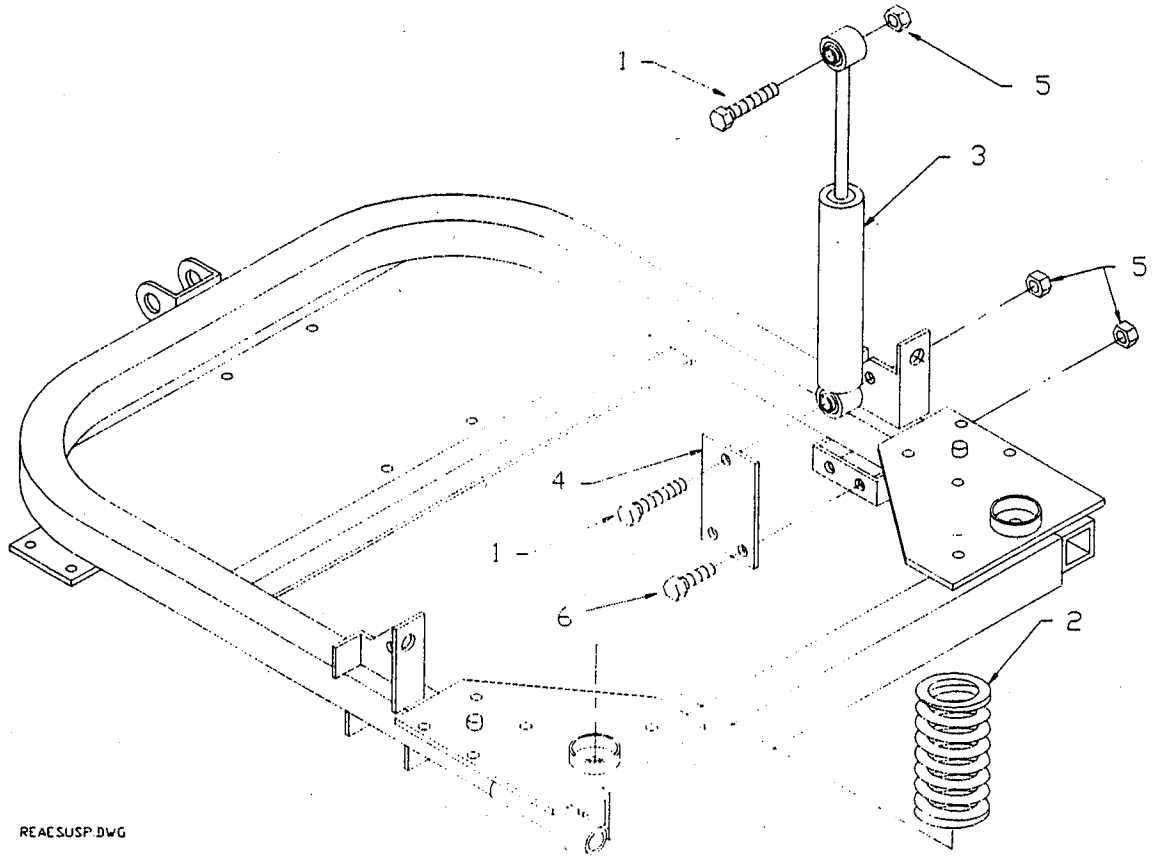

REASUSP.DWG

REAR SUSPENSION			
ITEM #	PART #	DESCRIPTION	QTY
1	88-120-17	7/16 x 2-1/4 Hex bolt	4
2	85-142-00	Spring	2
3	86-602-00	Shock	2
4	41-403-00	Shock bracket	2
5	88-129-81	7/16" Lock nut	8
6	88-120-11	7/16 x 1 Hex bolt	4
Not shown	10-081-00	Tire, 570 x 8, LR B	2
	10-086-00	Tire, 500 x 8 soft-solid (optional)	2
	92-000-00	Wheel cover, drop center (optional)	2
	92-002-00	Wheel cover, split rim (optional)	2

# FUEL TANK AND LINES

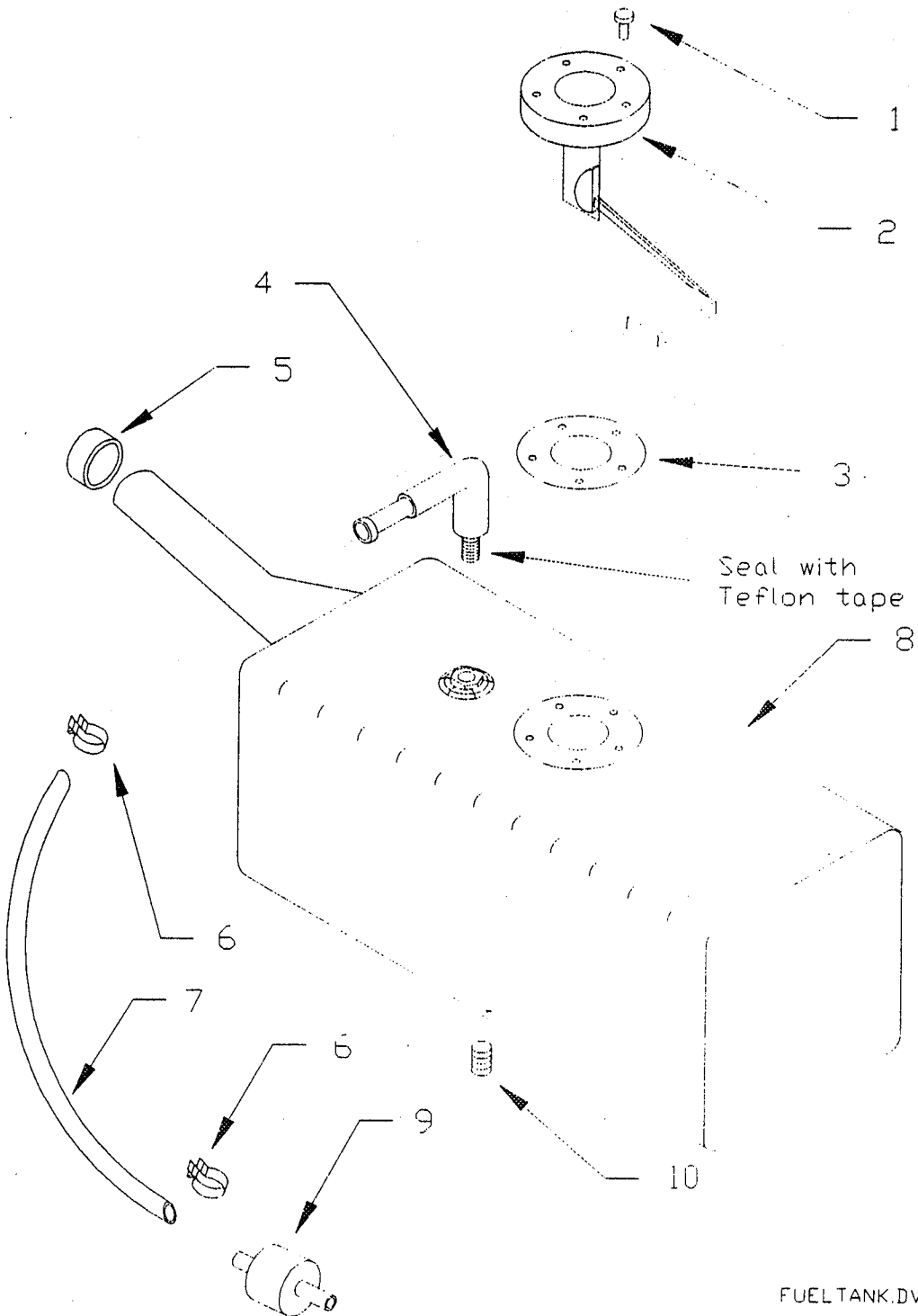

FUELTANK.DWG

FUEL TANK AND LINES			
ITEM #	PART #	DESCRIPTION	QTY
1	74-009-23	Screw (set of 5)	1
2	74-009-21	Fuel gauge sender	1
3	74-009-22	Gasket	1
4	96-154-10	Fuel tank fitting	1
5	05-210-01	Cap	1
6	96-608-10	Clamp	2
7	98-512-00	Fuel line	3.3'
8	02-210-78	Fuel tank	1
9	05-210-02	Fuel filter	1
10	96-154-00	Drain plug	1
NOT SHOWN	05-210-39	Mounting strap	2
	77-022-51	Rubber gasket on frame (around filler tube opening)	1

SECTION 4  
ILLUSTRATED PARTS LIST



# INSTRUMENT PANEL

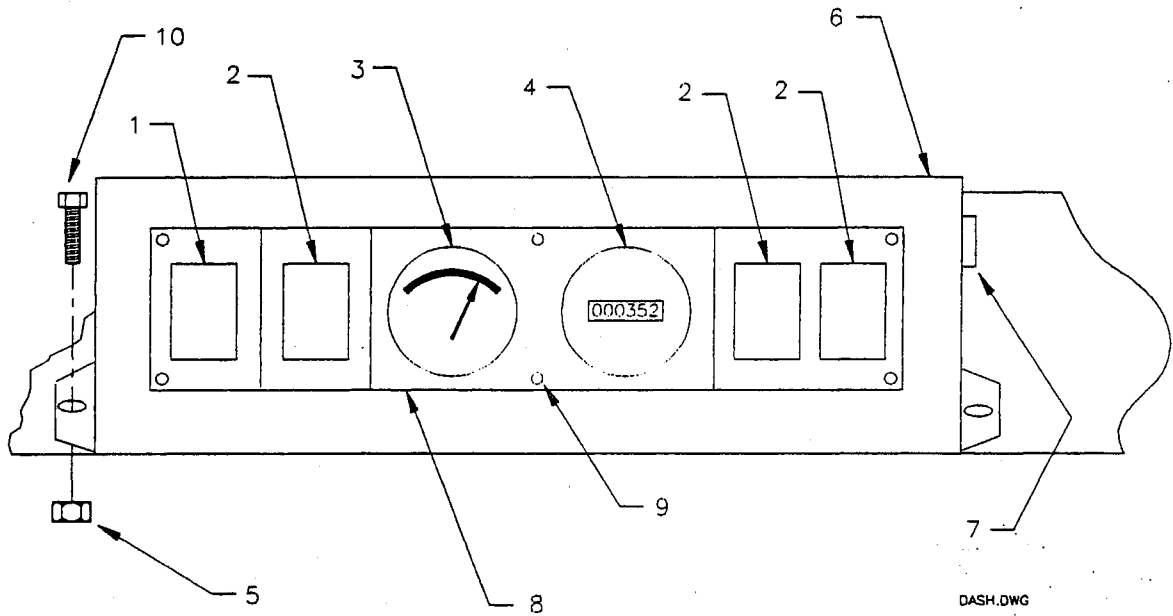

DASH PANEL			
ITEM #	PART #	DESCRIPTION	QTY
1	71-039-10	Switch	1
2	71-039-20	Hole plug (positions may contain optional switches)	3
3	74-009-20	Fuel gauge	1
4	74-000-00	Hour meter	1
5	88-069-81	1/4 Nut	2
6	00-610-01	Console	1
7	71-120-01	Key switch	1
8	94-304-18	Instrument panel	1
9	88-817-07	Sheet metal screw	6
10	88-065-08	1/4 x 5/8 Phillips head bolt	2

SECTION 4  
ILLUSTRATED PARTS LIST



# ELECTRICAL SYSTEM

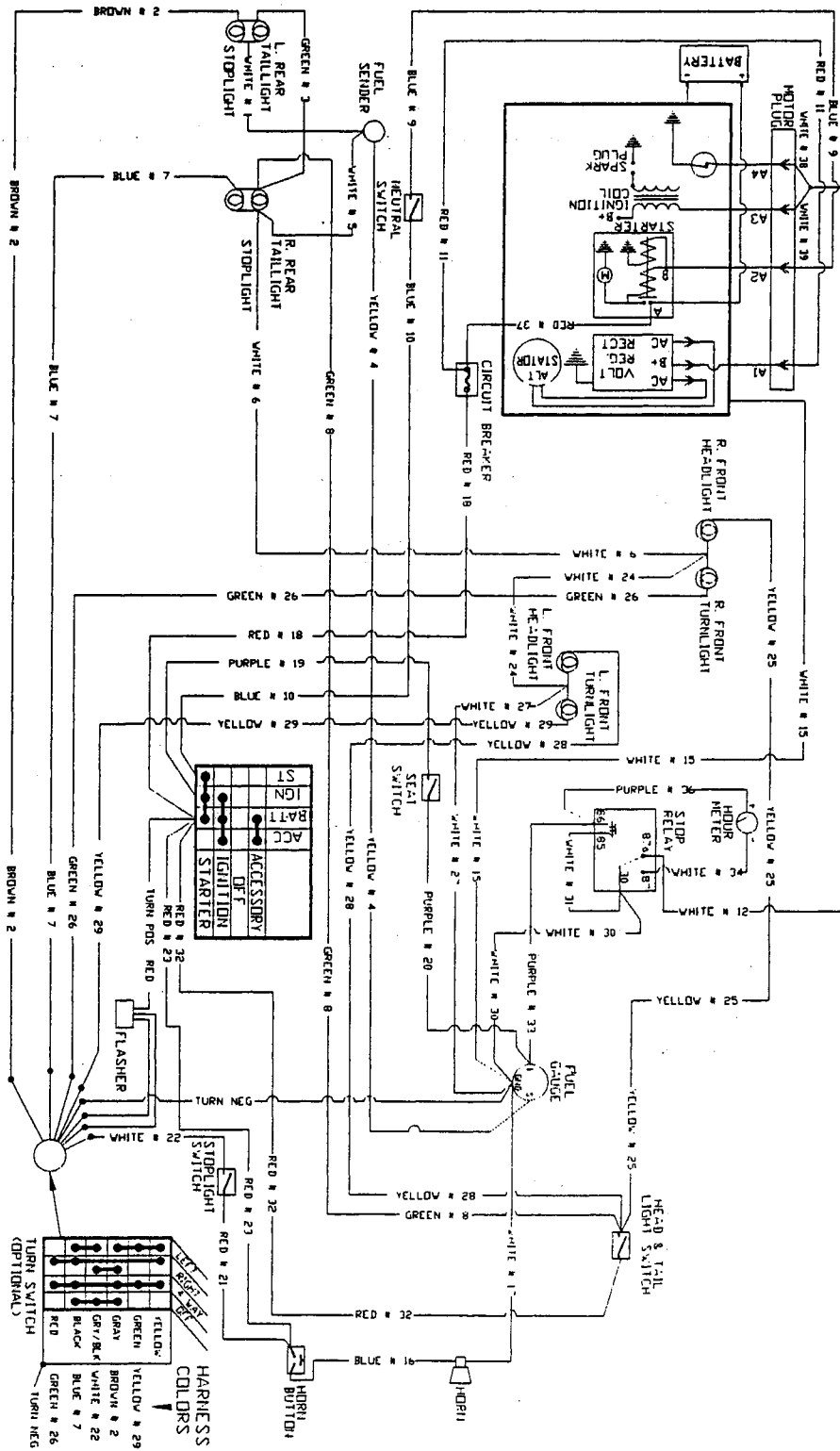

ELECTRICAL SYSTEM (FRAME)		
PART #	DESCRIPTION	QTY
71-120-01	Key switch	1
71-130-01	Neutral start switch	1
71-110-00	Brake light switch	1
71-141-20	Turn signal switch (optional)	1
71-039-10	Light switch	1
73-004-20	Horn	1
71-102-10	Seat switch	1
71-122-20	Horn button	1
71-303-01	Engine kill relay (behind dash panel)	1
71-900-05	Signal flasher	1
72-082-01	Headlight bulb	2
94-050-10	Left headlight assembly.	1
94-050-11	Right headlight assembly.	1
72-082-10	Front turn signal bulb (optional)	2
72-082-20	Turn signal bulb socket (optional)	2
72-025-00	Tail/stop light (w/rubber gasket and pigtail)	2
75-146-00	Harness	1
79-840-20	Circuit breaker	1
74-009-21	Fuel level sender	1
77-054-10	Battery	1



# FRAME

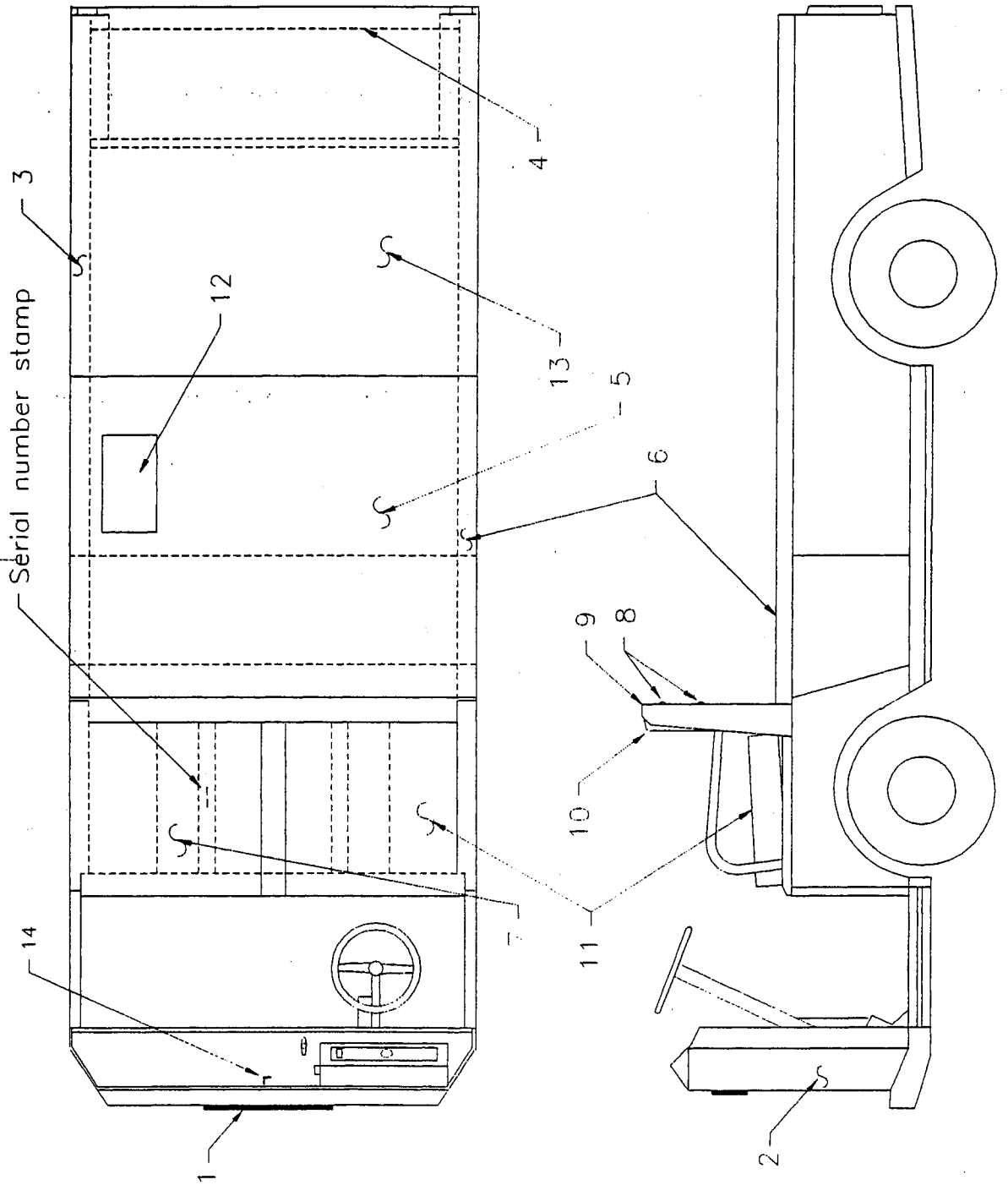

FRAME			
ITEM #	PART #	DESCRIPTION	QTY
1	94-201-10	TAYLOR-DUNN name plate	1
NOT SHOWN	88-817-07	Name plate screw	6
	94-201-11	Name plate fastener (plastic)	2
2	00-610-08	Front cowl weldment (not painted)	1
3	00-210-14	Side deck angle	1
4	00-210-18	Rear deck angle	1
5	90-444-30	Deckboard front	1
NOT SHOWN	90-440-62	Deckboard front cover	1
	90-440-61	Deckboard rear cover	1
	05-210-91	Deckboard heat shield	1
	88-607-09	Deckboard rivets	16
6	00-210-14	Side deck angle	1
7	90-174-00	Passenger seat cushion	1
8	88-837-09	Seat back screws	6
9	00-210-04	Seat back weldment	1
10	90-179-00	Seat back cushion	1
11	90-174-00	Driver seat cushion	1
12	77-054-10	Battery (standard)	1
NOT SHOWN	50-243-10	Battery hold down rod	2
13	90-444-20	Deckboard rear	1
14	02-210-25	Wire harness cover	1
NOT SHOWN	90-199-10	Seat belt (1 set)	2

## DECALS/WARNING LABELS

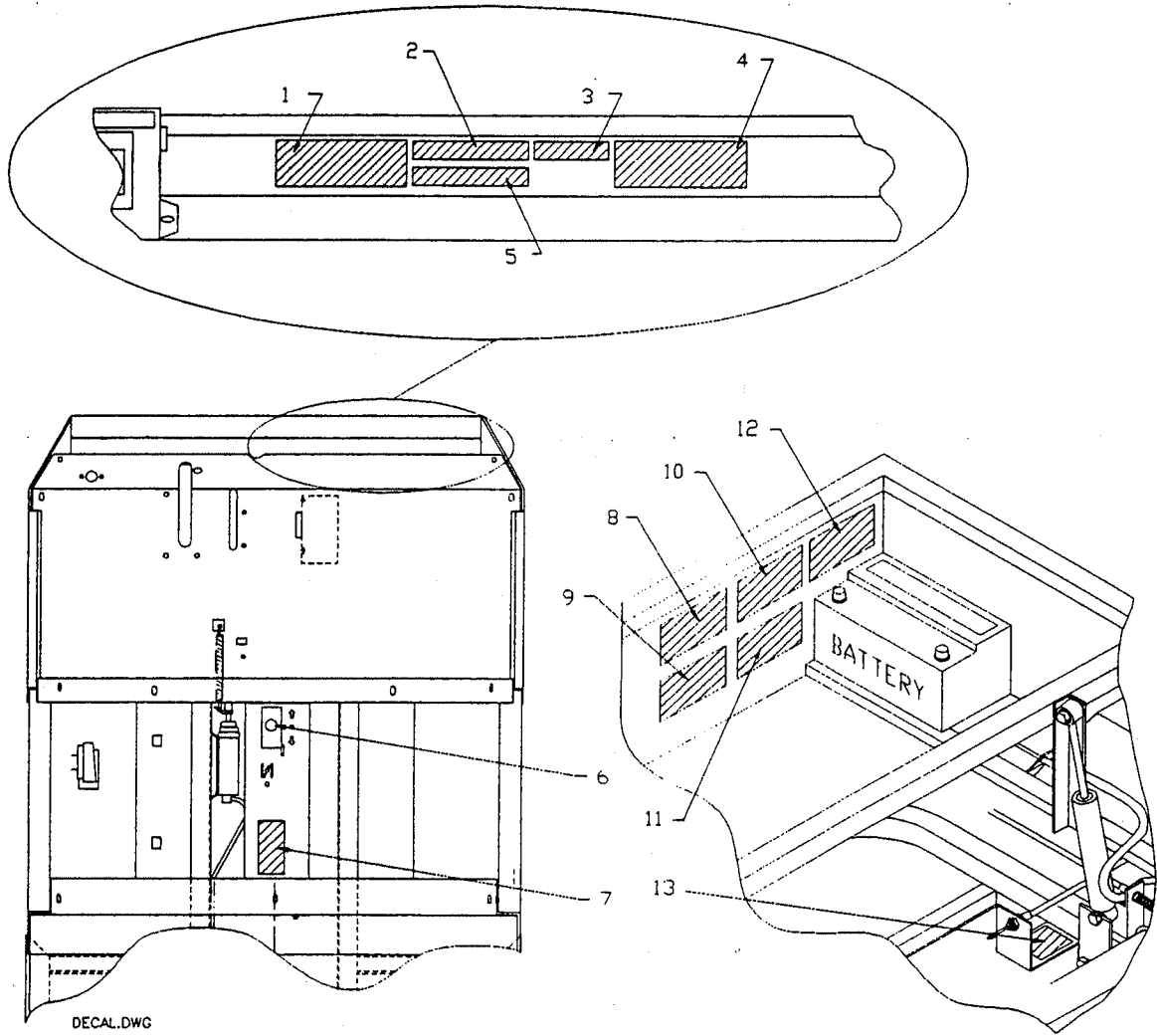

DECALS/WARNING LABELS			
ITEM #	PART #	DESCRIPTION	QTY
1	94-306-00	Operator warning	1
2	94-384-01	"Not a motor vehicle"	1
3	94-306-01	Fuel /oil check	1
4	94-306-02	Speed warning	1
5	94-373-05	Data plate	1
6	94-306-07	"Push to shift"	1
7	94-306-09	Do not shift while moving	1
8	94-306-03	Heat warning	1
9	94-306-04	Rotating parts warning	1
10	94-306-05	Oil type	1
11	94-306-06	Dipstick warning	1
12	94-313-00	Battery warning	1
13	94-306-08	Do not drill (spring steel)	1

SECTION 4  
ILLUSTRATED PARTS LIST



# DANA DRIVE

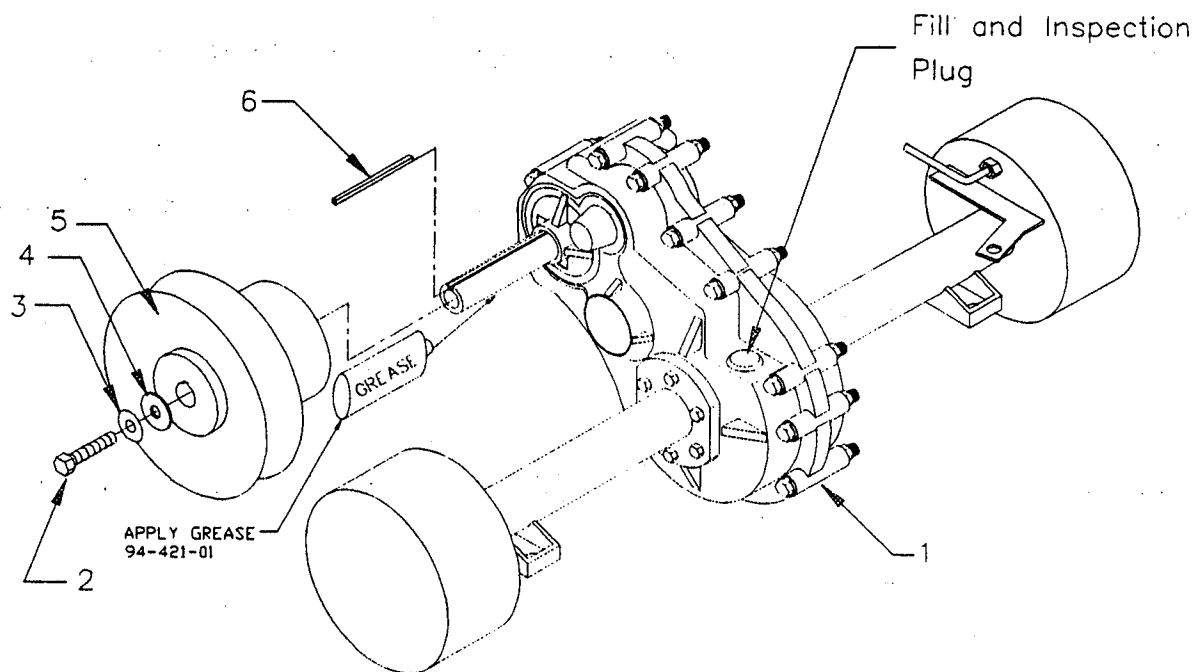

DANA DRIVE			
ITEM #	PART #	DESCRIPTION	QTY
1	4C-610-20	Drive, fwd/neu/rev, w/hydraulic brakes	1
2	89-112-30	M12 X 1.25 X 50MM Hex screw	1
3	88-148-62	1/2 in. Lock washer	1
4	98-601-57	Washer, 1/2 ID mount	1
5	30-182-00	Pulley assembly, driven, long life	1
6	97-030-10	Key, 3/16 X 3/16 X 3	1

SECTION 4  
ILLUSTRATED PARTS LIST



# ENGINE MOUNT (Serial #'s After 127633)

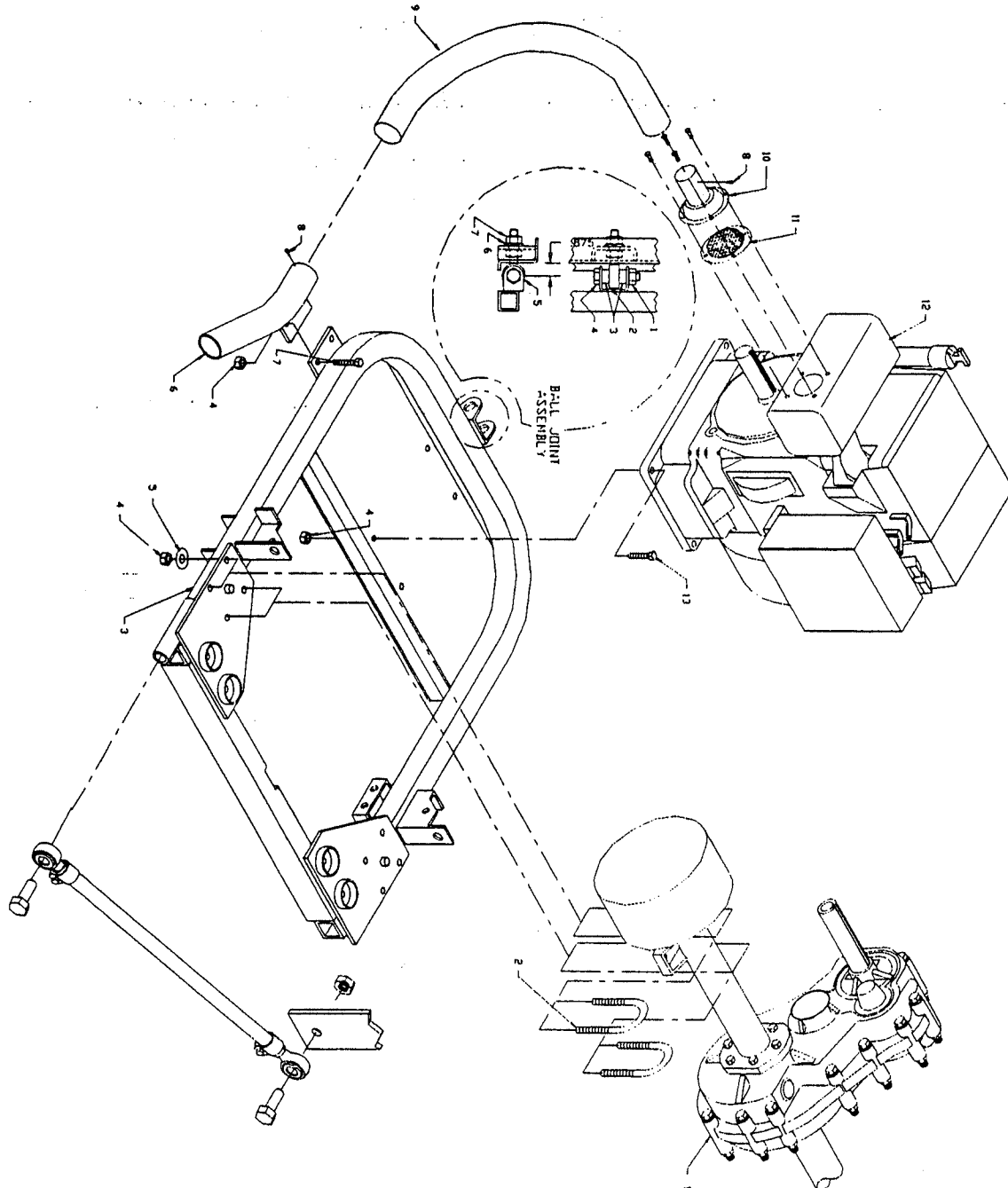

ENGINE MOUNT			
ITEM #	PART #	DESCRIPTION	QTY
1	4C-610-20	Drive, Fwd/Neu/Rev, W/Hyd Brakes	1
2	96-123-50	U-Bolt	4
3	00-610-22	Swing Arm	1
4	88-109-81	3/8 NC Lock Nut	14
5	88-108-62	3/8 Lock Washer	8
6	00-610-17	Tail Pipe	1
7	88-100-11	3/8 X 1 Hex Screw	2
8	88-828-09	#10 X 3/4 Sheet Metal Screw	2
9	66-400-45	Exhaust Extension	1
10	00-610-32	Exhaust Extension Adapter	1
11	66-400-20	Spark Arrester	1
12	67-001-00	Engine Assembly	1
13	88-101-13	3/8 X 1 1/4 Hex Screw (Grade 5)	4
BALL JOINT ASSEMBLY			
1	88-229-81	3/4 NC Lock Nut	1
2	86-523-99	Front Engine Mount	1
3	16-406-00	Spacer, 7/16	2
4	88-220-22	3/4 X 3 1/2 Hex Bolt	1
5	88-229-62	3/4 Split-Lock Washer	1
6	88-239-80	3/4 NF Hex Nut	1



# SHIFTING LINKAGE (For Serial #'s After 127633)

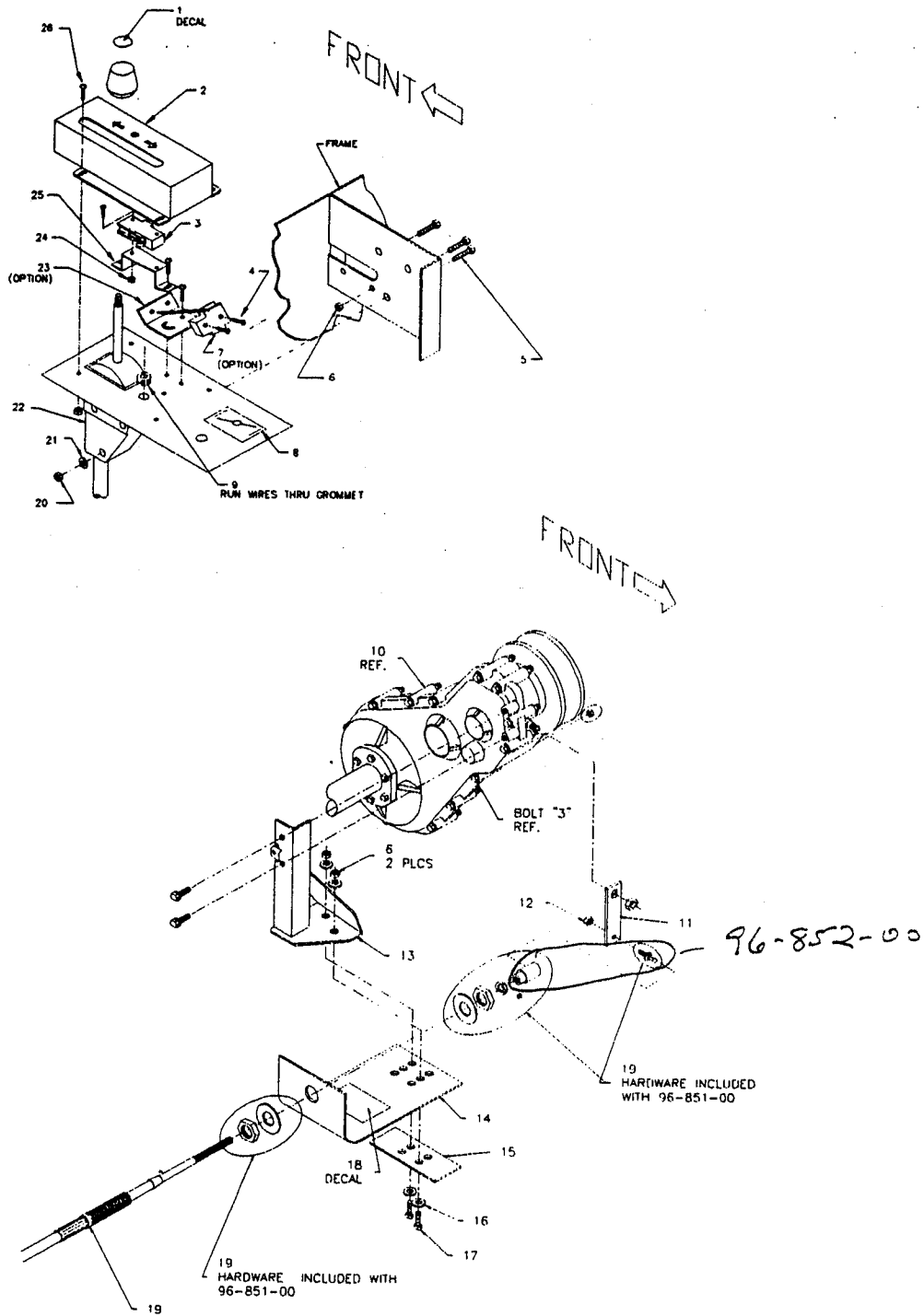

SHIFTING LINKAGE			
ITEM #	PART #	DESCRIPTION	QTY
1	94-306-07	"Push To Shift" Decal	1
2	00-610-34	Neutral Switch Bracket	1
3	71-130-01	Neutral Start Switch	1
4	88-014-13	6-32 X 1-1/4 Machine Screw	2
5	88-080-18	5/16 X 2-1/2 Hex Bolt	3
6	88-109-81	3/8 NC Lock Nut	4
7	71-135-01	Micro Switch BZ-2RW80-A2	1
8	94-306-12	Decal, Choke	1
9	98-603-00	Grommet, Rubber 3/8 IN. ID	1
10	4C-610-20	Dana Drive (For Reference Only)	1
11	00-610-20	Wldmnt, Park Brake, Link	1
12	88-079-85	1/4 NF Lock Nut	1
13	00-610-84	Wldmnt, Shift Cable Mnt Bracket	1
14	00-610-25	Mounting Bracket	1
15	00-610-83	Plate, Shft Cable Mnt Bracket	1
16	88-108-61	3/8 SAE Washer	4
17	88-100-11	3/8 X 1 NC Hex Hd Screw	2
18	94-306-08	Decal, Spring Steel	1
19	96-851-00	Shift Cable	1
20	89-089-81	5/16 NC Lock Nut	1
21	88-088-61	5/16 SAE Washer	3
22	96-853-10	Shift Quadrant	1
23	00-610-36	(Option)	1
24	88-019-86	6-32 Lock Nut	2
25	00-610-35	Bracket, Neutral Switch, G-150	1
26	88-025-06	8-32 X1/2 Trus Hd Mach Scr	8



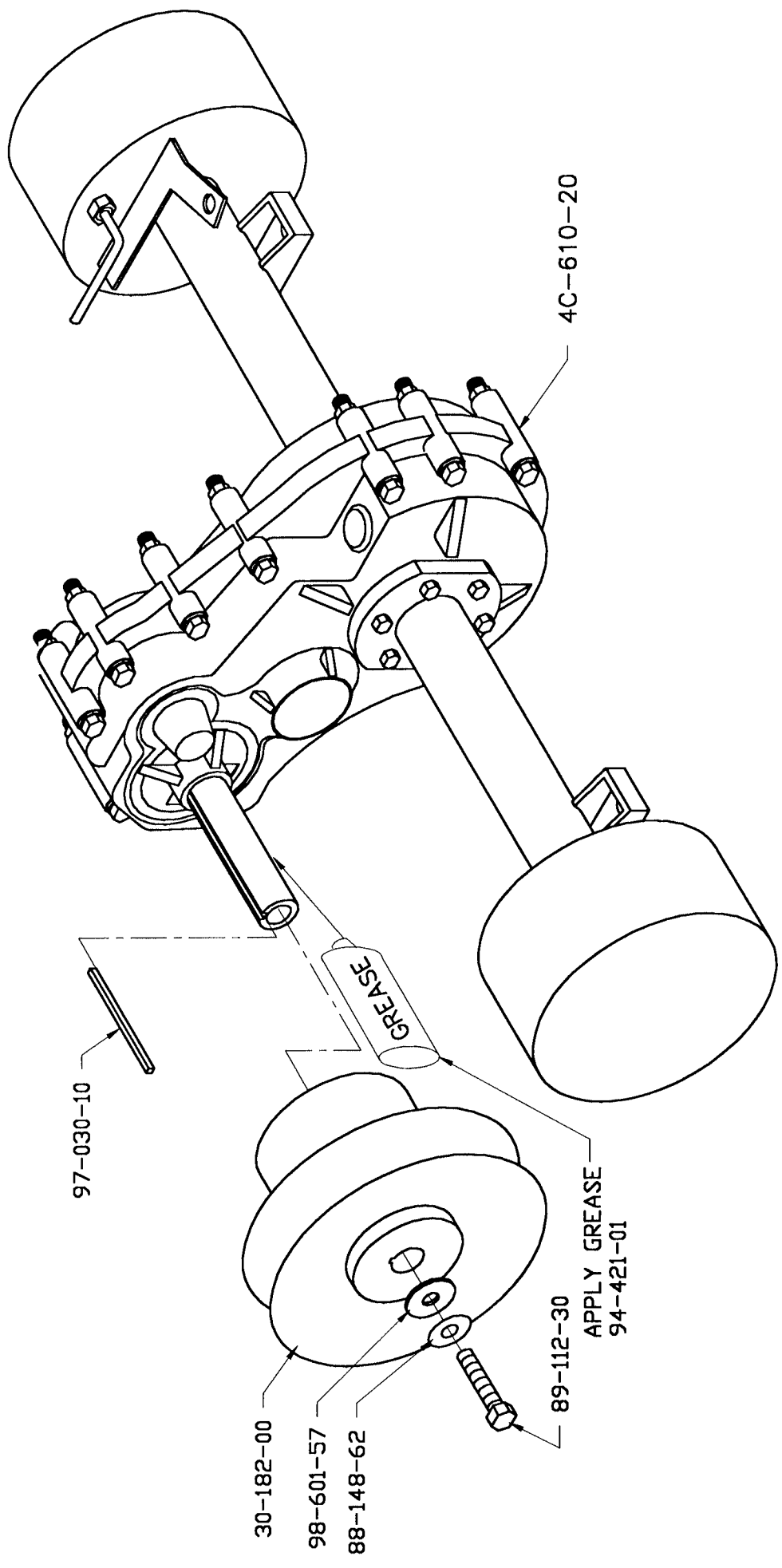

4C-610-20

97-030-10

GREASE

APPLY GREASE  
94-421-01

89-112-30

30-182-00

98-601-57

88-148-62

# Engineering ECN Release (Final)

Packages released on: Tuesday, June 08, 1999

Move	Seq. #	Laser	Part Number	ENG	Description	Revision	Disposition
<input type="checkbox"/>			W2-680-20	EH	Weldment, Main Frame, R 6-80	Modified frame, added tab.	
<input type="checkbox"/>			R2-680-30	EH	Std Parts, R 6-80	Modified brake system. Added components.	
<input type="checkbox"/>			MLX-230562	KH	GASKET,CARB.MTG(FOR 00-680-	Created item	
<input type="checkbox"/>			MLX-230169	KH	O-RING(FOR 00-680-90)	Created item	
<input type="checkbox"/>			MLX-230145	KH	RETAINER RING(FOR 00-680-90)	Created item	
<input type="checkbox"/>			97-318-73	KH	LOCK CYLINDER(FOR 97-318-00)	Created item and package for OTC requirement	
<input type="checkbox"/>			50-660-07	KS	ARM,BRAKE	Revised part for laser production	
<input type="checkbox"/>			50-002-17	EH	ROD,LINKAGE,5/16 X 9, THREAD	Created item and package	
<input type="checkbox"/>			19-004-30	TD	CAP, HORN BUTTON, 19-005-17	Created item and package	
<input type="checkbox"/>			01-680-54	EH	Park Brake Actuator	Revised part profile measurement changes	
<input type="checkbox"/>			01-680-44	TD	Brake Equalizer	Revised part profile	MRB
<input type="checkbox"/>			01-680-01	EH	BRAKE TAB,	Revised part profile	
<input type="checkbox"/>			00-680-07	EH	Weldment, Brake Lever	Revised angle of tab, 45 degree was 30 degree	

Total Released: 13

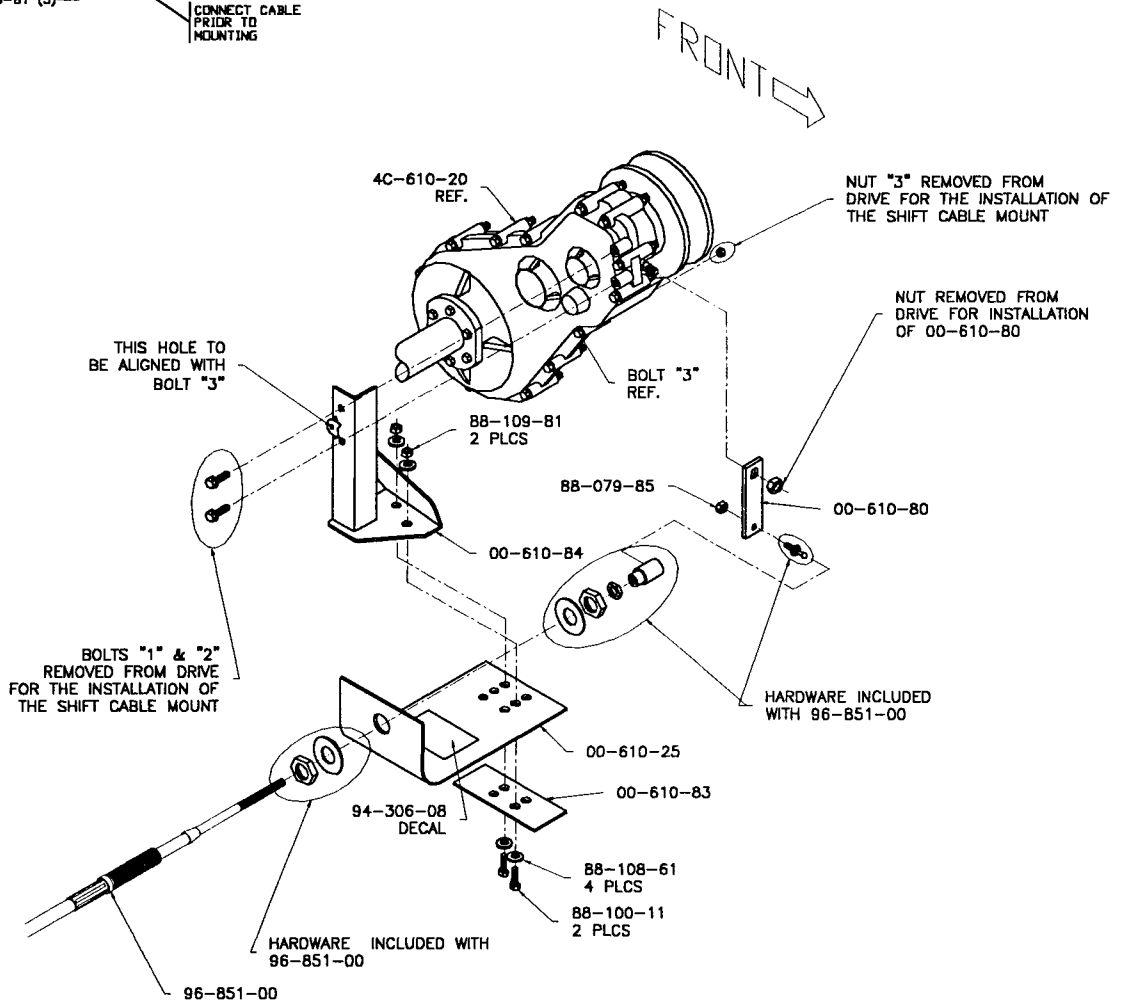
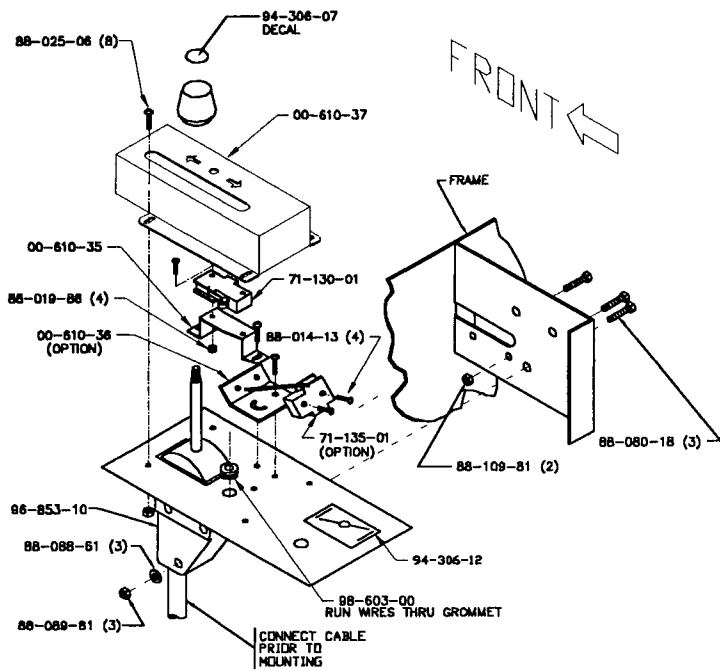

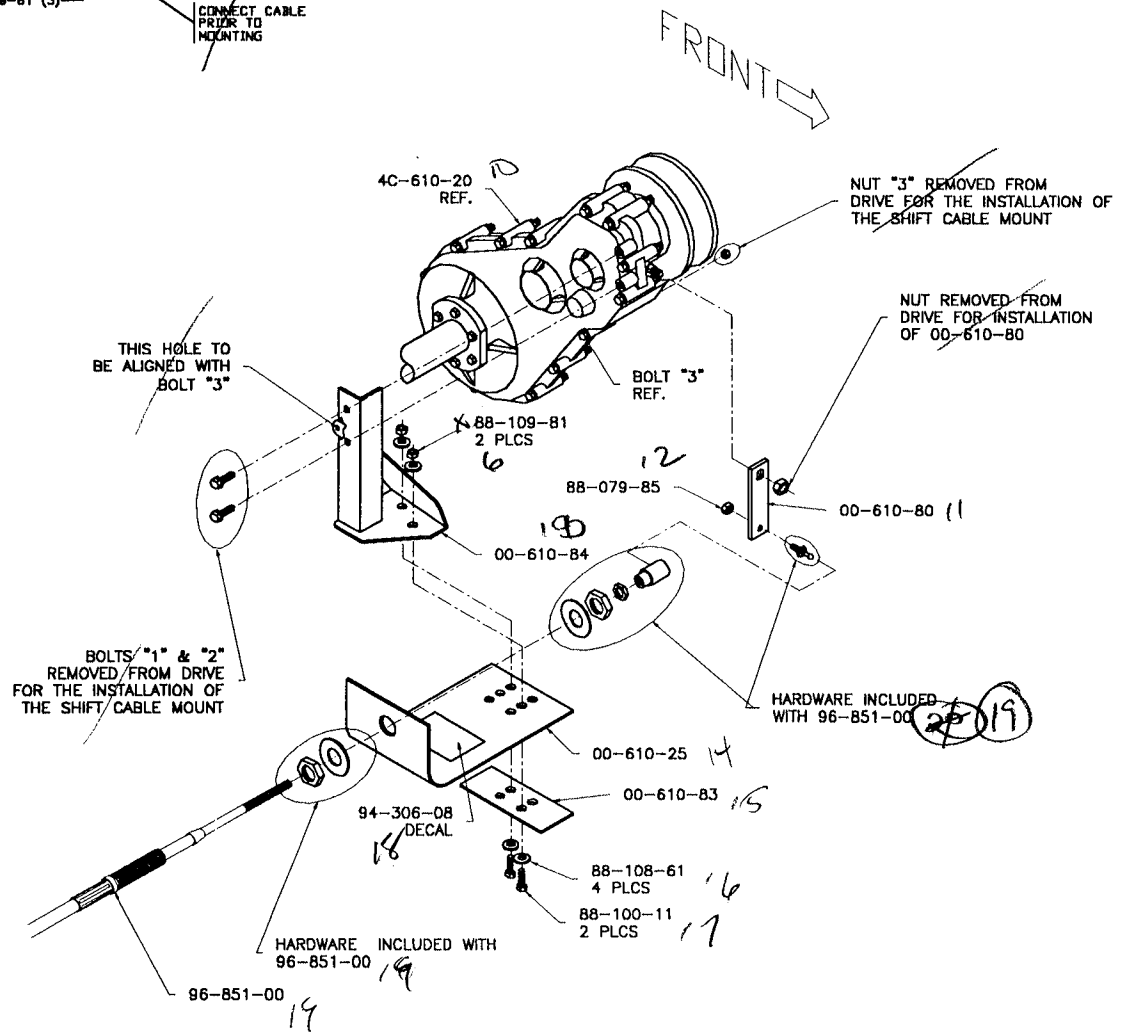
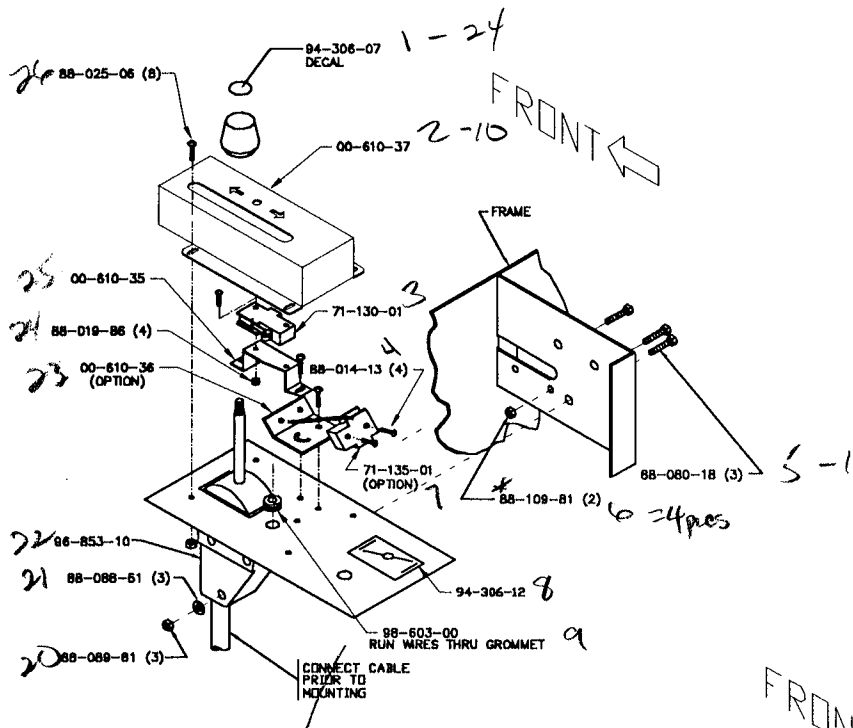

# SHIFTING LINKAGE

*SEE HENRY*

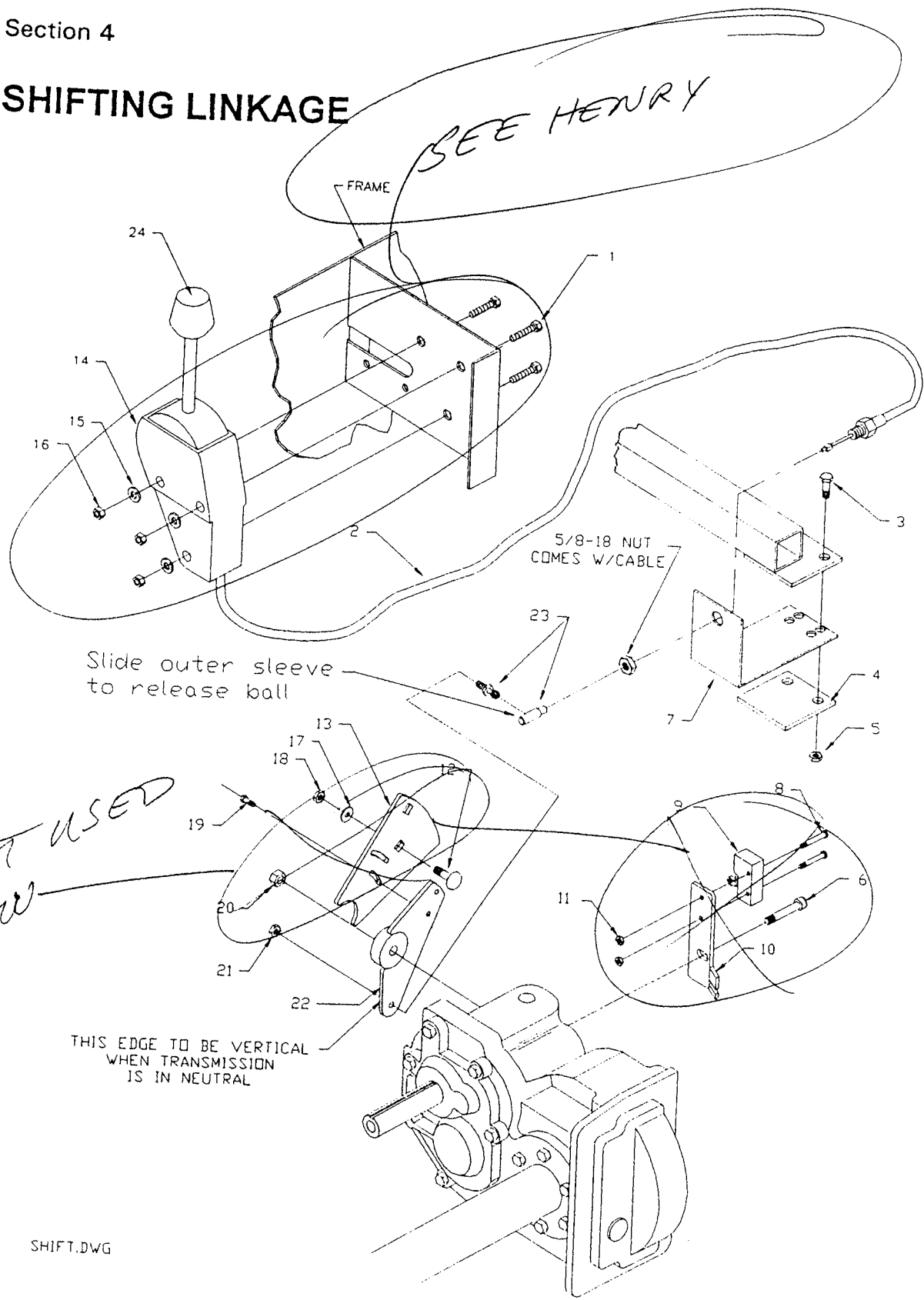

Slide outer sleeve to release ball

5/8-18 NUT COMES W/CABLE

*NOT USED  
NEW*

THIS EDGE TO BE VERTICAL WHEN TRANSMISSION IS IN NEUTRAL

SHIFT.DWG

*NEW SET UP (EVEN ON THE OLD DATA DRIVE) IS AT THE SHIFT LEVER*



# 1966 OLDSMOBILE DRIVE SHAFT ASSEMBLY

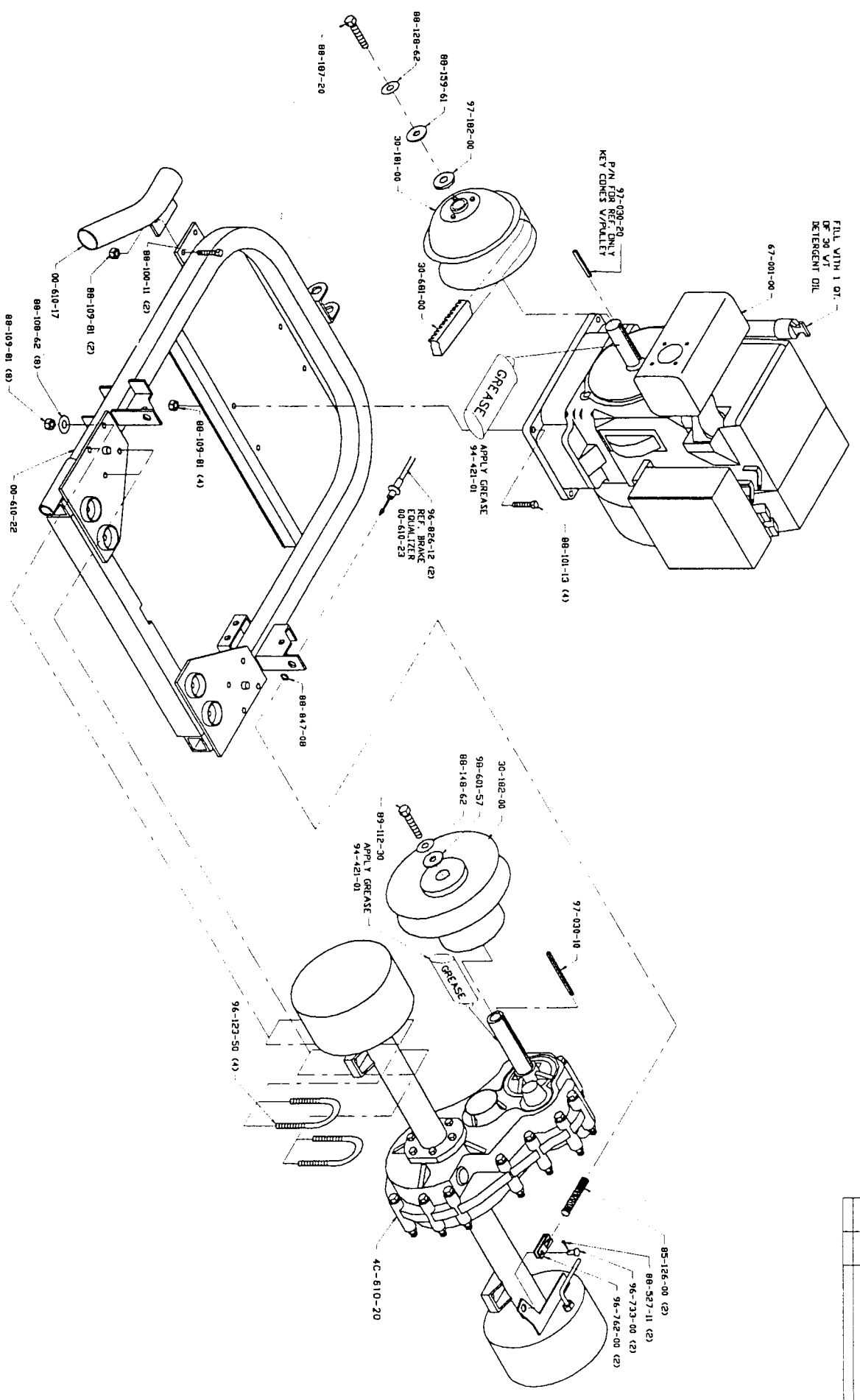

REV.	REV. NO.	DESCRIPTION	REV.
A	1	RELEASE FOR PRODUCTION	1

00-810-48  
 0-1-73  
 00-810-48  
 DRIVE SHAFT ASSEMBLY  
 0-1-73

# DRIVE ENGINEERING REVISION PRINT

DATE	REV. NO.	DESCRIPTION	REV. BY
01/07/81	A	RELEASE FOR PRODUCTION	JW

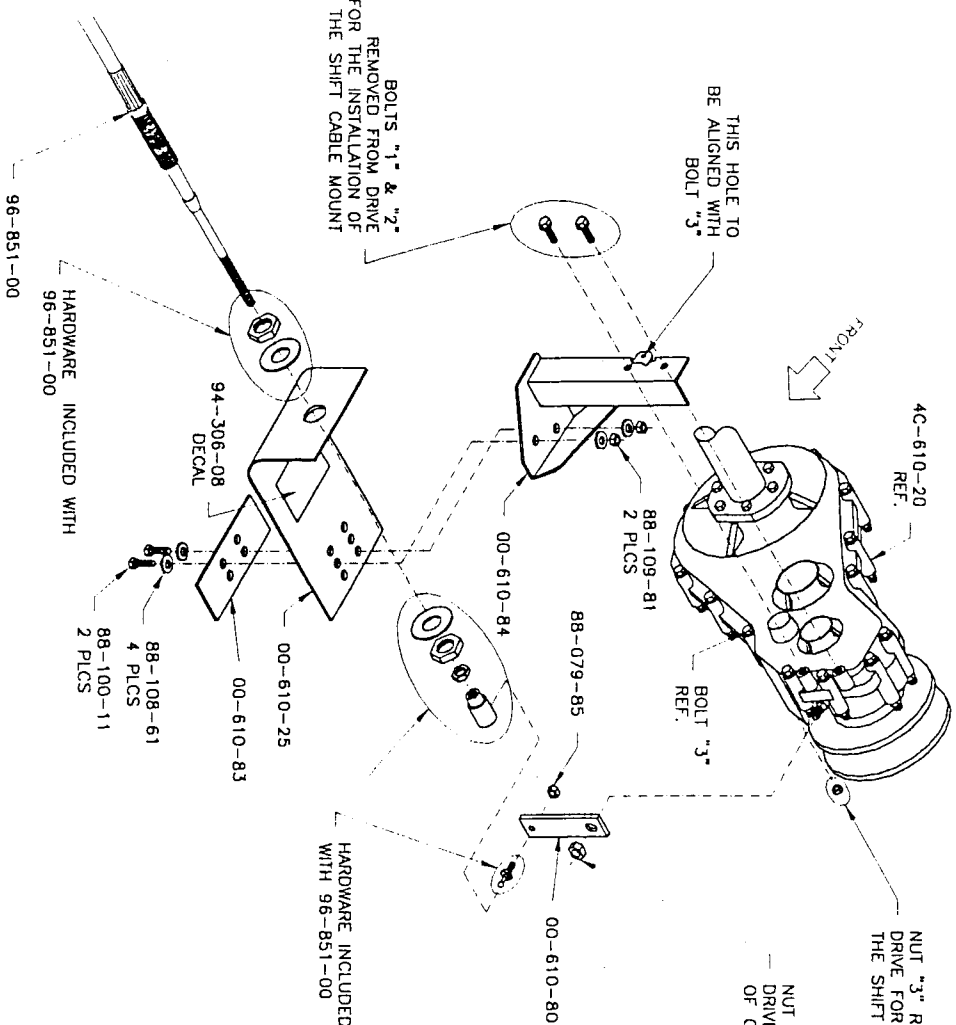

- 1 ASSEMBLE THE SHIFTING CABLE MOUNT BEFORE INSTALLING IT ON THE DRIVE. THIS INCLUDES: 00-610-84, 00-610-25, 00-610-83, AND 94-306-08.
- 2 BEGIN INSTALLATION OF THE SHIFTING CABLE MOUNT TO THE DRIVE BY INSTALLING NUT "3" FIRST. COMPLETE THE PROCEDURE BY INSTALLING BOLTS "1" AND "2."

## SHIFTING CABLE MOUNT ASSEMBLY

- 1 INSTALL THE TAIL END OF THE SHIFTING CABLE INTO THE L-SPRING PLATE (00-610-25)
- 2 INSTALL THE FRONT END OF THE SHIFTING CABLE INTO THE TOOLING SHIFTER.
- 3 MOVE THE SHIFTING LEVER TO THE NEUTRAL POSITION UNTIL IT SITS IN THE DETENT.
- 4 TURN THE SHIFT PLATE ON THE TRANSMISSION IN THE CLOCKWISE DIRECTION UNTIL THE FORWARD GEAR IS ENGAGED. YOU MAY NEED TO ROTATE THE PULLEY TO LOCK IT IN GEAR.
- 5 TURN THE SHIFT PLATE ON THE TRANSMISSION IN THE COUNTERCLOCKWISE DIRECTION UNTIL THE REVERSE GEAR IS ENGAGED. YOU MAY NEED TO ROTATE THE PULLEY TO LOCK IT IN GEAR.
- 6 REPEAT STEPS 4 AND 5 A FEW TIMES SO THAT YOU CAN ESTIMATE THE IMAGINARY NEUTRAL POSITION OF THE BALL STUD.
- 7 ADJUST THE LOCATION OF THE CABLE ON THE L-SPRING PLATE SO THAT THE CENTER OF THE BALL STUD RECEPTACLE IS ROUGHLY AT THE IMAGINARY NEUTRAL POSITION OF THE BALL STUD. SLIDE THE RECEPTACLE SLEEVE (SPRING LOADED) TOWARDS THE JAM NUT AND POP THE BALL STUD INTO THE RECEPTACLE.
- 8 TEST SHIFTING INTO FORWARD, NEUTRAL, AND REVERSE. YOU MAY NEED TO ROTATE THE WHEELS TO CONFIRM SHIFT LOCATIONS. REMOVE THE TOOLING SHIFTER.

## SHIFTING CABLE ADJUSTMENT



**SEE ENGINEERING  
FOR LARGER PRINT**

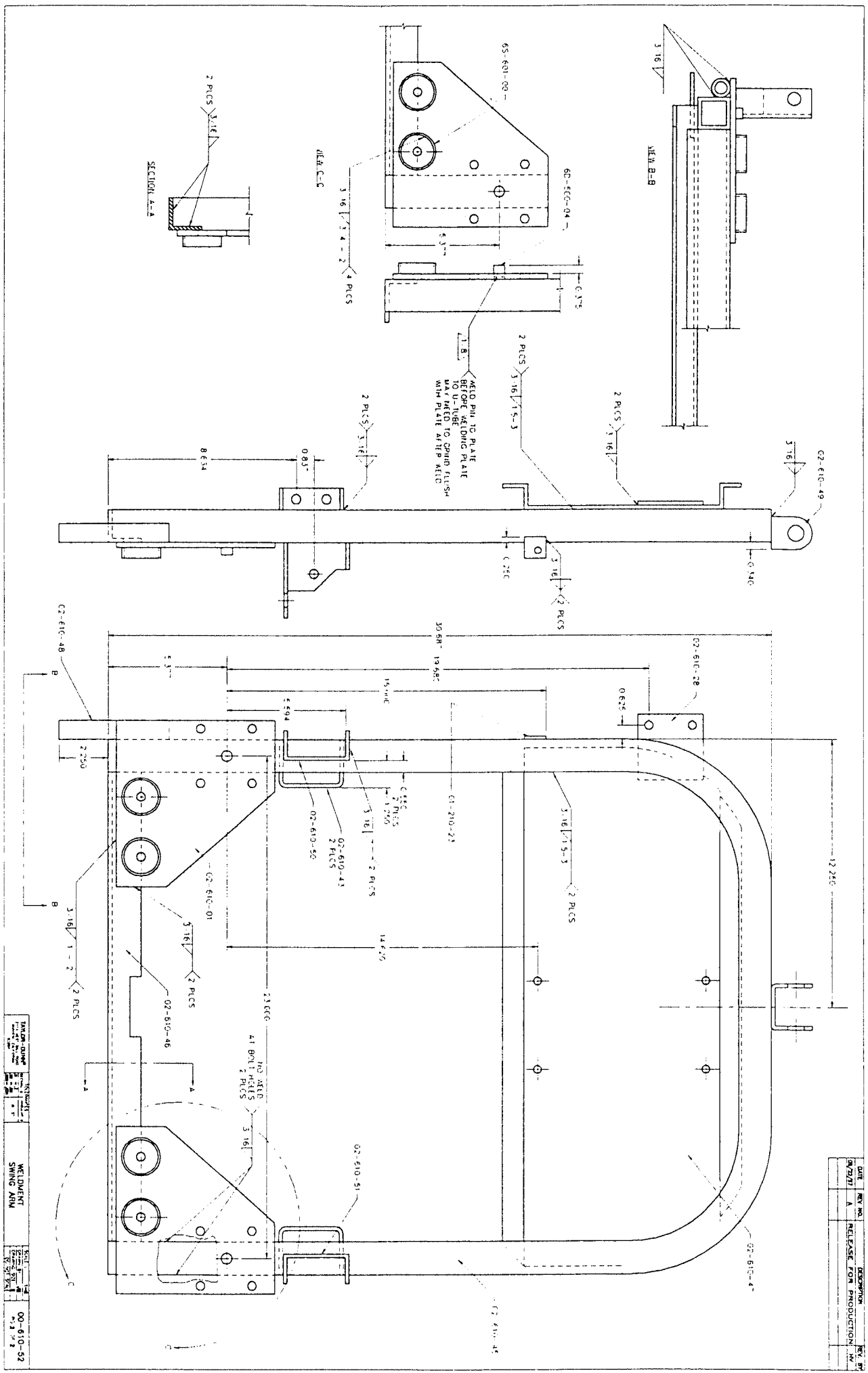

DATE	REV. NO.	DESCRIPTION	REV. BY
9/2/71	A	RELEASE FOR PRODUCTION	MM

00-610-52	WELDING SHOP	00-610-52
-----------	--------------	-----------

DATE	REV NO.	DESCRIPTION	REV. BY
09/17/97	A	RELEASE FOR PRODUCTION	HV

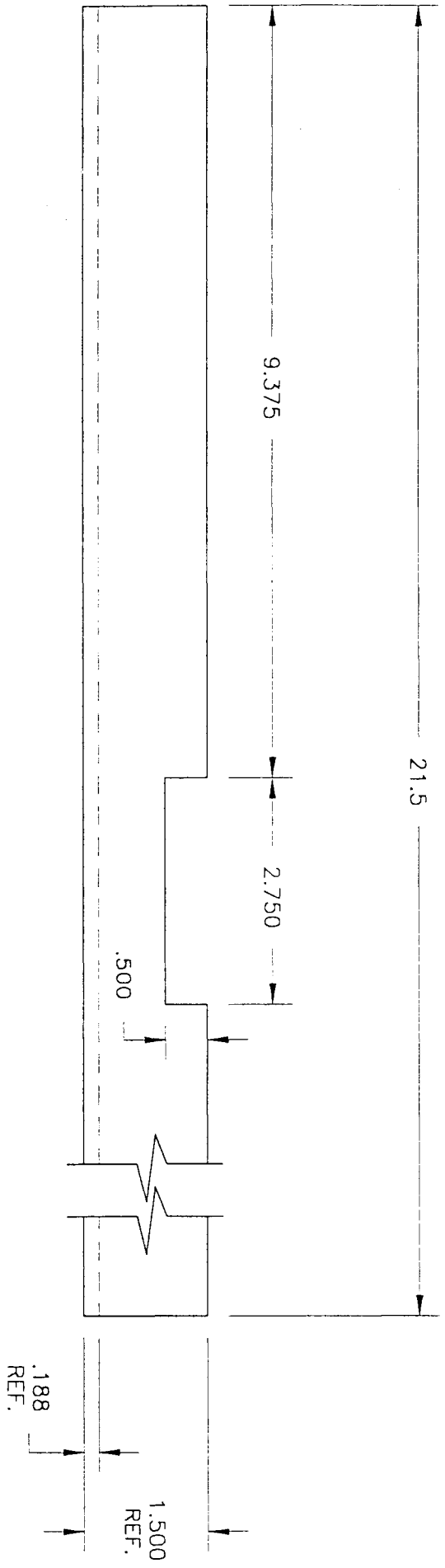

MAT'L: 1-1/2 X 1-1/2 X 3/16 ANGLE HR STEEL

TAYLOR-DUNN  
 2114 WEST BIRD AVE  
 ANN ARBOR, MI 48106  
 928C4

ANGLE, NOTCHED, SWING  
 ARM, BG 1-50

SCALE: 1-2  
 DRAWN BY: HV  
 DRAWING SIZE: A  
 CUSTOMER SCALE

02-610-46  
 PG 2 OF 2

TOLERANCES

DECIMALS	FRACTIONS
± .1	± 1/16
± .06	± 3/64
± .031	± 1/32

# 50120000000000000000

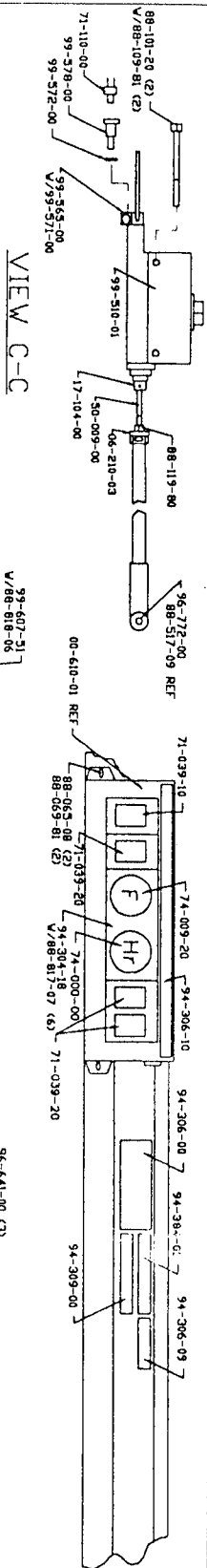

VIEW C-C

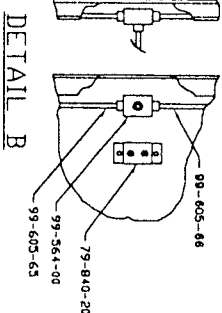
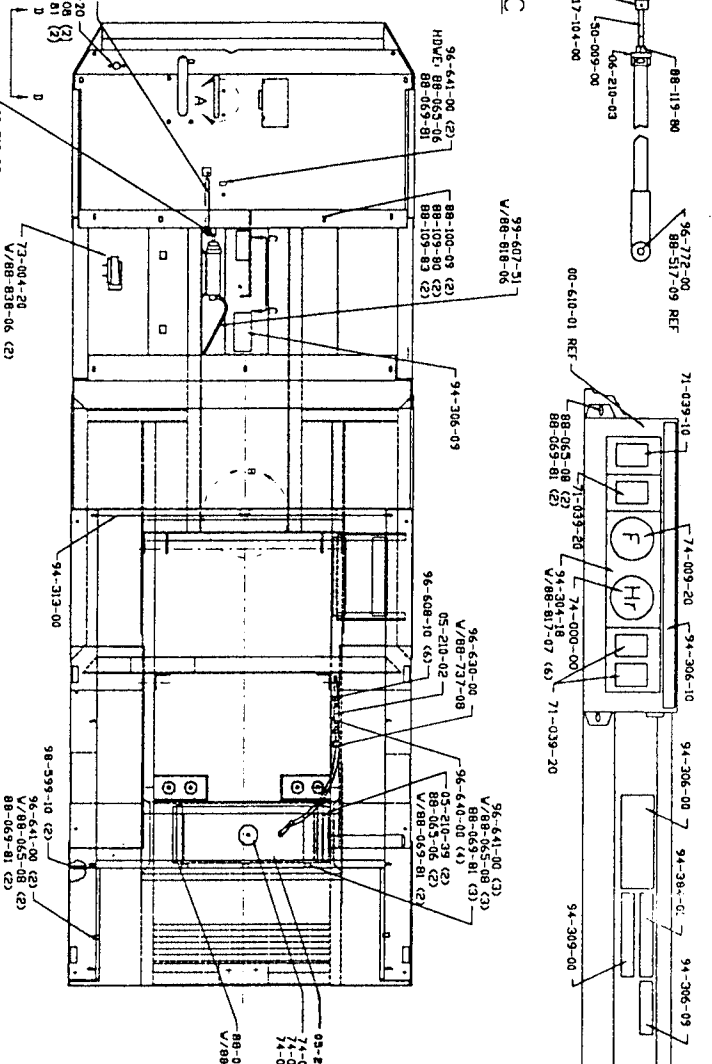
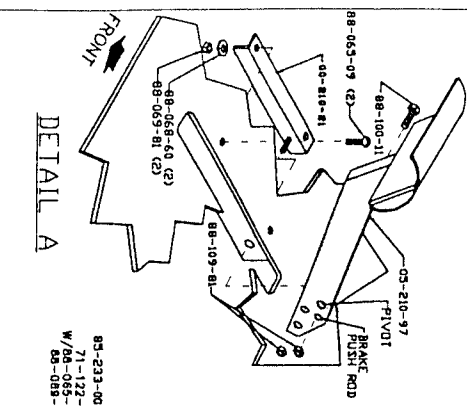

DETAIL B

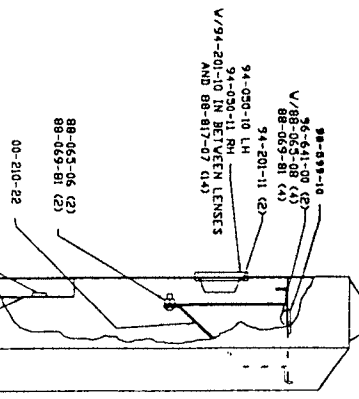

VIEW D-D

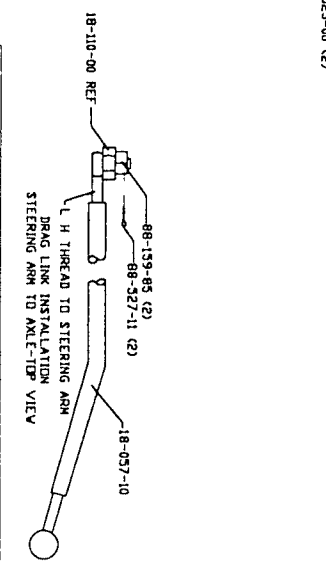
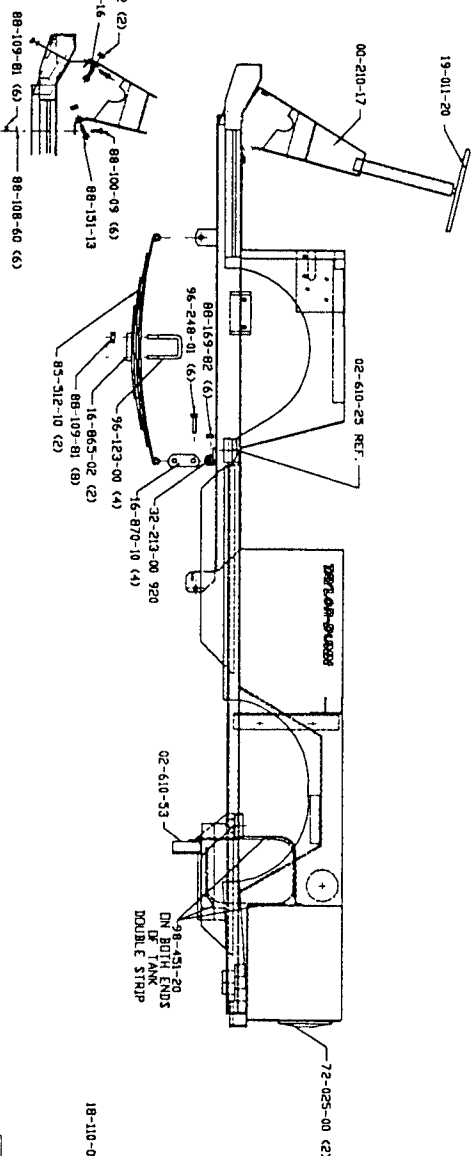
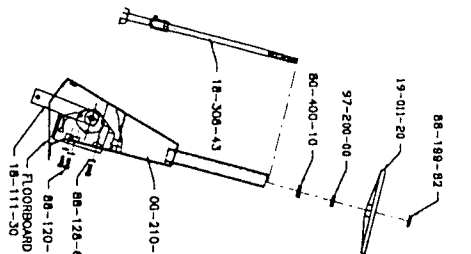

## STEERING ASSY DETAIL

DATE	REV	DESCRIPTION
82-610-40	A	RELEASE FOR PRODUCTION

# FRONT LARGER PARTS

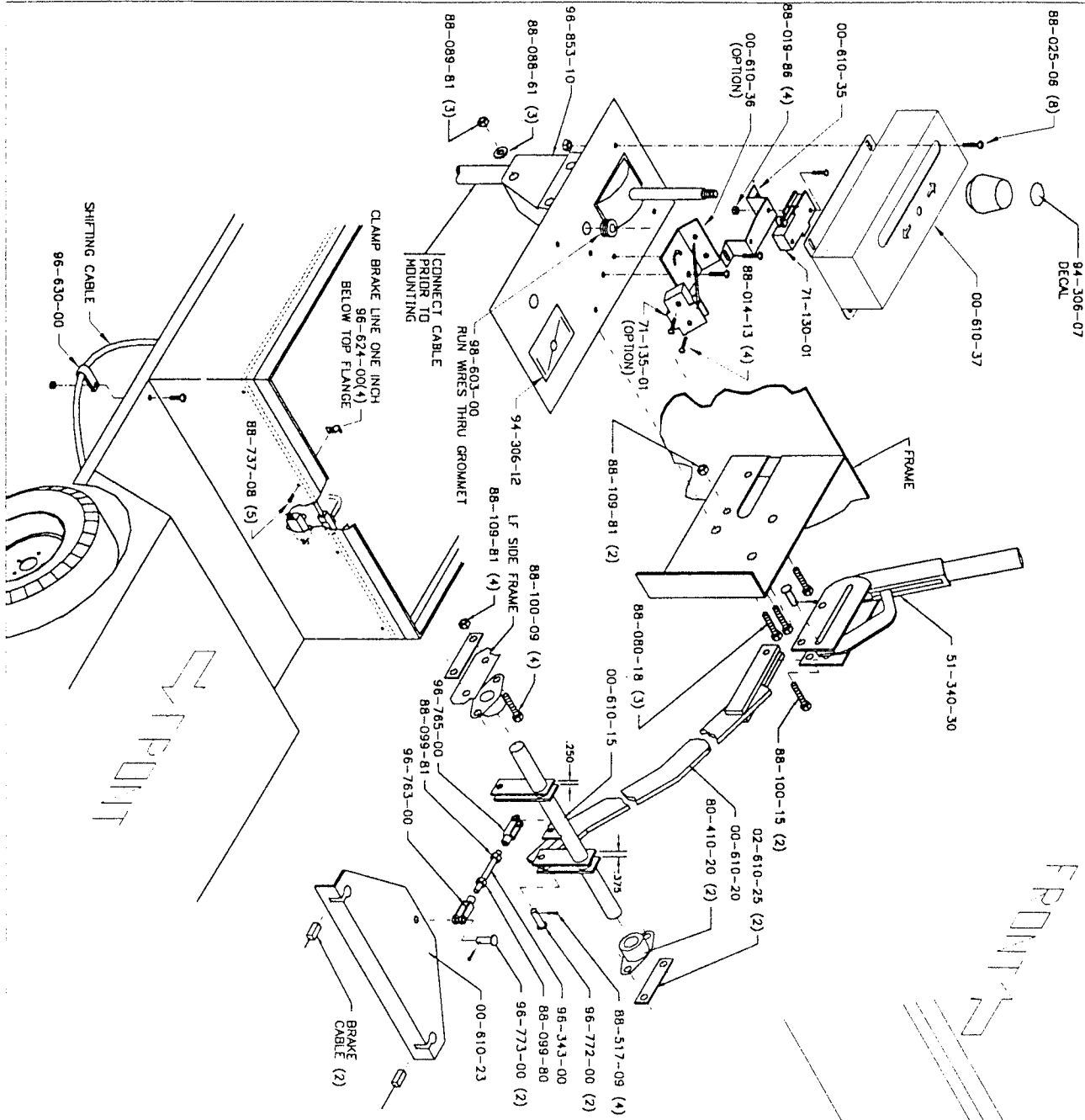

## DECAL LOCATIONS

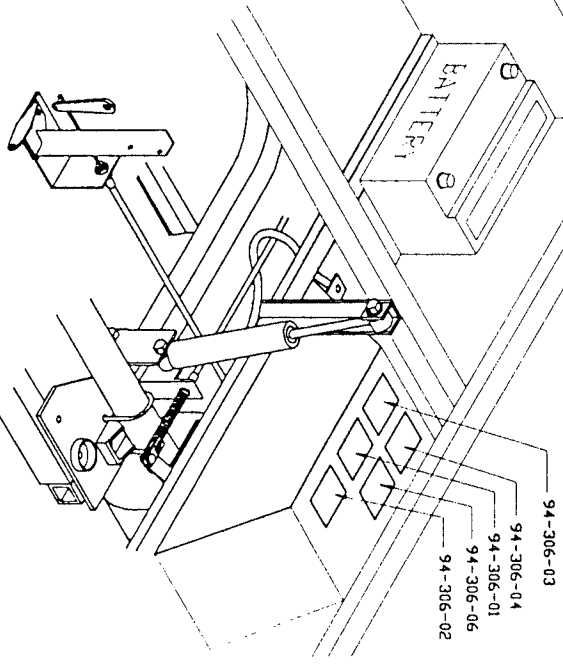

### SHIFTING TEST

1. Move the shifter lever into the neutral position.
2. Engage and verify the parking brake is functioning. Chock all wheels.
3. Hand rotate the pulley to verify the transmission is in the neutral position.
4. Temporarily bypass the neutral start switch by jumping the switch terminals.
5. Start the engine.
6. Slowly move the shifting lever forward until the transmission makes some gear grinding noise. The grinding noise signifies that it is about to engage. Place a mark on the shifter at the location of this initial forward engagement.
7. Perform the same steps in the reverse direction.
8. The initial engagement points should be about equal distance from the neutral position. If they are off, adjust the cable position on the L-bracket.
9. If the cable runs out of adjustment, relocate the L-bracket to the other two holes. Do not bend the L-bracket.

DATE	REV. NO.	DESCRIPTION	REV. BY
09/30/97	A	RELEASE FOR PRODUCTION	HV

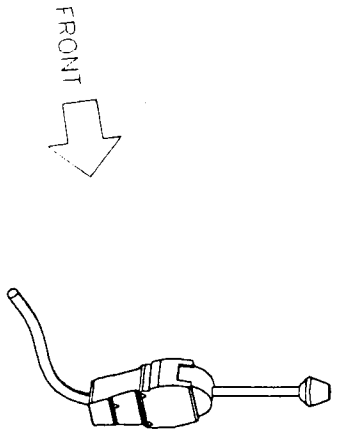

SHIFT CABLE ROUTING

96-851-00  
REF.

FRONT PASSENGER  
SIDE LEAF SPRING  
REF.

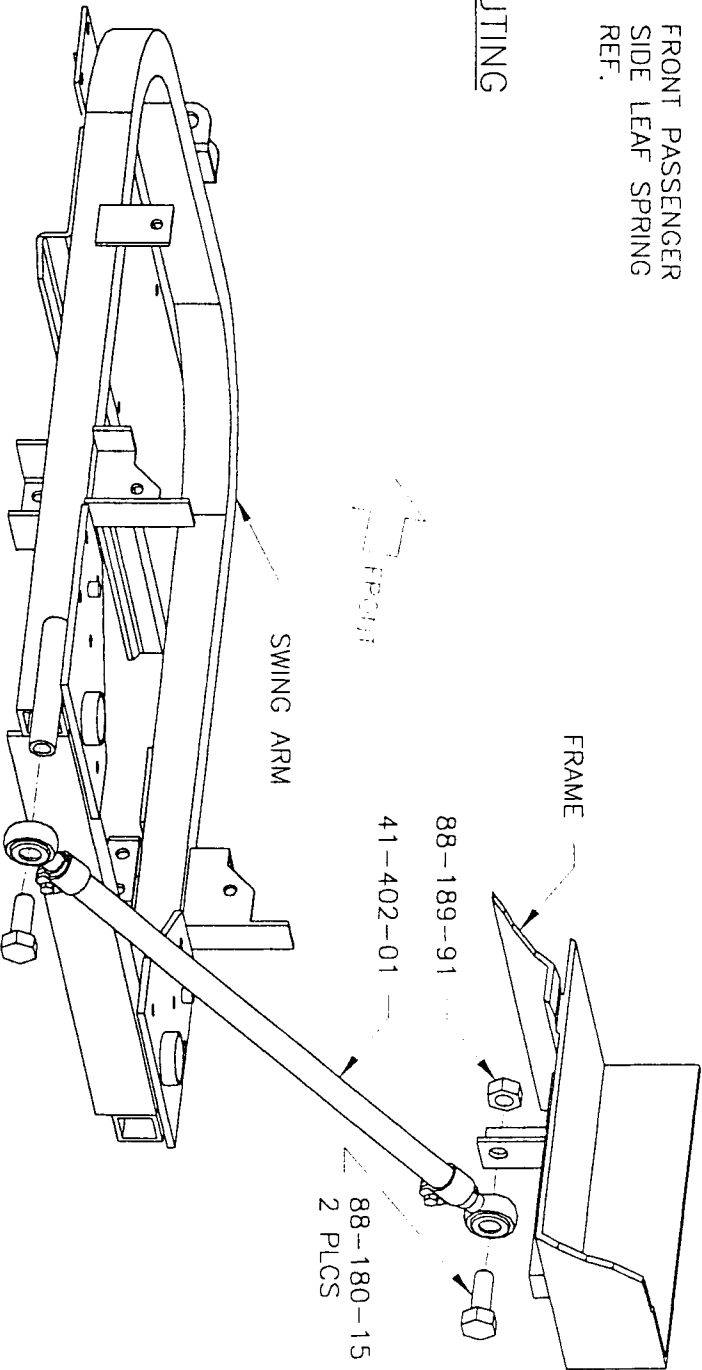

SWING ARM INSTALLATION

TAYLOR-DUNN  
2144 WEST BELL ROAD  
MILWAUKEE, WISCONSIN 53204

TELEPARTS  
REGULAR PRICE \$10.00  
XX-108  
XX-1031

DRIVE, HYDRAULIC  
ONAN 14 HP

SCALE: N.T.S.  
DRAWING BY: WG  
DRAWING SIZE: A  
CG 1101 SCALE

B6-103-15  
PG 3 OF 3



To: Distribution

From: Kevin Hunter

RE: ENGINEERING RELEASE

Date: October 16, 1997

DATE PART # SEQ # DESCRIPTION CHANGE

10/16/97	00-610-49		Drive, 14 HP Onan	Created item and package.
10/16/97	00-610-52		Weldment, Swing Arm	Created item and package.
10/16/97	00-610-80		Linkage, Drive, Dana	Created item and package.
10/16/97	00-610-81		Angle, Shift Cable Mount	Created item and package.
10/16/97	00-610-82		Formed Plate, Shift Cable	Created item and package.
10/16/97	00-610-83		Plate, Shift Mount Bracket	Created item and package.
10/16/97	00-610-84		Widmnt, Shift Cable Mount	Created item and package.
10/16/97	02-610-46		Angle, Notched, Swing Arm	Created item and package.
10/16/97	02-610-70		Plate, Shift Gate	Created item and package.
10/16/97	02-610-71		Mount, Gear Shift	Created item and package.
10/16/97	4C-610-20		Drive, FWD/Neutral/Rev w/hyd	Created item and package.
10/16/97	B2-610-40		Standard Parts BG 150	Created item and package.
10/16/97	B6-103-15		Drive, Hyd, Onan	Created item and package.
10/16/97	B6-104-16		Frame, Widmnt BG150	Created item and package.
10/16/97	B6-104-17		Frame, Widmnt, BG 150	Created item and package.
10/16/97	B6-104-18		Frame, Widmnt BG150	Created item and package.

Distribution:

- B. Alexander
- S. Bartlett
- T. Burdette
- R. Connors
- D. Devers
- G. Eschbach
- Ja. Goodwin
- M. Goodwin
- R. Goodwin
- J. Gribble
- M. Jenkins
- B. Molesky
- A. Navarro
- B. Spears
- M. Owens
- H. Perez
- S. Vargas
- D. Vizenor
- J. Whitehouse

# TAYLOR-DUNN

## QUALITY ALERT: Lug Nut Torque Spec.

### TIRE INSTALLATION

1. Using an air impact gun, snug all lug nuts onto wheel hub following the below pattern, (in order from 1 to 4 or 1 to 5 whichever applies).
2. After snugging each lug nut, fully tighten with air impact gun.
2. Set torque wrench to 85 ft-lbs..
3. Verify each nut meets or exceeds 85 ft-lbs. with torque wrench.
4. Manually spin tires to check for tire wobble. If tire wobbles, verify proper installation. If properly installed, notify lead person of situation.

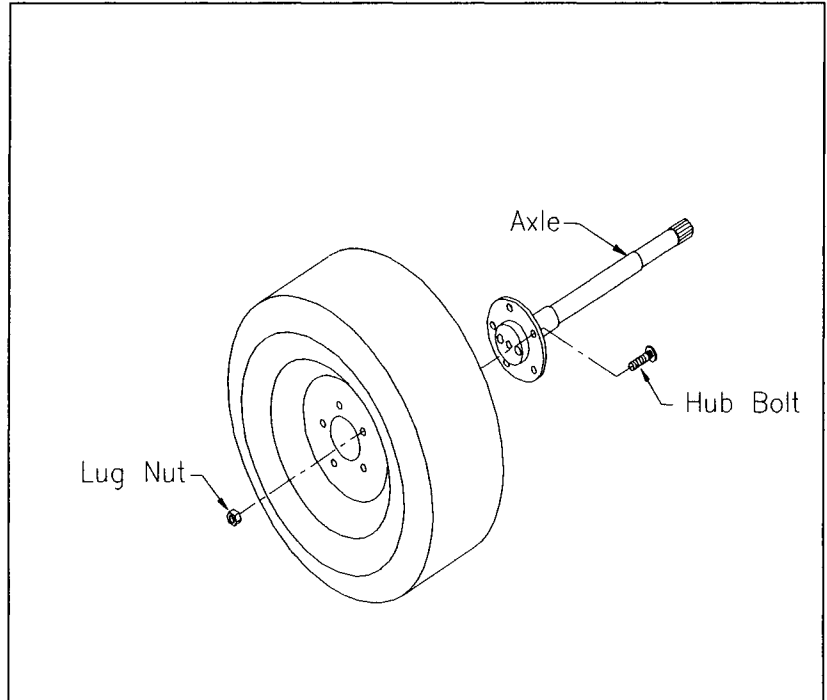

⇒ 4 Lug nut torque pattern ⇒

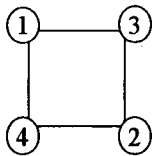

⇒ 5 Lug nut torque pattern ⇒

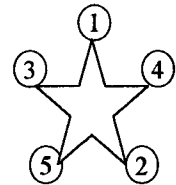

### **Special Notes:**

1. Follow this procedure for each tire attached to the vehicle.

Manufacturing Approval \_\_\_\_\_

Quality Approval \_\_\_\_\_

Location: Assembly

Prepared By: Brian Alexander

Revision Date: August 5, 1997

# TAYLOR-DUNN

## QUALITY ALERT: Leaf Spring Torque Spec.

### Front Suspension

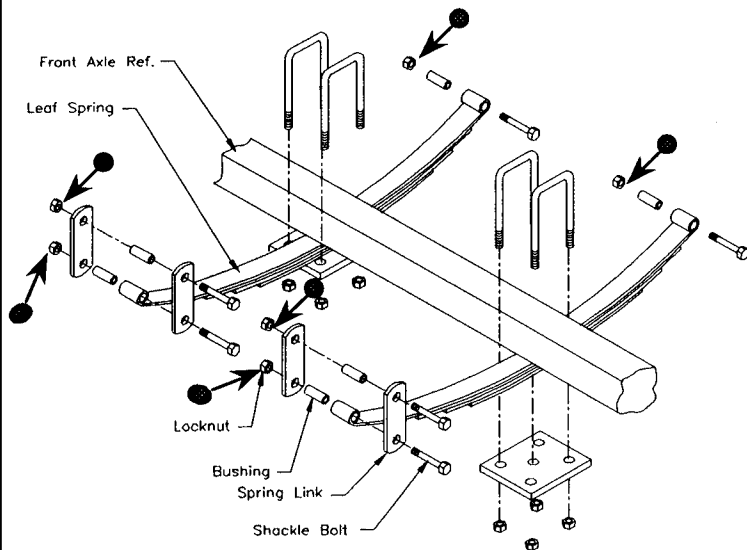

#### LEAF SPRING SHACKLE BOLTS

1. Hold shackle bolt head with wrench to stop rotation.
2. Use an air gun to fully seat locknut.
3. Use appropriate wrench to back off locknut 2 full turns.
4. Ensure torque wrench is properly adjusted to 20ft-lbs.
5. Tighten locknut to 20 ft-lbs. using torque wrench.
6. Repeat for front and rear leaf spring locknuts, (6 plcs.).



Denotes torque location

### Rear Suspension

#### LEAF SPRING SHACKLE BOLTS

1. Hold shackle bolt head with wrench to stop rotation.
2. Use an air gun to fully seat locknut.
3. Use appropriate wrench to back off locknut 2 full turns.
4. Ensure torque wrench is properly adjusted to 20 ft-lbs.
5. Tighten locknut to 20 ft-lbs. using torque wrench.
6. Repeat for front and rear leaf spring locknuts, (6 plcs.).

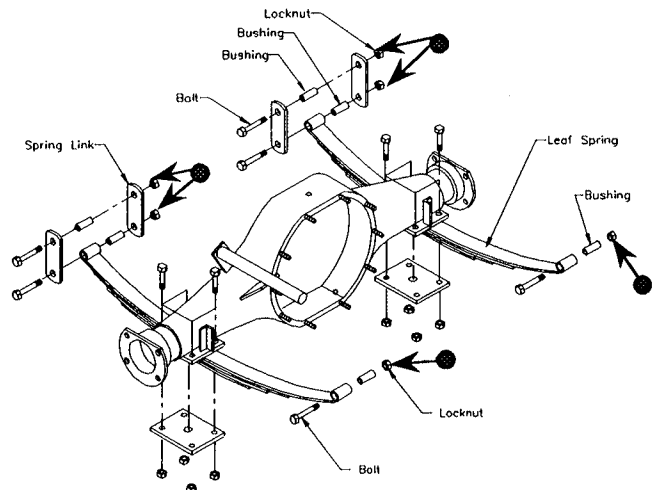

Denotes torque location

### Special Notes:

1. Model B2-10 shown; torque settings and locations apply to all models with a leaf spring suspension.
2. Suspensions not properly installed decrease vehicle performance and most importantly, **CUSTOMER SATISFACTION.**

Manufacturing Approval \_\_\_\_\_

Quality Approval \_\_\_\_\_

Location: Assembly

Prepared By: Brian Alexander

Revision Date: August 21, 1997

torque wrench to the steering wheel nut (Fig. 30). With the steering wheel off center, read the pull required to rotate the input shaft approximately  $1\frac{1}{2}$  turns either side of center. If the torque or preload is not within specification (Part 3-6), adjust as explained in the next step.

8. Loosen the steering shaft bearing adjuster lock nut, and tighten or back off the bearing adjuster (Fig. 29) to bring the preload within the specified limits.

9. Tighten the steering shaft bearing adjuster lock nut, and recheck the preload.

10. Turn the steering wheel slowly to either stop. Turn gently against the stop to avoid possible damage to the ball return guides. Then rotate the wheel  $2\frac{1}{4}$  turns to center the ball nut.

11. Turn the sector adjusting screw clockwise until the specified pull (Part 3-6) is necessary to rotate the worm past its center high spot (Fig. 30). No perceptible backlash is permissible at  $30^\circ$  on either side of center.

12. While holding the sector adjusting screw, tighten the locknut to specification and recheck the backlash adjustment.

13. Connect the Pitman arm to the sector shaft and torque to specification.

#### CHECK POWER STEERING RESERVOIR FLUID LEVEL

Start the engine, turn the steering wheel all the way to the left and

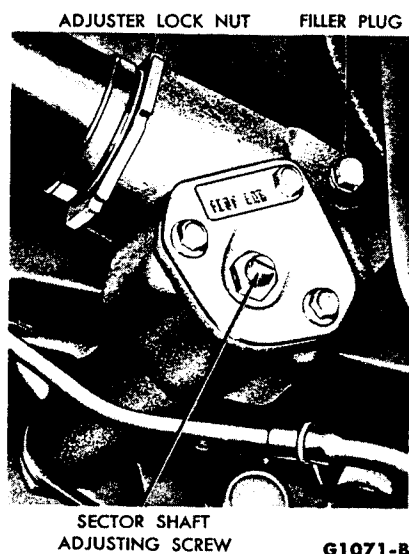
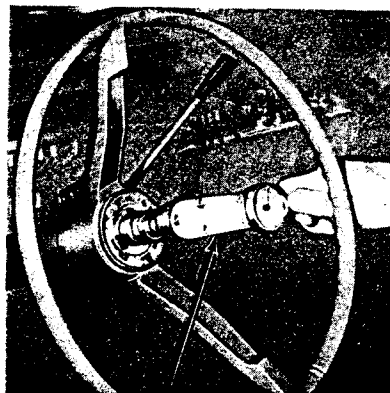

FIG. 29—Typical Steering Gear Adjustments



Torque Wrench (In. Lb.) G 1270 - B

#### FIG. 30—Checking Pre-Load

right several times, and shut off the engine.

Check the fluid level in the reservoir. If the level is low, add enough fluid to raise the level to the bottom of the filler neck. Do not overfill the reservoir.

#### CHECK BRAKE MASTER CYLINDER FLUID LEVEL

1. Remove the filler cap from the master cylinder. The diaphragm which seals the master cylinder should come off with the cap.

2. Fill the reservoir to  $\frac{3}{8}$ -inch from the top.

3. Install the filler cap, making sure that the diaphragm is properly seated in the cap.

#### CHECK BRAKE LINES AND LINING DRUM BRAKES

Raise all four wheels. Remove one of the front brake drums, and inspect the drum and the linings (the wheel bearings should be inspected at this time and repacked if necessary). Do not let oil or grease touch the drum or the linings. If the linings are worn to within  $\frac{1}{32}$  inch of the rivet heads, replace or reline both sets (primary and secondary) on the front or rear wheels. Under no circumstances replace one lining only, or one wheel set. Both front wheel sets or both rear wheel sets should be replaced whenever a respective lining or shoe is worn or damaged. If the drum braking surface is excessively scored, refinish it. The condition of the remaining front linings is usually about the same as that of the one inspected. The rear brake linings may also need replacing at the same time.

#### FRONT WHEEL DISC BRAKES

Raise all four wheels. Remove one

of the front wheel and tire assemblies, and inspect the rotor, caliper, and linings (the wheel bearings should be inspected at this time and repacked if necessary). Do not let oil or grease touch the drum or the linings. If the linings are worn to within 0.030 inch of the surface of the shoe, replace both sets of shoe and lining assemblies (inboard and outboard) on the front wheels. Under no circumstances replace one shoe and lining assembly only, or one wheel set. Both front wheel sets should be replaced whenever a respective shoe and lining is worn or damaged.

If the rotor braking surface is excessively scored, distorted, warped, worn, or shows runout over 0.0013 inch, it should be replaced. If the caliper is cracked or otherwise damaged, it must be replaced as a unit.

With the parking brakes in the fully released position, check the brake cables. The cable adjustment should be just tight enough to remove the slack. Excessive tightening may pull the brake shoes off their anchors.

Check all brake lines for leakage or physical damage and replace or repair as required.

#### CLEAN AND PACK FRONT WHEEL BEARINGS DRUM BRAKES

1. Raise the car until the wheel and tire clear the floor.

2. Remove the wheel cover or hub cap. Remove the grease cap from the hub. Remove the cotter pin, nut lock, adjusting nut, and flat washer from the spindle. Remove the outer bearing cone and roller assembly.

3. Pull the wheel, hub, and drum assembly off the wheel spindle.

4. Remove the grease retainer and the inner bearing cone and roller assembly from the hub with a drift.

5. Clean the lubricant off the inner and outer bearing cups with solvent and inspect the cups for scratches, pits, excessive wear, and other damage. If the cups are worn or damaged, remove them with a drift.

6. Soak a new grease retainer in light engine oil at least 30 minutes before installation. Thoroughly clean the inner and outer bearing cones and rollers with solvent, and dry them thoroughly. Do not spin the bearings dry with compressed air.

7. Inspect the cone and roller assemblies for wear or damage, and