

**OPERATION**  
**AND**  
**MAINTENANCE**  
**MANUAL**  
**WITH**  
**PARTS LIST**

MODEL: R3-80  
SERIAL NO: 99001 to 130187  
Year: 10/91 & 1/99  
MANUAL NO: MR-380-24

**\*\*IMPORTANT\*\***

READ AND FOLLOW INSTRUCTIONS GIVEN IN SAFETY AND OPERATIONS SECTIONS, AND THOSE SECTIONS RELATED TO YOUR SERVICE AND REPAIR RESPONSIBILITIES.



**TAYLOR-DUNN**<sup>®</sup>  
Commercial and Industrial Vehicles Since 1949

2114 W. Ball Rd., Anaheim, CA 92804 (714) 956-4040 (FAX) (714) 956-0504  
Mailing Address: P.O. Box 4240, Anaheim, California 92803

Visit our Website: [www.taylor-dunn.com](http://www.taylor-dunn.com)

## Table of Contents

<b>SECTION 1: INTRODUCTION</b> . . . . .	<b>1</b>
ABOUT THIS MANUAL . . . . .	2
NOTATIONAL CONVENTIONS . . . . .	3
VEHICLE DESCRIPTION . . . . .	4
STANDARD SPECIFICATIONS . . . . .	5
TAKING DELIVERY OF YOUR VEHICLE . . . . .	6
Inspecting the Vehicle . . . . .	6
Checking the Controls . . . . .	6
What To Do If You Find A Problem . . . . .	6
<b>SECTION 2: VEHICLE OPERATION</b> . . . . .	<b>7</b>
SAFETY RULES AND GUIDELINES . . . . .	8
VEHICLE CONTROLS . . . . .	9
DRIVER TRAINING PROGRAM . . . . .	10
Driver Qualifications . . . . .	10
OPERATION . . . . .	11
Driving . . . . .	11
Loading and Unloading . . . . .	11
Parking . . . . .	11
Towing . . . . .	11
<b>SECTION 3: SCHEDULED MAINTENANCE</b> . . . . .	<b>13</b>
MAINTENANCE CHECKLIST . . . . .	15
LUBRICATION CHART . . . . .	16
TROUBLESHOOTING GUIDE . . . . .	17
RECOMMENDED SPARE PARTS . . . . .	19
SPECIAL TOOLS . . . . .	20
ADDITIONAL MAINTENANCE DURING BREAK-IN PERIOD . . . . .	21
BATTERY . . . . .	21
Servicing . . . . .	21
Charging . . . . .	21
Storing . . . . .	21
Replacing . . . . .	21
BRAKES . . . . .	21
Brake Linkages . . . . .	21
MASTER CYLINDER . . . . .	22
TIRES . . . . .	22

<b>SECTION 4 : SERVICE PROCEDURES</b> . . . . .	<b>23</b>
<b>MECHANICAL BRAKE SYSTEM</b> . . . . .	24
Adjusting the Brake Pedal Linkage . . . . .	24
Adjusting the Parking Brake Linkage . . . . .	24
Rear Brakes (Mechanical) . . . . .	25
Replacing the Disc Brake Assembly . . . . .	25
Replacing Brake Pads . . . . .	26
<b>HYDRAULIC BRAKE SYSTEM (Optional)</b> . . . . .	27
Brake Lines . . . . .	27
Manually Bleeding Brake Lines . . . . .	27
Using a Brake Bleeder . . . . .	28
Brake Pedal Linkage (Hydraulic) . . . . .	29
Parking Brake Linkage (Hydraulic) . . . . .	29
Master Cylinder . . . . .	30
Rear Brakes (Hydraulic) . . . . .	31
Replacing Hydraulic Brake Assembly . . . . .	31
Replacing Brake Pads (Hydraulic) . . . . .	31
<b>FRONT AXLE</b> . . . . .	32
Adjusting Front Wheel Bearings . . . . .	33
Aligning the Front End . . . . .	34
Repairing Kingpins and Bushings . . . . .	35
Replacing Rod Ends . . . . .	37
Replacing the Steering Assembly . . . . .	38
Adjusting Steering Wheel Play . . . . .	39
<b>REAR AXLE ASSEMBLY</b> . . . . .	40
Drive Belts and Chains . . . . .	40
Adjusting Drive Belt Tension . . . . .	40
Replacing Drive Belts . . . . .	41
Adjusting Drive Chain (Optional) . . . . .	41
Motor . . . . .	42
Removing the Motor (Power Traction) . . . . .	42
Installing the Motor (Power Traction) . . . . .	42
Power Traction Assembly . . . . .	43
Disassembling the Power Traction Assembly . . . . .	43
Assembling the Power Traction Assembly . . . . .	43
Rear Axle Bearings . . . . .	43
Removing Rear Axle Bearings . . . . .	43
Installing Rear Axle Bearings . . . . .	43

**SECTION 4 : SERVICE PROCEDURES (continued)**

Differential . . . . .	44
Disassembling the Differential . . . . .	44
Assembling the Differential . . . . .	44
Selecting Drive Pinion Shims . . . . .	46
<b>ELECTRICAL SYSTEM . . . . .</b>	<b>47</b>
Overall Electrical System . . . . .	47
Batteries . . . . .	50
Battery Chargers . . . . .	51
Lestronic Battery Chargers . . . . .	51
Installation . . . . .	52
Normal Operation . . . . .	52
Charger Troubleshooting . . . . .	52
No Transformer Hum . . . . .	52
Transformer Hums But No Output . . . . .	52
Charger Output is Low . . . . .	53
Charger Does Not Turn Off . . . . .	53
AC Input Circuit Breaker Blows . . . . .	53
<b>ELECTRICAL CONTROLS . . . . .</b>	<b>54</b>
Solenoid Assembly . . . . .	55
Testing the Accelerator Module . . . . .	56
Testing for Solenoid and Keyswitch Operation . . . . .	57
Speed Controller . . . . .	58
Testing Speed Controller Wiring . . . . .	58
Testing Controller Output . . . . .	59
Checking the Plug Diode . . . . .	60
Checking the Freewheeling Diode . . . . .	60

**SECTION 5: ILLUSTRATED PARTS BREAKOUT . . . . . 61**

MECHANICAL BRAKE LINKAGE . . . . .	62
HYDRAULIC BRAKE LINKAGE AND FLUID SYSTEM . . . . .	64
CHARGERS . . . . .	68
FRONT AXLE . . . . .	70
FRONT AXLE WITH HYDRAULIC DISC BRAKES . . . . .	72
FRONT AXLE SUSPENSION . . . . .	76
INSTRUMENT PANEL . . . . .	78
MASTER CYLINDER . . . . .	80
MOTOR . . . . .	82
REAR AXLE DIFFERENTIAL FOR MECHANICAL DISC BRAKES . . . . .	84

REAR AXLE DIFFERENTIAL FOR HYDRAULIC DISC BRAKES . . . . .	86
REAR AXLE PULLEY, MOTOR MOUNTS . . . . .	88
POWER TRACTION DRIVE . . . . .	90
REAR AXLE SUSPENSION . . . . .	92
REAR MECHANICAL BRAKES . . . . .	94
REAR HYDRAULIC BRAKES . . . . .	96
SPEED CONTROL . . . . .	98
STEERING ASSEMBLY . . . . .	100
VEHICLE OPTIONS . . . . .	102

**LIST OF FIGURES**

<b>LUBRICATION CHART . . . . .</b>	<b>16</b>
<b>FIGURE 1 - BRAKE PEDAL AND PARK BRAKE LINKAGES, MECHANICAL . . . . .</b>	<b>24</b>
<b>FIGURE 2 - MECHANICAL REAR BRAKES . . . . .</b>	<b>26</b>
<b>FIGURE 3 - BRAKE LINKAGE, HYDRAULIC . . . . .</b>	<b>28</b>
<b>FIGURE 4 - PARKING BRAKE LINKAGE, HYDRAULIC . . . . .</b>	<b>29</b>
<b>FIGURE 5 - MASTER CYLINDER . . . . .</b>	<b>30</b>
<b>FIGURE 6 - FRONT AXLE . . . . .</b>	<b>32</b>
<b>FIGURE 7 - FRONT WHEEL HUB ASSEMBLY . . . . .</b>	<b>33</b>
<b>FIGURE 8 - ALIGNING THE FRONT END . . . . .</b>	<b>34</b>
<b>FIGURE 9 - FRONT AXLE KINGPIN ASSEMBLY . . . . .</b>	<b>35</b>
<b>FIGURE 10 - KINGPIN BEARING DETAIL . . . . .</b>	<b>36</b>
<b>FIGURE 11 - FRONT AXLE AND STEERING LINKAGE . . . . .</b>	<b>37</b>
<b>FIGURE 12 - STEERING ASSEMBLY . . . . .</b>	<b>38</b>
<b>FIGURE 13 - FRONT AXLE AND STEERING . . . . .</b>	<b>39</b>
<b>FIGURE 14 - DIFFERENTIAL . . . . .</b>	<b>45</b>
<b>FIGURE 15 - OVERALL ELECTRICAL SYSTEM . . . . .</b>	<b>47</b>
<b>FIGURE 16 - CHASSIS WIRING . . . . .</b>	<b>48</b>
<b>FIGURE 17 - CONTROL MODULE WIRING . . . . .</b>	<b>49</b>
<b>FIGURE 18 - BATTERY CHARGERS, PORTABLE AND BUILT-IN . . . . .</b>	<b>51</b>
<b>FIGURE 19 - CONTROL PANEL ASSEMBLY . . . . .</b>	<b>54</b>
<b>FIGURE 20 - SOLENOID ASSEMBLY . . . . .</b>	<b>55</b>
<b>FIGURE 21 - ELECTRONIC SPEED CONTROLLER . . . . .</b>	<b>58</b>



**Section 1.**

**INTRODUCTION**

## ABOUT THIS MANUAL

This manual provides you with information you need to safely operate and maintain this vehicle. We assume that those who will attempt maintenance operations are trained vehicle service technicians capable of performing routine maintenance procedures such as changing a tire, using a voltmeter, and so forth. We also assume that you have or will attend a training program designed to familiarize you with the safe operation and use of this particular vehicle.

This manual contains the following major sections:

**SECTION 1: INTRODUCTION -** —contains information about how to use this manual, a description of the R3-80, how to perform an incoming inspection, and vehicle specifications.

**SECTION 2: VEHICLE OPERATION** —provides safety rules and guidelines, describes the driver training program, and explains the operation of each control on the R3-80.

**SECTION 3: SCHEDULED MAINTENANCE** — contains a scheduled maintenance checklist, lubrication diagram, troubleshooting guide, recommended spare parts list, and detailed maintenance procedures for the R3-80.

**SECTION 4: SERVICE PROCEDURES** — contains service procedures, in alphabetical order, for each assembly found in the R3-80. Each major heading contains procedures organized in logical order.

**SECTION 5: ILLUSTRATED PARTS** —includes an illustration and parts list for each assembly that has replaceable parts for the R3-80.

## NOTATIONAL CONVENTIONS

The following types of notations are used throughout this manual:

### **WARNING!**

---

A warning alerts you of something that may cause injury to yourself or others. Be sure you exercise special care and follow any instructions provided in a warning message.

---

### **Caution!**

---

A caution informs you of something that may cause damage to the vehicle. Be sure you exercise special care and follow any instructions provided in a caution message.

---

**Note:** *A note provides additional information about a subject.*

**Tip:** *A tip is a suggestion that you might find helpful for a specific procedure.*



## VEHICLE DESCRIPTION

**Note:** *This manual applies to vehicles with serial numbers starting at 99001.*

The R 3-80 is designed to carry passengers and cargo through narrow aisles and over smooth outdoor surfaces. The vehicle provides excellent maneuverability and operational comfort.

The vehicle can handle a total (cargo and passengers) of up to 1,150 lbs. Various options are available to enable you to customize the vehicle to suit your particular needs

(consult your Taylor-Dunn salesperson or representative for current options)

This vehicle conforms to requirements for Type E as described in O.S.H.A. Standard Section 1910.178 (Powered Industrial Trucks) and with all applicable portions of the American National Standard for Personnel and Burden Carriers (ANSI B56.8-1988). The model and serial number for this vehicle are imprinted on a decal located under the right side cowl (inside).

## STANDARD SPECIFICATIONS

ITEM	SPECIFICATION
Dimensions (Length x Width x Height)	243.8 X 112.4 X 118.1 cm
	96 X 44 <sup>1</sup> / <sub>4</sub> X 46 <sup>1</sup> / <sub>2</sub> in
Weight (with batteries below)	544 Kg (1200 lbs)
Turning Radius	317.5 cm (125 in)
Hill Climbing Ability	10% incline
Speed Controller	Stepless solid state controller
Tires	5.70 x 8 load range B pneumatic
Motor	NEMA rated 36 volt, 6 hp (@1200 rpm) intermittent duty to 2 hp (@2800 rpm) normal duty
Battery	Six 220 AH (107 min. rating)
Brakes	Mechanical disc brakes (both rear wheels)

## TAKING DELIVERY OF YOUR VEHICLE

This vehicle should be inspected immediately after delivery. Use the following guidelines to make sure there are no obvious problems.

### Inspecting the Vehicle

- ◆ Examine the contents of all packages that came with this vehicle. Make sure everything listed on the packing slip is there. Nothing should look broken or damaged.
- ◆ Examine any visible wiring for obvious signs of damage. Check that all connections are secure.
- ◆ Check that the battery connections are tight and all cells are filled.
- ◆ Inspect the tires for signs of damage. Check the tire pressure . Make sure that all wheel lugs are secure.
- ◆ Check the body, seats, windshield (optional), trim and other external parts for obvious damage.

### Checking the Controls

Try each of the following controls before turning on the keyswitch:

- ◆ accelerator pedal
- ◆ brake pedal
- ◆ forward - reverse switch
- ◆ parking brake
- ◆ steering wheel
- ◆ horn
- ◆ lights

Each control should move smoothly and easily, without sticking or requiring undue effort.

### What To Do If You Find A Problem

If you find a problem with this vehicle, you must immediately file a claim with the carrier. The claim must be filed within 48 hours of receiving the vehicle. Forward a copy of the damage claim to your Taylor-Dunn dealer.

#### **Caution!**

Do not repair, modify or adjust any part of this vehicle unless you are authorized to do so.



# **Section 2**

## **VEHICLE OPERATION**

## SAFETY RULES AND GUIDELINES

**Note:** *It is the responsibility of the owner of this vehicle to ensure that the operator understands the various controls and operating characteristics of this vehicle, and obeys the following safety rules and guidelines (extracted from the American National Standards Institute, Personnel and Burden Carriers, — ANSI B56.8).*

This vehicle is designed to be driven in and around places such as warehouses, nurseries, motels, parks and resorts. Before you drive this vehicle, please observe the following safety rules and guidelines.

### **WARNING!**

**Do not drive this vehicle on public roads and highways. Do not exceed 15 MPH at any time. Speeds in excess of 15 MPH may cause steering difficulty and loss of control.**

- ◆ Do not drive this vehicle unless you are a qualified operator.
- ◆ Do not drive this vehicle in hazardous areas unless this vehicle is approved and labelled for such operation
- ◆ Drive only on level surfaces or on surfaces having an incline of no more than 10%.
- ◆ Do not drive over loose objects, holes or bumps.
- ◆ Keep the vehicle under control at all times.
- ◆ Keep a clear view ahead at all times.
- ◆ Avoid dangerous activities such as stunt driving or horseplay.
- ◆ Do not drive this vehicle in hazardous areas unless this vehicle is approved for such operation.
- ◆ Immediately report any accident or vehicle problem to your supervisor.



## VEHICLE CONTROLS

**Note:** *Some controls are optional equipment and may not be installed on this vehicle.*

### **Deadman Seat Interlock**

The deadman seat interlock, located under the drivers seat, is designed to allow operation of the vehicle only when the driver is seated.

### **Keyswitch**

A keyswitch, located on the right side of the instrument panel, is designed to secure the vehicle and disable its operation. You cannot remove the key when the keyswitch is in the ON position. Rotate the key clockwise to turn the vehicle on, counterclockwise to turn the vehicle off.

### **Parking brake lever**

The parking brake lever is located to the right of the drivers seat. To set the parking brake, pull up on the lever. Push the button on the end of the lever and push down to release the parking brake .

### **Forward - Reverse Switch**

The forward - reverse switch, located on the instrument panel to the right, determines the direction of travel (forward or reverse) of the vehicle. It is a rocker type switch. Depress the upper part of the switch to go forward. Depress the lower part of the switch to go in reverse. Note that the switch has a center "OFF" position.

### **Accelerator pedal**

The accelerator pedal, located to the right of the brake pedal, controls the speed of the vehicle and is designed for right foot operation. It operates the same as the accelerator pedal in an automobile.

### **Steering**

The steering system is similar to standard automobiles. To turn right, turn the steering wheel clockwise. To turn left, turn the steering wheel counterclockwise .

### **Foot brake pedal**

The foot brake pedal, located to the right of the steering column, is also designed for operation with the right foot. It works the same way as the brake in an automobile. Applying pressure to the brake pedal slows the vehicle according to the amount of pressure applied. Removing your foot from the pedal releases the braking action.

### **Backup warning alarm (optional)**

A warning alarm sounds whenever the vehicle is in reverse, the keyswitch is on, and the accelerator is depressed.

### **Headlight switch (optional)**

A headlight switch, located on the instrument panel, turns the headlight and taillights on or off. It is a rocker type switch. To turn the lights on, push the upper half of the switch. To turn the lights off, push the lower half of the switch.

### **Horn button**

The horn button is located on the floor to the left of the steering column. Depress the button to sound the horn, and release it to silence the horn.

### **Windshield wiper switch (optional)**

The windshield wiper control switch turns the electric windshield wiper on and off. It is a rocker type switch. Push the upper half of the switch to turn on the wiper. Push the lower half of the switch to turn off the wiper.

## DRIVER TRAINING PROGRAM

The owner of this vehicle shall conduct an operator training program for all those who will be operating this vehicle. The training program shall not be condensed for those claiming to have previous vehicle operation experience. Successful completion of the operator training program shall be required for all personnel who operate this vehicle.

The operator training program shall include the following:

- ◆ Operation of this vehicle under circumstances normally associated with your particular environment
- ◆ Emphasis on the safety of cargo and personnel
- ◆ All safety rules contained within this manual
- ◆ Proper operation of all vehicle controls
- ◆ A vehicle operation and driving test

Only those who have successfully completed the operator training program are authorized to drive this vehicle. Operators must possess the visual, auditory, physical and mental ability to safely operate this vehicle as specified in the American National Standards Institute, Personnel and Burden Carriers — ANSI B56.8.

---

### Qualifications Of Driver

---

The following are the minimum requirements necessary to qualify as an Operator of this vehicle:

- ◆ Demonstrate a working knowledge of each control
- ◆ Understand all the safety rules and guidelines presented in this manual
- ◆ Know how to properly load and unload cargo
- ◆ Know how to properly park this vehicle
- ◆ Recognize an improperly maintained vehicle
- ◆ Demonstrate the ability to handle this vehicle in all conditions likely to be encountered.

*Extracted from the American National Standards Institute.*

---

## OPERATION

---

### Driving

---

- ◆ Keep all body parts (head, arms, legs) inside this vehicle while it is moving.
- ◆ Maintain a safe distance from all objects.
- ◆ Do not overtake another vehicle at intersections, blind spots or other dangerous locations.
- ◆ Slow down and sound the horn when approaching a corner or other blind intersection
- ◆ Drive slowly when making a turn, especially if the ground is wet, slippery, or when driving on an incline.

---

### **WARNING!**

---

**This vehicle may overturn easily if turned sharply when driving, especially when on an incline.**

---

- ◆ Use the brakes to stop the vehicle on an incline - do not stop by reversing direction of motion as this will cause motor damage.
- ◆ Yield the right of way to pedestrians, ambulances, fire trucks or other vehicles in emergency situations.
- ◆ Observe all traffic regulations and speed limits.
- ◆ Keep to the right under normal conditions

---

### Loading and Unloading

---

- ◆ Do not load cargo that can easily fall off this vehicle.
- ◆ Do not exceed the cargo load capacity of this vehicle.
- ◆ Do not carry more than the maximum number of passengers allowed for this vehicle.
- ◆ Be extra careful when handling cargo that is longer, wider or higher than this vehicle.

---

### Parking

---

- ◆ Set the parking brake before leaving the vehicle
- ◆ If you will be away from this vehicle, put the forward/reverse shift lever in the off position, set the parking brake, turn off the keyswitch and remove the key
- ◆ If you park this vehicle on an incline, block the wheels; use only the brakes to stop the vehicle on an incline
- ◆ Do not block fire aisles, fire equipment or stairways

---

### Towing

---

- ◆ To tow this vehicle, attach a tow strap to the front bumper tow bar and place the forward/reverse shift lever in the neutral position.
- ◆ Use another driver to steer this vehicle while it is being towed; be sure the driver uses the brakes when you slow or stop the towing vehicle.

---

### **WARNING!**

---

**Do not exceed 5 MPH or carry any passengers while towing this vehicle.**

---



**This page is intentionally left blank.**



**Section 3**  
**SCHEDULED MAINTENANCE**

This section explains how to perform the scheduled maintenance procedures. Use the Maintenance Checklist to determine how often you should perform each procedure.

This section contains the following:

- ◆ Maintenance checklist
- ◆ Lubrication chart
- ◆ Troubleshooting guide
- ◆ Recommended spare parts list
- ◆ Special Tools
- ◆ Detailed maintenance procedures

**MAINTENANCE CHECKLIST**

The following table outlines those items on the vehicle which should be checked on a periodic basis. The intervals are given in calendar time and hours of operation. Each maintenance item should be performed when the first of the two limits is reached. For example, even if the vehicle is only operated 10 hours per week, the items shown in the "Weekly" column should be performed every week.

<b>PERIODIC MAINTENANCE CHECKLIST</b>					
<b>Maintenance Item</b>	<b>Weekly (30 hrs)</b>	<b>Monthly (120 hrs)</b>	<b>Quarterly (360 hrs)</b>	<b>Semi- yearly (720 hrs)</b>	<b>Yearly (1440hrs)</b>
*Check and adjust brake system .	-	✓	-	-	-
*Lubricate front wheel bearings (2 zerk fittings)	-	-	-	✓	-
*Check brake lining for wear.	-	-	✓	-	-
*Adjust front bearings.	-	-	✓	-	-
*Lubricate steering gear box.	-	-	-	✓	-
Check and fill batteries (use distilled water only).	✓	-	-	-	-
Wash batteries with water (use baking soda if necessary)	-	-	✓	-	-
Check motor brushes	-	-	-	-	✓
Check tire pressure	✓	-	-	-	-
Check front end alignment and rod ends	-	-	✓	-	-
Lubricate all Zerk fittings.	-	✓	-	-	-
Lubricate all moving parts without Zerk fittings (use all-purpose oil).	-	-	✓	-	-
Clean and tighten all wire connections.	-	-	✓	-	-
Drain rear axle differential ; refill with SAE 30 oil.	-	-	✓	-	-
Clean and repack front wheel bearings (use wheel bearing grease)	-	-	-	-	✓
<b>NOTE:</b> Items with an asterisk (*) are related to safety.					

# LUBRICATION CHART

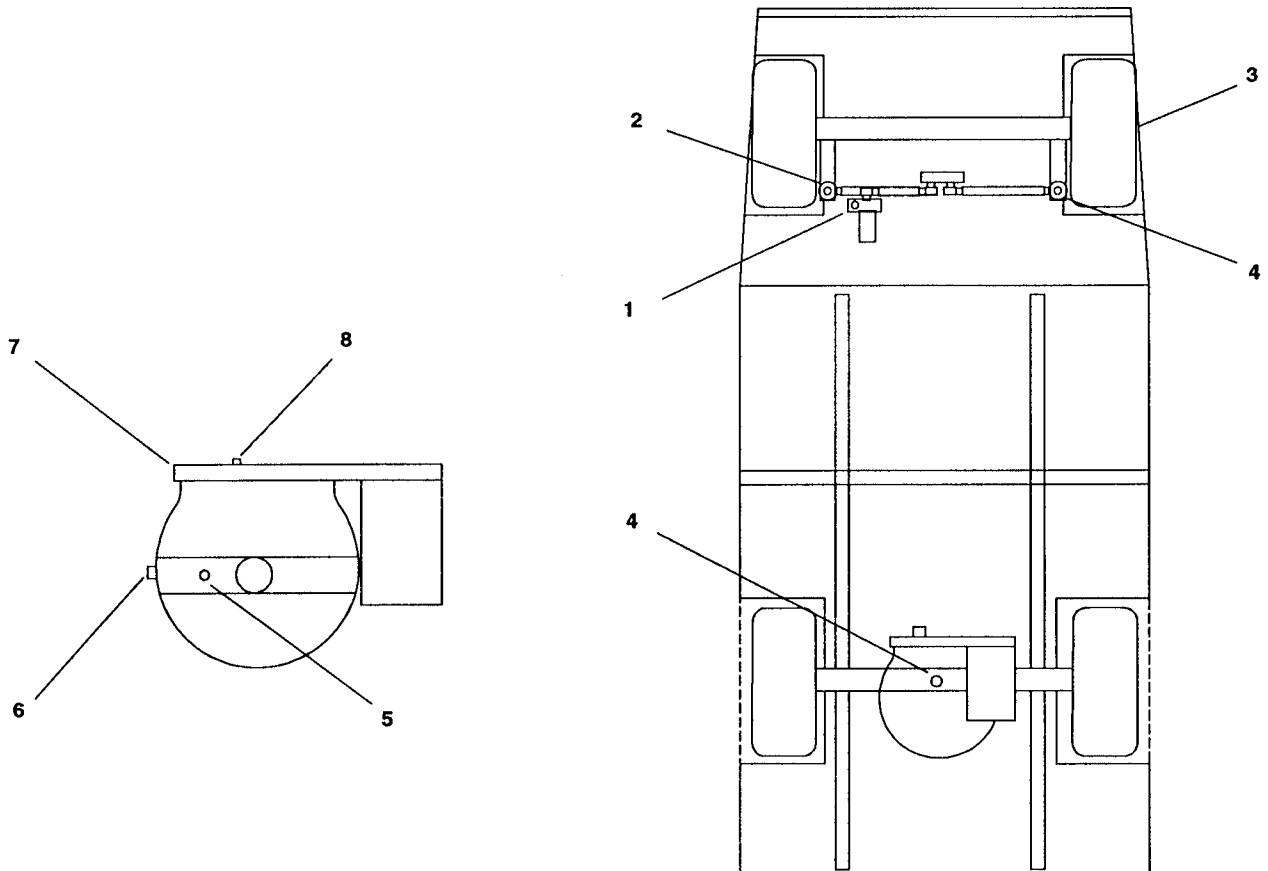

Item #	Description	No. of Locations	Lubricant
1	Steering Gear Box	1	General Purpose Grease
2	Steering Ball Joints	3	
3	Front Wheel Bearings	2	
4	Rear Axle Filler Plug	1	SAE 30 Non-detergent Motor Oil
5	Rear Axle Level Plug	1	
6	Rear Axle Drain Plug	1	
7	Drive Chain Level/Filler Plug	1	SAE 30 Non-detergent Motor Oil
8	Drive Chain Drain Plug	1	

NOTE: Items 7 and 8 do not apply to belt drive systems.

## TROUBLESHOOTING GUIDE

SYMPTOM	PROBABLE CAUSE	CORRECTIVE ACTION
Steering pulls in one direction	Loose wheel bearing	Adjust wheel bearing
	Low tire pressure	Inflate tires to correct pressure
	Loose rod end bolts	Tighten bolts
	Worn rod ends	Replace rod ends
	Loose front axle mounting	Tighten mounting bolts
Hard to steer	Loose wheel bearing	Adjust wheel bearing
	Low tire pressure	Inflate tires to correct pressure
	Worn ball joints	Replace ball joints
	Worn king pin bushings	Replace king pin bushings
	Tight neutral axis bolt	Adjust neutral axis bolt
	Unlubricated neutral axis bolt	Lubricate neutral axis bolt
	Unlubricated steering gear	Lubricate steering gear
	Misadjusted steering gear	Adjust steering gear
	Unlubricated king pin bushings	Lubricate king pin bushings
Brakes feel soft	Air in brake lines	Fill master cylinder and bleed brake lines
	Bad seals in master cylinder	Rebuild or replace master cylinder
	Oil on brake pad lining	Find oil source and correct, replace brake pads
	Dirt on brake pad lining	Clean brake pad lining
	Bind in linkage	Loosen or realign brake linkage
	Loose caliper bolt	Torque to 12 ft lbs
	Weak pedal return spring	Replace pedal return spring
No brakes	Bad seals in master cylinder	Rebuild or replace master cylinder
	Broken connection in linkage	Replace linkage

## TROUBLESHOOTING GUIDE (cont'd.)

SYMPTOM	PROBABLE CAUSE	CORRECTIVE ACTION
Lack of power or slow operation	Dragging brake	Re-adjust brakes
	Tight front wheel bearing	Re-adjust wheel bearing
	Defective rear axle bearing	Replace bearings
	Bind or drag on differential	Repair differential
	Corroded battery connections	Clean or replace
	Defective or worn motor brushes	Clean or replace
	Low battery voltage	Fill and charge battery or replace battery
	Loose wire connections	Check wires and connections
	Defective Controller	Replace controller
	Defective accelerator module	Replace accelerator module
Motor does not run	Motor or solenoids	Check motor and solenoids
	Dead battery	Replace or recharge battery
	Loose wire connections	Check wires and connections
	No continuity through motor	Repair or replace motor
Controller does not operate	Loose wire connections	Check wires and connections
	No accelerator output	Replace accelerator
	Defective seat switch	Replace seat switch
	Defective keyswitch	Replace keyswitch
	Low battery voltage	Charge battery
Thump or grinding noise in drive axle	Motor bearing	Replace motor bearing
	Loose motor on base	Tighten and adjust motor
	Defective gears in differential	Replace gears
	Defective bearing in differential	Replace bearing

## RECOMMENDED SPARE PARTS

The following table lists the parts that are recommended to have on site to allow timely repair of the vehicle. These parts can be purchased from your local dealer or Taylor-Dunn directly.

PART #	DESCRIPTION	QTY.
13-742-00	Tire and Wheel Assembly, 5.70 x 8	1
62-033-00	Accelerator Module	1
62-204-00	Speed Controller	1
71-039-00	Forward/Reverse Switch	1
71-111-00	Brake Light Switch (Mechanical Brakes)	1
71-120-00	Keyswitch	1
71-102-15	Switch, Push Button w/Seal	1
72-501-36	Solenoid, SPST, 36 volt, 100 amp	1
72-501-39	Solenoid, SPDT, 36 volt, 100 amp	2
73-004-20	Horn, 12 volt	1
71-122-20	Switch, Horn	1
80-017-00	Tapered Bearing, 1"	4
80-410-20	Flange Bearing, .750"	4
86-518-00	Rod End, Studded, Right Hand	3
86-518-01	Rod End, Studded, Left Hand	3
85-233-00	Spring, Brake Return	1
41-348-70	Pad, Disk Brake	4
72-025-00	Light, Tail and Stop	2
98-200-00	Brake Pedal Pad, Rubber	1
98-254-00	Accelerator Pedal, Aluminum	1
NOTE: The quantity indicated is per vehicle		



## SPECIAL TOOLS

The following table lists tools which may be unique and will aid in the troubleshooting of the vehicle.

MAINTENANCE PROCEDURE	USE THIS TOOL:	TO DO THIS:
Electrical Service	Mutimeter	Check electrical system
	Hydrometer	Measure the specific gravity of the battery electrolyte
	Accelerator Module Test Box (62-027-30)	Check accelerator and connections
	Test Light (62-027-00)	Check controller output
	High Current Ammeter	Check motor current

---

### **Additional Maintenance During the Breakin Period**

---

Additional maintenance may be required during the breakin period to correct for the initial seating-in of components. The following items should be checked several times during the breakin period to insure that proper adjustment is maintained:

- 1** Drive chain or belt
- 2** Brakes and parking brake linkage.

---

### **Batteries**

---

The batteries should be checked for proper electrolyte level and cleaned to maintain optimum charge. Do not allow the electrolyte level to get low or the battery to remain dirty.

- 1** Check the electrolyte level, fill with distilled water up to the correct level.
- 2** Clean the batteries with water. Thoroughly dry the battery surface using dry rags.

---

#### **Caution**

---

Do not overfill the batteries. If the top of the batteries appears wet before you fill or wash it, it is probably due to leaky or loose cell covers. Tighten or replace covers.

---

- 3** Clean the cell posts, connectors and steel tray with water.

---

#### **Caution**

---

While cleaning the batteries make certain to keep solenoids, controller and battery charger from getting wet or damp.

---

### **Charging The Batteries**

---

#### **Caution**

---

Do not use a high amperage boost charger.

---

---

#### **Caution**

---

Do not reverse the battery cables.

---

### **Storing The Batteries**

Always charge the batteries before storing for long periods and recharge every two months. Store batteries at moderate temperatures (50 - 75 degrees F). Batteries which are stored at extremes in temperature, either hot or cold, will provide a shorter service life than those stored at moderate temperatures.

### **Replacing Batteries**

Care must be taken when replacing batteries to ensure that they are not damaged and that their output terminals are not shorted. It is advisable that the negative (-) lead from the battery be disconnected first when removing the battery and be the last connected when replacing the battery.

---

## Brakes

---

---

### Brake Linkages

---

Visually inspect the brake linkages for signs of wear or cracks. Visually inspect the clevis pin connections for excessive wear.

---

#### **Caution!**

Replace any worn or damaged parts immediately.

---

---

### Brake Hoses and Lines (Optional Hydraulic Disc Brakes)

---

Visually inspect the brake hoses and lines for signs of leakage, wear or cracks.

---

#### **Caution!**

Replace any worn or damaged lines or hoses immediately.

---

---

### Master Cylinder (Optional Hydraulic Disc Brakes)

---

Remove the master cylinder cap and check the brake fluid level. The fluid should be within  $\frac{3}{8}$ " to  $\frac{1}{2}$ " from the top of the fill port.

**Note:** *The cylinder cap is accessible by removing the passenger seat. The cap is located between the batteries.*

---

#### **Caution!**

Use only DOT #5 brake fluid. If the brake fluid becomes contaminated, flush the system with clean DOT #5 fluid then refill the master cylinder and bleed brake system.

---

---

### Tires

---

Inspect the tires by performing the following:

- 1** Check the tires for nicks or grooves and replace if necessary.
- 2** Ensure that the tire is properly seated on the rim.
- 3** Ensure that all the lug nuts are installed and secure.
- 4** If the tires are pneumatic, check for proper inflation.



**Section 4**  
**SERVICE PROCEDURES**

## MECHANICAL BRAKE SYSTEM

The mechanical brake system consist of:

- ◆ Brake pedal and linkage
- ◆ Hand brake and linkage
- ◆ Rear brakes

### Adjusting the Brake Pedal Linkage

**Note:** *The brake pads and discs should be inspected before any adjustments are made. Replace any worn or damaged parts before making any adjustments.*

To adjust the brake pedal linkage, perform the following:

- 1** Loosen the jam nuts at the clevises on the brake rods.
- 2** Turn the brake rod until the linkage is as tight as possible without any detectable brake drag.
- 3** Tighten the jam nuts while making sure the brake rod does not turn.
- 4** Test drive the vehicle to insure that the rear brakes operate evenly. An adjustment may be required in one brake rod to allow for even braking.

### Adjusting the Parking Brake Linkage

To adjust the parking brake linkage, perform the following:

**Note:** *The brake pedal linkage must be adjusted before the parking brake linkage is adjusted.*

- 1** Loosen the jam nut on the clevis attached to the parking brake lever.
- 2** Remove the clevis pin from the clevis.
- 3** Turn the clevis to shorten or lengthen the rod assembly so that when re-installed, the parking brake lever locks in the second to fifth position.

**TIP:** *Turning the clevis clockwise will make the parking brake lever lock in a lower position.*

- 4** Install the cotter pin and tighten clevis jam nut.

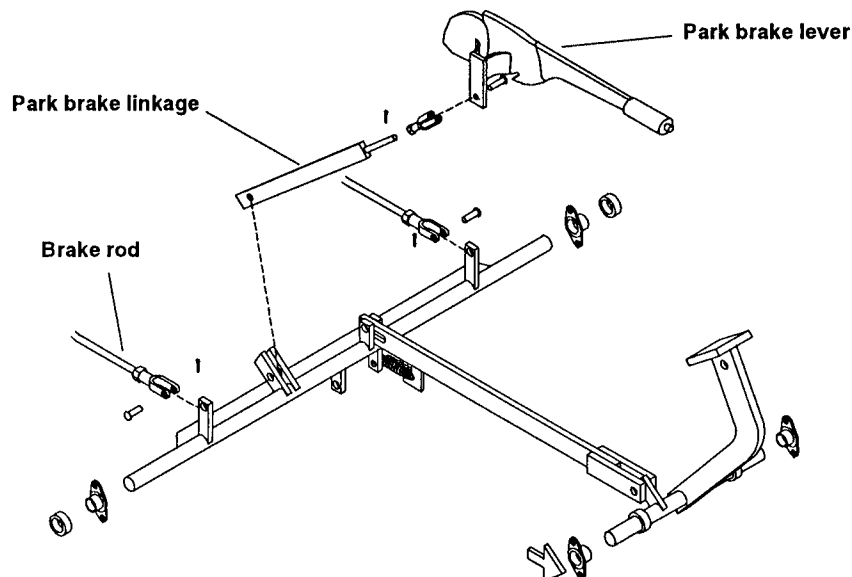

**Figure 1** - Brake pedal and park brake linkages, mechanical

## **Rear Brakes (Mechanical)**

---

Servicing the rear mechanical brakes consists of:

- ◆ Replacing brake assembly
- ◆ Replacing brake pads.

### **Replacing Disc Brake Assembly**

---

To replace the mechanical disc brake assembly, perform the following:

- 1** Raise and support the vehicle.

#### **WARNING!**

**Always use jack stands of adequate capacity when supporting the vehicle. Perform this procedure only on a flat, level surface.**

---

- 2** Disconnect brake rod assembly at the caliper.
- 3** Remove two caliper body bolts that hold pads and spacers to the caliper body.

- 4** Remove brake pads and spacers.
- 5** Replace the spacers if they are flared or cracked.
- 6** Replace bushings if they are worn.

**Note:** *The spacers must fit snugly in the bushings while still allowing the spacers to slide.*

- 7** Remount the caliper body to the brake bracket.
- 8** Install the brake pads and spacers.
- 9** Tighten both caliper body bolts to 12 ft lbs.

**Note:** *Use new locking nuts for the brake body bolts to maximize locking capability.*

- 10** Adjust brake linkage.
- 11** Test drive the vehicle to ensure that the brakes work correctly.

## Replacing Brake Pads

To replace the rear brake pads, perform the following:

- 1** Raise and support the vehicle.

### **WARNING!**

**Always use jack stands of adequate capacity when supporting the vehicle. Perform this procedure only on a flat, level surface.**

- 2** Disconnect the brake rod at the caliper assembly.

- 3** Remove one caliper body bolt and spacer then remove brake pads.
- 4** Replace old brake pads with new brake pads.
- 5** Install the new brake pads, spacer, and caliper body bolt.
- 6** Tighten brake body bolt to 12 ft lbs.
- 7** Adjust and connect the brake rod to the caliper assembly.
- 8** Turn disc by hand and insure that there is no excessive drag.
- 9** Lower vehicle and test drive for proper braking.

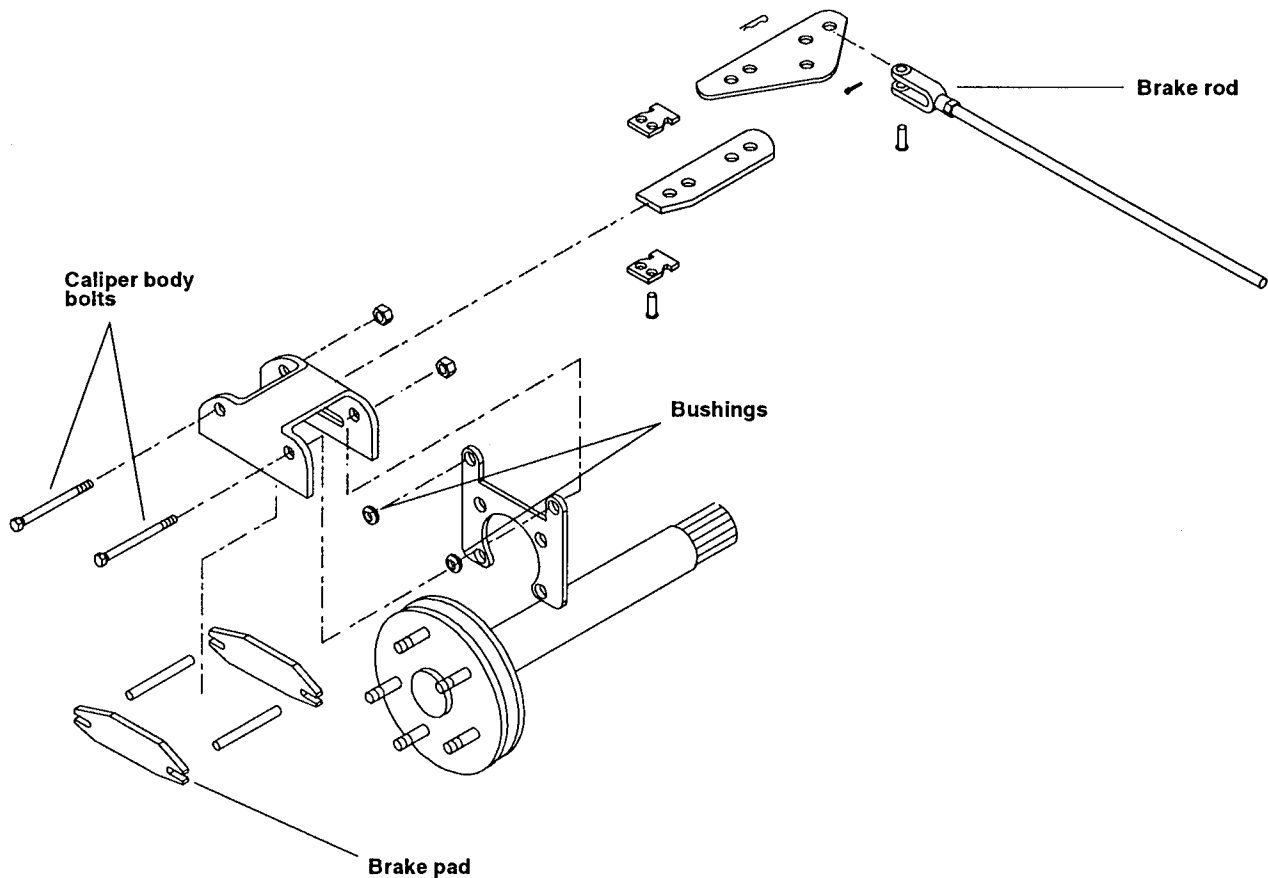

**Figure 2 - Mechanical rear brakes**

## HYDRAULIC BRAKE SYSTEM (OPTIONAL)

The optional hydraulic brake system consists of:

- ◆ Brake lines
- ◆ Brake pedal linkage
- ◆ Parking brake linkage
- ◆ Master cylinder
- ◆ Rear brakes (hydraulic and mechanical)

### Caution!

Do not drive the vehicle if a leak is detected in any part of the hydraulic brake system. The cause of the leak must be repaired immediately.

**Tip:** Check the location of the leak to help determine the defective component.

IF:	TRY THIS:
Brakes feel spongy	<ul style="list-style-type: none"> <li>• bleed brake lines</li> <li>• tighten brake mounting bolts</li> <li>• replace brake pads</li> <li>• replace master cylinder</li> </ul>
Brake fluid is leaking	<ul style="list-style-type: none"> <li>• replace master cylinder</li> <li>• repair brake lines</li> </ul>

### Brake Lines

You must bleed the hydraulic brake lines whenever you disconnect or replace any part of the hydraulic system, or when the fluid level is allowed to get below half full in the master cylinder. Bleed the brake lines using one of the following methods:

- ◆ Manually
- ◆ Using a brake bleeder

**Note:** *Manually bleeding the brake lines requires two people - one to press on the brake pedal, the other to open and close the bleeder valves.*

### Manually Bleeding Brake Lines

To bleed the brakes manually, perform the following:

- 1** Fill master cylinder to the top with DOT #5 brake fluid.

### Caution!

Be sure you use only DOT #5 brake fluid.

- 2** Have someone apply brake pedal pressure to force the fluid and air out of the lines.
- 3** Loosen the bleeder valve on the rear left wheel.

**Note:** *Be sure your assistant pushes the brake pedal all the way down and hold it down until you close the bleeder valve. Releasing the brake pedal before you close the bleeder valve will pull air back into the system.*

- 4** Close the bleeder valve.
- 5** Release brake pedal pressure.



- 6** Repeat steps 2 to 5 until no air pockets or bubbles are seen in the stream of brake fluid from the bleeder valve.

**Note:** *Make sure to maintain fluid level in master cylinder above half full during entire procedure.*

- 7** Repeat steps 2 to 6 for the rear right wheel, the front left wheel, and the front right wheel, in that order.
- 8** Add fluid to the master cylinder until the fluid is  $\frac{1}{2}$ " from the top, then replace the master cylinder cover.

### Using a Brake Bleeder

To bleed the brakes using a bleeder, perform the following:

- 1** Fill master cylinder to the top with DOT #5 brake fluid.

### Caution

Be sure you use only DOT #5 brake fluid.

- 2** Attach the brake bleeder to the master cylinder.
- 3** Loosen the bleeder valve on the rear left wheel cylinder until no air pockets or bubbles appear and the stream of brake fluid becomes clear. Close the bleeder valve.
- 4** Repeat the previous step for the rear right wheel, the front left wheel and the front right wheel, in that order.
- 5** Remove brake bleeder.
- 6** Add fluid to master cylinder until the fluid is  $\frac{1}{2}$ " from the top, then replace the master cylinder cover.

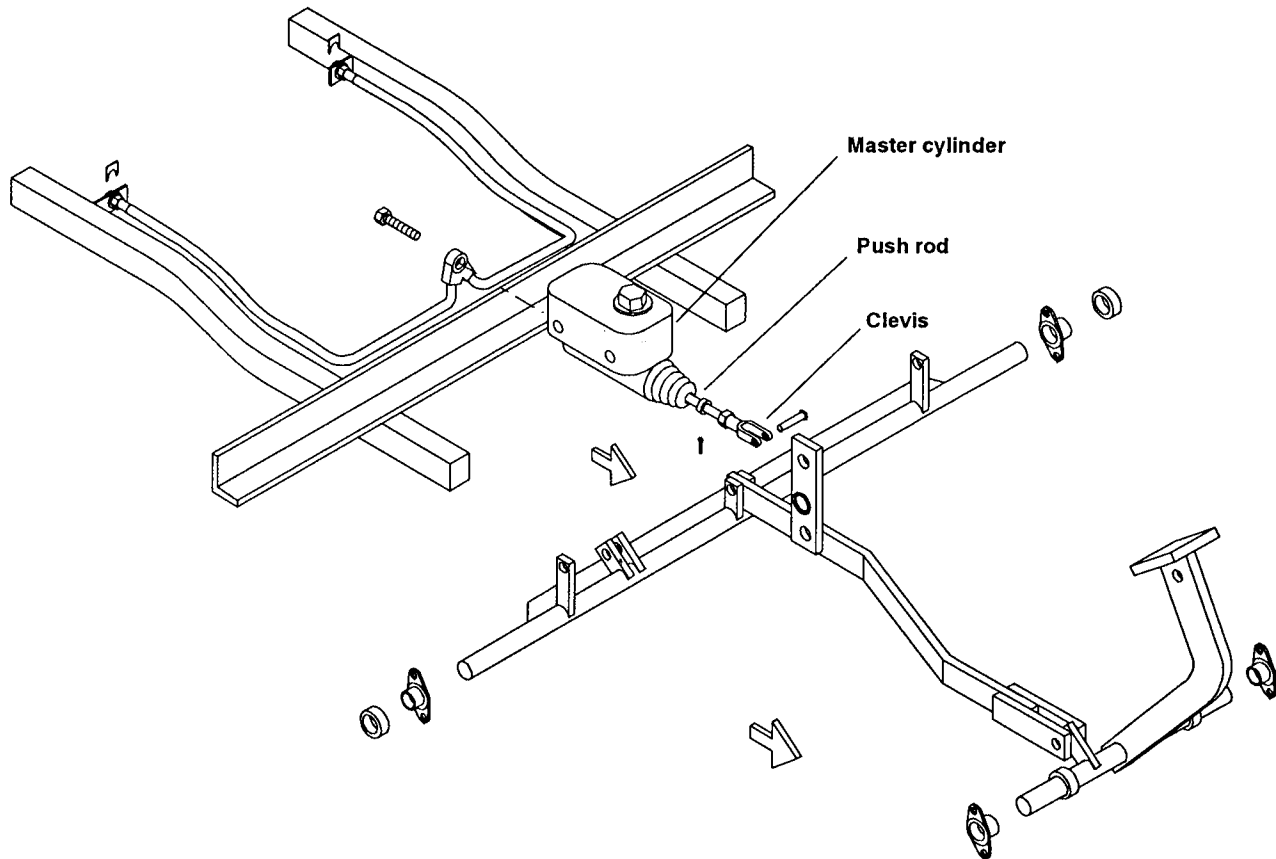

**Figure 3** - Hydraulic brake linkage

## Brake Pedal Linkage (Hydraulic)

To adjust the brake pedal linkage, perform the following (see Figure 3).

- 1** Loosen the jam nut on the clevis.
- Tip: The brake pedal clevis is located under the front seats, between the batteries.*
- 2** Turn the push rod counterclockwise until it contacts the head of the piston on the master cylinder.
  - 3** Shorten the push rod by turning clockwise 1 turn until the push rod just clears the head of the piston. The pushrod should be just loose.
  - 4** Tighten the jam nut to the clevis.

## Parking Brake Linkage (Hydraulic)

To adjust the parking brake linkage, perform the following (see Figure 4).

- 1** Raise and support vehicle.

### **WARNING!**

**Always use jack stands of adequate capacity when supporting the vehicle. Perform this procedure only on a flat, level surface.**

- 2** Remove cotter pin and clevis pin from parking brake linkage at parking brake lever.
- 3** Loosen jam nut and adjust linkage length to 13¼" as shown in Figure 4. Tighten jam nut.

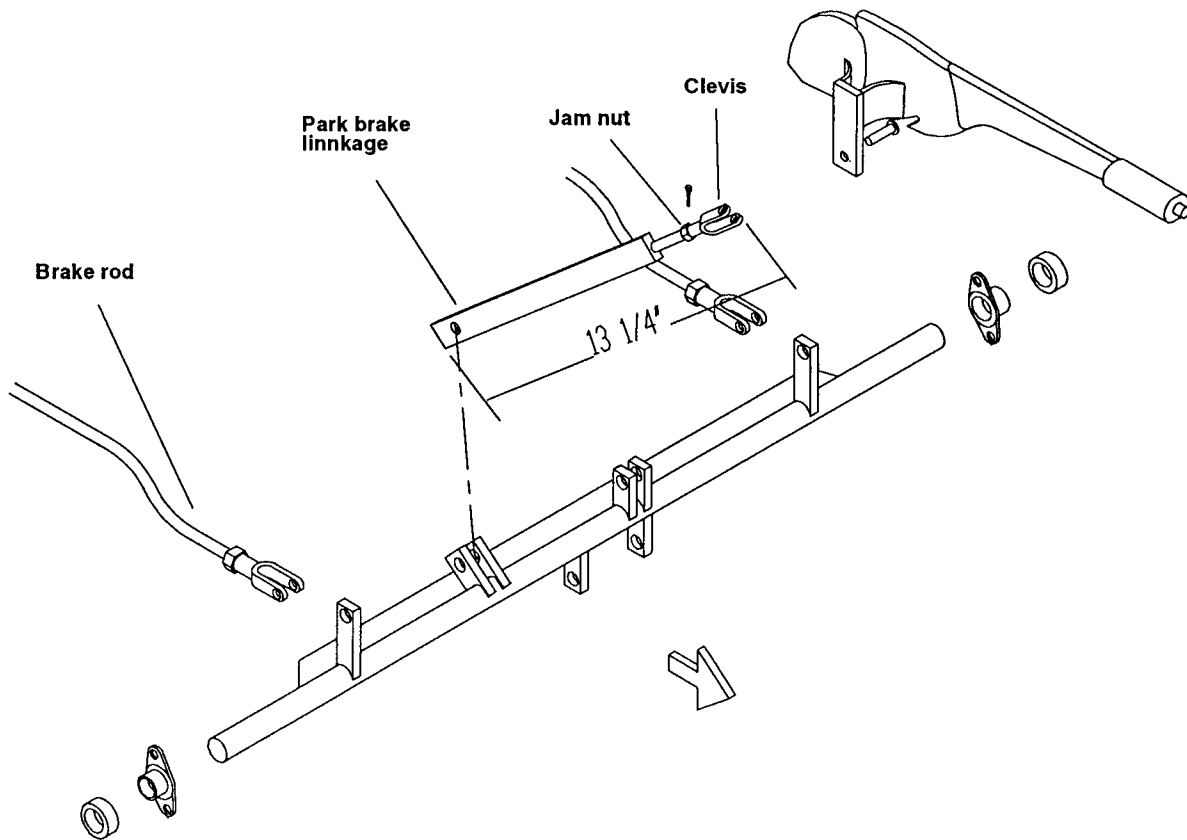

**Figure 4** - Parking brake linkage, hydraulic

- 4** Reconnect parking brake linkage to lever with clevis pin and new cotter pin.
- 5** Loosen jam nuts on brake rods.
- 6** Adjust brake rods as tight as possible without any detectable brake drag.
- 7** Check that the parking brake lever locks in the second to fifth position.
- 8** Tighten brake rod jam nut.

## Master Cylinder

To repair or replace the master cylinder, perform the following (see Figure 5):

- 1** Remove cotter pin, clevis pin and push rod from master cylinder.
- 2** Disconnect hydraulic line at the master cylinder.
- 3** Remove two holding bolts and master cylinder from chassis.
- 4** Clean outside of master cylinder with brake fluid and wipe dry.
- 5** Remove rubber boot and locking ring.

**Note:** Make sure that the piston parts do not pop out when removing the locking ring. The piston parts are under spring pressure.

- 6** Remove piston and cap.
- 7** Remove any scoring or roughness from inside the cylinder wall with a fine hone. Thoroughly clean cylinder.
- 8** Coat the new piston and cap with a small amount of clean brake fluid.
- 9** Install new piston and cap.

**Note:** Keep all parts free from dirt when installing.

- 10** Replace locking ring and rubber boot.
- 11** Replace master cylinder in chassis and reconnect hydraulic line.
- 12** Replace cotter pin, clevis pin and push rod.
- 13** Loosen the jam nut, turn the push rod counterclockwise until it contacts the head of the piston on the master cylinder.
- 14** Shorten the push rod by turning clockwise 1 turn until the push rod just clears the head of the piston. Tighten jam nut.
- 15** Fill master cylinder with DOT #5 fluid. Bleed brake system as described in "Brake Lines," this section.

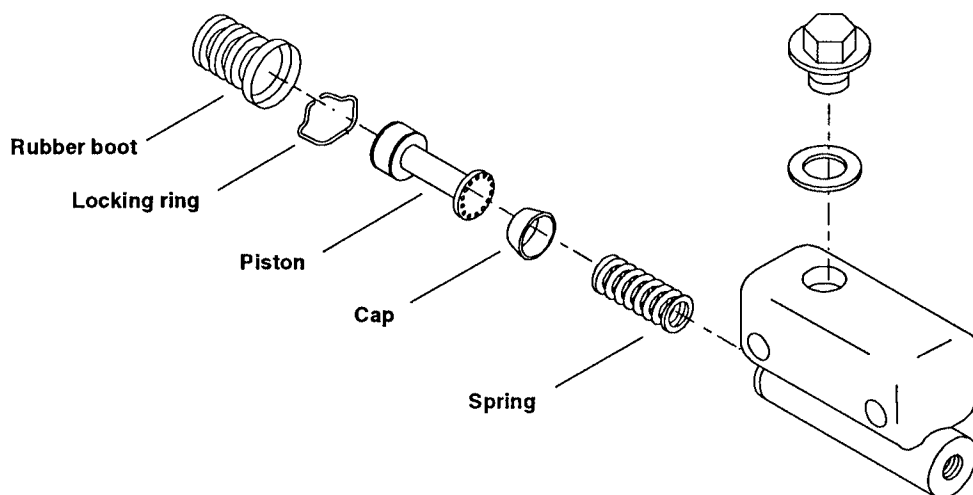

Figure 5 - Master cylinder

## **Rear Brakes (hydraulic)**

---

Servicing the rear brake assembly consists of:

- ◆ replacing brake pads
- ◆ Replacing the brake assembly

### **WARNING!**

---

If the brake cylinder is worn or cracked, or if the piston extends out through the o-ring, you must replace the entire brake assembly.

---

## **Replacing Hydraulic Brake Assembly**

---

- 1** Raise the vehicle and support it.

### **WARNING!**

---

**Always use jack stands of adequate capacity when supporting the vehicle. Perform this procedure only on a flat, level surface.**

---

- 2** Disconnect brake hose at the caliper.
- 3** Remove clevis pin.
- 4** Bend locking plates away and remove the four mounting bolts from the axle housing end flange.

### **WARNING!**

---

**The mounting bolts and the locking plates must be replaced when installing a new brake assembly.**

---

- 5** Lift the brake assembly off of the axle.
- 6** Remove the plate from the parking brake lever. Inspect the plate for excessive wear. Replace if necessary.
- 7** Install lever plate on the new brake assembly.
- 8** Slide the new brake assembly onto the disk.
- 9** Install new mounting bolts and locking plates.
- 10** Torque bolts to 20 ft-lb.
- 11** Bend locking plate tabs against bolt heads.

- 12** Attach brake hose and linkage.
- 13** Adjust linkage as described in "Brake Pedal Linkage (Hydraulic)," this section.
- 14** Bleed brakes as described in "Brake Lines," this section.
- 15** Test drive the vehicle to ensure that the brakes work correctly.

## **Replacing Brake Pads (Hydraulic)**

---

To replace the rear hydraulic brake pads, do the following:

- 1** Raise the vehicle and support it.

### **WARNING!**

---

**Always use jack stands of adequate capacity when supporting the vehicle. Perform this procedure only on a flat, level surface.**

---

- 2** Push pistons back into caliper.
- 3** Remove brake body bolts and spacers. Remove the brake pads and secondary plate.
- 4** Inspect spacers for cracking or flaring of the ends. Replace if defective.
- 5** Replace old brake pads with new brake pads.
- 6** Re-install secondary plate spacers and brake body bolts.
- 7** Using new nuts, tighten brake body bolts to 12 foot pounds of torque.
- 8** Turn disc by hand to be sure there is running clearance.
- 9** Lower vehicle and test drive for proper braking.

## FRONT AXLE

The front axle is designed for rugged, dependable service when properly maintained and lubricated (see Lubrication Chart in Section 3).

The steering worm gear box and steering arm are similar to those used in automobiles and require minimum maintenance .

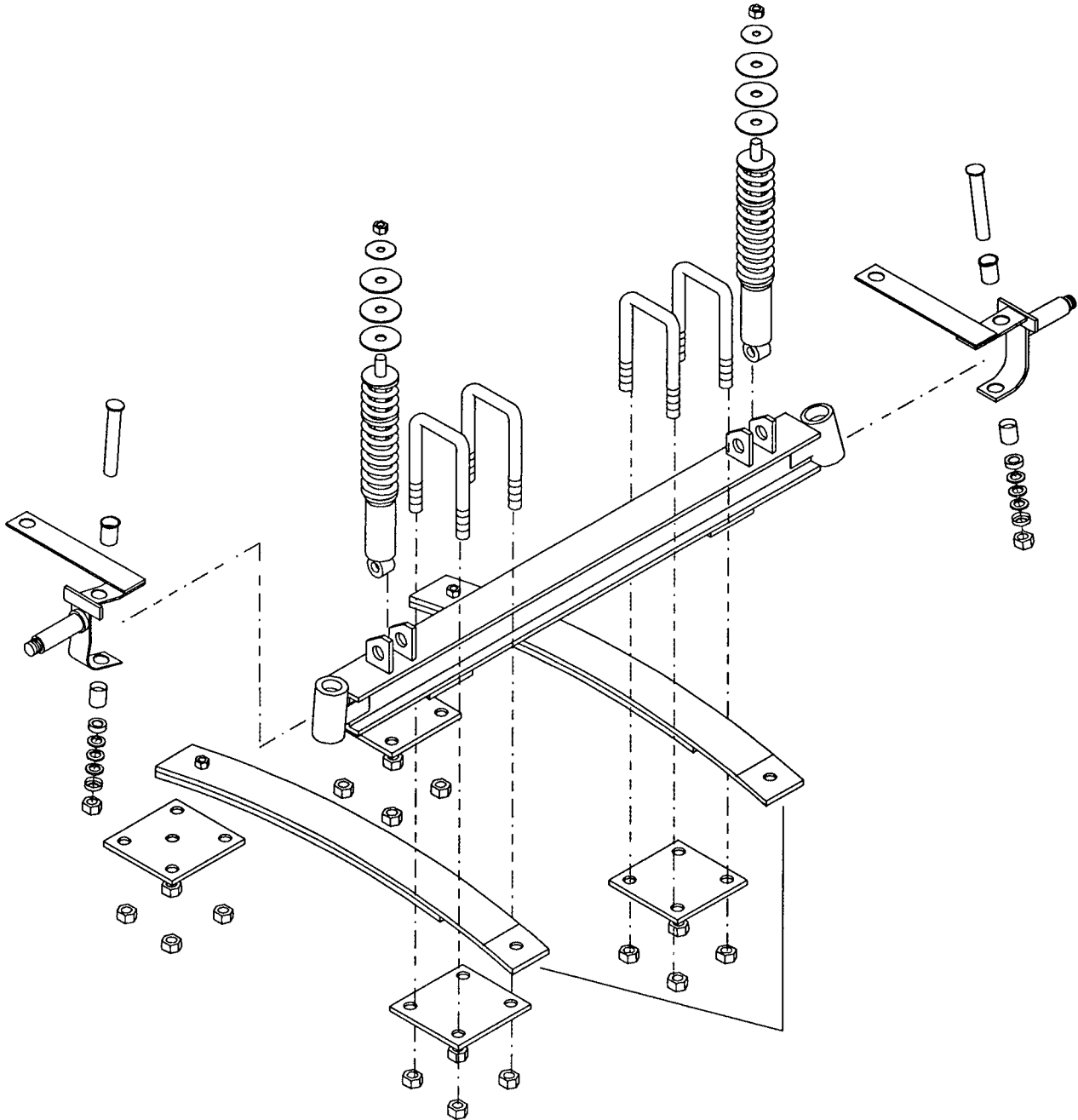

**Figure 6 - Front axle**

## Adjusting Bearings

To clean and adjust the front axle bearings, perform the following (see Figure 7).

- 1** Raise the vehicle and support it.

### **WARNING!**

**Always use jack stands of adequate capacity when supporting the vehicle. Perform this procedure only on a flat, level surface.**

- 2** Remove wheel.
- 3** Remove dust cap and cotter pin.
- 4** Unscrew spindle nut.
- 5** Remove outer washer and bearing.
- 6** Remove hub assembly from spindle.
- 7** Remove the grease seal and inner bearing.

- 8** Clean roller bearings, spindle and wheel hub with a rag. Do not wash bearing in solvent. Replace any worn or damaged parts.
- 10** Properly pack wheel bearing grease into roller bearings.
- 11** Reassemble inner bearing and grease seal into the wheel hub.
- 12** Mount hub assembly onto spindle.
- 13** Install outer bearing washer and nut.
- 14** Tighten spindle nut until you barely feel the roller bearing drag as you rotate the hub by hand, then back off the spindle nut about 1/4 turn.

**Note:** *The hub should now turn freely, but with no detectable bearing end-play.*

- 15** Install cotter pin, dust cap, and wheel.

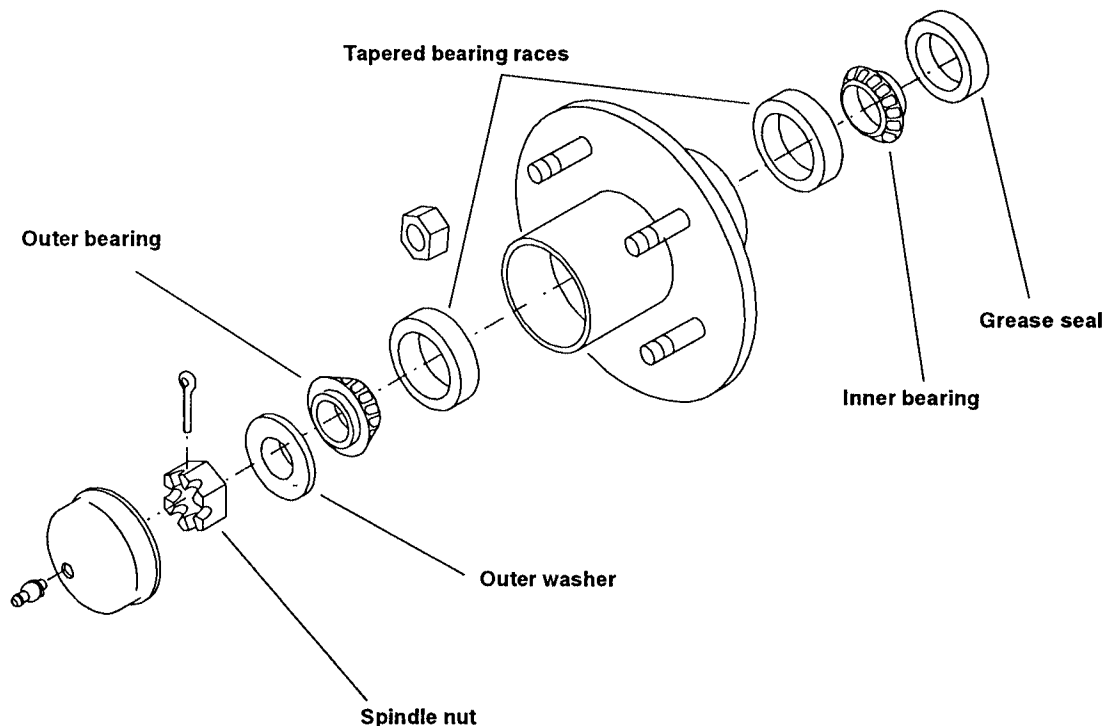

**Figure 7 - Front wheel hub assembly**

## Aligning the Front End

To align the front end for toe-in, perform the following:

**Note:** *The caster and camber are set at the factory and do not require adjustment.*

- 1** Raise the front end of the vehicle and support it.

### **WARNING!**

**Always use jack stands of adequate capacity when supporting the vehicle. Perform this procedure only on a flat, level surface.**

- 2** Mark the center of each front tire.

**Tip:** *Hold a white chalk or other marker against the tire tread at its center while rotating the tire.*

- 3** Lower front end.
- 4** Position front wheels straight ahead.
- 5** Measure the distance between the marks on the rear of the front tires.

- 6** Measure the distance between marks on the front of the front tires. If the rear measurement is not between 0 and  $\frac{1}{8}$ " greater than the front measurement, continue with the remaining steps.

- 7** Loosen the jam nuts on the tie-rods until the tie rod sleeves can be turned.

- 8** Turn the tie-rod sleeves until the difference in the distances between the front and rear marks on the front tires is between  $+\frac{1}{8}$ " and 0 (the front measurement less than the rear).

- 9** Tighten each tie-rod jam nut.

**Note:** *Be careful not to change the position of the tie rod while tightening jam nuts.*

**Note:** *The tie rods should be near equal in length.*

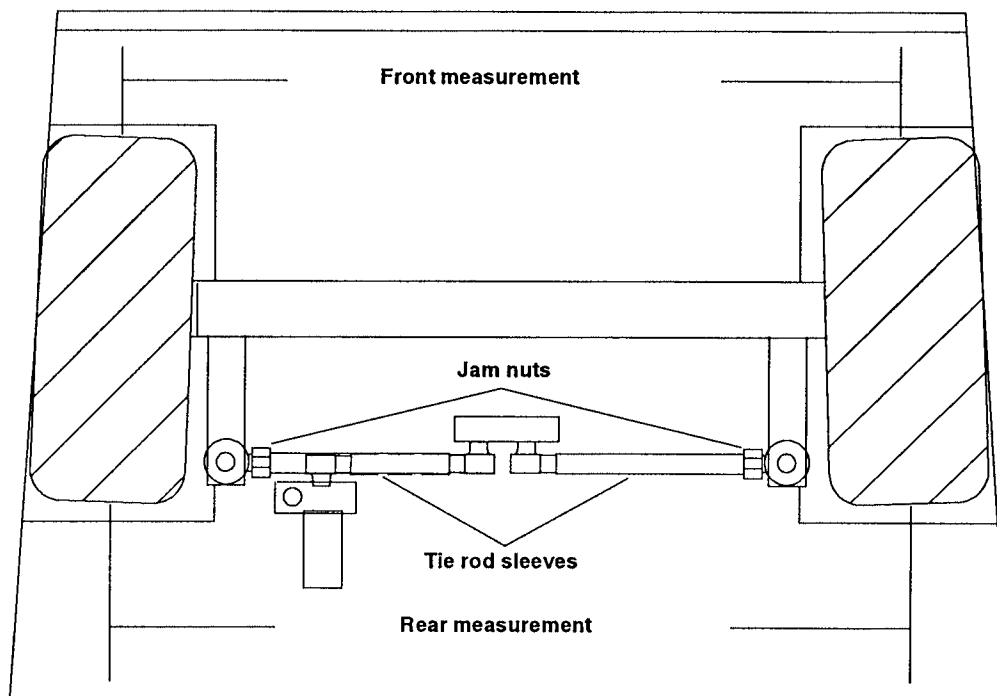

**Figure 8 - Aligning the front end**

## Repairing King Pins and Bushings

To repair or replace king pins and bushings, perform the following (see Figure 9):

- 1** Remove wheel.
- 2** Disconnect rod ends at the knuckle weldments.
- 3** Remove the king pin from knuckle weldment.

**Tip:** Use a soft rod (bronze or aluminum) to drive the king pin up through the knuckle if necessary.

- 4** Remove knuckle and pack bearing from axle sleeve.
- 5** Press bushings from axle sleeve.

- 6** Clean knuckle, king pin, axle sleeve and pack bearing with solvent or degreaser.
- 7** Press new bushings into sleeve using a bushing press.

**Note:** The upper bushing is a flange bushing and should be seated on the axle flange.

**Tip:** If you do not have a bushing press, contact your Taylor-Dunn dealer or any automotive supply house or repair shop for this service.

- 8** Broach or ream the new bushings until the inside diameter is between 0.878" and 0.880".

**Note:** Be sure that the bushings are in line with each other. The bottom bushing should be flush with the inside surface. The top bushing should be seated against the axle flange on the end tube.

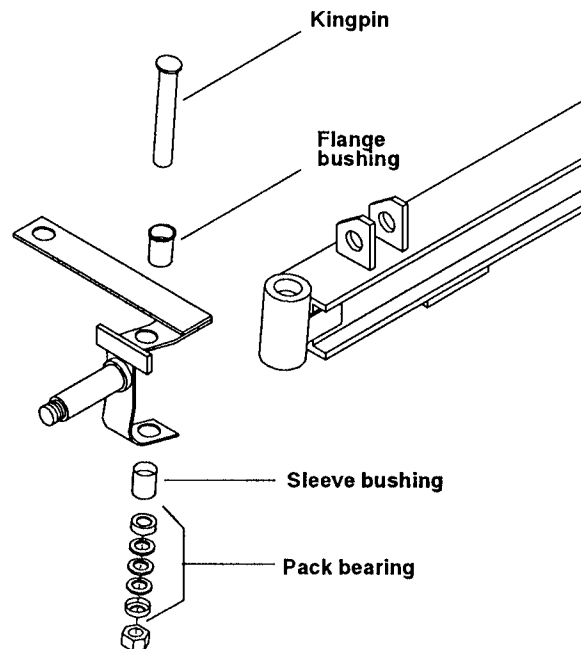

**Figure 9** - Front axle kingpin assembly



- 9** Lubricate the pack bearing with lithium grease.
- 10** Install knuckle weldments and pack bearing onto axle weldment.
- 11** Install king pin into knuckle weldment.
- 12** Tighten king pin locknut until it touches the bottom of the knuckle weldment. There will be some up/down movement of the knuckle.
- 13** Lubricate bushings and king pin with grease using grease fittings.
- 14** Install wheel.
- 15** Align the front end as described in "Aligning the Front End," this section.

**Note:** Always use new locknuts when repairing king pins and bushings.

**Note:** When tightening locknut on the king pin make sure that the knuckle weldment rotates freely.

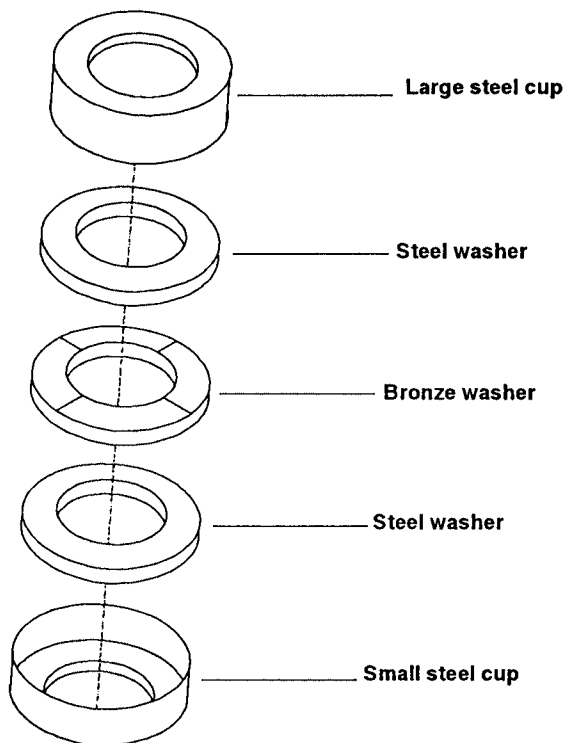

**Figure 10** - Kingpin bearing detail

## Replacing Rod Ends

To replace a rod end, perform the following (see Figure 11).

- 1** Raise the vehicle and support it.

### **WARNING!**

**Always use jack stands of adequate capacity when supporting the vehicle. Perform this procedure only on a flat, level surface.**

- 2** Remove wheel.
- 3** Remove rod end nut from the knuckle weldment.
- 4** Disconnect the rod end at the knuckle weldment.
- 5** Measure position of the rod end.

**Tip:** *Count the number of threads exposed on the rod end.*

- 6** Loosen rod end jam nuts.
- 7** Unscrew the rod end from tie rod.

**Note** *One end of the ball joint sleeve uses a right-hand thread; the other end uses a left-hand thread. Note which is which when you remove them so you can reinstall them correctly.*

- 8** Install new rod end in same position as the one which was removed.
- 9** Install rod end into knuckle weldment.
- 10** Replace jam nut.
- 11** Tighten rod end into the knuckle weldment.
- 12** Make sure all rod ends are tight and secure.
- 13** Make the necessary adjustments to center the steering wheel, then align the front end.

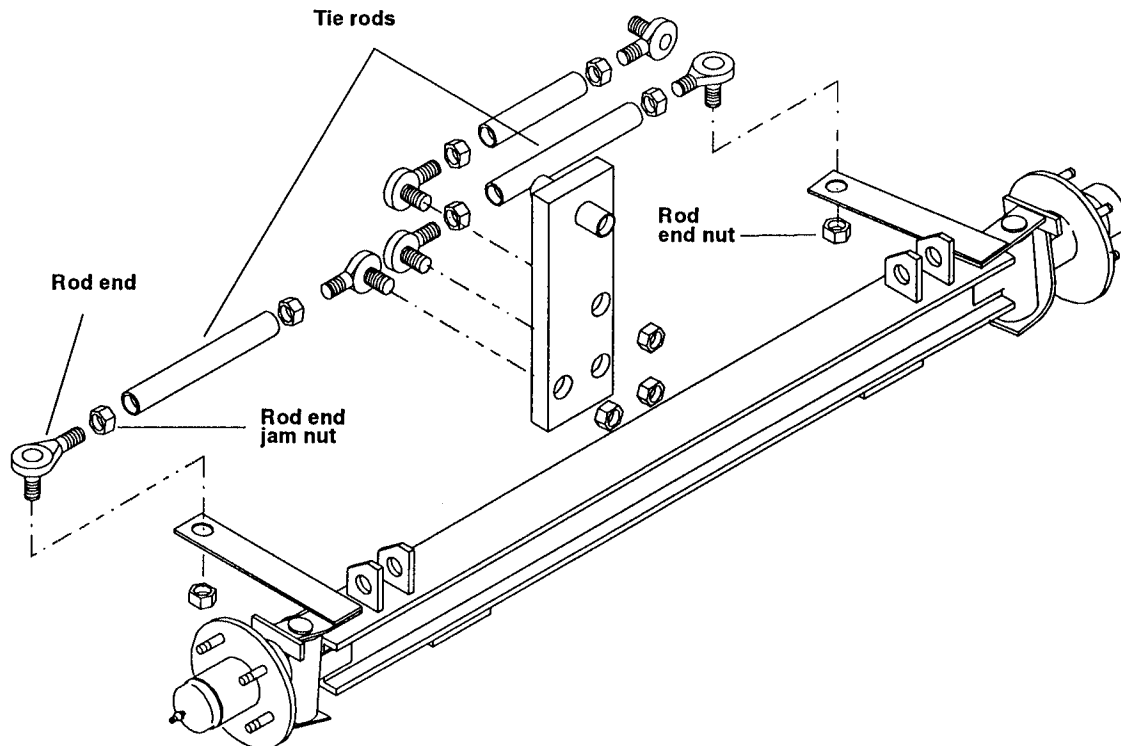

**Figure 11 - Front axle and steering linkage**

## Replacing the Steering Assembly

To replace the steering assembly, perform the following (see Figure 12).

- 1** Pry steering wheel cap up to expose the nut. Remove nut.
  - 2** Remove steering wheel.
  - 3** Disconnect drag link from the steering arm.
- Tip:** Use wheel puller.
- 4** Remove mounting bolts from the bottom of the steering assembly.
  - 5** Drop steering column out of bottom.
  - 6** Install new steering column shaft and worm assembly using the mounting bolts removed earlier.

- 7** Align front wheels straight ahead.
  - 8** Install steering wheel (but do not tighten yet).
  - 9** Center the steering column shaft and worm assembly.
- Tip:** Count number of turns lock to lock then turn wheel back half that number of turns.
- 10** Install drag link.
  - 11** With wheels straight ahead, remove and replace steering wheel so that it is centered.
  - 12** Tighten the locknut.
  - 13** Replace steering wheel cap.
  - 14** Grease steering gear.
  - 15** Check for smooth steering.

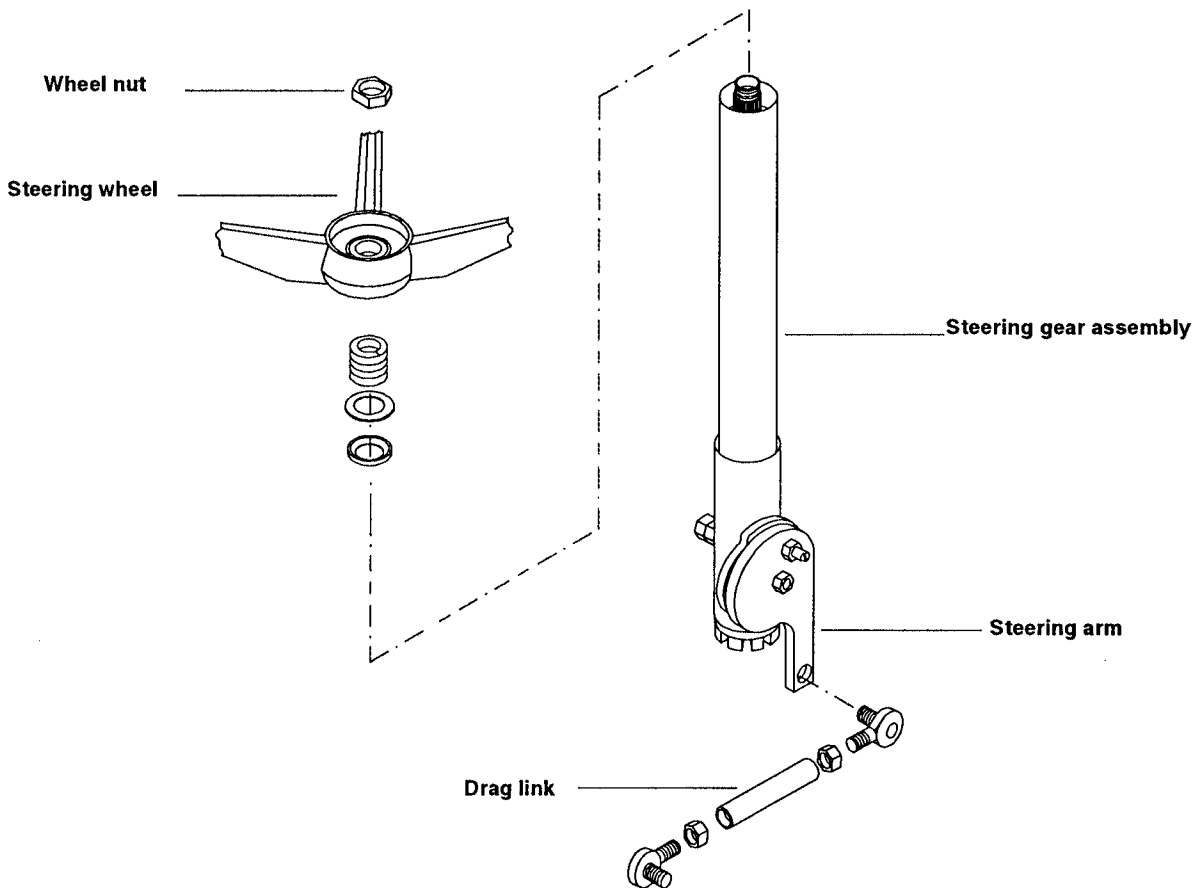

Figure 12 - Steering assembly

## Adjusting Steering Wheel Play

To adjust the steering wheel play, perform the following:

- 1** Raise the vehicle and support it.

### **WARNING!**

**Always use jack stands of adequate capacity when supporting the vehicle. Perform this procedure only on a flat, level surface.**

- 2** Center the steering wheel.
- 3** Disconnect the drag link
- 4** Loosen the lever stud jam nut on the steering lever, unscrew the lever stud until it stops.
- 5** Remove cotter pin from adjusting plug.
- 6** Loosen adjusting plug on steering gear housing.
- 7** Hand tighten adjusting plug.
- 8** Wiggle steering wheel and retighten, by hand, the adjusting plug.

- 9** Tighten adjusting plug two more notches and replace cotter pin with new one.
- 10** Loosen the two jam nuts holding the steering lever to the steering housing.
- 11** Tighten two jam nuts on the steering lever to remove all noticeable up and down play in the steering lever.

**Note:** *Be sure not to bend the steering lever when tightening the jam nuts.*

- 12** Tighten lever stud until steering wheel free play is  $1\frac{1}{4}$ " or less at the rim of the steering wheel.

**Note:** *Make sure that the  $1\frac{1}{4}$ " free play is with the steering wheel centered and that no tight spots exist over the entire steering travel.*

- 13** Tighten lever stud jam nut.
- 14** Adjust steering drag link so that the front wheels are straight when the steering wheel is centered.

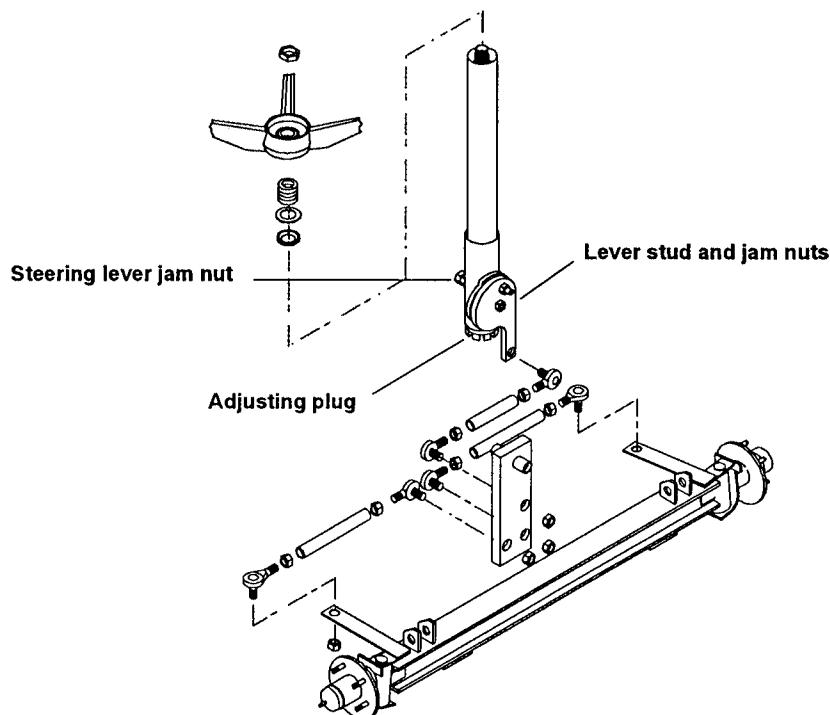

**Figure 13 - Front axle and steering**

## REAR AXLE ASSEMBLY

The rear axle assembly consists of the following:

- ◆ Drive chain or belts
- ◆ Differential
- ◆ Rear axle

---

### Drive Belts and Chains

---

#### Adjusting Drive Belt Tension

**Note:** *New belts will seat-in rapidly during the first hours of operation. Check the belt tensioning frequently during the first several weeks of operation with new belts.*

#### **CAUTION!**

---

Disconnect both power leads to the battery before attempting this procedure.

---

- 1** Loosen motor mount nuts slightly.
- 2** Loosen motor adjusting bolt lock nut and then turn adjusting bolt to achieve proper belt tension. The proper tension is achieved when the belts can be deflected 1/4 to 3/8" at their midpoint.
- 3** Rotate drive pulley several revolutions and check the belt tension. Adjust as necessary.
- 4** Repeat Step 3 until further adjustment is not necessary.
- 5** Tighten adjusting bolt lock nut while preventing bolt from turning.
- 6** Check pulley alignment. Tap motor bracket to achieve proper alignment.
- 7** Tighten motor mount nuts.



### Replacing Drive Belts

To replace the drive belts, perform the following:

**WARNING!**

**Disconnect both power leads to the battery before attempting this procedure.**

- 1** Loosen motor clamp nuts slightly.
- 2** Loosen motor adjusting bolt lock nut.
- 3** Turn adjusting bolt sufficiently to allow removal of the belts.
- 4** Install all new belts .

**Note:** *Replacement of less than all of the belts will prevent attaining proper tension on all belts and cause premature belt failure or excessive wear.*

- 5** Adjust belt tension (see "Adjusting Drive Belt Tension," this section).

### Adjusting Optional Drive Chain

To adjust the drive chain tension, perform the following:

**WARNING!**

**Disconnect both power leads to the battery before attempting this procedure.**

- 1** Tighten the three motor mounting nuts and then back each off exactly one full turn.
- 2** Loosen the adjusting bolt lock nut.
- 3** Turn the adjusting screw clockwise to a torque of 20 ft lbs. Back adjusting bolt off exactly 2½ turns.
- 4** Ensure that the motor is all the way back against the adjusting bolt.
- 5** Tighten adjusting bolt lock nut while preventing adjusting bolt from turning.
- 6** Tighten the three motor mounting nuts.

### Removing the Motor (Power Traction)

To remove the motor without removing the chain case cover, perform the following:

**WARNING!**

**Disconnect both power leads to the battery before attempting this procedure.**

- 1** If not already done, disconnect both battery power leads.
- 2** Loosen the three motor mount nuts and the adjusting bolt lock nut.
- 3** Back-off the adjusting bolt sufficiently so as to allow the motor mounting plate to fully bottom.
- 4** Remove the three motor mounting nuts and washers.
- 5** Remove chain from the sprocket and remove the motor.

### Installing the motor (Power Traction)

To install the motor when the chain case has not been removed, perform the following:

1. If applicable, clean the motor and mounting plate mating surfaces. Install the motor on the mounting plate using appropriate flat head screws.
2. If applicable, install spacers, key, sprocket, washer and shaft nut to motor shaft. Tighten shaft nut to 75 ft. lbs.
3. Place O-ring in motor mounting plate opening.
4. Using a piece of wire, reach through the opening in the back of the chain case and lift the chain above opening. Secure chain in this position by attaching the wire to a suitable object.
5. Remove a motor brush inspection cover if the armature is not plainly visible through the vents.
6. Orient the motor so that the motor mounting plate clears the chain case backing studs.
7. Slip the motor sprocket into the chain case and under the chain. Position the motor onto the studs.
8. Remove the wire supporting the chain.
9. Move the vehicle slightly and observe the movement of the motor armature.
10. Install washers and nuts. Only finger tighten the nuts.
11. Move the vehicle slightly and observe the movement of the armature which indicates that the chain is still engaging the sprocket.
12. Adjust the drive chain.



---

*If chain is not properly positioned on the sprocket, severe damage can occur to Power Traction components.*

---

To determine motor brush condition on the 5BC8JB86110A motor, insert a 3/32 rod in to the brush inspection holes (there are two holes). The rod will go in approx. 5/8 inch with a new brush. If it goes in 1 inch or more the brushes need to be replaced. Check both holes.

To determine motor brush condition on other motors, Remove the brush inspection cover and check visually. If any one of the brushes are less than 3/8 inch long the brushes need to be replaced.

---

## Power Traction Assembly

---

### Disassembling the Power Traction Assembly

- 1** Drain oil from chain case
- 2** Remove bolts and nuts from the front of the chain case cover. Remove chain case cover.
- 3** Remove the three nuts and washers which fasten motor to motor mounting plate.
- 4** Disengage the chain from the motor sprocket. Remove motor.
- 5** Remove O-ring from motor mounting plate.
- 6** Remove chain, pinion sprocket, and spacers from pinion shaft. Note spacer location for reassembly.
- 7** If required due to further disassembly, remove chain case backing plate and gasket by removing five retaining bolts.

### Reassembling Power Traction Assembly

- 1** To reassemble, install the chain case backing plate and gasket (with sealer) to differential with five bolts previously removed. Tighten bolts to 50 ft lbs.
- 2** Install pinion sprocket and spacers.
- 3** Install chain on pinion sprocket.
- 4** Install O-ring in motor mounting plate and attach motor and motor mounting plate to chain case backing plate.
- 5** Engage chain onto motor sprocket and secure motor mounting plate to chain backing plate with the three nuts and washers previously removed.
- 6** Adjust the drive chain (see "Adjusting Optional Drive Chain," this section).
- 7** Install the chain case cover and gasket (replace if damaged) to chain case backing plate. Tighten cover retaining bolts and nuts.
- 8** Fill chain case with appropriate oil.
- 9** Connect battery and motor power leads.

---

## Rear Axle Bearings

---

### Removing Rear Axle Bearings

**WARNING!**

**Disconnect both power leads to the battery before attempting this procedure.**

- 1** Raise and support vehicle.

**WARNING!**

**Always use jack stands of adequate capacity when supporting the vehicle. Perform this procedure only on a flat, level surface.**

- 2** Remove wheel assembly.
- 3** Bend back locking tabs and remove four bolts hold disc brake mounting bracket to axle housing.
- 4** Disconnect mechanical linkage from brake caliper. Remove brake caliper.
- 5** Pull axle from housing.

**CAUTION!**

Use a puller that is specifically designed for this purpose. Do not force the axle out by pounding or prying, which can cause permanent damage.

- 6** Pull bearing retainer ring and bearing from axle.

### Installing Rear Axle Bearings

- 1** Press new bearing and retainer ring on to shaft.
- 2** Remove and replace oil seal and all other gaskets.
- 3** Install axle back into housing.
- 4** Install brake caliper. Reconnect brake linkage.





- 5 Install four brake mounting bracket bolts and nuts. Tighten to 35 ft lbs and bend up locking tabs.

### **WARNING!**

**Failure to properly bend up locking tabs could result in eventual loosening of brake caliper and failure of brake action.**

- 6 Reconnect brake linkage.
- 7 Reconnect power leads to battery.

## Differential

### Disassembling the Differential

To disassemble the differential assembly, perform the following:

**Note:** *This procedure assumes that the differential has already been removed from the vehicle and that the brakes, axles, and belt or chain drive have also been removed. Refer to appropriate sections of this chapter for the respective procedures.*

- 1 Remove nuts around the differential carrier housing. Remove differential carrier from axle housing.
- 2 Mark one differential bearing cup and bearing support to aid in proper re-assembly.
- 3 Remove adjusting nut locks.
- 4 Remove the two bolts securing each bearing support cap. Remove the bearing support caps.
- 5 Remove adjusting nuts, and bearing caps.
- 6 Remove differential case assembly from axle housing.
- 7 Pull the differential case bearing and remove ring gear as desired.
- 8 Remove bolts around the drive pinion retainer. Remove the drive pinion assembly.
- 9 Remove O-ring and shim from the drive pinion assembly.

- 10 Remove nut on end of drive pinion gear shaft.
- 11 Remove the drive pinion gear shaft assembly.
- 12 If the drive pinion bearings must be replaced due to wear or damage, pull bearings from shaft. Press out bearing cups from housings.

**Note:** *Do not remove pinion bearing races from pinion shaft retainer unless the bearings are being replaced. The location of these cups are used to machine the flange and pilot after they are installed in the bores. If you must replace the cups, use a 0.0015" feeler gauge between the new cup and the bottom of the bore to ensure proper positioning of the cup.*

### Assembling the Differential

- 1 Lubricate all parts liberally using axle lubricant.
- 2 Install front pinion bearing and race onto the pinion gear.
- 3 Install spacers and shim onto the pinion drive gear shaft.
- 4 Place the pinion shaft retainer onto the pinion gear and install the pinion bearing.
- 5 Place spacers onto spline of pinion gear.

**Note:** *If the drive pinion, bearings, etc. have been changed, shims between bearings may have to be changed to obtain proper bearing adjustment. Bearings are properly adjusted when the shaft turns freely, but the roller bearings themselves can not be slid on their races without rotating (i.e., no axial play).*

- 6 Install O-ring on pinion retainer.
- 7 Install drive pinion assembly into the carrier housing. If drive pinion and/or ring gear have been changed, refer to shim selection procedure later in this chapter. Otherwise install the original shim.

- 8** Install and alternately tighten each drive pinion retainer bolt by hand, then torque each bolt to 50 ft. lbs. Progressively tighten bolts in an alternating pattern to assure proper seating of assembly.
- 9** Press or tap the pinion drive gear into position.
- 10** Install pinion gear washer and nut and tighten to 100 ft. lbs. of torque.

**Note:** *The housing cover bolts will be removed later when you install the backplate assembly.*

- 11** Install new bearings as required on the differential case shafts.
- 12** Install ring gear if removed.

- 13** Install differential housing, bearing cups, adjusting nuts, and bearing supports into the differential carrier. Where applicable, install parts in their original locations.
- 14** Tighten the two bolts in each bearing support. Ensure that the bearing adjusting nuts can be still turned. If not, loosen bearing support bolts slightly.
- 15** Tighten the adjusting nut on the side away from the ring gear until the drive pinion and ring gear are tightly seated (the pinion shaft is difficult to turn). Ensure that nut on ring gear end is loosened sufficiently. Back off the adjusting nut on opposite end from ring gear  $\frac{1}{4}$  turn.

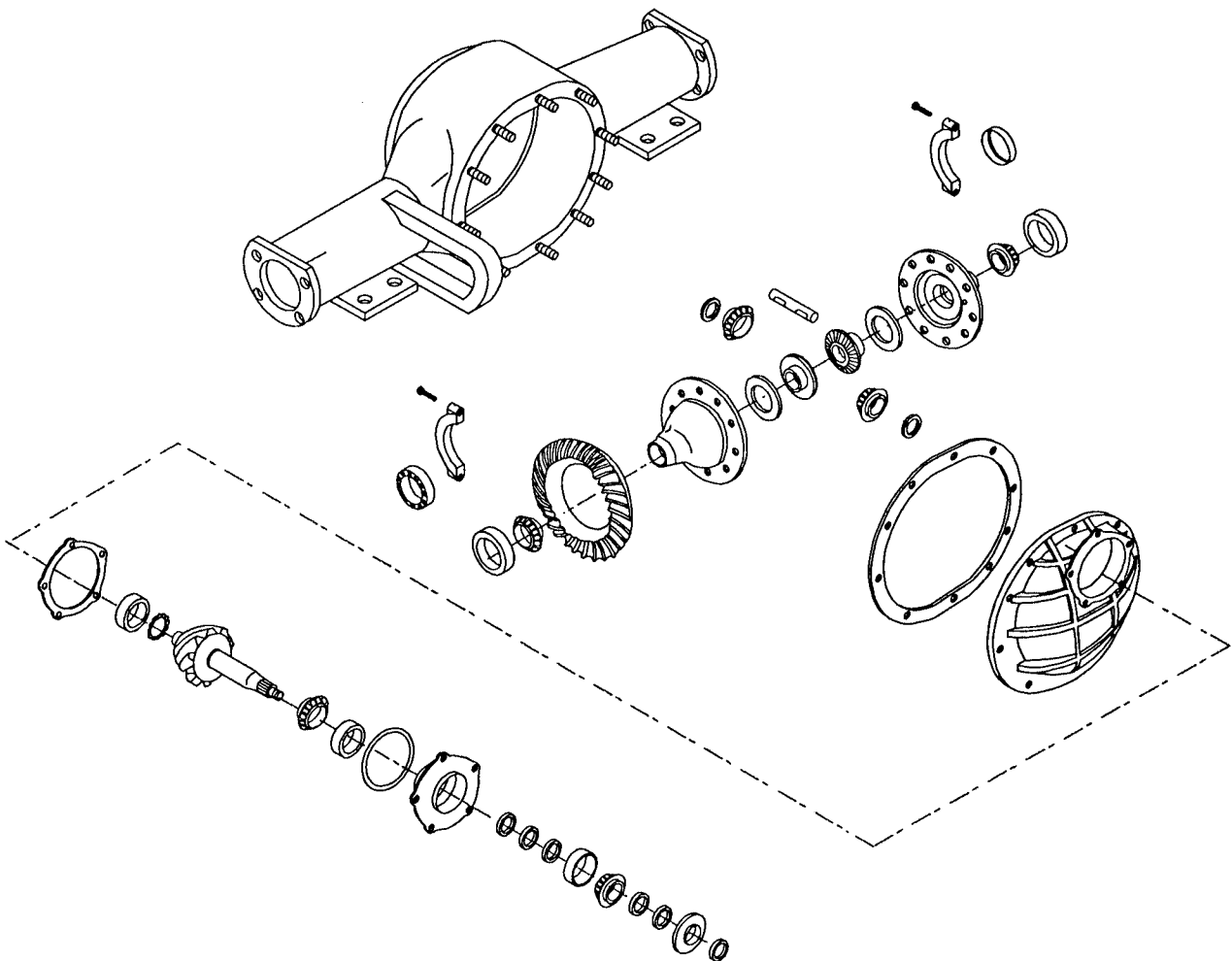

**Figure 14 - Differential**

- 16** Tighten adjusting nut on ring gear end until there is no detectable end play in the bearings and shafts rotate freely.
- 17** Tighten the two bolts on each bearing cap.

**Caution**

Do not allow any bearing play or looseness. This causes gear noise and leads to unnecessary wear on the gears.

- 18** Spin differential using impact wrench on pinion shaft nut or by other means. The assembly should not produce excessive noise. If there is excessive noise, try loosening the adjusting nut away from ring gear  $\frac{1}{8}$  turn and then retightening adjusting nut on ring gear end. Spin assembly again. If the unit is still noisy and the ring and pinion gears are in good condition, the drive pinion shim may need to be adjusted (see next page).
- 19** Install adjusting lock clips.
- 20** Install differential carrier into the axle housing with a new gasket (use gasket sealer).
- 21** Install differential housing bolts and tighten to 50 ft. lbs. of torque.

**Selecting Drive Pinion Shims**

Shims are available in 0.010" to 0.021" thickness in steps of 0.001" to correctly position the drive gear. A standard shim is 0.015" thick. Inserting a thicker shim between a pinion retainer and the carrier moves the pinion away from the drive gear.

**Note:** *Matched pinions and drive gears use the same number.*

**Note:** *A "+" or a "-" indicates whether to add or subtract the indicated amount from a standard shim. The following numbering system is used on pinions to indicate the amount you must add to or subtract from the standard shim:*

PINION NUMBERING SYSTEM	
If number is:	Adjust standard shim as follows:
0	standard shim (no adjustment)
+1	add 0.001"
+2	add 0.002"
+3	add 0.003"
+4	add 0.004"
+5	add 0.005"
-1	subtract 0.001"
-2	subtract 0.002"
-3	subtract 0.003"
-4	subtract 0.004"
-5	subtract 0.005"

# ELECTRICAL SYSTEM

The vehicle's electrical system consists of the following:

- ◆ Battery
- ◆ Battery Charger
- ◆ Electrical wiring
- ◆ Control Module
- ◆ Instrument panel

## **WARNING!**

**Disconnect the main battery leads and remove the ignition key before working on any part of the vehicle's electrical system.**

Figure 15 shows an overall view of the vehicle's electrical system. Figures 16 and 17 are detailed wiring diagrams.

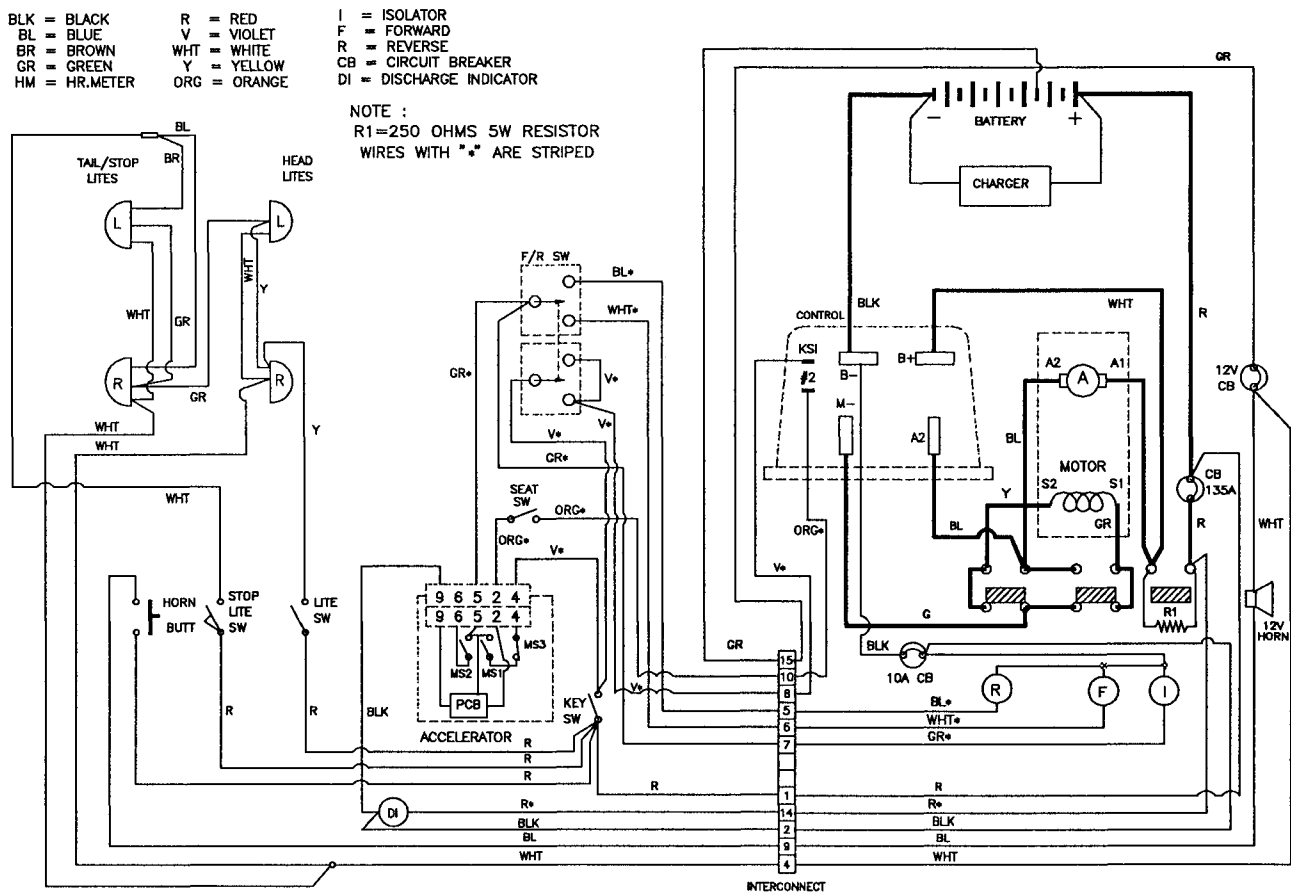

Figure 15 - Overall electrical system

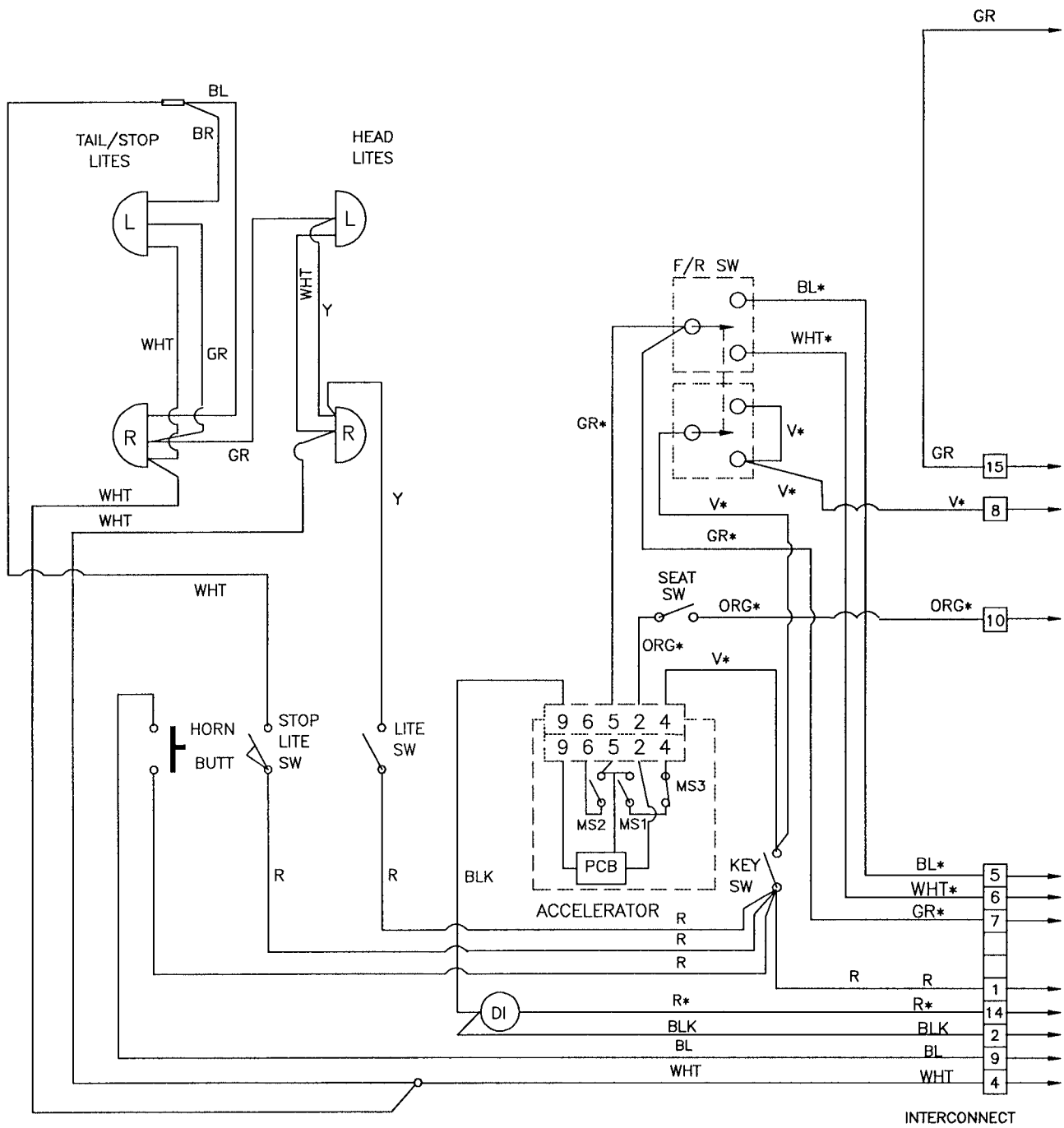

Figure 16 - Chassis wiring

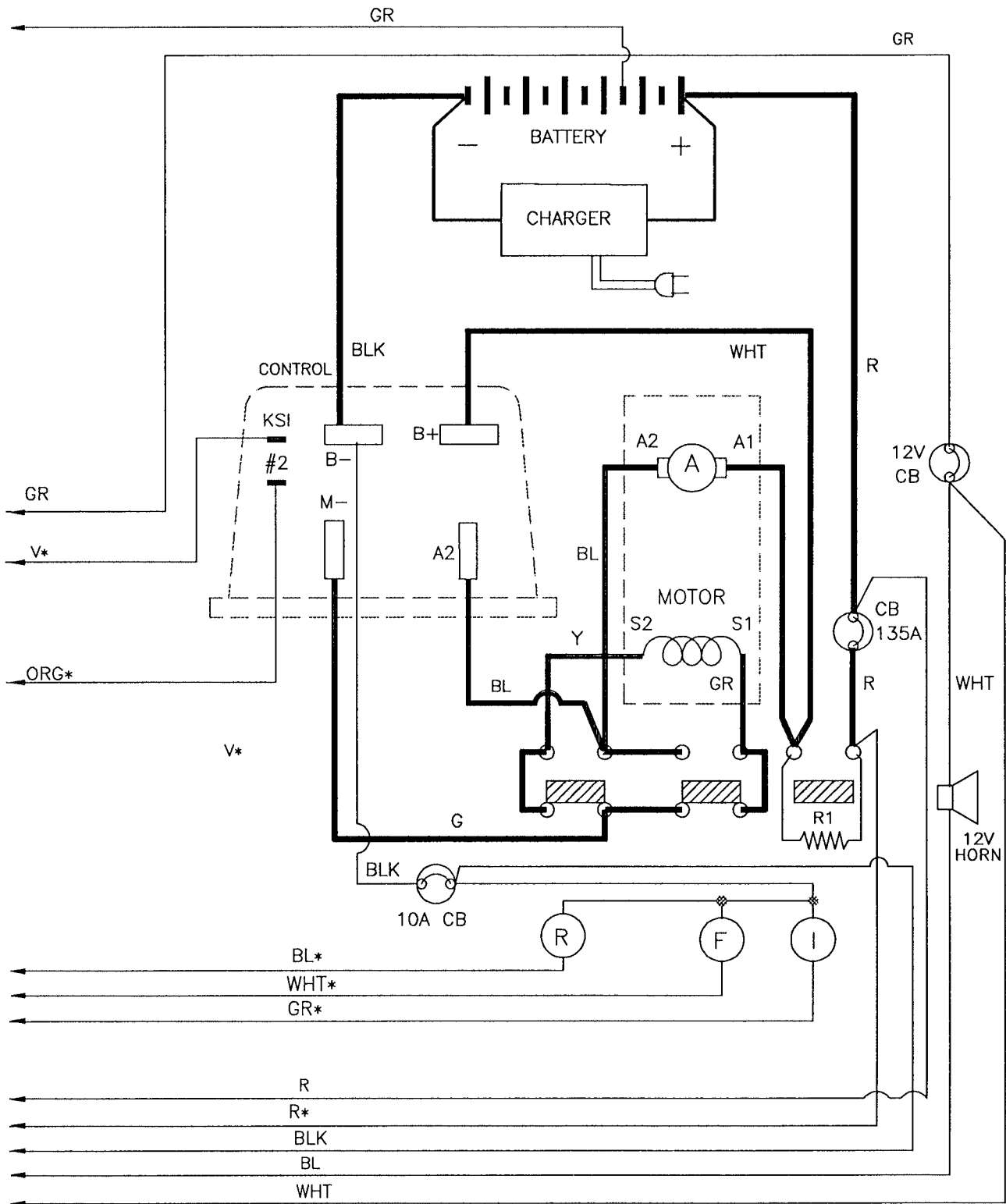

Figure 17 - Control module wiring

## **Batteries**

---

Batteries of the type supplied with the vehicle will provide many years of operation if properly cared for. The following suggestions should be adhered to in order to obtain the maximum life from the batteries.

- ◆ New batteries should be given a full charge prior to use.
  - ◆ All cells in the battery must be good. One or more defective cells will greatly reduce the operating capacity of the battery and can shorten the life of the remaining good cells. Check the voltage across each cell after charging to ensure that they are all good. Cells can also be checked using a hydrometer.
  - ◆ It is not a good idea to install a few new batteries in a string of old batteries.
  - ◆ Vehicles should be charged every day after use or when a low indication is seen on the charge indicator/voltmeter.
  - ◆ Batteries should not be left in a discharged state for extended periods of time.
- ◆ Batteries which are stored for extended periods of time should be charged every month.
  - ◆ Avoid running batteries down to the point where the vehicle will not operate properly.
  - ◆ Avoid storing and/or operating batteries at temperature extremes. Cold temperatures reduce capacity and high temperatures reduce battery life.
  - ◆ Maintain the electrolyte at the proper level. The fluid should be replaced with distilled water.
  - ◆ Water consumption increases with the age of the battery.
  - ◆ Keep batteries and electrical connections clean.

## Battery Chargers

### Caution

Observe the following precautions associated with batteries and chargers.

- ◆ Battery chargers supplied with vehicles are intended for use only on the specific type and capacity of battery in the specific vehicle. Use on other systems can damage the charger and/or batteries.
- ◆ Attempting to charge improperly wired batteries may blow fuses in the charger.
- ◆ When installing batteries, be sure to wire each battery correctly with respect to its polarity. Failing to do so can cause damage to the batteries, charger, or other vehicle components.

- ◆ The battery charger contains an AC capacitor which has a high voltage on it during normal operation. Ensure that this capacitor is fully discharged before attempting any service operations on the battery charger.

## Lestronic Battery Chargers

The Lestronic battery chargers are advanced, automatic chargers which ensure proper battery charging. The chargers incorporate an electronic timer and a ferro-resonant transformer, which regulates the output voltage and limits the current, to provide for precise battery charging.

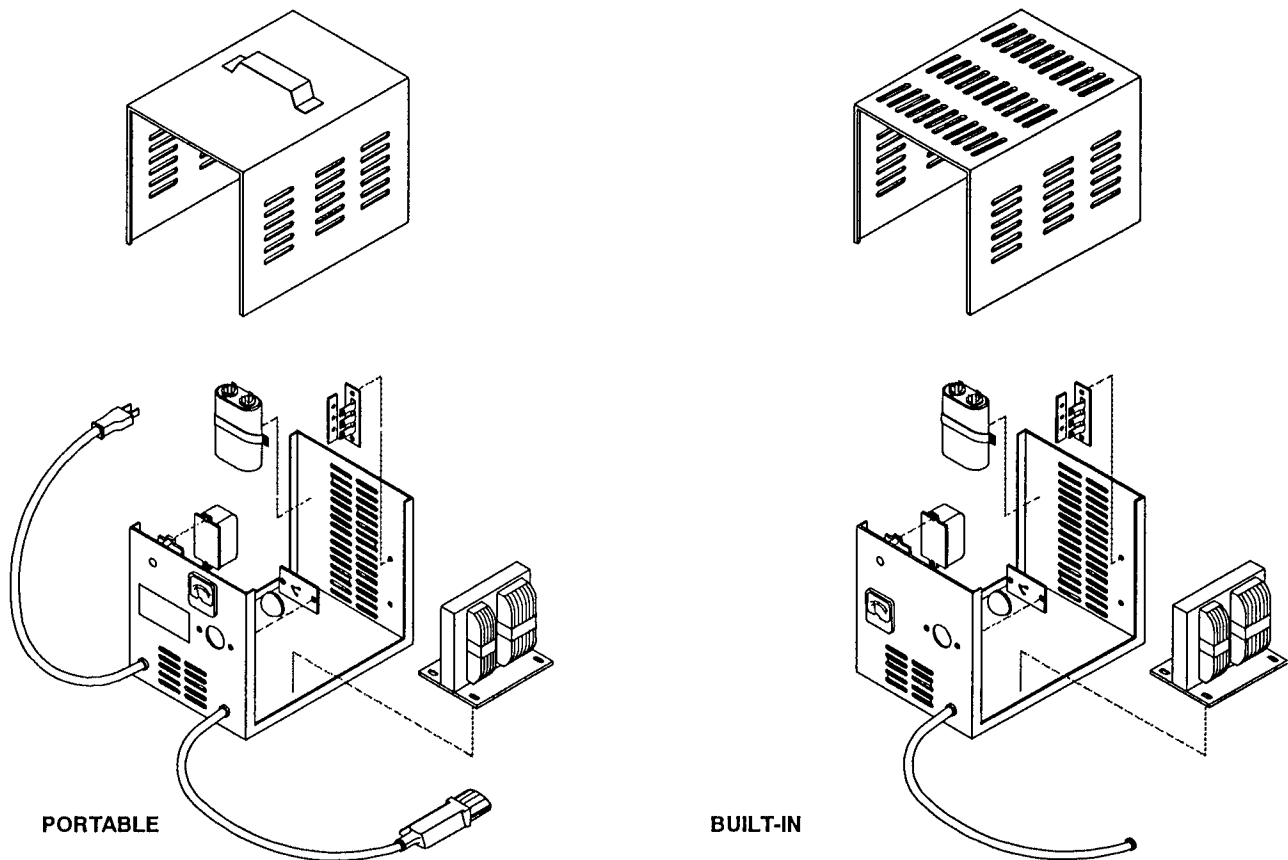

Figure 18 - Portable and Built-in battery chargers



The charger turns on automatically when it is connected to the battery and the AC input. The electronic timer within the charger monitors the rate of voltage change across the battery and turns charger off when the battery is fully charged. There is no danger of overcharging the battery.

### Installation

The AC line that the charger is plugged into should be properly protected and sized for 15 amps. Extension cords should only be used when absolutely necessary and should also be sized for a 15 amp load. The use of a long extension cord will extend the time required to fully charge the battery.

### Normal Operation

Under normal operation, the initial charge rate of a discharged battery will vary from 18 to 30 amps. As the charging progresses, the charging current will taper down to 3 to 7 amps. When the battery is fully charged, the battery charger will shut off.

---

## Charger Troubleshooting

---

The following information is designed to allow the troubleshooting and repair of the battery charger. It is assumed that all individuals who attempt to service the battery charger are competent to work on electrical equipment of this type.

### **Warning!**

**The battery charger contains a capacitor which operates at a high voltage. Ensure that the input power is removed from the battery charger and that this capacitor is fully discharged before attempting any service procedures.**

---

**Note:** *The following tests assume that the battery charger is connected to a partially discharged set of batteries which allow the charger to be tested.*

### No Transformer Hum

- 1** Check to see that the input power cord is securely plugged into a live AC outlet.
- 2** At the timer board assembly within the charger, short terminals #1 and #3. If the charger starts, replace the timer assembly.

### Transformer Hums but no Output

- 1** Inspect DC connections from charger to batteries.
- 2** Disconnect the battery charger from both the batteries and the AC line.
- 3** Using a continuity tester, check the DC fuse links. Replace any blown links.
- 4** Using a continuity tester or ohmmeter capable of testing a silicon diode, check continuity in both directions on each rectifier diode. The diodes should conduct in one direction and show an open circuit in the other. Replace the entire assembly if either diode is found to be faulty.
- 5** Check the continuity of all AC and DC wiring.
- 6** Short across the battery charger's AC capacitor to ensure that it is completely discharged. Disconnect one wire from the capacitor and check the capacitor with a continuity tester or ohmmeter. It should appear to be an open circuit. If not, replace the capacitor.
- 7** Check to see that the capacitor's top is flat and not domed up. If it appears not to be flat, replace the capacitor.
- 8** Check the transformer. Replace if it shows signs of having overheated.
- 9** Check the continuity through each transformer winding. They should all appear as a short circuit. If any appear to be open, replace the transformer.

**Charger Output is Low**

Perform the following tests:

- 1** Disconnect the battery charger from both the batteries and the AC line.
- 2** Check the diodes and fuse links as described above. Replace if found defective.

**Charger does not Turn Off**

Several possible causes are not associated with the charger and should be checked. They include that the batteries are old and will not charge properly and that the batteries being charged are much larger than the charger was designed to handle. If this is not the case, replace the timer board.

**AC Input Circuit Breaker Blows**

If the AC input service is properly sized and not loaded by other devices, then the input section of the charger is shorted. Replace the transformer and/or the timer.

# ELECTRICAL CONTROLS

The electrical controls consist of:

- ◆ Accelerator module
- ◆ Horn
- ◆ Solenoids
- ◆ Speed controller
- ◆ Breakers
- ◆ Wiring

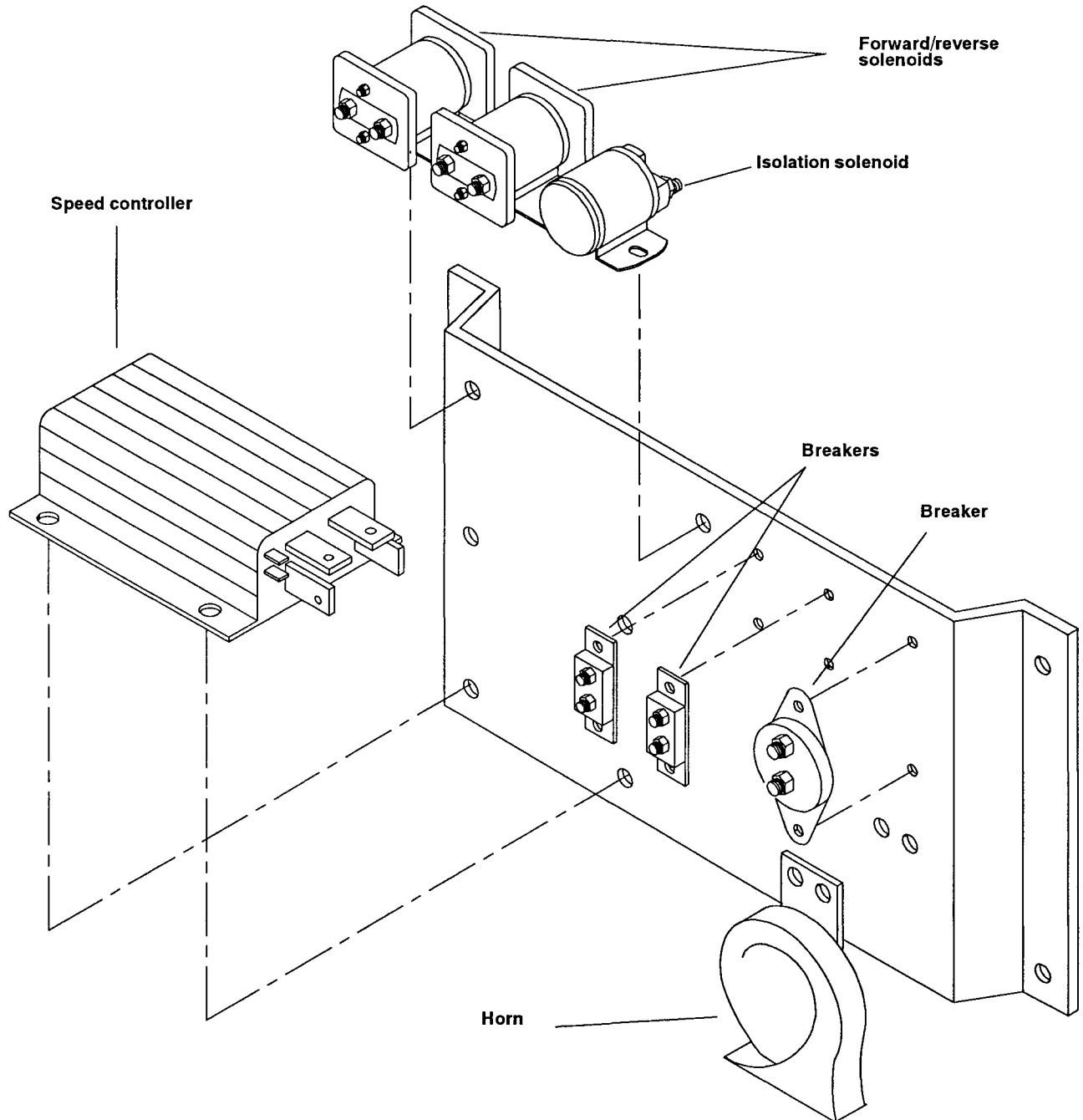

Figure 19 - Control panel assembly

## Solenoid Assembly

To repair or replace solenoids perform the following (see figure 20):

### **WARNING!**

**Disconnect the main battery leads before working on any part of the vehicle's electrical system.**

- 1** Remove wires and buss bars.

**Note:** Mark the position of all wires and buss bars prior to removal. Make sure they are put back in their original position.

- 2** Remove screws, nuts and washers on solenoids.
- 3** Remove solenoids from panel.
- 4** To install solenoids, reverse Steps 1 - 3.

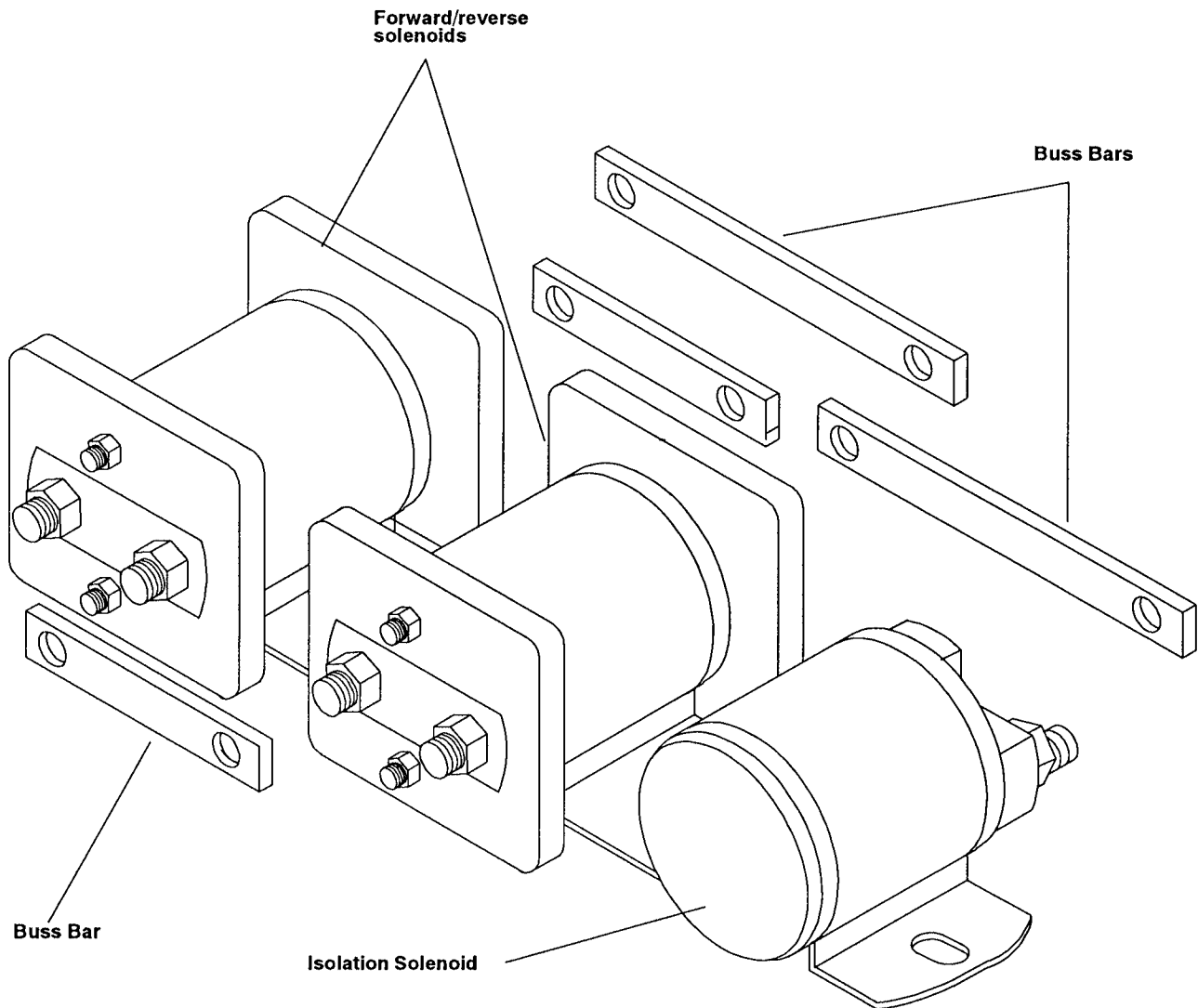

Figure 20 - Solenoid assembly

## Testing the Accelerator Module

### **WARNING!**

**Disconnect the main battery leads before working on any part of the electrical system.**

- 1** Unplug the accelerator wire harness.
- 2** Using an accelerator module test box, plug the pigtail into the accelerator module.
- 3** Connect the B+ and B- terminals on the test box to the battery positive and negative terminals.

**Note:** *Make sure the batteries are in good condition and charged.*

- 4** Set the V.O.M. on the test box to DC volt range to make the following measurements. Measurements are made by selecting the desired pin. All readings must agree with the values shown in the tables below.
- 5** With the pedal up, the following measurements should be observed.

Pin Position	Pedal Up
2	0 Volts
4	Battery Voltage
5	0 Volts
6	0 Volts

- 6** Slowly depress the pedal. When pin #5 measures 36 volts, the following additional measurements should be observed.

Pin Position	#5 at Battery Voltage
2	6.0 - 6.3 Volts
4	Battery Voltage
5	Battery Voltage

- 7** With the pedal fully depressed, the following measurements should be observed.

Pin Position	Pedal Fully Depressed
2	11.0 - 11.5 Volts
4	Battery Voltage
5	Battery Voltage
6	Battery Voltage

- 8** Replace the accelerator module if the readings obtained are not within +/- 10% of the values shown in the tables. There are no adjustments within the accelerator module.
- 9** Unplug the test pigtail and plug in the accelerator wire harness.

## Testing for Solenoid and Keyswitch Operation

---

To check solenoid and keyswitch operation, perform the following:

- 1** Raise and brace the rear of the vehicle. The drive wheels must not touch the ground because they will be turning during parts of this test.

### **WARNING!**

---

**Always use jack stands of adequate capacity when supporting the vehicle. Perform this procedure only on a flat, level surface.**

---

- 2** Place the forward/reverse switch in the off (center) position.
- 3** Connect a voltmeter across the coil terminals of the isolation solenoid.
- 4** Turn the keyswitch on and depress and hold the pedal at the position where the first microswitch in the accelerator module operates.
- 5** The voltmeter should indicate the full battery voltage.
- 6** Measure voltage across the isolation solenoid contacts. The meter should indicate zero volts.
- 7** Place the forward/reverse switch in reverse.

### **WARNING!**

---

**The wheels will be turning during this test.**

---

- 8** Measure the voltage across the reverse solenoid coil. You should measure full battery voltage.
- 9** Measure the voltage across the reverse solenoid contacts. The meter should indicate zero volts.
- 10** Place the forward/reverse switch in forward.
- 11** Measure the voltage across the forward solenoid coil. You should measure full battery voltage.
- 12** Measure the voltage across the forward solenoid contacts. The meter should indicate zero volts.
- 13** If any of the solenoid contacts do not indicate zero volts while battery voltage is measured on the associated coil, replace the solenoid.
- 14** If any of the coil measurements are incorrect, check for loose or misconnected wires, faulty keyswitch or forward / reverse switch.

## Speed Controller

### Testing Speed Controller Wiring

To test the operation of the speed controller in the vehicle, perform the following:

- 1** Raise and support the rear wheels. The drive wheels must not touch the ground during this test because the wheels will be turning during parts of this test.

### **WARNING!**

**Always use jack stands of adequate capacity when supporting the vehicle. Perform this procedure only on a flat, level surface.**

**Note:** *Make sure the batteries are fully charged before proceeding.*

- 2** Make sure that the keyswitch is in the off position.
- 3** Check to see that the negative ( - ) battery terminal is connected to the B- terminal of the controller.

- 4** Connect the negative ( - ) voltmeter lead to the B- terminal on the controller.
- 5** Connect the positive (+) voltmeter lead to the battery side of the isolator solenoid.
- 6** The meter should indicate the full battery voltage.

**Note:** *If voltage is not present, check for loose wires, bad connections, or faulty main circuit breaker.*

- 7** Connect the positive (+) voltmeter lead to the controller B+ terminal.
- 8** The voltmeter should indicate a reading of 1 to 5 volts less than the full battery voltage. If the voltmeter reads full battery voltage, then the isolation solenoid contacts have welded together and the solenoid must be replaced.

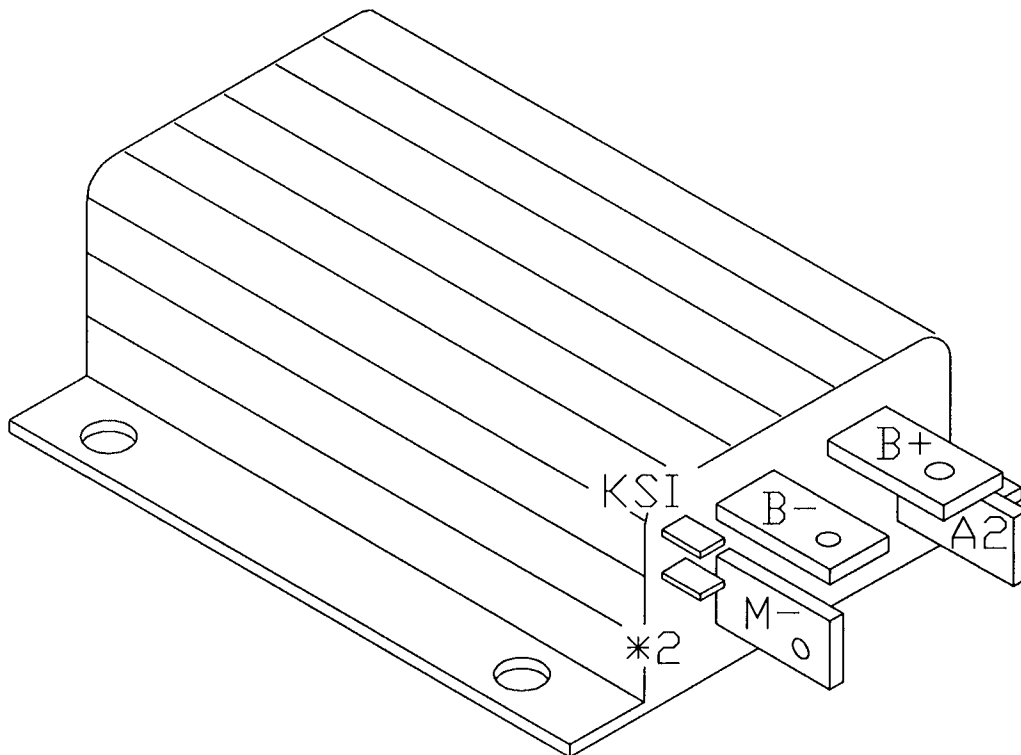

**Figure 21** - Electronic Speed Controller

If the voltage is zero or close to zero, the trouble is either a defective controller, a defective resistor across the isolator solenoid, or wiring problem. The following steps outline the test that should be made.

- 1** Trace the wire from B+ terminal on the controller to make sure it is connected correctly.
- 2** Remove and test the resistor on the isolator solenoid with an ohmmeter. The ohmmeter should read 250 ohms.

### Testing Controller Output

**Note:** *This test assumes that the accelerator module has been previously tested and is known to be functioning properly.*

**Note:** *The test is best performed with an analog type voltmeter. Digital meters may provide erratic readings.*

- 1** Raise and brace the rear of the vehicle. The drive wheels must not touch the ground because the drive wheels will be turning during parts of this test.

### **WARNING!**

**Always use jack stands of adequate capacity when supporting the vehicle. Perform this procedure only on a flat, level surface.**

- 2** Connect the voltmeter positive (+) lead to the controller M- terminal.
- 3** Connect the negative (-) meter lead to the B- terminal on the controller.
- 4** Turn on the keyswitch.
- 5** Put the forward/reverse switch in forward or reverse.

- 6** Operate the accelerator over its full travel while monitoring the voltmeter. The voltmeter should read nearly full battery voltage with the pedal at the top of its travel and drop smoothly to near zero volts with the pedal all the way down. Also, the speed of the rear wheels should progressively increase as the accelerator pedal is depressed.

- 7** If no voltage or low voltage readings are observed and the wheel speed is low, check the wiring, connections, solenoids, and motor for poor connections or open circuits.

- 8** If the voltage reading is correct at the top of the pedal travel, but does not drop, check the accelerator module input to the controller. It should vary from 6 to 11 volts with respect to the B- terminal over the full travel of the accelerator module.

- 9** Measure voltage on the KSI terminal on the controller. It should read battery voltage with the pedal fully depressed.

- 10** Measure the current in the M- lead while operating the accelerator over its full travel. The current should gradually increase as the accelerator is depressed to a level of 25 - 60 amps.

**Tip:** *Use a shunt/meter setup or a clamp-on DC ammeter to measure the current.*

- 11** If there is current in the M-lead but the wheel speed is not correct, there is likely a short in the motor or wiring.

If the above tests results are normal and the vehicle does not operate properly, the free wheeling or plug diode in the controller may be faulty.



### Checking the Plug Diode

- 1** Disconnect the battery leads.
- 2** Disconnect the A2 terminal on the controller.
- 3** Connect an ohmmeter capable of testing silicon diodes between the A2 and the B+ terminals on the controller.

The ohmmeter should show a low resistance with the leads connected one way and a high resistance with the leads reversed.

### Checking the Freewheeling Diode

- 1** Disconnect cable from the M- terminal on the controller.
- 2** Connect the ohmmeter between the M- and B+ terminals on the controller.
- 3** The ohmmeter should show a low resistance with the leads connected one way and a high resistance with the leads reversed.
- 4** If either of the diodes appear to be defective, replace the controller.

## Section 5

# ILLUSTRATED PARTS BREAKOUT

# MECHANICAL BRAKE LINKAGE

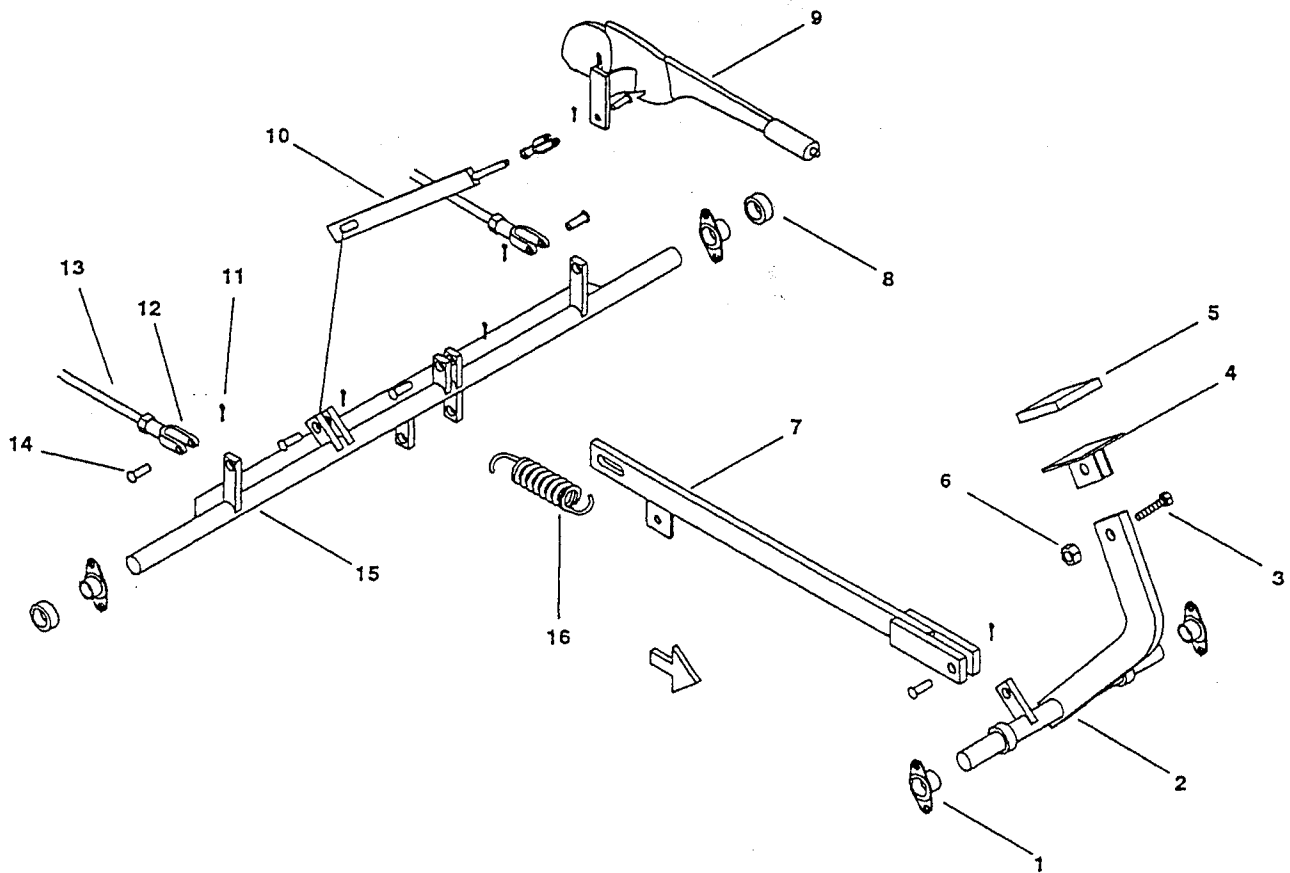



MECHANICAL BRAKE LINKAGE			
ITEM #	PART NO.	DESCRIPTION	QTY
1	80-410-20	Bearing, 2-Bolt Flange	4
2	02-380-39	Weldment, Service Brake	1
3	88-080-11	Bolt, Hex, 5/16" x 1" NC	1
4	01-432-98	Weldment, Brake Pedal	1
5	98-200-00	Pad, Rubber, Brake Pedal	1
6	88-089-81	Locknut, 5/16" NC	1
7	02-380-40	Brake Rod, Weldment	1
8	17-110-00	Collar, 3/4" Shaft	4
9	51-343-10	Lever, Park Brake	1
10	01-380-62	Weldment, Linkage, Hand Brake	1
11	88-527-11	Pin, Cotter, 1/8" x 1"	6
12	96-763-00	Clevis, 5/16"	3
13	02-380-72	Rod, Mechanical Brake	2
14	96-773-00	Pin, Clevis, 5/16" x 1" Long	6
15	01-380-23	Weldment, Shaft, Main Brake	1
16	85-223-00	Spring, Extension, 1 1/16" OD x 6 1/4"	1

# HYDRAULIC BRAKE LINKAGE AND FLUID SYSTEM

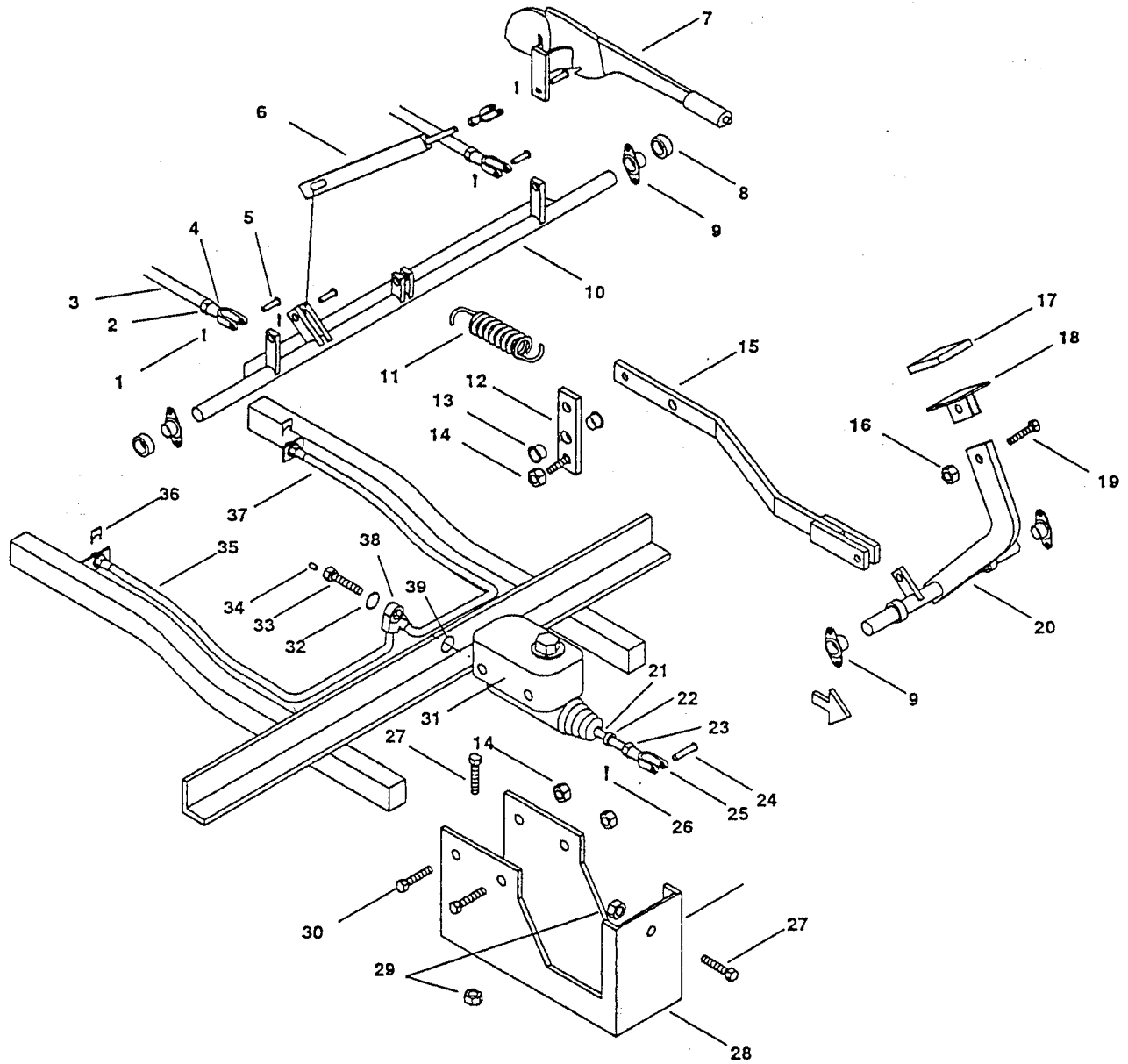



HYDRAULIC BRAKE LINKAGE AND FLUID SYSTEM			
ITEM #	PART NO.	DESCRIPTION	QTY
1	88-527-11	Pin, Cotter, 1/8" x 1"	6
2	88-099-80	Hex Nut, 5/16" NF	3
3	02-380-72	Rod, Mechanical Brake	2
4	96-763-00	Clevis, 5/16"	3
5	96-773-00	Pin, Clevis, 5/16" x 1" Long	6
6	01-380-62	Weldment, Linkage, Hand Brake	1
7	51-343-10	Lever, Park Brake	1
8	17-110-00	Collar, 3/4" Shaft	1
9	80-410-20	Bearing, 2-Bolt Flange	4
11	85-270-00	Spring Extension	1
10	01-380-23	Weldment, Shaft, Main Brake	1
13	32-215-00	Bearing, Flanged	2
14	88-109-81	Locknut, 3/8" NC	3
12	00-380-77	Weldment, Bellcrank	1
15	00-380-80	Weldment Brake, Rod, Hydraulic	1
16	88-089-81	Locknut, 5/16" NC	1
17	98-200-00	Pad, Rubber, Brake Pedal	1
18	01-432-98	Weldment, Brake Pedal	1
19	88-080-11	Bolt, Hex Head, 5/16 x 1" NC	2
20	02-380-39	Weldment, Service Brake	1
21	17-104-00	Collar, 3/8"	1
22	50-009-00	Push Rod	1
23	88-119-80	Nut, Hex Head, 3/8" NF	1
24	96-772-00	Clevis Pin, 3/8 x 1"	1
25	96-762-00	Clevis, 3/8 x 1"	1
26	88-517-09	Pin, Cotter, 3/32 x 3/4"	1
27	88-080-10	Bolt, Hex Head, 5/16 x 7/8"	4
28	00-380-79	Plate Weldment, Master Cylinder	1
29	88-089-81	Locknut, 5/16"	4
30	88-101-20	Bolt, Hex Head, 3/8 x 3" NC, Scr Gr. 5	2
31	99-510-01	Master Cylinder, Less Valve	1
32	99-571-00	Washer, Wagner #FC602	1
33	99-579-00	Bolt, Wagner #FC673	1
34	99-598-00	Fitting, 3/16" Plug	1

HYDRAULIC BRAKE LINKAGE AND FLUID SYSTEM			
ITEM #	PART NO.	DESCRIPTION	QTY
35	99-604-58	Brake Line, Formed, Right	1
36	99-576-00	Clip, Wagner #FC3052	2
37	99-604-59	Brake Line, Formed, Left	1
38	99-565-00	Y-Fitting	1
39	99-572-00	Washer, Wagner #FC603	1
40	88-149-81	Locknut, 1/2" NC (Not Shown)	1
41	00-380-78	Bell Crank With Bushing (Includes Items 12, 13, and 14)	1



This page is intentionally left blank.



# CHARGERS

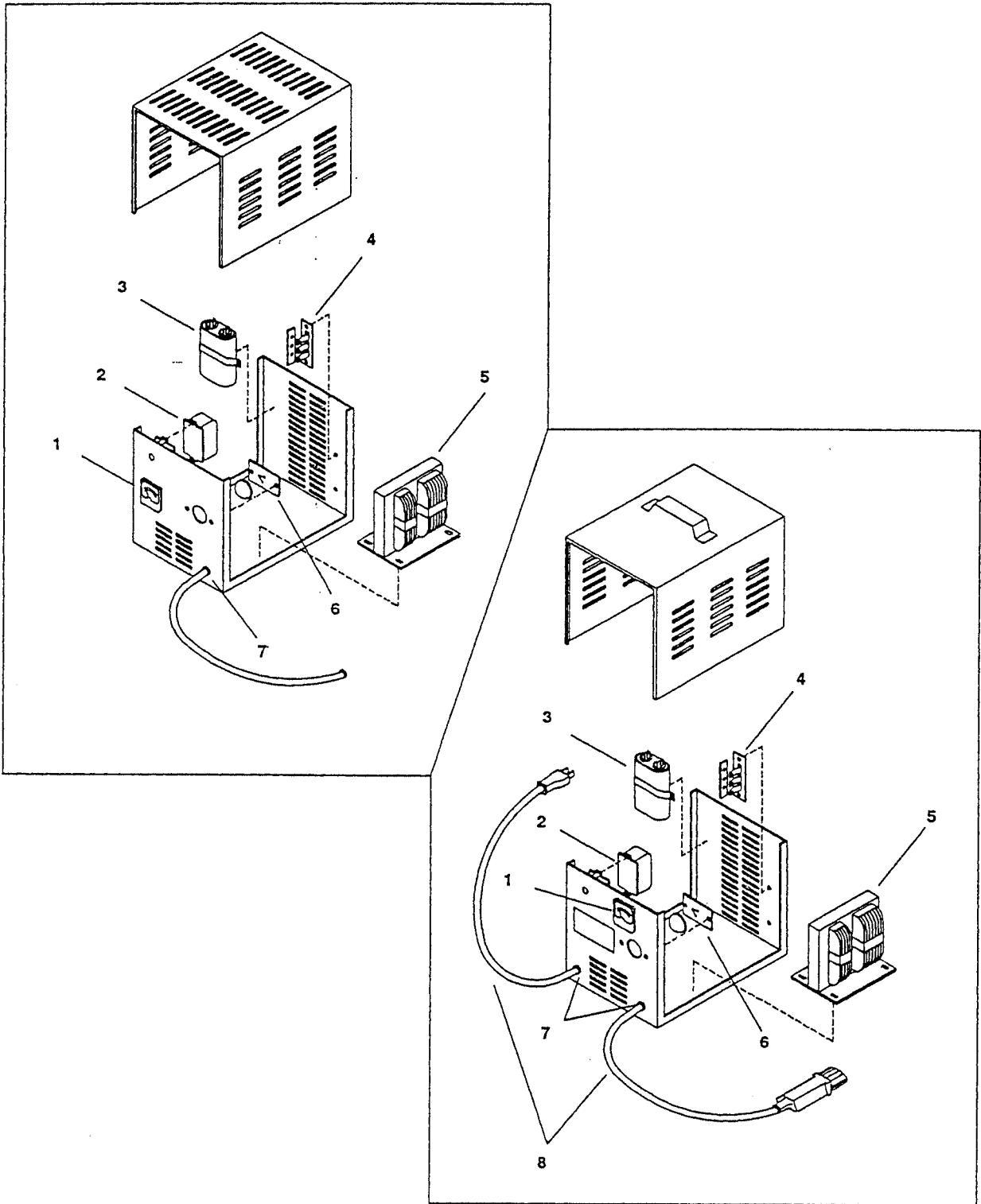

CHARGERS			
ITEM #	DESCRIPTION	PART NO.	
		BUILT-IN, Model 07460	PORTABLE, Model 07710
	COMPLETE CHARGER	79-305-05	79-305-20
1	Ammeter	79-851-10	79-851-10
2	Timer	79-805-67	79-805-63
3	Capacitor, 6 mfd, 660 V	79-902-00	79-902-00
4	Heat Sink Assembly with Diodes	79-749-13	79-749-13
5	Transformer	79-644-31	79-644-27
6	Fuse, Charger, 25A, Assembly	79-831-00	79-831-00
7	Bushing, Insulator for Harness	79-530-00	79-530-00
8	Cordset, DC, with Lester Plug, DC	N.A.	79-575-10

# FRONT AXLE

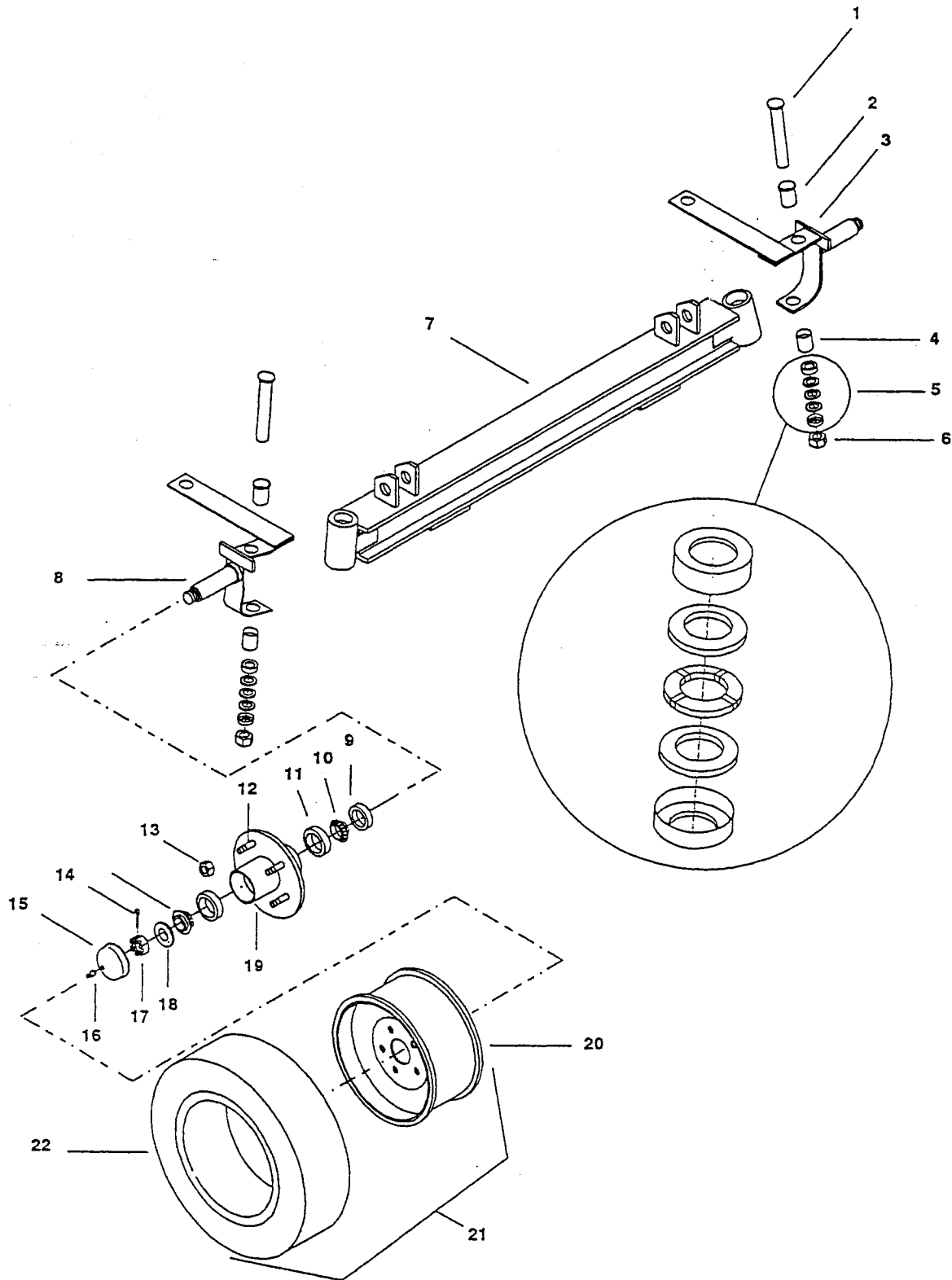

FRONT AXLE ASSEMBLY (15-380-32)			
ITEM #	PART NUMBER	DESCRIPTION	QTY.
1	21-009-10	Kingpin, with Plate, 7/8"	2
2	32-200-00	Bushing, 7/8" ID, 1" OD	2
3	14-380-93	Yoke, Front Axle, Right	1
4	32-204-00	Bushing, Bronze, 7/8" ID, 1" OD	2
5	80-309-10	Bearing, Pack, 7/8" ID	2
6	88-289-81	Locknut, 7/8", NF	2
7	15-380-31	Weldment, Front Axle	1
8	14-380-92	Yoke, Front Axle, Left	1
9	45-338-00	Seal, Oil, 1.25 ID, 1.983 OD, 0.345 W	2
10	80-017-00	Bearing, Tapered, 1" ID	4
11	80-103-00	Race, Bearing, Tapered	4
12	12-124-00	Hub, Wheel, 5-Stud, 1" Bearing	2
13	97-236-00	Nut, Lug, 1/2" Taper	10
14	88-527-11	Pin, Cotter, 1/8 x 1"	2
15	92-104-00	Dust Cap with Grease Fitting (Includes # 16)	2
16	87-074-00	Grease Fitting, 3/4"	2
17	88-239-85	Slotted Nut, Hex Head, 3/4", NF	2
18	88-228-61	Washer, 3/4", SAE	2
19	96-329-00	Bolt, Hub, 1/2" NF x 1 1/4"	10
20	12-012-00	Wheel, 8" Dia.	2
21	13-742-00	Tire/Wheel Assembly, 5.70 x 8	2
22	10-081-00	Tire, 5.70 x 8, Load Range B, Hwy Tread	2

# FRONT AXLE WITH HYDRAULIC DISC BRAKES

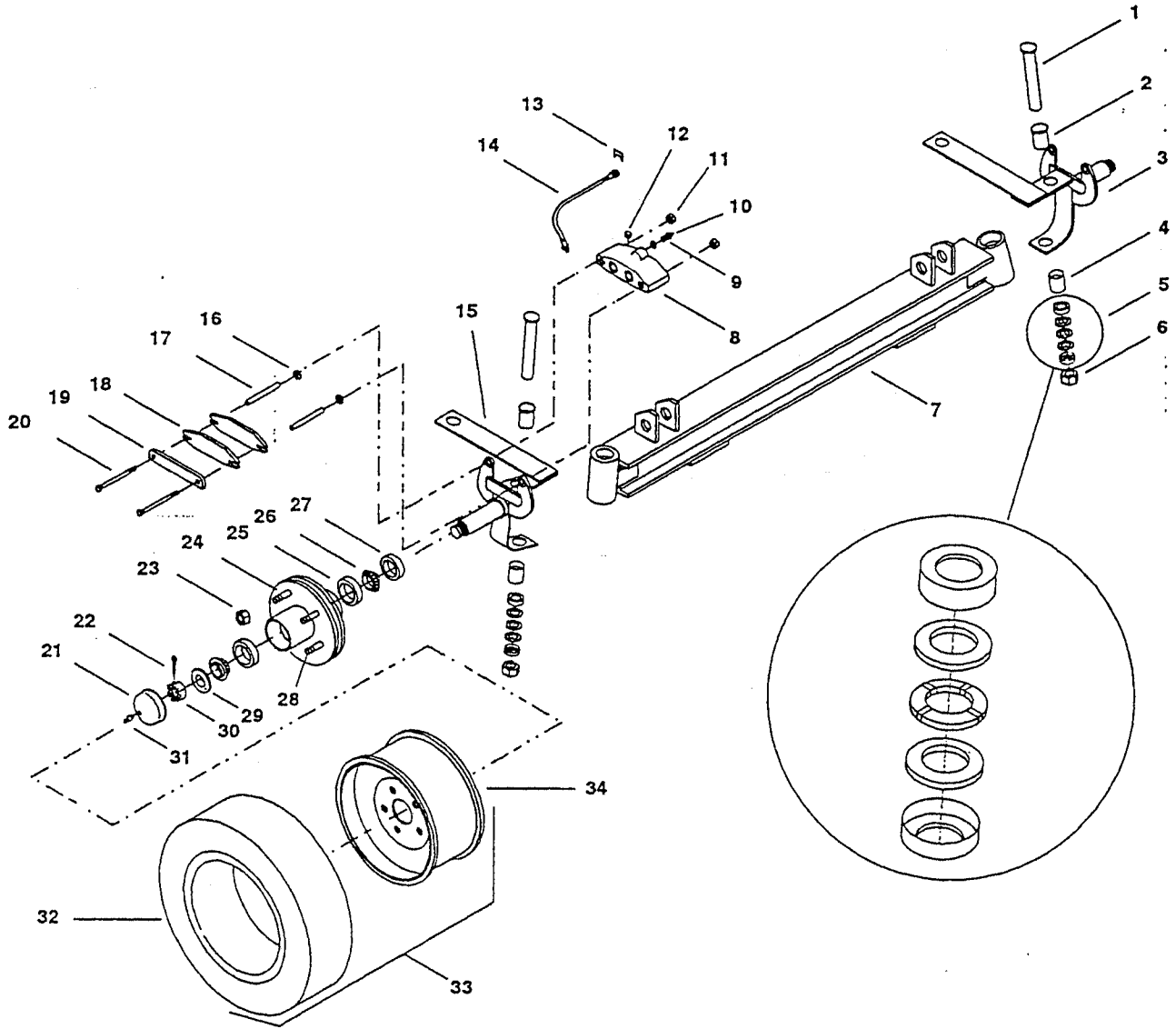

FRONT AXLE ASSEMBLY, HYDRAULIC BRAKE (15-380-50)			
ITEM #	PART NUMBER	DESCRIPTION	QTY.
1	21-009-10	Kingpin with Plate, 7/8"	2
2	32-200-00	Bushing	2
3	14-380-86	Yoke, Front Axle, w/ Hyd Brake, Right	1
4	32-204-00	Bushing, Bronze	2
5	80-309-10	Bearing, Pack	2
6	88-289-81	Locknut, 7/8", NF	2
7	15-380-31	Weldment, Front Axle	1
8	41-350-68	Kit, Hyd Disc Brake Body, Left or Right	2
9	99-588-00	Bolt, Bleeder, 1/4-28	2
10	99-588-01	Adapter, Bleeder Screw	2
11	88-069-82	Locknut, 1/4", Grade 8	4
12	95-620-00	Plug, Plastic, 1 1/32" Hole	2
13	99-576-00	Clip, Wagner # FC3052	2
14	99-580-20	Hose, Brake	2
15	14-380-85	Yoke, Front Axle, w/ Hyd Brake, Left	1
16	32-240-40	Bushing, 3/8", Teflon	4
17	41-348-52	Spacer, Disc Brake	4
18	41-348-70	Pad, Disc Brake	4
19	41-350-51	Plate, Secondary, Hyd Disc	2
20	88-067-21	Bolt, 1/4" NC x 3 3/4", Grade 8	4
21	92-104-00	Dust Cap (Includes Item # 31)	2
22	88-527-11	Pin, Cotter, 1/8 x 1"	2
23	97-236-00	Nut, Lug	10
24	12-158-10	Hub, Wheel, 5-Stud, w/ Disc, 1" Bearing	2
25	80-103-00	Race, Bearing, Tapered	4
26	80-017-00	Bearing, Tapered, 1"	4
27	45-338-00	Seal, Oil, 1.25 ID, 1.983 OD, 0.395 W	2
28	96-329-00	Bolt, Hub, 1/2" NF x 1 1/4"	10
29	88-228-61	Washer, 3/4", SAE	2
29	92-104-00	Dust Cap	2
30	88-239-85	Slotted Nut, Hex Head, 3/4", NF	2
31	87-074-00	Grease Fitting, 1/4"	2
32	10-081-00	Tire, 5.70 x 8, Load Range B, Hwy Tread	2
33	13-742-00	Tire/Wheel Assembly, 5.70 x 8	2



FRONT AXLE ASSEMBLY, HYDRAULIC BRAKE (15-380-50)			
ITEM #	PART NUMBER	DESCRIPTION	QTY.
34	12-012-00	Wheel, 8" Dia.	2
35	41-886-00	Plug, 1/8" Pipe, Hex (Not Shown)	2
36	41-350-66	Kit, Cylinder Repair (2 Boots Pistons, O-rings),	

This page is intentionally left blank.



# FRONT AXLE SUSPENSION

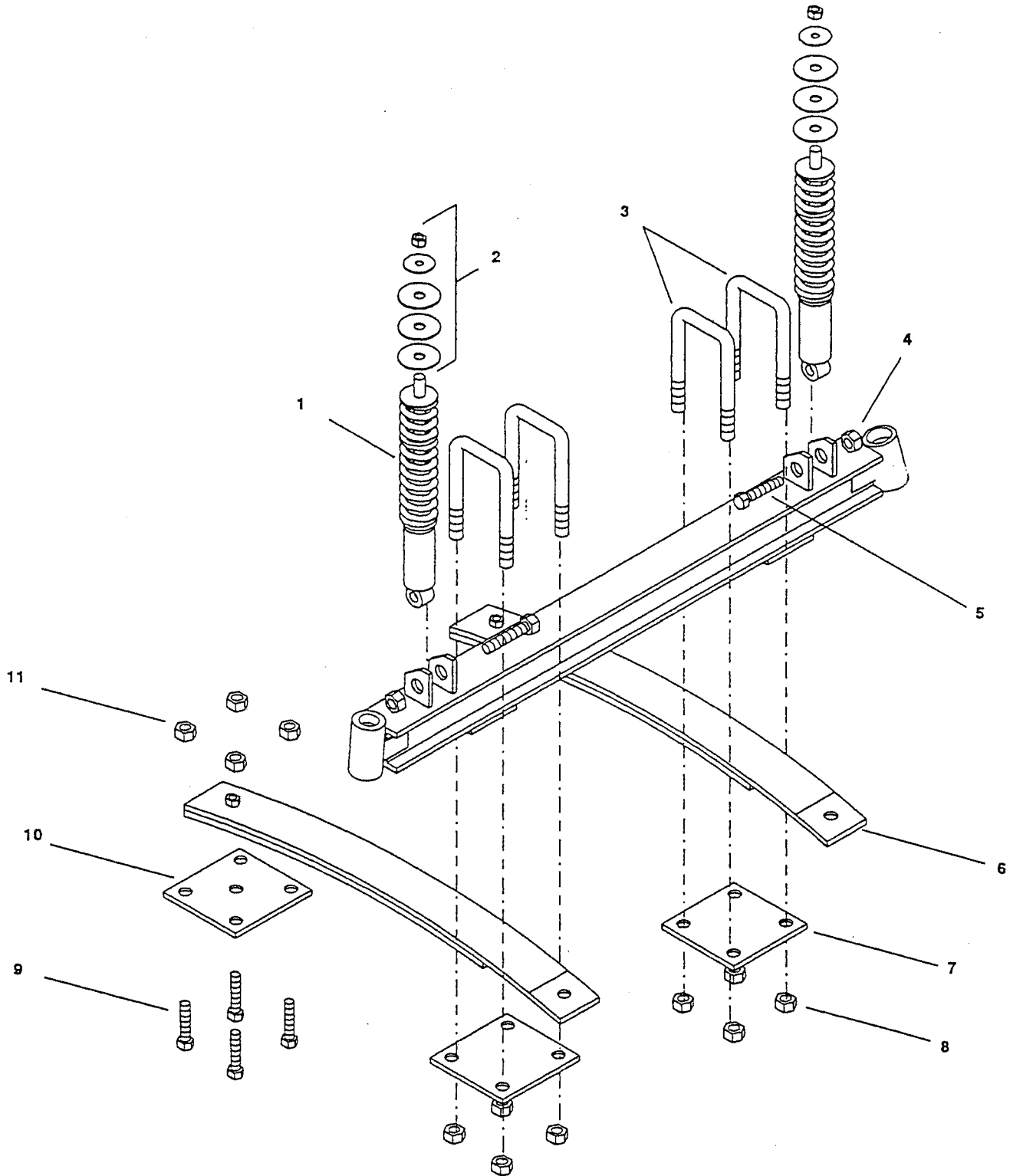

FRONT AXLE SUSPENSION			
ITEM #	PART NUMBER	DESCRIPTION	QTY.
1	86-006-00	Absorber, Shock	2
2	86-006-01	Kit, Hardware, Shock Absorber	2
3	96-123-00	U-Bolt , 3/8" x 2"	4
4	88-129-81	Nut, Lock, 7/16" NC	2
5	88-121-19	Bolt, 7/16" x 2 3/4" NC, Hex Hd	2
6	85-506-00	Spring, 2-Leaf	2
7	00-380-45	Plate, Spring Mount, Front	2
8	88-109-81	Locknut, 3/8", NC	16
9	88-100-15	Bolt, 3/8" x 1 3/4" NC, Hex Hd	8
10	02-380-50	Weldment, Plate, Spring Mount	2

# INSTRUMENT PANEL

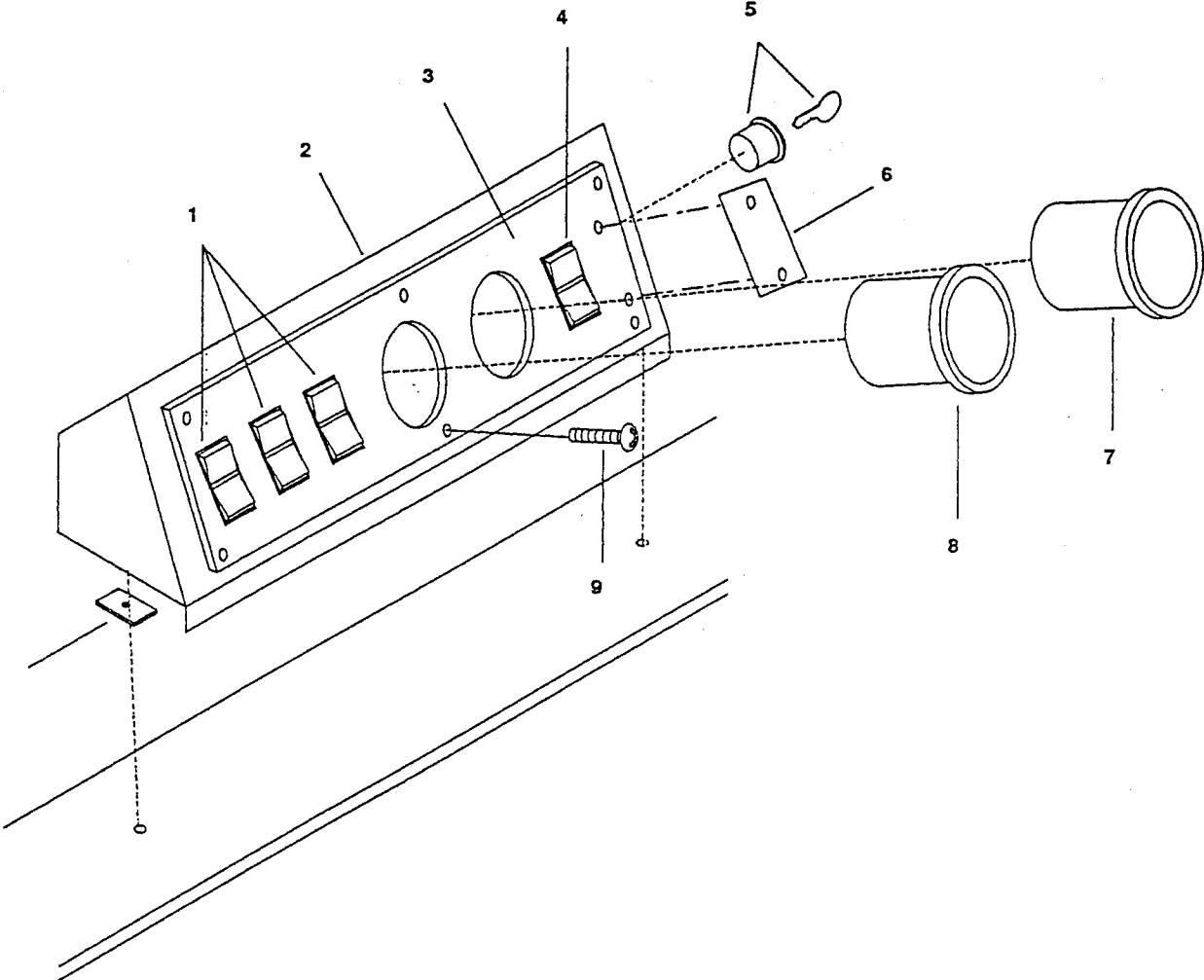

INSTRUMENT PANEL			
ITEM #	PART NUMBER	DESCRIPTION	QTY.
1	71-039-10	Switch, 1 Pl, Single Throw, with Seal	1-3
2	01-200-44	Panel, Console	1
3	94-304-10	Instrument Panel	1
4	71-039-00	Forward/Reverse Switch	1
5	71-120-00	Switch, Ignition, Keyed	1
6	94-312-00	Switch Plate, Forward / Reverse	1
7	74-000-00	Meter, Hour (optional)	2
8	74-009-00	Indicator, Battery Discharge	1
9	88-817-07	Screws, Dash, #8 x 1/2"	1
10	97-211-20	U-Clip, 1/4 - 20 (Not Shown)	2

# MASTER CYLINDER

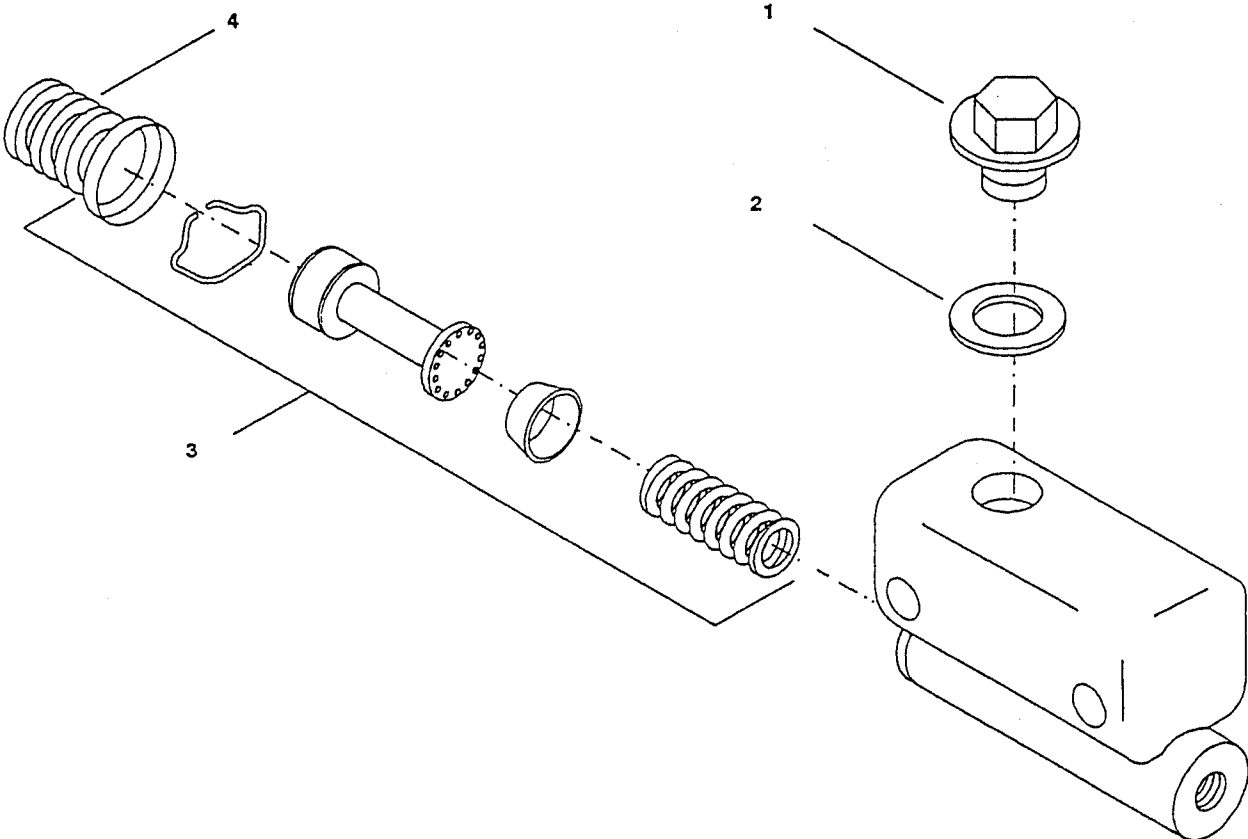



MASTER CYLINDER (Less Valve) (99-510-01)			
ITEM #	PART NO.	DESCRIPTION	QTY
1	99-510-52	Cap, Master Cylinder	1
2	99-510-53	Gasket, Cap, Master Cylinder	1
3	99-510-61	Repair Kit, Master Cylinder *	1
4	99-510-51	Rubber Boot, Master Cylinder	1

Note: Residual Pessure Valve (not shown) is not used with disc brakes.

# MOTOR

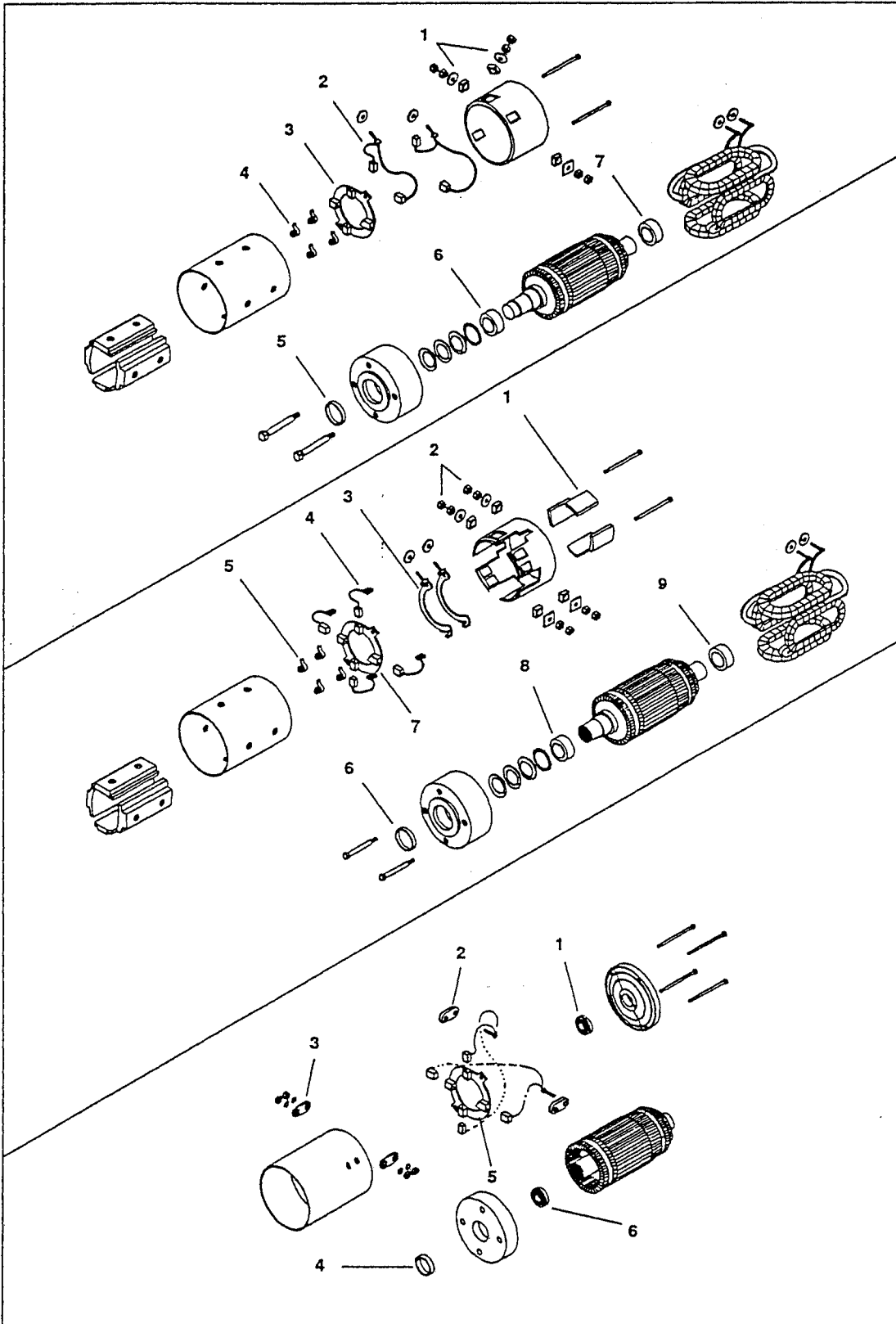

MOTOR (5BC48JB754B)			
ITEM #	PART NUMBER	DESCRIPTION	QTY.
1	70-250-00	Insulator Kit	1
2	70-104-00	Assembly, Brush, with Stud	2
3	70-172-00	Assembly, Brush Holder (without brushes)	1
4	85-412-00	Springs, Brush Extension	4
5	45-506-00	Seal, Oil	1
6	80-504-00	Ball Bearing, Pulley End	1
7	80-200-00	Ball Bearing, Commutator End	1
MOTOR (5BC49JB399C)			
ITEM #	PART NUMBER	DESCRIPTION	QTY.
1	30-802-00	Cover, Brush	4
2	70-210-62	Insulator Kit, Motor Terminals	1
3	70-195-10	Connector, Terminal to Brushes	2
4	70-105-00	Brush, Motor	4
5	85-412-00	Springs, Brush Extension	4
6	45-508-00	Seal, Oil	1
7	70-188-00	Assembly, Brush Holder (without brushes)	1
8	80-504-00	Ball Bearing, Pulley End	1
9	80-200-00	Ball Bearing, Commutator End	1
MOTOR (5BC8JB86110A)			
ITEM #	PART NUMBER	DESCRIPTION	QTY.
1	80-209-00	Ball Bearing, Commutator End	1
2	70-210-51	Bushing, Insulator	2
3	70-210-50	Bushing, Insulator	2
4	45-508-00	Seal, Oil	1
5	<del>70-104-00</del> →	Brush Mechanism, with <del>Brushes</del> <sup>SPRINGS</sup> and Terminal Screws <b>70-172-15</b>	1
6	80-504-00	Ball Bearing, Pulley End	1

-- 70-104-15 BRUSH PAIR



# REAR AXLE DIFFERENTIAL FOR MECHANICAL DISC BRAKES

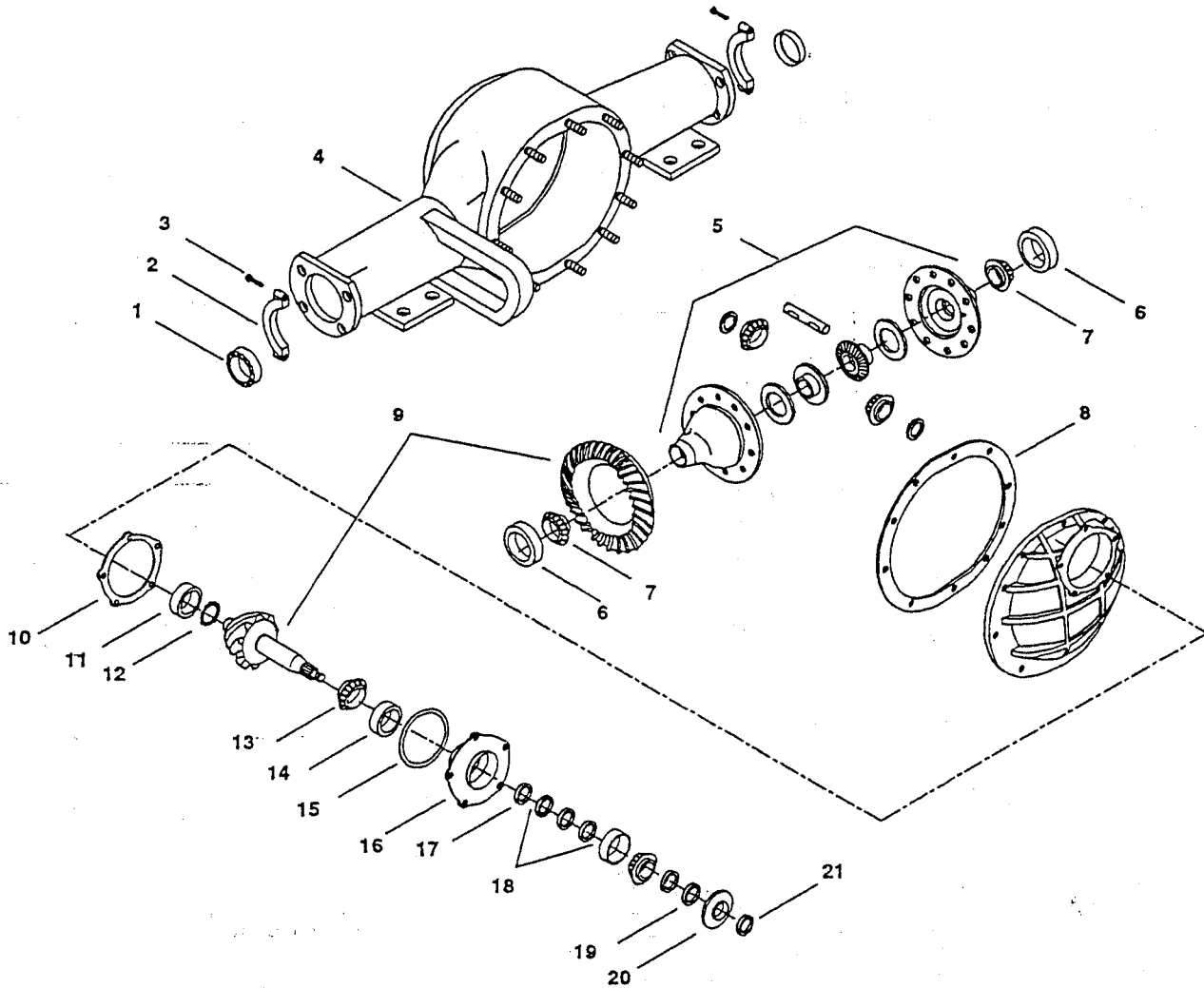

REAR AXLE DIFFERENTIAL, F3 MECHANICAL DISC			
ITEM #	PART NUMBER	DESCRIPTION	QTY.
1	<del>80-500-00</del>	Ball Bearing, Rear Axle <b>80-491-00</b>	2
2	41-350-05	Clip, 2-hole, with Tab	2
3	88-140-16	Screw, Hex Head Cap, 1/2 x 2"	2
4	44-341-42	Assembly, Differential, 3.00:1, Belt Drive *	1
4A	44-341-21	Assembly, Differential, 3.25:1, Power Traction (Optional) *	1
4B	44-341-20	Assembly, Differential, 2.75:1, Power Traction (Optional) *	1
5	41-715-00	Differential, Gear Case, Sm Carrier Bearing, 1.628 Dia.	1
6	80-127-00	Race, Bearing, Tapered	2
7	80-511-00	Bearing, Roller, Tapered	2
8	45-051-00	Gasket, Differential Housing	1
9	31-261-00	Gear Set, Ring and Pinion, 3.00:1 Belt Drive	1
9A	31-260-00	Gear Set, Ring & Pinion, 2.75:1 (Optional)	1
9B	31-262-00	Gear Set, Ring & Pinion, 3.25:1 (Optional)	1
10	41-720-00	Shim, Pinion	1
11	80-557-00	Bearing, Ball, Pinion	1
12	41-721-00	Retainer, Bearing	1
13	80-556-00	Bearing, Roller, Tapered	2
14	80-139-00	Race, Bearing, Tapered	2
15	80-710-00	O-Ring, Pinion	1
16	44-341-91	Flange, Pinion, Belt Drive	1
16A	44-341-90	Flange, Pinion, Power Traction w/ Races	1
17	16-422-00	Spacer, Pinion Bearing F3	1
18	16-440-00	Spacer, .002"	2-6
18A	16-441-00	Spacer, .005"	2-6
18B	16-442-00	Spacer, .010"	0-2
19	16-422-10	Spacer, Pinion Bearing, .280, F3	1
20	45-341-00	Oil Seal, Drive Pinion Shaft	1
21	97-250-00	Nut, Pinion, 3/4"-20	1

\* Note: Does not include Gasket

# REAR AXLE DIFFERENTIAL FOR HYDRAULIC DISC BRAKES

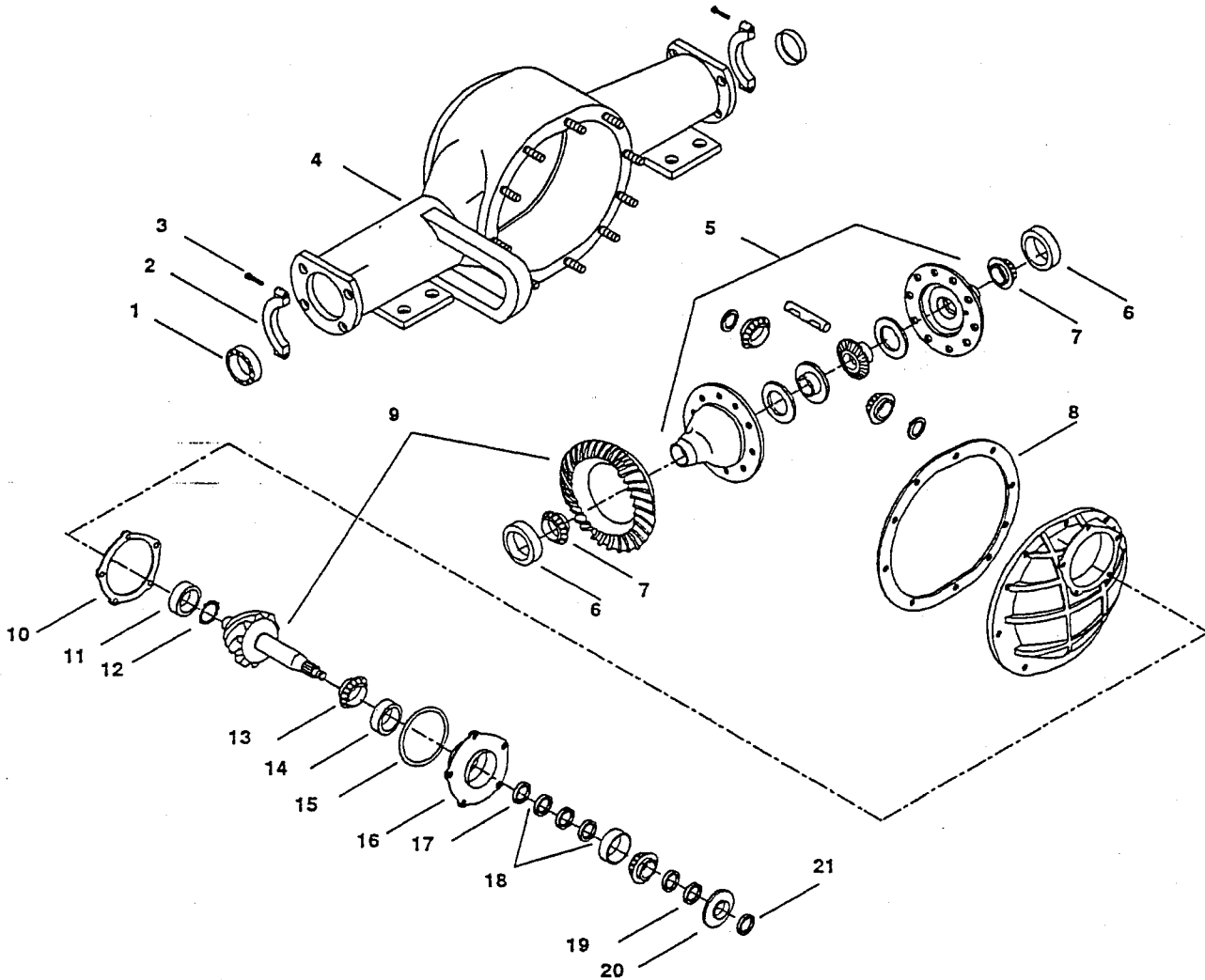

REAR AXLE DIFFERENTIAL, F2 HYDRAULIC DISC			
ITEM #	PART NUMBER	DESCRIPTION	QTY.
1	80-503-00	Ball Bearing, Rear Axle	2
2	41-350-05	Clip, 2-hole, with Tab	2
3	88-140-16	Screw, Hex Head Cap, 1/2 x 2"	2
4	44-340-40	Assembly, Differential, 2.69/2.70/2.75:1,Belt Drive	1
4A	44-340-20	Assembly, Differential 2.69/2.70/2.75:1, Power Traction *	1
5	41-712-00	Differential, Gear Case, Sm Carrier Bearing, 1.628 Dia.	1
5A	41-713-00	Differential, Gear Case, Lg Carrier, 1.784 Dia.	1
6	80-129-00	Race, Bearing, Tapered	2
7	80-513-00	Bearing, Roller, Tapered	2
8	45-042-00	Gasket, Differential Housing	1
9	31-235-00	Gear Set, Ring and Pinion, 2.75:1	1
10	41-711-00	Shim, Pinion	1
11	80-555-00	Bearing, Ball, Pinion	1
12	41-714-00	Retainer, Bearing	1
13	80-554-00	Bearing, Roller, Tapered	2
14	80-125-00	Race, Bearing , Tapered	2
15	80-702-00	O-Ring, Pinion	1
16	44-340-91	Flange, Pinion, Belt Drive, w/ Races	1
16A	44-340-90	Flange, Pinion, Power Traction, w/ Races	1
17	16-419-00	Spacer, .002"	2-6
17A	16-441-00	Spacer, .005"	2-6
17B	16-420-00	Spacer, .010"	0-2
18	45-339-00	Oil Seal, Drive Pinion Shaft, Belt Drive	1
19	16-418-00	Spacer, Pinion Bearing, .140 Belt Drive	1
20	16-422-00	Spacer, F2 Axle	1
21	97-250-00	Nut, Pinion, 3/4"-20	1
* Note: Assembly Does Not Include #5 Gasket.			

# REAR AXLE PULLEY, MOTOR MOUNTS

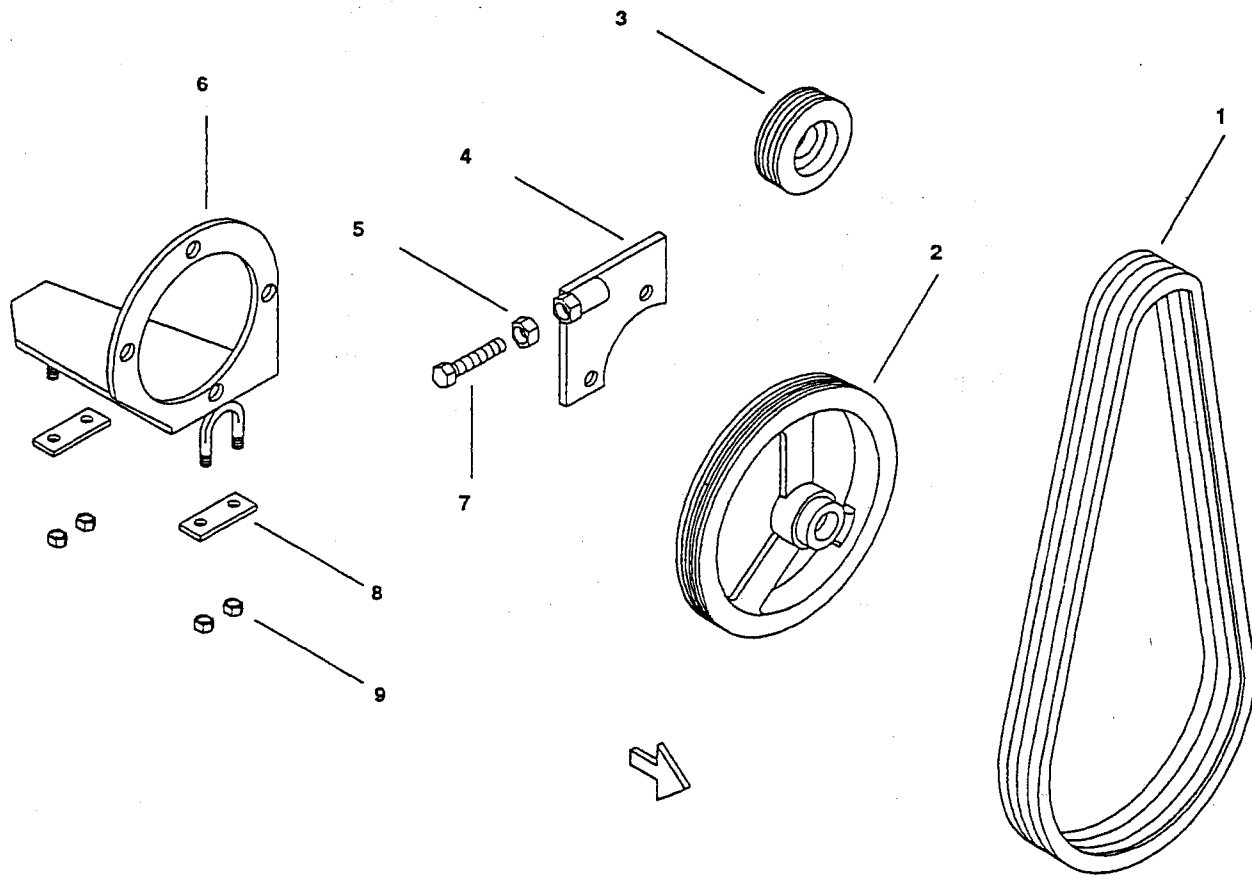

REAR AXLE PULLEY			
ITEM #	PART NUMBER	DESCRIPTION	QTY.
1	30-621-00	V-Belt, 3V425	4
1A	30-620-00	Belt, 3VX400, Hyd. Disc	4
2	30-121-00	Pulley, Large <i>MECH. DISC.</i>	1
2A	30-121-10	Pulley, Large, Hyd. Disc	1
3	30-169-00	Pulley, Std, 2.65 Dia.	1
3A	30-160-00	Pulley, 3.15 OD (Optional)	1
3B	30-158-00	Pulley, 2.43 O.D., Hyd. Disc	1
4	00-380-97	Weldment, Motor Adjuster	1
4A	41-381-10	Weldment, Motor Adjuster, Hyd. Disc	1
5	88-149-80	Nut, Hex Head, 1/2", NF	1
6	00-380-96	Mount, Motor	1
7	70-422-00	Strap, Motor Mount	2
8	88-109-87	Nut, Keps, 3/8"	4
9	96-316-00	Bolt, 1/2" NC x 3", All Thread	1

# POWER TRACTION DRIVE

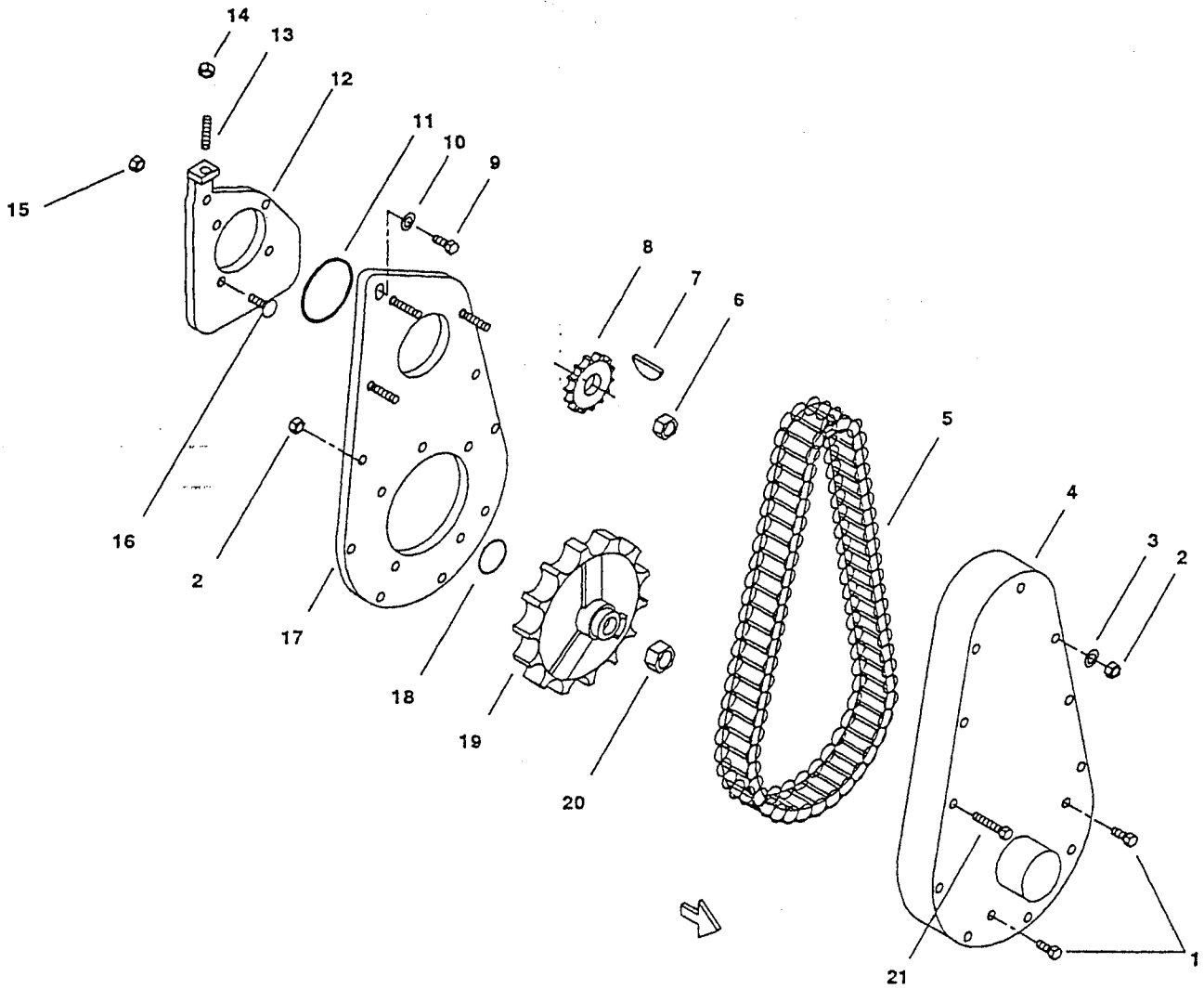

POWER TRACTION DRIVE			
ITEM #	PART NUMBER	DESCRIPTION	QTY.
1	41-989-00	Drain Plug, 1/4" Pipe	3
2	88-089-81	Lock Nut, 5/16"	12
3	88-088-61	Washer, 5/16"	3
4	43-201-30	Cover, Chain Case	1
5	30-504-20	Chain, SSG, 13/16 W 37 1/2 L (For 15/8 Sprockets)	1
5A	30-507-10	Chain, SSG 13/16 W 32.25 L (For 15/59 Tooth Sprockets)	1
6	88-239-82	Nut, 3/4 NF	1
6A	97-242-00	Nut, 3/4 NF, Turned Down	1
7	97-100-00	Woodruff Key, 1/8" x 5/8"	1
8	30-80-00	Sprocket, 15 Tooth	1
8A	30-081-00	Sprocket, 14 Tooth *	1
9	88-101-13	Bolt, 3/8 NC x 1 1/4", Grade 5	5
10	88-108-60	Washer, 3/8"	4
11	80-703-00	O-Ring	1
12	70-454-00	Plate, Motor Mount	1
13	88-087-11	Set Screw, 5/16 NC x 1"	1
14	88-089-80	Nut, 5/16 NC	1
15	88-109-87	Keps Nut, 3/8 NC	3
16	88-103-09	Bolt, 3/8 NC x 3/4", FH	4
17	44-353-10	Backing Plate, Chain Case, Mech. Disc	1
17A	44-352-54	Backing Plate, Chain Case, Hyd. Disc	1
18	16-418-00	Spacer, 0.140, Mech. Disc	1
18A	16-422-00	Spacer, Pinion Bearing, Mech. Disc	1
19	30-94-00	Sprocket, 81 Tooth, Mech. Disc	1
19A	30-093-00	Sprocket, 81 Tooth, Hyd. Disc	1
19B	30-095-00	Sprocket, 59 Tooth, Mech. Disc	1
20	97-250-00	Nut, Pinion, 3/4-20	1
21	88-080-19	Bolt, 5/16 NC x 2 3/4"	9

\* Note: 14 tooth sprocket requires (4A) nut.



# REAR AXLE SUSPENSION

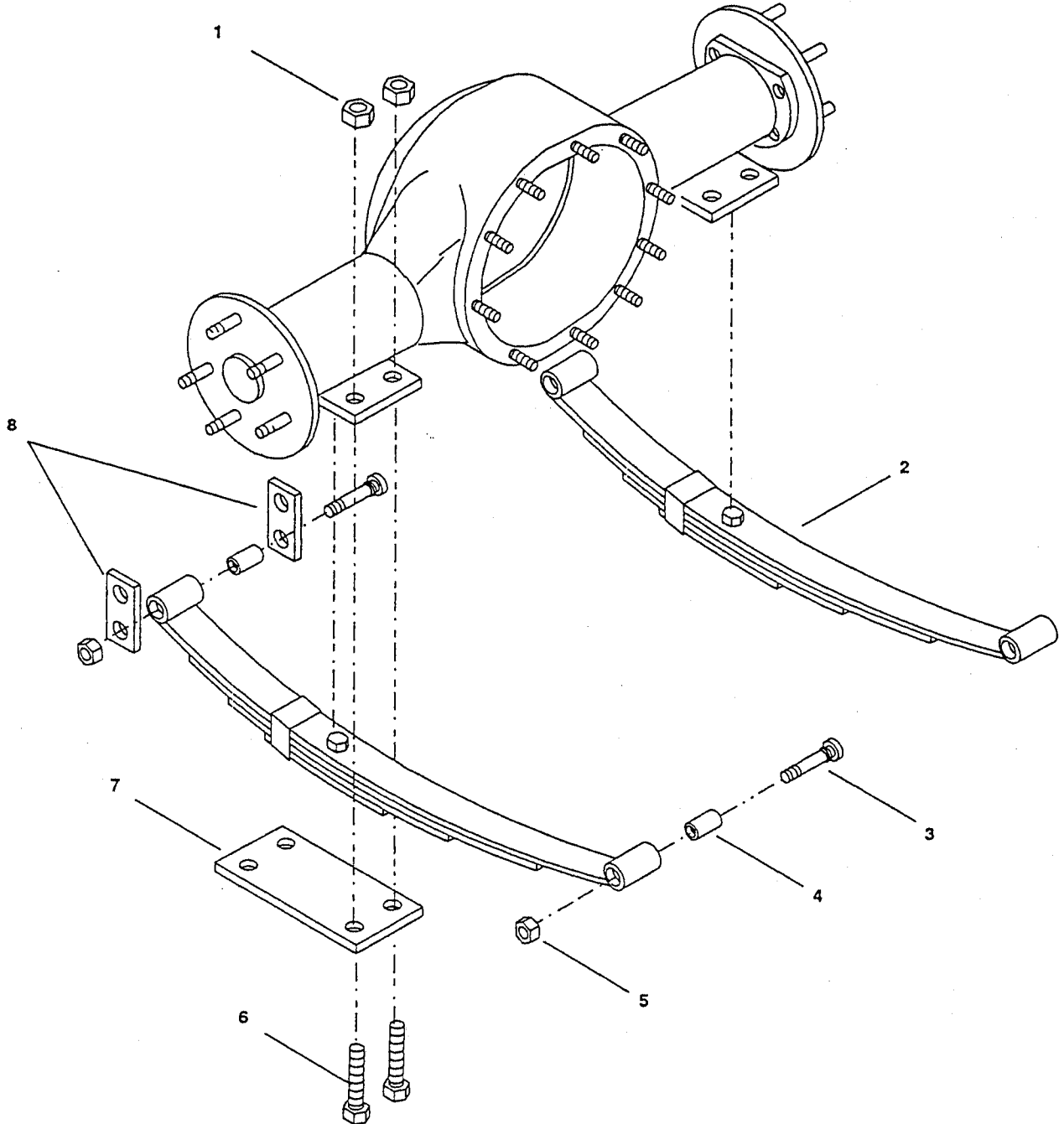

REAR AXLE SUSPENSION			
ITEM #	PART NUMBER	DESCRIPTION	QTY.
1	88-109-87	Keps Nut, 3/8 NC	8
2	85-507-00	Leaf Spring	2
3	96-248-00	Bolt, Shackle	6
4	32-213-00	Bushing, Nylon	6
5	88-169-81	Lock Nut, 9/15 NC	6
6	88-100-15	Bolt, NC, 3/8 x 1 3/4"	8
7	16-861-00	Spring Pad	2
8	16-871-00	Strap, Shackle	4

# REAR MECHANICAL BRAKES

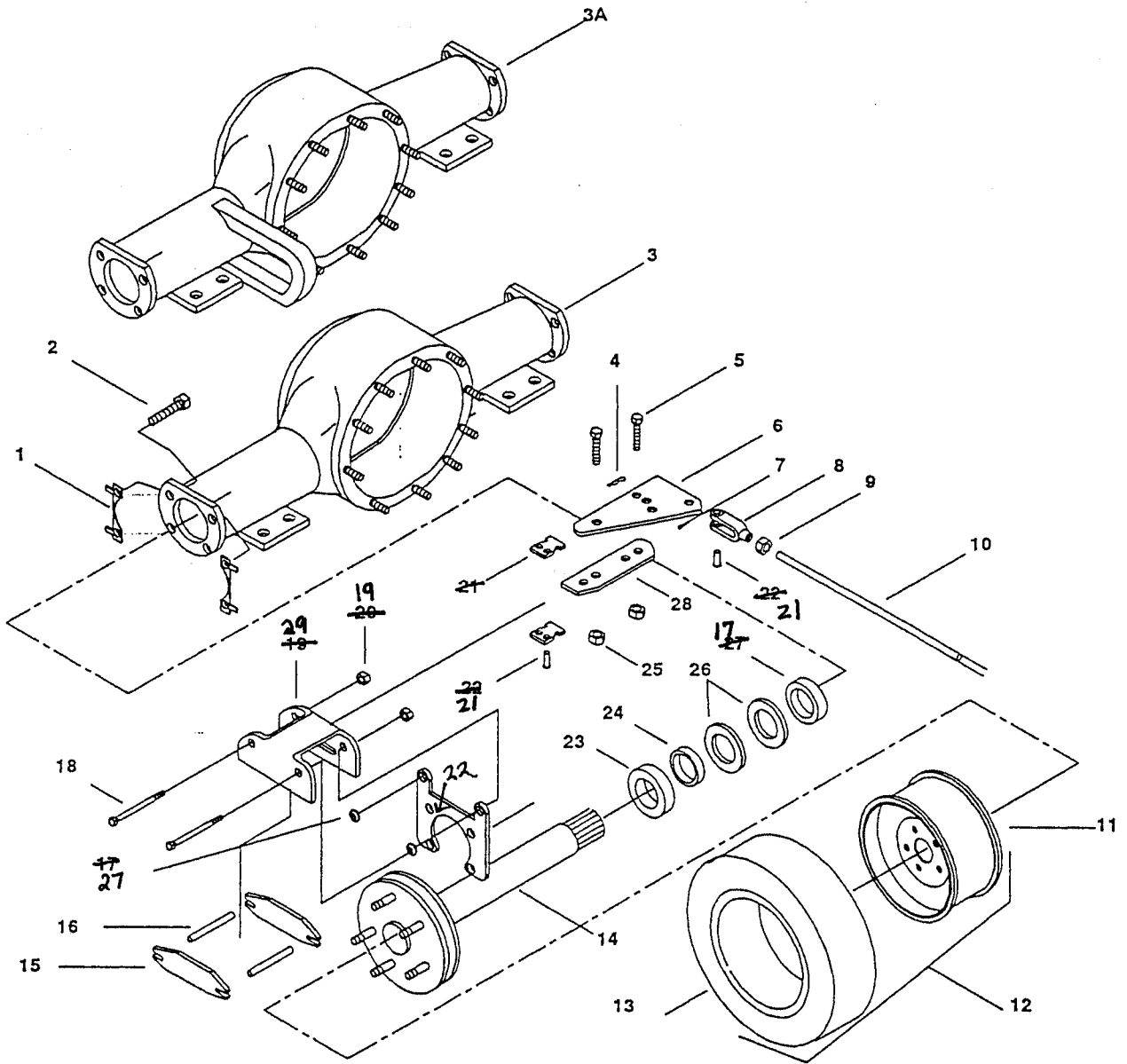

REAR MECHANICAL BRAKES			
ITEM #	PART NUMBER	DESCRIPTION	QTY.
1	41-348-59	Clip with Double Locking Tabs	4
2	96-328-00	Bolt, Special Head, 3/8" x 5/8"	8
3	41-301-40	Housing, Rear Differential, Belt Drive	1
3A	41-301-41	Housing, Rear Diff, Pwr Tract	1
5	88-080-09	Bolt, NC, 5/16 x 3/4, 4	
6	02-380-73	Lever, Mechanical Brake	2
7	88-527-11	Cotter Pin 1/8 x 1", Steel	2
8	96-765-00	Clevis, 5/16 NF-LF	2
9	88-099-81	Nut, 5/16 NF, Left-hand Thread	2
10	02-380-72	Rod, Mechanical Brake	2
11	12-012-00	Wheel, 8" Dia	2
12	13-742-00	Assy, Tire and Wheel, 5.70 x 8, Load Range B	2
13	10-081-00	Tire, 5.70 x 8, Load Range B	2
14	41-151-11	Axle, Rear w/ Bearing & Lugs	2
15	41-348-70	Pad, Disc Brake	4
16	41-348-52	Spacer, Disc Brake	4
18	88-067-18	Bolt, Hex Head, 1/4" x 2 1/2"	4
20	41-348-54	Plate, Pivot	4
<del>74</del>	97-300-10	Cotter Pin, 5/16", Stainless Steel	2
19	88-069-82	Locknut, 1/4" NC	4
25	88-089-81	Lock Nut, 5/16" NC	4
21	96-773-00	Pin, Clevis, 5/16" x 1"	2
<del>217</del>	45-299-00	Oil Seal, 1.375 x 2.265"	2
26	45-044-00	Gasket, Axle Bearing	4
24	32-516-00	Retaining Ring	2
23	60-491-00	Bearing, Ball, Rear Axle	2
22	41-348-53	Bracket, Brake Mounting	2
27	32-240-40	Bushing, 3/8"	4
28	41-348-51	Lever, Actuating	2
29	41-348-98	Brake Assembly, Mechanical Caliper, Left	1
29A	41-348-99	Brake Assembly, Mechanical Caliper, Right	1

# REAR HYDRAULIC BRAKES

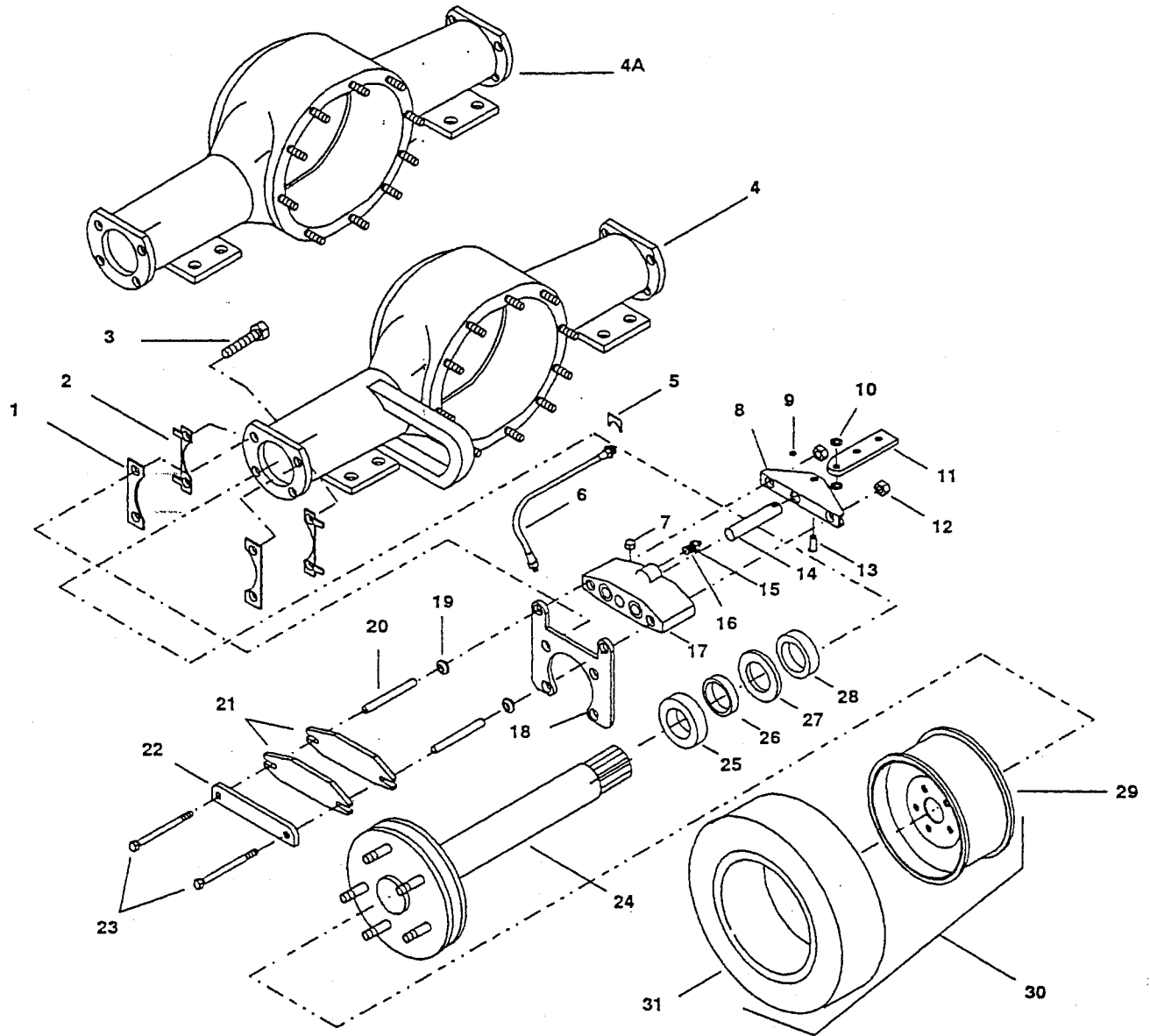

REAR HYDRAULIC BRAKES			
ITEM #	PART NUMBER	DESCRIPTION	QTY.
1	41-961-01	Shim	4
2	41-350-05	Clip, Two Hole w/ Tabs	4
3	96-327-00	Bolt, 3/8 NC x 3/4"	8
4	41-291-14	Housing, Rear Differential, Belt Drive	1
4A	41-291-15	Housing, Rear Diff, Pwr Tract (Not Shown)	1
5	99-576-00	Clip, Brake Hose	2
6	99-580-20	Hose, Brake	2
7	41-886-00	Plug, 1/8" Pipe	2
8	41-350-12	Bracket, Park Brake Lever	2
9	88-840-11	Retaining Ring, 5/16"	2
10	88-100-00	Washer	4
11	41-350-53	Arm, Parking Brake	2
12	88-069-82	Lock Nut, 1/4" NC, Grade 8	4
13	41-350-52	Clevis Pin, Hyd Disc Brake	2
14	41-350-56	Pin, Parking Brake	2
15	99-588-00	Screw, Bleeder, 1/4-28	2
16	99-588-01	Adapter, Threaded	2
17	41-350-68	Kit, Hyd Disc Brake Body, Left or Right	2
18	41-350-08	Bracket, Hyd Disc Brake	2
19	32-240-40	Bushing, 3/8"	4
20	41-348-52	Spacer, Disc Brake	4
21	41-348-70	Pad, Disc Brake	4
22	41-350-51	Plate, Secondary, Hyd Disc	2
23	88-067-21	Bolt, 1/4" NC x 3/4"	4
24	41-152-10	Axle, 17 1/8" Disc with Large Bearing	2
25	80-503-00	Bearing	2
26	32-515-00	Retaining Ring	2
27	45-044-00	Gasket	2
28	45-301-00	Oil Seal	2
29	12-012-00	Wheel, 8" Dia	2
30	13-742-00	Assy, Tire & Wheel, 5.70 x 8", Load Range B	2
31	10-081-00	Tire, 5.70 x 8", Load Range B	2
32	41-350-04	Kit, Park Brake, Hyd Disc	2
33	41-350-67	Assy, Hyd Disc Brake, Left or Right	1

# SPEED CONTROL

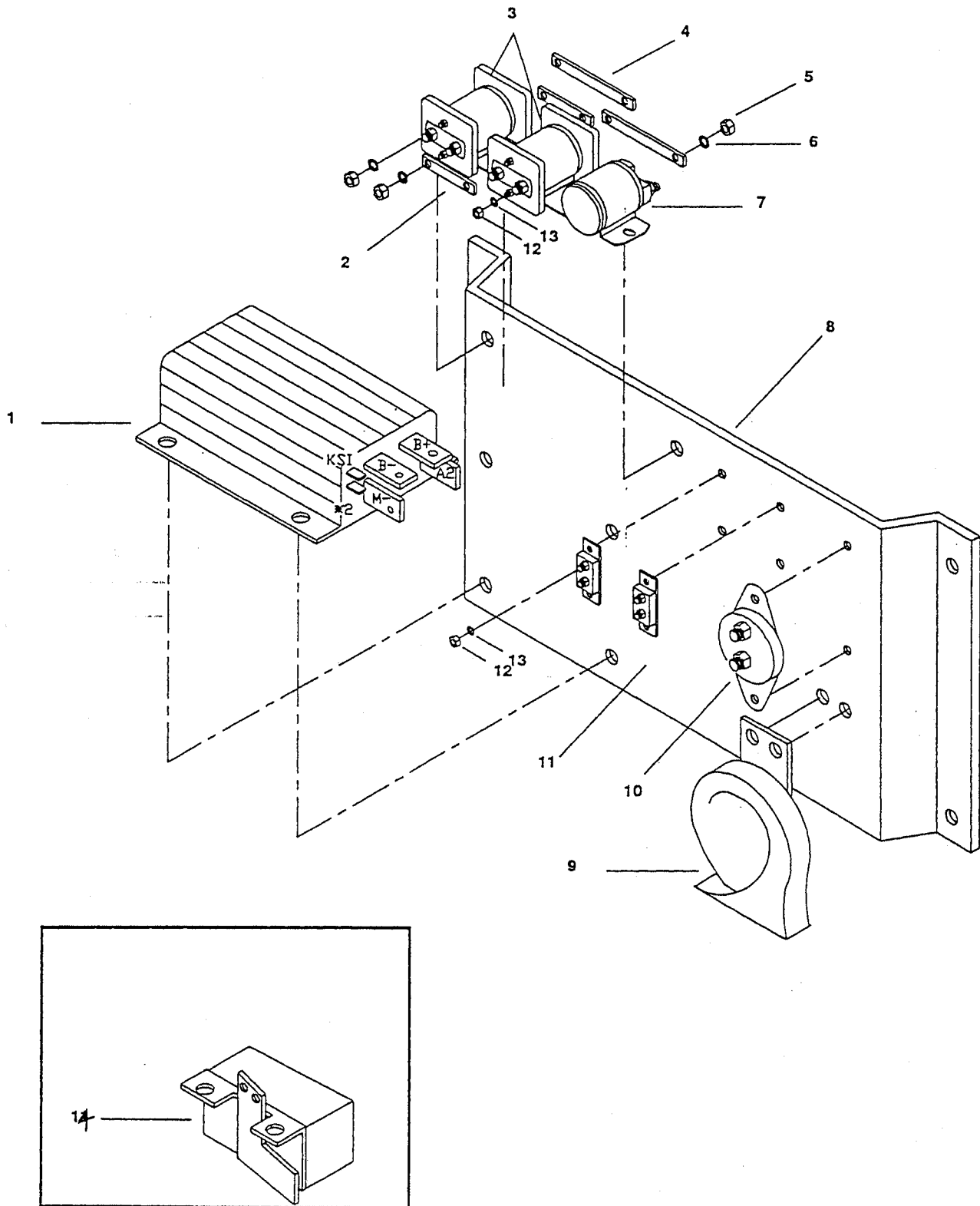

SPEED CONTROL PANEL (62-017-00) AND ACCELERATOR MODULE			
ITEM #	PART NUMBER	DESCRIPTION	QTY.
1	62-204-00	Controller, 275 A	1
2	61-838-41	Bar, Bus, 5/8 x 1/2"	2
3	72-501-39	Solenoid, SPDT, 36V, 200A	2
4	61-838-42	Bar, Bus, 3/8 x 2 5/8"	2
5	88-099-91	Nut, Hex Head, NF, 5/16" Thin Pattern	10
6	88-088-63	Lockwasher, 5/16" Int. Tooth	10
7	72-501-36	Solenoid, SPST, 36V, 100A	1
8	01-534-80	Panel, Control Mounting	1
9	73-004-20	Horn, 12V, Short Mount	1
10	79-844-00	Breaker, Klixon, Auto Reset	1
11	79-840-00	Breaker, 10 amp, Auto Reset	2
12	88-049-80	Nut, Hex Head, NF, 10-32	6
13	88-048-62	Lockwasher #10	6
14	62-033-00	Accelerator Module, Solid State (Includes # 15 - 17)	1
15	85-352-38	Spring, Torsion, Solid State Accelerator, 1	
16	71-127-01	Microswitch, Solder Tab	1
17	71-127-05	Microswitch, Snap Action, Short Lever	1
18	75-148-25	Harness, Control Panel (Not Shown)	1
19	75-149-76	Harness, Power, R-380 (Not Shown)	1
20	75-148-76	Harness, Control (Car Only) (Not Shown)	1

Accel 98-254-00 Pad  
 98-254-15 BRACKET



## STEERING ASSEMBLY

New steering gear used 10/93 and later is shown below. Old steering gear used before 10/93 is no longer available. Use 18-308-62 kit to raplace old steering gear.

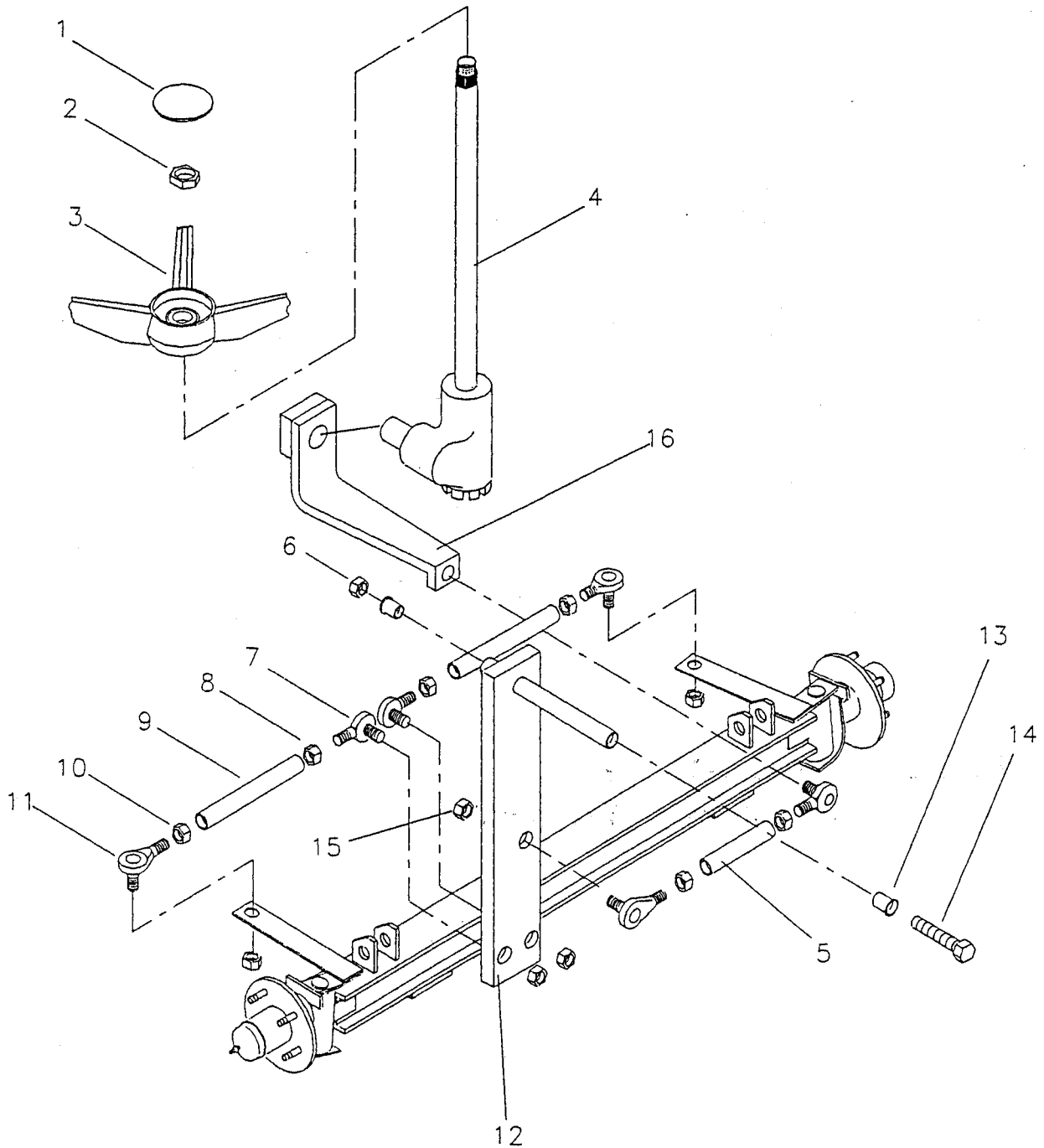

STEERING ASSEMBLY			
ITEM #	PART NUMBER	DESCRIPTION	QTY
1	19-011-25	Cap, Steering Wheel	1
2	88-199-82	Nut, Steering Wheel	1
3	19-011-20	Steering Wheel	1
4	18-308-34	Assy, Steering Gear	1
5	50-002-05	Drag Link	1
6	88-148-81	Lock Nut, 1/2" NC	1
7	86-518-01	Rod End, Left	3
8	97-202-50	Nut, 3/8" NF, LH	3
9	50-002-04	Link, Steering	2
10	88-119-80	Nut, 3/8" NF	3
11	86-518-00	Rod End, Right	3
12	02-380-64	Weldment, Steering Arm	1
13	32-215-00	Bushing, Flanged	2
14	88-140-32	Bolt, 1/2 x 7"	1
15	88-119-81	Lock Nut, 3/8" NF	6
16	00-380-99	Pitman Arm	1

## VEHICLE OPTIONS

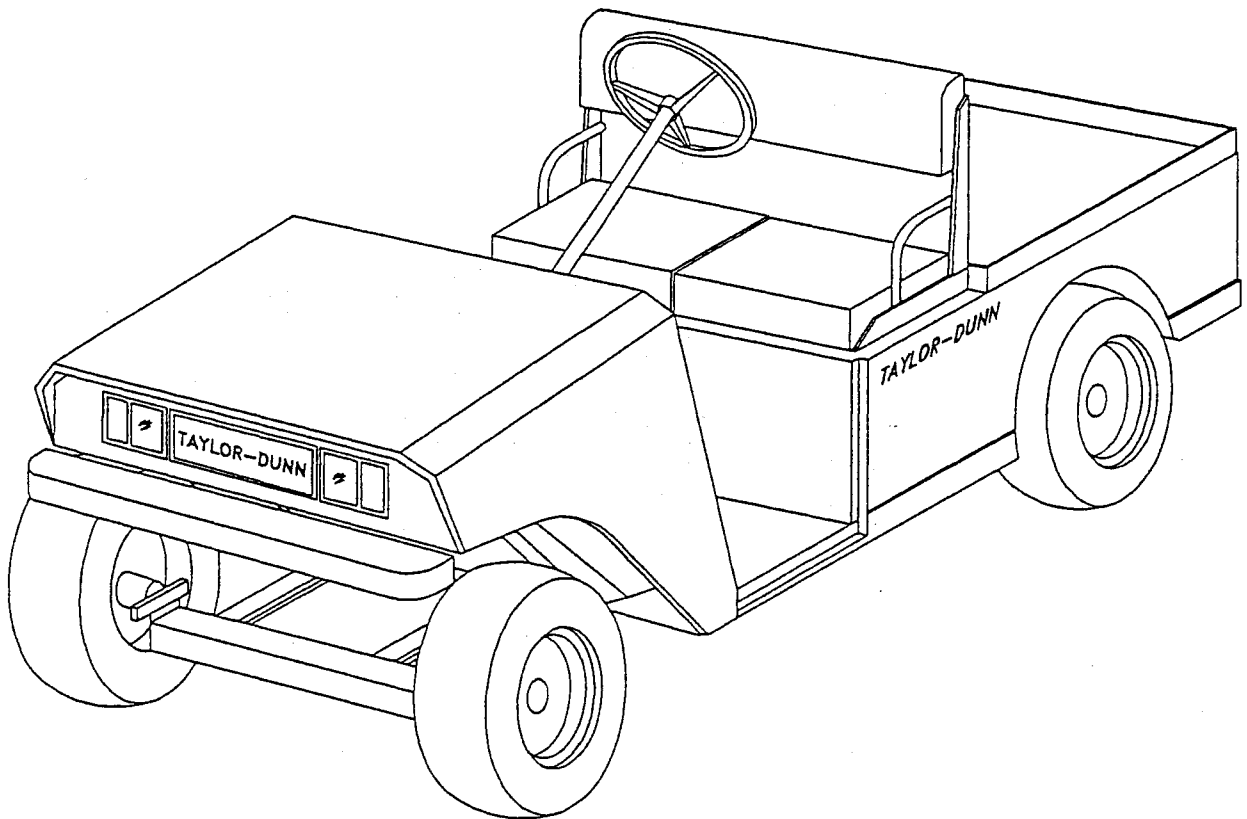

VEHICLE OPTIONS (Kits)	
PART NUMBER	DESCRIPTION
<b>BATTERIES</b>	
V2-011-16	TD-107 Battery, 220 Amp Hour, 6 @, 107 Minute
V2-011-23	230 Amp Hour Battery, 6 @, 125 Minute
V2-011-24	244 Amp Hour Battery, 6 @, 135 Minute
V2-000-04	Less Batteries
V2-011-80	TD-107 Battery, 220 Amp Hour, 6 @, Moist Charge
V2-011-89	244 Amp Hour Battery, 6 @, Moist Charge
<b>CHARGERS</b>	
R2-003-27	Lestronic II, 25A, 36V, Line Compensated, Built-In (Standard)
V2-003-19	Lestronic II, 25A, 36V, Line Compensated, Portable
R2-013-27	Lestronic II, 40A, 36V, Line Compensated, Built-In
R2-013-29	Lestronic II, 40A, 36V, Line Compensated, Portable
<b>BRAKES</b>	
R2-103-51	Mechanical Disc, Belt Type, 10.0 mph, 6.0 hp Motor, 1,150 lbs. capacity
R2-103-50	Mechanical Disc, Belt Type, 12.0 mph, 6.0 hp Motor, 1,150 lbs. capacity
R2-103-52	Mechanical Disc, Power Traction Type, 9.5 mph, 6.0 hp Motor, 1,150 lbs. capacity
R2-103-31	Hydraulic Disc, Belt Type, 10.0 mph, 6.0 hp Motor, 1,150 lbs. capacity
R2-103-32	Hydraulic Disc, Power Traction Type, 9.5 mph, 6.0 hp Motor, 1,150 lbs. capacity
R2-103-48	Mechanical Disc, Power Traction Type, 12.0 mph, 6.0 hp Motor, 1,150 lbs. capacity
<b>PAINT COLOR</b>	
V2-004-01	Safety Orange (Standard)
V2-004-02	Traffic Yellow
V2-004-04	Taylor-Green
V2-004-03	Azure Blue (Per Unit)
V2-004-08	White (Per Unit)
KV-P00-00	Paint, Special Color (Per Unit)
V2-004-30	Undercoating (Per Unit)
<b>SEAT COLOR</b>	
R3-141-00	Black Seats, 2-Passenger
XX-XXX-XX	Special Color (Per Unit)
R3-114-00	Black Seats, 4-Passenger, Requires BED TYPE R4-106-13
V2-105-33	Seat Belts, Front, 2-Passenger
V2-105-24	Seat Belts, 2nd Seat, 2-Passenger, Requires BED TYPE R4-106-13

71-102-10 *Seat Switch*

<b>VEHICLE OPTIONS (Kits)</b>	
<b>PART NUMBER</b>	<b>DESCRIPTION</b>
<b>TIRES / WHEELS</b>	
V2-007-01	5.70 x 8 Pneumatic Load Range B, Highway Tread
V2-017-51	18 x 8.50 x 8 Terra Tire, Pneumatic
V2-007-84	5.00 x 8, Soft Solid Tires, on Split Rims
V2-007-40	5.70 x 8 Pneumatic Load Range B, Highway Tread, on Split Rims
V2-007-99	Flat Out Tire Treatment (Requires Tire Option from this Table)
V2-057-00	Chrome Wheel Covers for Drop Center Wheel
V2-057-40	Chrome Wheel Covers for Split Rim Wheel
V2-057-50	Chrome Wheel Covers for 8.50 x 8 Wheel
<b>FRAME TYPE</b>	
R4-104-30	2-Passenger, Bed Size 42 1/8" Wide x 32" Long
R4-104-16	Steel Cab, Safety Glass Front and Rear Windows on Above Frame. See "Options and Accessories" for Doors
<b>BED TYPE</b>	
R4-106-11	Flat Bed, Metal Deck, with Bed Rails
R4-106-12	9" High Pipe Side Rails, Permanently Installed. (See R3-106-20, "Options and Accessories")
R4-106-65	Metal Sides, Solid, 9" High, Bolt-on with Drop Tailgate
R4-106-13	Rear Flip-up Seat for 4 Passengers, with Arm Rests Serving as Hand Rails or Side Cargo Retainers, with Seat in Fold-down Position. (See R3-106-20, "Options and Accessories")
R4-106-35	Steel Panel Box, 24" High x 43 1/2" Wide x 31" Long, with Double Locking Doors in Rear. N/A with Bed Type R4-106-12 or R4-106-13.
R4-106-55	Steel Panel Box, 45 3/8" High x 43 1/2" Wide x 31" Long, with Double Locking Doors in Rear, with Safety Glass Windows Front and Rear. N/A with Bed Type R4-106-12 or R4-106-13.
<b>SPEED CONTROL</b>	
R3-005-50	Controller, 36V, 204-00
V2-005-99	Key Lock, Keyed Unalike
<b>BUMPERS</b>	
R3-118-05	Less Bumpers (Standard)
R3-118-00	Front Bumper
R3-118-20	Front Bumper with Splash Pan
<b>FRONT AXLES</b>	
R4-108-06	Front Axle (Standard)
R4-108-16	Front Axle with Hydraulic Disc Brakes. Requires Hydraulic Option from "BRAKES".

<b>VEHICLE OPTIONS (Kits)</b>	
<b>PART NUMBER</b>	<b>DESCRIPTION</b>
<b>HEAD AND TAILLIGHTS</b>	
R2-105-40	Front Panel without Headlights and Taillights. Dual Stoplights Standard
R2-105-41	Dual Headlights and Taillights. Dual Stoplights Standard
<b>OPTIONS AND ACCESSORIES</b>	
R2-105-15	Directional Signals. Requires Headlight Option from "HEAD AND TAILLIGHTS"
V2-105-20	Motion Beeper
V2-105-21	Reverse Warning Alarm
R2-105-30	Windshield Wiper, Electric (Requires Cab Option from "FRAME TYPE")
R2-105-10	Hour Meter
V2-105-35	Strobelight, Amber on Top of Cab (Requires Cab Option from "FRAME TYPE")
R2-105-25	Strobelight, Amber, on Pole Behind Seat, N/A with Cab
R4-104-52	Doors, Metal Slam, with Locks and Safety Glass Windows, Removable (Requires FRAME TYPE R4-104-16)
R4-104-51	Doors, Naugahyde, with Plastic Windows, Removable (Requires FRAME TYPE R4-104-16)
R3-106-20	9" High Removable End Gate (Requires BED TYPE R4-104-12 or R4-104-13)
R3-106-90	Surrey Top, White, over Tubular Top Frame (N/A with BED TYPE R4-106-35 or R4-106-55)
R3-106-10	Rear Tool Box, Encloses Rear Section of Frame, Under Deck to a Tool Enclosure with Lockable Door (N/A with BED TYPE R4-106-13, N/A with OPTION R2-108-21)
R2-105-50	Mirror, Left Side View (N/A with OPTION R3-106-90)
R2-105-51	Mirror, Right Side View (N/A with OPTION R3-106-90)
V2-008-35	Mirror, Center, Inside Cab Mount
R3-106-25	Shock Absorbers, Rear Axle, 2 @, Bolt-on
R2-105-35	Windshield, Rigid Plexiglass, Clear
R2-108-21	Pintle Hitch with Mounting Bracket
V2-007-52	Hitch
V2-007-53	Hitch
V9-005-00	Decal "SECURITY" ON Cab, 2 @ ( Requires FRAME TYPE R4-104-16)
<b>PACKAGING</b>	
<b>(Wood Crate Is Required For Vehicles Weighing Less Than 1,300 lbs)</b>	
V9-000-00	Shrink Wrap Packaging without Top or Windshield (Required)
V9-000-03	Shrink Wrap Packaging with Top or Windshield (Required)
V9-001-04	Wood Crate Packaging without Cab
V9-001-03	Wood Crate Packaging with Cab
V9-001-05	Export, Container (For Container Load)
V9-001-07	Export, Wood Crate (For Less Than Container Load)