

The Best Way  
To Go  
About Your  
Business

**TAYLOR-DUNN<sup>®</sup>**



*Models:*

*SS5-34 serial number starting 94506*

*SS5-36 serial number starting 90400*

*SS5-46 serial number starting 161403*

*MX6-00 serial number starting 113227*

**MANUAL MS-534-08**

Operation, Troubleshooting  
Manual



# Operator and Maintenance Manual

---

*A guide to the operation and maintenance of Taylor-Dunn®  
Vehicles*

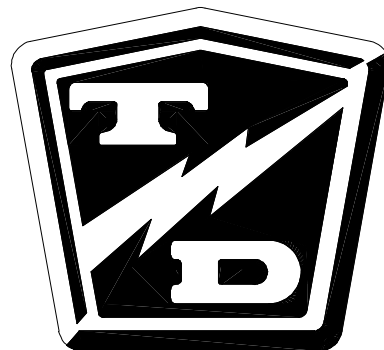

### COPYRIGHT NOTICE

Copyright © 2001 by Taylor-Dunn® Mfg. All rights reserved.

No part of this work may be reproduced or transmitted in any form or by any means, electronic or mechanical, including photocopying and recording, or any information storage or retrieval system without prior written permission of Taylor-Dunn® Mfg. unless such copying is expressly permitted by federal copyright law. Address inquiries to Reference Permissions, Taylor-Dunn® Mfg., 2114 W. Ball Road, Anaheim, CA 92804



### TAYLOR-DUNN SERVICE CENTER

For more information about this and other Taylor-Dunn® manuals, please write Taylor-Dunn®:

**Taylor-Dunn® Mfg.  
2114 W. Ball Road  
Anaheim, CA 92804  
(Attn: Technical Writer)**



## Table of Contents

---

<b>Introduction .....</b>	<b>1</b>
Who Should Read This Manual .....	2
Responsibilities .....	2
How To Use This Manual .....	3
Conventions .....	4
<b>Vehicle Description and Specifications .....</b>	<b>1-1</b>
<b>Vehicle Description .....</b>	<b>1-2</b>
Standard Specifications .....	1-3
Taking Delivery of Your Vehicle .....	1-4
What To Do If You Find a Problem .....	1-4
<b>Safety Rules and Operational Information .....</b>	<b>2-1</b>
<b>Safety Rules and Guidelines .....</b>	<b>2-2</b>
Responsibilities .....	2-2
Safety Rules .....	2-3
Driver Training Program Guidelines .....	2-4
Driver Qualifications .....	2-4
Who is Qualified to Drive? .....	2-4
Minimum Requirements .....	2-4
<b>Vehicle Controls .....</b>	<b>2-5</b>
<b>Guidlines for Vehicle Operation .....</b>	<b>2-7</b>
Driving .....	2-7
Loading and Unloading .....	2-7
Parking .....	2-7
Towing .....	2-8
<b>Maintenance and Service Procedures .....</b>	<b>3-1</b>
Maintenance Guidelines .....	3-2
Maintenance Guidelines for Vehicles Used in Severe Conditions .....	3-3
<b>Periodic Maintenance Table .....</b>	<b>3-4</b>
<b>Lubrication .....</b>	<b>3-5</b>
<b>Trouble shooting Guide .....</b>	<b>3-6</b>
<b>Brakes .....</b>	<b>3-9</b>
Adjusting the Brake Band .....	3-10
SS5-34 Brake System .....	3-10
Adjusting the Brake Cable .....	3-11
Removing the Brake Assembly .....	3-12
SS5-36, SS5-46 and MX-600 Brake System .....	3-13
Adjusting the Brake Pedal Linkage .....	3-13
Inspecting and Replacing the Park Brake Lock (All Models) Replacement and Wear of Park Brake Lock (All Models) .....	3-14 3-15
SS5-36, SS5-46 and MX-600 Rear Brakes .....	3-16
Replacing the Brake Drum .....	3-17
Replacing the Brake Shoes .....	3-18

## INTRODUCTION

<b>Front Fork and Steering .....</b>	<b>3-20</b>
Front Fork .....	3-21
Removing the Front Fork .....	3-22
Removing the Front Springs .....	3-23
Removing the Front Axle .....	3-23
Replacing the Front Wheel Bearings .....	3-24
Replacing and Adjusting the Front Fork Collar Bearing .....	3-24
Optional Geared Steering .....	3-25
SS5-34 Geared Steering Assembly .....	3-25
SS5-36, SS5-46 and MX-600 Geared Steering Assembly .....	3-27
SS5-46 Front Axle and Steering .....	3-28
Replacing the Front Wheel Bearings .....	3-28
Removing the Front Axle Assembly .....	3-29
Aligning the Front Wheels .....	3-29
Replace the King Pin or Bushings .....	3-29
<b>Rear Axle and Drive Assembly .....</b>	<b>3-30</b>
Removing the SS5-34 Rear End Assembly .....	3-31
Removing the SS5-36 and SS5-46 Rear End Assembly .....	3-32
Removing the MX-600 Rear End Assembly .....	3-33
Differential and Rear Axle .....	3-34
SS5-34 Drive Service .....	3-35
Disassembly of the Belt Drive Assembly .....	3-35
Removing and Servicing the Rear Axle ..	3-36
Differential Service and Repair .....	3-37
Motor Removal .....	3-40
Changing the Differential Oil .....	3-40
Adjusting Belt Tension .....	3-41
Aligning Pulleys .....	3-42
SS5-36, SS5-46 and MX-600 Drive Service .....	3-43
SS5-36/SS5-46/MX-600 Removing and Servicing the Rear Axle .....	3-43
Servicing the Differential .....	3-44
<b>Motor .....</b>	<b>3-47</b>
SS5-36/SS5-46/MX-600 Motor Removal .....	3-47
SS5-34 Motor Removal .....	3-48
Brushes .....	3-48
Installing New Brushes .....	3-49
Motor Disassembly .....	3-49
Inspecting the Armature .....	3-50
<b>Battery .....</b>	<b>3-51</b>
Cleaning .....	3-51
Servicing the Batteries .....	3-52
Charging .....	3-52
Battery Storage .....	3-52
Battery Configuration .....	3-53

<b>SECTION 4-Electrical Troubleshooting .....</b>	<b>1</b>
Test Equipment Required: .....	3
<b>IMPORTANT NOTES and INSTRUCTIONS .....</b>	<b>3</b>
Definitions: .....	4
<b>Section 4a-Vehicle Wire Diagrams .....</b>	<b>1</b>
Model MX 6-00 .....	2
Model SS 5-34, SS5-46 and SS 5-36 with the Dual Chassis Harness .....	3
Model SS 5-34 with the Single Chassis Harness .....	4
<b>Section 4-Special Troubleshooting Guide .....</b>	<b>1</b>
PMC CONTROL .....	2
PLUGGING DIODE .....	4
FREEWHEEL DIODE .....	5
ISO .....	6
SOLENOIDS .....	8
MOTOR .....	11
<b>SECTION 4b-Lestronic II Charger Troubleshooting .....</b>	<b>1</b>
Operating Instructions and Theory of Operation .....	2
Testing the Charging Cycle .....	3
Test Equipment Required for Troubleshooting .....	4
Important Notes and Instructions .....	4
Troubleshooting for Built-in Charger .....	5
Troubleshooting for Portable Charger .....	8
Testing The Timer Relay .....	9
Testing the Interlock Relay .....	10
<b>SECTION 4c-Signet Charger Troubleshooting .....</b>	<b>1</b>
Operating Instructions and Theory of Operation .....	2
Testing the Charging Cycle .....	3
Test Equipment Required for Troubleshooting .....	4
Status LED Error Code .....	5
Troubleshooting .....	6

TABLE OF CONTENTS

**Illustrated Parts List ..... 5-1**

IDENTIFYING YOUR VEHICLE ..... 5-2

BRAKE PEDAL LINKAGE AND ACCELERATOR PEDAL (SS5-34) .... 5-4

BRAKE PEDAL LINKAGE (SS5-36, SS5-46 AND MX-600) ..... 5-6

FRONT AXLE, WHEEL AND SUSPENSION ..... 5-8

FRONT AXLE, WHEEL AND STEERING (SS5-46) ..... 5-10

TILLER STEERING ..... 5-12

GEARED STEERING (SS5-34) ..... 5-14

GEARED STEERING (SS5-36, SS5-46 AND MX-600) ..... 5-16

INSTRUMENT PANEL (SS5-34, SS5-46 AND SS5-36)..... 5-18

CONTROLS AND INSTRUMENTS (MX-600) ..... 5-20

MOTOR SS5-34 ..... 5-22

MOTOR SS5-36, SS5-46 & MX-600 ..... 5-24

REAR AXLE (SS5-34) ..... 5-26

REAR AXLE (SS5-36, SS5-46 AND MX-600) ..... 5-28

DIFFERENTIAL (SS5-34)..... 5-30

DIFFERENTIAL (SS5-36, SS5-46 AND MX-600) ..... 5-32

SS5-36, SS5-46 DIFFERENTIAL FRAME..... 5-34

DECK AND VISE ASSY (MX-600) ..... 5-36

TOOLBOX ASSY (MX-600)..... 5-38

BATTERY ..... 5-40

BRAKE ASSY (SS5-34) ..... 5-42

REAR BRAKE (SS5-36, SS5-46 AND MX-600) ..... 5-44

PMC CONTROL PANEL ..... 5-46

BATTERY CHARGER ..... 5-48

REAR TIRE AND WHEEL ..... 5-50

SEAT CUSHIONS ..... 5-52

DECALS..... 5-54

MIRRORS OPTION ..... 5-56

STROBE AND STOP LIGHT OPTION ..... 5-58

HEADLIGHT ..... 5-60

PARTS APENDIX A..... 5-63

SIGNET CHARGER ..... 5-64



## Introduction

Your purchase...

The purchase of this vehicle shows a belief in high quality products manufactured in the USA. Taylor-Dunn®, a leading manufacture of electric burden and personnel carriers since 1949, wants to be sure that you get the most out of your vehicle and that it provides years of reliable service. Please continue to read this manual and enjoy your high quality Taylor-Dunn® vehicle.

This manual is to serve as a guide for the service, repair and operation of the Taylor-Dunn® vehicle, and is not intended as a training guide. Taylor-Dunn® has made every effort to include as much information as possible about the operation and maintenance of it's vehicles.

What's contained in this manual?

Included in this manual are the:

- Vehicle Description
- Safety Rules and Guidelines
- Operational Information
- Operator Responsibilities
- Owner Responsibilities
- Control Operation and Location Information
- Maintenance and Troubleshooting Information
- Parts Lists of Standard Parts

Before servicing....

Before servicing, operating, training, or performing maintenance on this or any Taylor-Dunn® vehicle, read the entire manual and note all cautions, warnings, and notes contained in this manual.

## INTRODUCTION

### Who Should Read This Manual

This manual is intended for use by anyone who is going to operate, own, perform maintenance, service, or order parts for a Taylor-Dunn® vehicle. Each person should be familiar with the parts of this manual that apply to them.

### Responsibilities

#### **Of the Owner...**

The owner of this or any Taylor-Dunn® vehicle is responsible for the training of operators, overall maintenance, and repairs of the vehicle. Owners should keep a record of conducted training and services or repairs performed on the vehicle. (OSHA Regulation, 29 CFR (Code of Federal Regulations) 1910.178 Powered Industrial Truck Operator Training.)

#### **Of the Operator...**

The operator is responsible for the safe operation of the vehicle, preoperational and operational checks on the vehicle, and reporting any problems to service and repair personnel.

#### **Of the Service Personnel...**

The service personnel are responsible for the service and maintenance of the vehicle, from lubrication to repair of damaged or worn parts. At no time should a service person allow any untrained personnel to service or repair this or any vehicle. For the purposes of training, a qualified service person may oversee the repairs or services being made to a vehicle by an individual in training. At no time should an untrained individual be allowed to service or repair a vehicle without supervision. This manual is not a training guide.



## How To Use This Manual

This manual is organized into four main sections:

- Section 1: “Safety Rules and Operational Information,” outlines the safety issues and operational issues of the vehicle. Including the location and operation of controls, the operational checks that are to be performed, and various subjects that should be included in any operator and service training programs implemented by the owner.
- Section 2: “Maintenance and Repair,” gives specific information on the maintenance and repair of the vehicle and a schedule for maintenance checks.
- Section 3: “Electrical and Charger Troubleshooting,” gives the troubleshooting procedures for testing the electrical system and battery charger.
- Section 4: “Parts,” gives an illustrated view of various assemblies and a table listing the part numbers and quantities needed.

On the next page you will find a list of conventions that are used throughout this manual. (Conventions are symbols and/or words that are used to define warnings, cautions or notes.)

## INTRODUCTION

### Conventions

Throughout this manual you will find the following notations:

#### **WARNING**

A shaded box with the word “Warning” on its left denotes a warning. A warning alerts you of a hazard that may cause injury to yourself or others. Be sure to follow any instructions contained within a warning and exercise extreme care while performing the task.

#### **CAUTION**

The symbol at the left and the bold text contained within a box denotes a caution and is used to inform you that property damage may occur. Be sure to exercise special care and follow any instructions contained within a caution.

NOTE 1: Alerts you to additional information about a subject. A number immediately after the word note is included for reference within each subject.



# Vehicle Description and Specifications

---

Describes the Vehicle and Its Standard Specifications

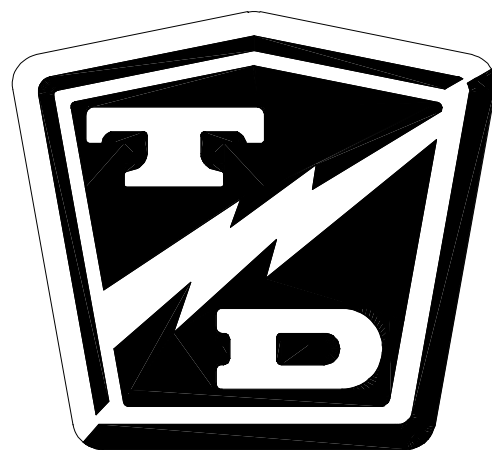

## SECTION 1

# Vehicle Description

This manual applies to vehicles with the same model and serial numbers listed on the front cover.

This vehicle is designed for driving on smooth surfaces in and around industrial plants, nurseries, institutions, motels, mobile home parks, and resorts. It is not to be driven on public highways.

The maximum operating speed of this vehicle is the speed that the vehicle may travel on a level surface with no load. Exceeding this speed, while traveling down an incline or on a level surface, may result in steering difficulty, motor damage, and/or loss of control of the vehicle that may result in injury and/or property damage. It is just as important that the vehicle not be towed faster than 5 mph.

This vehicle conforms to requirements for Type E vehicles as described in O.S.H.A. Standard Section 1910.178 (Powered Industrial Trucks) and with all applicable portions of the American National Standard for Personnel and Burden Carriers (ANSI B56.8), in effect at the time of manufacturing.

The model and serial number for this vehicle are imprinted on a decal located on the inner left side of the front cowl. The vehicle serial number is stamped in the frame, under the drivers seat to the right of the safety interlock switch on the MX-600, on the frame tube to the left of the motor on the SS5-34, and on the left frame rail under the seat on the SS5-36 and SS5-46.



**Taylor-Dunn Mfg. Standard Model SS5-34 shown. This is one of the vehicles described and covered by this manual.**



## Standard Specifications

ITEM		SPECIFICATION		
Standard Dimension	(SS5-34)	<u>Length</u>	<u>Width</u>	<u>Height</u>
		194.3 x 72.4 x 106.7 cm		
	(MX-600)	76.5 x 28.5 x 42 in		
		217.4 x 81.3 x 104.1 cm		
	(SS5-36)	86 x 32 x 41 in		
	(SS5-36)	219.7 x 76.2 x 104.1 cm		
		86.5 x 30 x 41 in		
	(SS5-46)	226.1 x 76.2 x 104.1 cm		
		89 x 30 x 41 in		
Bed Size	(MX-600)	68.6L X 76.2W cm (27L X 30W in)		
	(SS5-34)	59.7L X 69.9W cm (23.5L X 27.5W in)		
	(SS5-36, 5-46)	49.5L X 73.7 cm (19L X 30W in)		
Dry Weight (Including Batteries)	(SS5-36 & MX-600)	352 kg (775 lbs)		
	(SS5-34)	332 kg (713 lbs)		
	(SS5-46)	376 kg (830 lbs)		
Turning Radius	(MX-600)	205 cm (81 in)		
	(SS5-34 & SS5-36)	190.5 cm (75 in)		
	(SS5-46)	208.7 cm (81 in)		
Brakes	(SS5-36, 5-46, MX-600) (SS5-34)	2-Wheel Rear Drum (Mechanical Standard) Drive Line Brake Band		
Motor		24 Volts, 4.5 hp @ 935 rpm		
Tires		4.80 X 8 Load Range B Pnuematic		
Tire Pressure		50 psi max.		
Maximum Load (On Level Surface)	(MX-600, SS5-36, 5-34)	272 kg (600 lbs.)		
	(SS5-34)	227 kg (500 lbs)		
Battery		Four 217 AH, 6 Volt		
Charger		120V, 12Amp, 60Hz AC Input 24V, 25Amp DC Output		
Gradeability		15% (Empty) 5% (Loaded)		
Maximum Speed (Empty)		16 kmh (10 mph)		

## SECTION 1

### Taking Delivery of Your Vehicle

You should inspect your vehicle immediately after delivery. Use the following guidelines to inspect your vehicle for obvious problems:

- Examine the contents of all packages and accessories that may have come in separate packages with the vehicle.
- Make sure everything listed on the packing slip is there.
- Inspect all components of the packages for signs of damage.
- Examine all visible wires and the vehicle for obvious signs of damage.
- Check that all wire connections, battery cables, etc., are secure.
- Check battery cells to be sure they are filled.
- Check the tire pressure, tightness of lug nuts and for signs of obvious damage or wear.
- Check the operation of each of the following controls. They should operate smoothly without sticking or requiring undue effort:
  - Accelerator Pedal
  - Brake Pedal
  - Forward/Reverse Selector Switch
  - Battery Disconnect Switch (Optional)
  - Key-Switch
  - Parking Brake
  - Steering Wheel
  - Horn
  - Lights

### What To Do If You Find a Problem

If there is a problem with the vehicle or any of the accessories that may have been shipped with the vehicle, file a claim with the carrier immediately. The claim must be filed within 48 hours of receiving the vehicle and the accessories. Forward a copy of the claim to your local Taylor-Dunn dealer.

The only personnel authorized to repair, modify, or adjust any part of this or any Taylor-Dunn vehicle is a factory authorized service technician. All other personnel are expressly prohibited from working on, repairing, adjusting, or modifying any part of this or any Taylor-Dunn vehicle.

#### **WARNING**

**Do not attempt to modify or repair any part of this vehicle unless you are authorized to do so. Incorrect repairs may result in injury to yourself or others. Incorrect or unauthorized repairs will result in the invalidation of your warranty.**

# Safety Rules and Operational Information

Safety rules, guidelines, control functions, operating guidelines and storage information

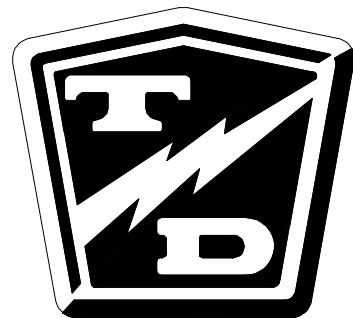

## SECTION 2

# Safety Rules and Guidelines

## Responsibilities

It is the responsibility of the owner to ensure that the operator understands the various controls and safety operations of this vehicle, as well as, obeying the following safety rules and guidelines:

### **⚠ WARNING**

**This vehicle was not designed to be driven on public highways. The size, speed, and maneuverability of this vehicle would cause a serious traffic hazard on a public highway. Driving this vehicle on public highways can result in serious injury or even death.**

### **⚠ CAUTION**

**This vehicle may overturn if turned sharply while driving at high speeds on inclines or level surfaces.**

---

### Safety Rules

This vehicle is designed to be driven over smooth surfaces in and around places such as warehouses, nurseries, motels, parks, and resorts. Operators should read the safety rules, and guidelines below before operating this vehicle:

- Do not drive this vehicle unless you are a qualified operator.
- Keep all body parts inside the vehicle at all times.
- Drive slowly when making turns, especially if the ground is wet, slippery, or when driving on an incline.
- Drive only on level surfaces or on inclines of no more than 10% (5.6 degrees).
- Do not drive over loose objects, holes, or bumps.
- Observe all traffic regulations and speed limits.
- Maintain a safe distance from all objects.
- Keep the vehicle under control at all times.
- Yield the right of way to pedestrians and all emergency vehicles.
- Do not overtake or attempt to pass another vehicle at intersections, blind spots, or other dangerous locations.
- Keep a clear view ahead at all times.

## SECTION 2

### Driver Training Program Guidelines

The owner of this vehicle is responsible for conducting an “Operator Training Program” for all those personnel that will be operating this vehicle. The program should not be condensed for those claiming to have previous vehicle operation experience.

NOTE: Successful completion of the “Operator Training Program” should be required for all personnel that will operate this vehicle.

The “Operator Training Program” should include the following:

- Operation of the vehicle under normal circumstances. (Associated with your particular environment.)
- How to safely operate the vehicle.
- How to safely transport cargo and personnel.
- All safety rules contained in this manual.
- Proper operation of vehicle controls.
- Operator maintenance checks.
- A test on the operators ability to identify and operate the controls installed on this vehicle.
- A driving test.

### Driver Qualifications

---

#### Who is Qualified to Drive?

A qualified driver is a person who has successfully completed the owners “Operator Training Program” and has shown through testing to possess the visual, auditory, physical, and mental abilities to safely operate this vehicle.

---

#### Minimum Requirements

The following are the minimum requirements necessary to qualify as an operator of this vehicle:

- Demonstrate a working knowledge of each control
- Understand all safety rules and guidelines as presented in this manual
- Know how to load and unload cargo
- Know how to properly park this vehicle
- Demonstrate the ability to handle this vehicle in all conditions





## Vehicle Controls

The following text describes the use and location of each of the controls available on this vehicle:

---

### Key-Switch

---

For the SS5-36, 5-46 and SS5-34 the key-switch, located on the right side of the instrument panel, turns on the vehicle. On the MX-600, the key switch is located on the instrument panel to the right of the seat. Rotate the key clockwise to turn the vehicle on, counterclockwise to turn the vehicle off.

The key-switch should be in the off position whenever the operator leaves the driver's seat. This switch is also designed to secure and disable the vehicle. You can remove the key **ONLY** when the key-switch is in the OFF position.

---

### Forward/Reverse Lever

---

The forward-reverse rocker switch is located on the dash on the SS5-34, 5-36 and 5-46 and on the panel to the right of the seat on the MX-600. It determines the direction of travel of the vehicle. Push the top of the switch to make the vehicle go forward. Push the bottom of the switch to go in reverse. **DO NOT SHIFT** from forward to reverse or vice-versa while the vehicle is in motion. Make sure the vehicle is completely stopped before shifting. The forward-reverse switch has a neutral position. The switch should be in the neutral position with the park brake set whenever the operator leaves the driver's seat.

---

### Accelerator Pedal

---

The accelerator pedal is located to the right of the brake pedal. It controls the speed of the vehicle, is designed for right foot operation only and operates the same way as the accelerator pedal in an automobile. Depress the pedal to speed the vehicle up. Release the pedal to slow down.

---

### Seat Interlock Switch

---

A switch located under the driver's seat disables the vehicle when the driver leaves the seat. The driver must be seated for the vehicle to operate.

The seat switch is optional on the SS5-34.

## SECTION 2

---

### Foot Brake Pedal

---

The foot brake pedal located to the left of the accelerator pedal and is for operation with the right foot only. It works the same as the brake in an automobile. Applying pressure to the brake pedal slows the vehicle according to the amount of pressure applied. Removing your foot from the pedal releases the braking action.

---

### Steering

---

The standard steering system is a loop tiller type. To turn right, turn the tiller to the left. To turn left, turn the tiller to the right .

Optional steering wheel - The steering wheel and steering system are similar to an automobile. To turn right, turn the steering wheel clockwise. To turn left, turn the steering wheel counter-clockwise.

---

### Park Brake

---

The parking brake is part of the foot brake pedal. To set the parking brake, push down on the lower half of the brake pedal until the pedal locks in the down position. To release the park brake, apply pressure on the upper half of the brake pedal until the pedal disengages from the locked position.

---

### Horn Button

---

The horn button is located on the left side of the floor board and is designed for left foot operation. Depress the button to sound the horn, release it to turn it off.

---

### Headlights and Accessories (Optional)

---

The headlight switch is located of the left side of the instrument panel. An accessory switch, if any, is adjacent and to the right of it. On the MX-600 these switches are located on the instrument panel to the right of the seat.

---

### Hour Meter (optional)

---

The hour meter is located to the right of the battery status indicator. This tracks the number of hours the vehicle has been in operation. On the MX-600, it is located on the kick panel just to the right of the seat.

---

### Battery Status Indicator

---

The battery status indicator is located to the right of the accessory switch. The normal operating range is in the green zone. The vehicle needs charging if it is in the yellow zone to the left. If it is in the red zone to the left, the vehicle should be taken out of service immediately to be charged. On the MX-600 it is located on the kick panel just to the right of the seat.



## Guidelines for Vehicle Operation

The following text contains the guidelines for driving, loading, unloading, parking, and towing the vehicle:

### Driving

- Slow down and sound the horn when approaching a corner or a blind intersection.
- There is no horseplay or dangerous driving allowed while operating the vehicle.
- Do not drive this vehicle in hazardous areas, unless this vehicle is approved and labeled for such operation.
- Report any accidents or vehicle problems to your supervisor immediately.

### Loading and Unloading

- Do not load cargo that can easily fall off this vehicle.
- Do not exceed the load capacity of this vehicle.
- Do not carry more than the maximum number of passengers allowed for this vehicle.
- Be extra careful when handling cargo that is longer, higher, or wider than the vehicle.

### Parking

- Park the vehicle by turning the key-switch off, placing the forward/reverse lever in neutral, and setting the park brake.
- If parking on an incline, block the wheels to prevent movement.
- Do not block fire aisles, emergency equipment, or stairways.

## SECTION 2

### Towing

- Attach the tow strap to the front bumper tow-bar and place the forward/reverse switch in neutral.
- Use another driver to steer and control the speed of the vehicle, while it is being towed.
- The driver of the towed vehicle is to maintain a safe distance from the towing vehicle and use the brakes when the towing vehicle slows or stops.
- Do not exceed 5 mph or carry any passengers while towing the vehicle.

NOTE: This vehicle is not to be towed using a commercial tow truck. It may be towed either behind another vehicle of the same type or on a flat bed tow vehicle.

### **⚠ WARNING**

**Exceeding the towing speed limit or carrying passengers can result in damage to the vehicle and serious injury. At no time are passengers allowed in the towed vehicle. The only personnel allowed to ride in the towed vehicle is the operator/driver.**

**All cargo must be removed from the vehicle prior to towing.**

# Maintenance and Service Procedures

Maintenance and Service Information, Including Lubrication  
Information, Scheduled Maintenance, and Disassembly

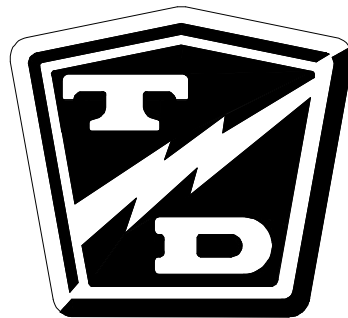

## SECTION 3

### Introduction to Maintenance

This section contains the procedures necessary to repair and service your vehicle. You will also find periodic maintenance information and guidelines to follow before doing any kind of maintenance or service on this vehicle. Vehicle maintenance or repairs should only be performed by a qualified mechanic.

This section contains the following:

- Maintenance Guidelines
- Maintenance Guidelines for Vehicles Used in Severe Conditions
- Maintenance Checklist
- Lubrication Chart
- Troubleshooting Guide
- Detailed Maintenance Procedures.

### Maintenance Guidelines

- Allow only qualified and authorized personnel are to maintain, repair, adjust, and inspect the vehicle.
- Before starting any repairs or maintenance, immobilize the vehicle by turning the key switch off, removing the key, and setting the park brake.
- Disconnect both of the main battery leads before working on or disconnecting any electrical component or wire.
- Block the chassis with jack stands before working under a raised vehicle.
- Conduct vehicle performance checks in an authorized area where safe clearance exists.
- Before starting the vehicle, follow the recommended safety procedures in Section 2, “Safety Rules and Operational Information.”
- Avoid fire hazards and have fire protection equipment present in the work area. Do not use an open flame to check level or leakage of battery electrolyte. Do not use open pans of fuel or flammable fluids for cleaning parts.
- Ventilate the work area properly.
- Regularly inspect and maintain in a safe working condition, brakes, steering mechanisms, speed and directional control mechanisms, warning devices, lights, governors, guards, and safety devices.



- Inspect and maintain battery limit switches, protective devices, electrical conductors, and connections in conformance with Taylor-Dunn's recommended procedures.
- Keep the vehicle in clean condition to minimize fire hazards and facilitate detection of loose or defective parts.

## **⚠ WARNING**

**Periodic maintenance and service must be performed on this vehicle. Failure to complete these scheduled maintenance and service procedures can result in personal injury, and/or property damage. It is the owner and/or operators responsibility to insure that proper service and maintenance is performed on the vehicle, described in this manual.**

## Maintenance Guidelines for Vehicles Used in Severe Conditions

The following list is meant as a guide and is not all inclusive:

### **SEVERE CONDITIONS refer to operation:**

- In extreme temperatures
- On bumpy, dusty, or ill maintained roads
- In excessively wet areas
- In corrosive or contaminated areas
- At or near maximum capacity for more than 50% of the operating time
- On multiple shifts

### **Severe Duty Maintenance Guidelines:**

If this vehicle is operate in severe conditions all maintenance items listed in the Periodic Maintenance Table should be carried out twice as often as stated. In addition, the whole vehicle should be inspected monthly for signs of damage and repaired immediately.

## SECTION 3

## Periodic Maintenance Table

Periodic Maintenance Checklist					
Maintenance Item	Weekly (20hrs)	Monthly (80hrs)	Quarterly (250hrs)	Semi - Annual (500hrs)	Annualy (1000hrs)
Check Condition of Tires	<b>X</b>				
Check and Fill Batteries	<b>X</b>				
Check Brake System		<b>X</b>			
Check Steering System		<b>X</b>			
Lubricate Vehicle			<b>X</b>		
Clean and Tighten All Wire Connections			<b>X</b>		
Wash and Service Batteries			<b>X</b>		
Check Park Brake				<b>X</b>	
Check Front Wheel Bearings				<b>X</b>	
Check Rear Axle Oil				<b>X</b>	
Change Rear Axle Oil					<b>X</b>
Check and Tighten all Nuts and Bolts					<b>X</b>
Clean and Repack Front Wheel Bearings					<b>X</b>



### Lubrication

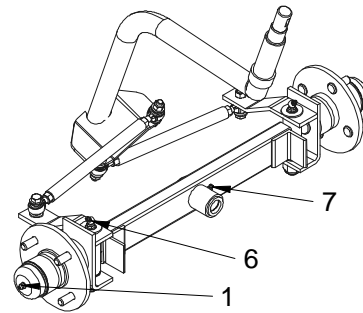
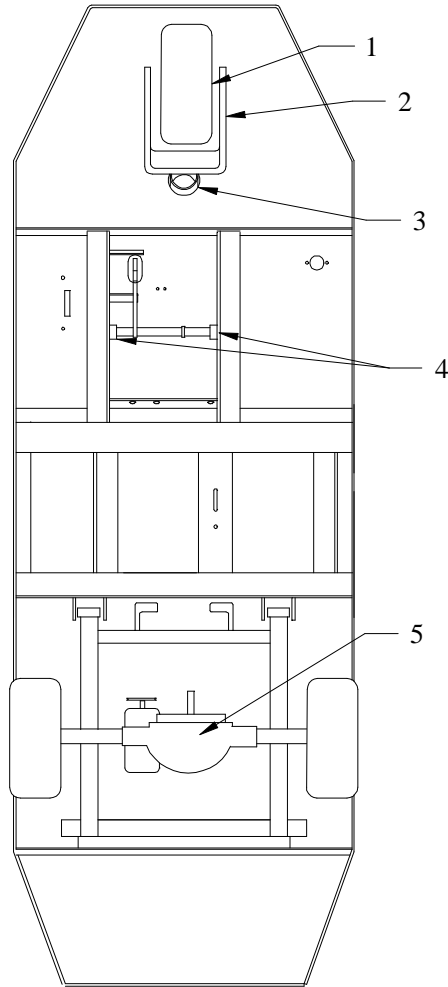

**SS5-46 Front Axle**

#	Description	Locations	Lubricant
1	Front Wheel Bearing	1	High Temp Wheel Bearing Grease
2	Front Fork Pivots	2	General Purpose Grease
3	Steering Collars	1	General Purpose Grease
4	Brake Shaft Collars	2	General Purpose Grease
5	Rear Axle Differential	1	SS-536, SS 5-46, MX-600, SAE 30 Motor Oil SS5-34, SAE 140 API GL-5 Gear Oil
6	King Pin (SS5-46)	2	General Purpose Grease

## SECTION 3

### Trouble shooting Guide

Symptom	Probable Cause
Steering Pulls in One Direction	Worn Wheel or Collar Bearing Low Tire Pressure Broken or Missing Spring Bent Frame or Fork
Hard Steering	Dry Lube Points in Steering Linkage Low Tire Pressure
Lack of Power or Slow Operation	Brakes or Parking Brake Dragging Worn Drive Gears or Bearings Loose or Worn Drive Belt Low Battery Defective Speed Controller Defective or Worn Motor Brushes
Abnormal Noise	Worn Drive Gears or Bearings Loose or Worn Drive Belt Worn Front/Rear Axle Bearings Loose Lug Nuts Motor Bearings Worn
Oil Leak in Rear Bearing Area	Rear Wheel Bearing and/or Gasket Failed Drive Over Filled
No Brakes	Brakes out of Adjustment Brake Pedal Linkage Binding or Broken
Brake Pedal Low	Brake Worn (1/16-inch Wear Limit) Brakes Out of Adjustment
Braking Power Low	Brake Worn (1/16-inch Wear Limit) Brakes Out of Adjustment Brake Pedal Linkage Binding



NOTES

SECTION 3

**MECHANICAL REAR DRUM BRAKES  
(STANDARD ON SS5-36, SS5-46 & MX-600)**

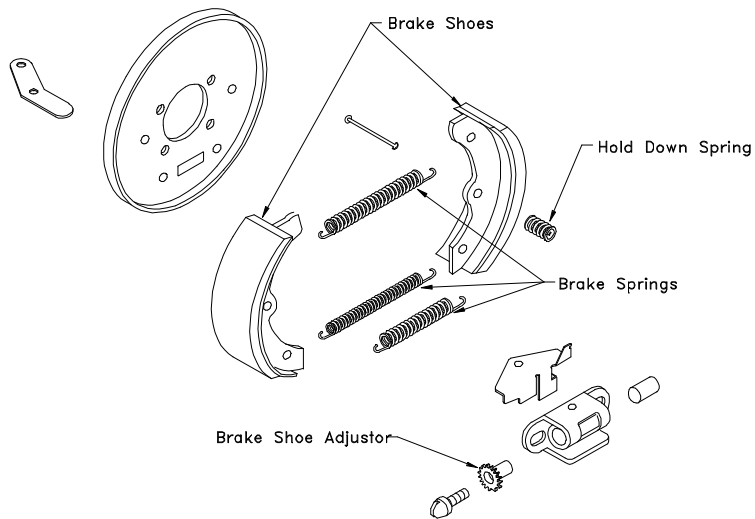

**DRIVE LINE BRAKE BAND (STANDARD  
ON SS5-34)**

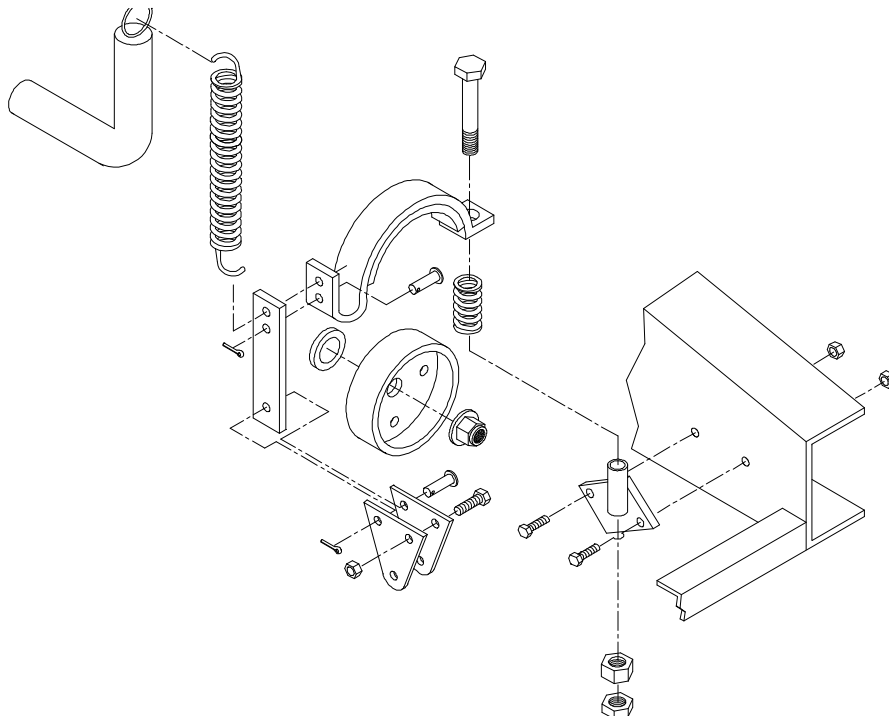

## Brakes

This section covers the installation and repair of the brake systems that are installed on the SS5-34, SS5-36, SS5-46 and MX-600. These vehicles come equipped either with the mechanical rear drum brakes (found on the SS5-36, SS5-46 & MX-600) or the drive line brake band (found on the SS5-34).

Be fully aware of the brake system installed on the vehicle before continuing.

### **▲ WARNING**

**The OEM does not supply asbestos fiber-brake pads/shoes with this or any vehicle. However, there is the possibility that the OEM brake pads/shoes were replaced with those containing asbestos fibers. Since this possibility does exist the brake pads should be handled as if they do contain asbestos.**

**Never use compressed air or dry brush to clean brake assemblies. Use an OSHA approved vacuum cleaner or any alternate method approved by OSHA to minimize the hazard caused by airborne asbestos fibers and brake dust.**

**Do not grind, sand, break, or chisel the brake pads/shoes as this will cause unnecessary dust possibly releasing asbestos fibers into the air.**

**Always wear a respirator, protective clothing and a face shield when working on the brake system.**

**Inhaled asbestos fibers have been found to cause cancer and respiratory diseases.**

**Do not drive the vehicle if any worn or broken part is detected in any part of the brake system. The cause of the damage must be repaired immediately.**

NOTE: The park brake system is similar regardless of the brake system installed in the vehicle.

NOTE: To apply the park brake, apply pressure to the lower half of the foot pedal until it locks in place. To release the park brake apply pressure to the upper half of the pedal.

## SECTION 3

# SS5-34 Brake System

The SS5-34 comes standard with a mechanical drive line brake. The brake drum is attached to the pinion shaft. The brake band is anchored to the frame of the vehicle and attached to the brake pedal by the brake lever arm.

Here we will cover how to remove and service the mechanical drive line brake system. Refer to the illustration in the beginning of this section

### **⚠ WARNING**

**There are springs attached to parts of this braking system. There is a possibility that these springs may break or slip out of their mounting holes while servicing the brake. To prevent possible injury to the head or face a face shield should be worn whenever you are working on or around the brake band.**

## Adjusting the Brake Band

The brake band may need to be adjusted periodically to compensate for the normal wear of the brake lining or pad on the band. To adjust the brake band, do the following:

1. Park the vehicle in a clean, flat area and remove the key.
2. Block the tires to prevent the vehicle from accidentally moving.
3. Lift and secure the deck.
4. Tighten the brake band anchor bolt until brake pad engages the drum with sufficient force to stop the vehicle when the brake pedal is halfway down to the floor board.

**NOTE:** With this adjustment, the parking brake is automatically adjusted, so that when the lower slot of the pedal engages the locking angle welded to the frame proper braking force is applied. As the lining wears, the pedal travel will increase to the point where the upper slot must engage the locking angle to provide adequate braking force. The brake band must be adjusted before lining wear reaches the point where engagement in the upper slot fails to provide adequate braking force.

## Adjusting the Brake Cable

The brake cable length must be adjusted so that the brake lever arm (located below the brake drum) is pivoted rearward as far as possible.

To adjust the brake pedal linkage:

1. Park the vehicle on a clean level surface and block the rear wheels to prevent movement.
2. Raise the front of the vehicle and support it with jack stands.

### **WARNING**

**Always use a lifting strap, hoist and jack stands of adequate capacity to lift and support the vehicle. Failure to use lifting and supporting devices of rated load capacity to support the vehicle may result in serious injury and property damage.**

3. Loosen the jam nut on the brake cable.
4. Tighten the adjusting bolt until the brake cable is slightly tight.  
**NOTE:** There should be some slack in the brake cable. Do not overtighten the brake cables. Overtightening of the adjusting nut and the cables will result in brake drag and premature failure of the brake shoes.
5. Tighten the jam nut against the clevis and lower the vehicle.
6. Check the brake pedal to see that the park brake lock engages with medium pressure on the lower half of the pedal.
7. Release the park brake and test drive the vehicle checking for brake drag.
8. Check the travel of the brake pedal. It should have about 1/2" of travel before it engages the brakes.

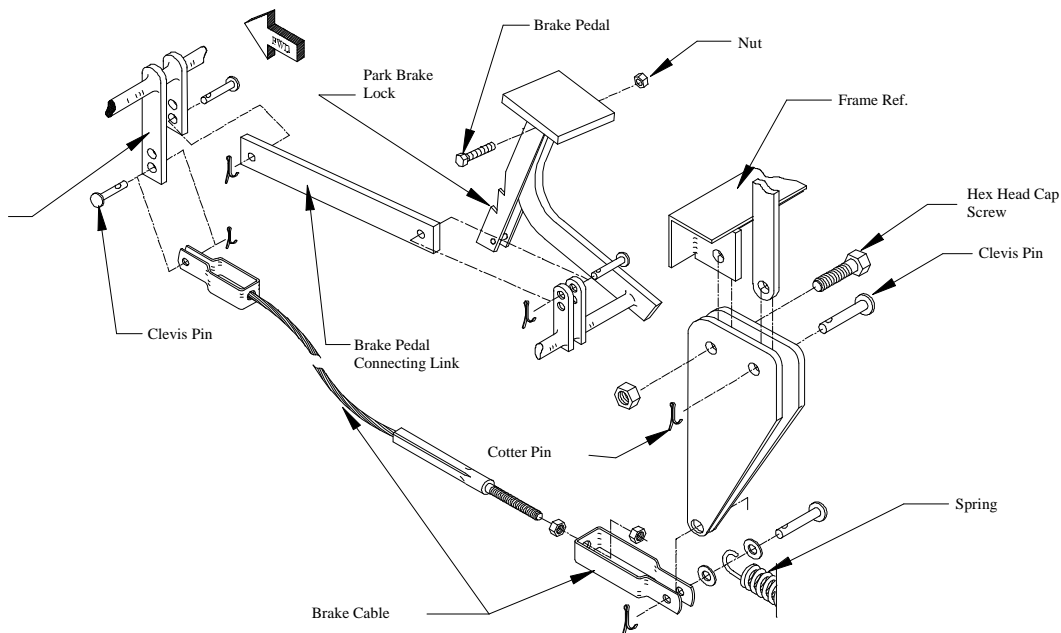

## SECTION 3

### Removing the Brake Assembly

In order to remove the brake assembly refer to the following instructions:

1. Park the vehicle on a level surface and block the tires to prevent any accidental movement.
2. Remove the key and place the forward/reverse switch in the neutral position.
3. Remove the deck board and seat from the vehicle.
4. Remove the spring from the lever bar.
5. Remove the cotter pin and the clevis pin from the brake band.
6. Remove the brake band anchor bolt and brake band.
7. Remove the brake drum from the pinion shaft.
8. Clean and inspect the brake band and brake drum. Replace all worn parts as needed.

NOTE: If the brake lining or pad is 1/16" or less in thickness, the lining must be replaced. Also, if the brake drum is severely scored, damaged, or less than 5.85" in diameter it must be replaced with a new brake drum.

NOTE: If the brake drum is glazed or lightly scored. The glazing or scoring should be removed from the drum by sanding.

9. Reinstall the brake assembly by doing steps 1 through 7 in reverse order.
10. Adjust the brake band.





## SS5-36, SS5-46 and MX-600 Brake System

### Adjusting the Brake Pedal Linkage

To adjust the brake pedal linkage, refer to the following procedures.

1. Park the vehicle on a clean level surface and block the rear wheels to prevent movement.
2. Raise the front of the vehicle and support it with jack stands.
3. Loosen the jam nut on the brake linkage.

#### **⚠ WARNING**

**Always use a lifting strap, hoist and jack stands of adequate capacity to lift and support the vehicle. Failure to use lifting and supporting devices of rated load capacity to support the vehicle may result in serious injury and property damage.**

4. Tighten the adjusting bolt until the brake cables are slightly tight.  
NOTE: There should be some slack in the brake cables. Do not overtighten the brake cables. Overtightening of the adjusting bolt and the cables will result in brake drag and premature failure of the brake shoes.
5. Tighten the jam nut against the clevis and lower the vehicle.
6. Check the brake pedal to see that the park brake lock engages with medium pressure on the lower half of the pedal.
7. Release the park brake and test drive the vehicle checking for brake drag.
8. Check the travel of the brake pedal. It should have about 1/2" of travel before it engages the brakes.

SECTION 3

Inspecting and Replacing the Park Brake Lock(All Models)

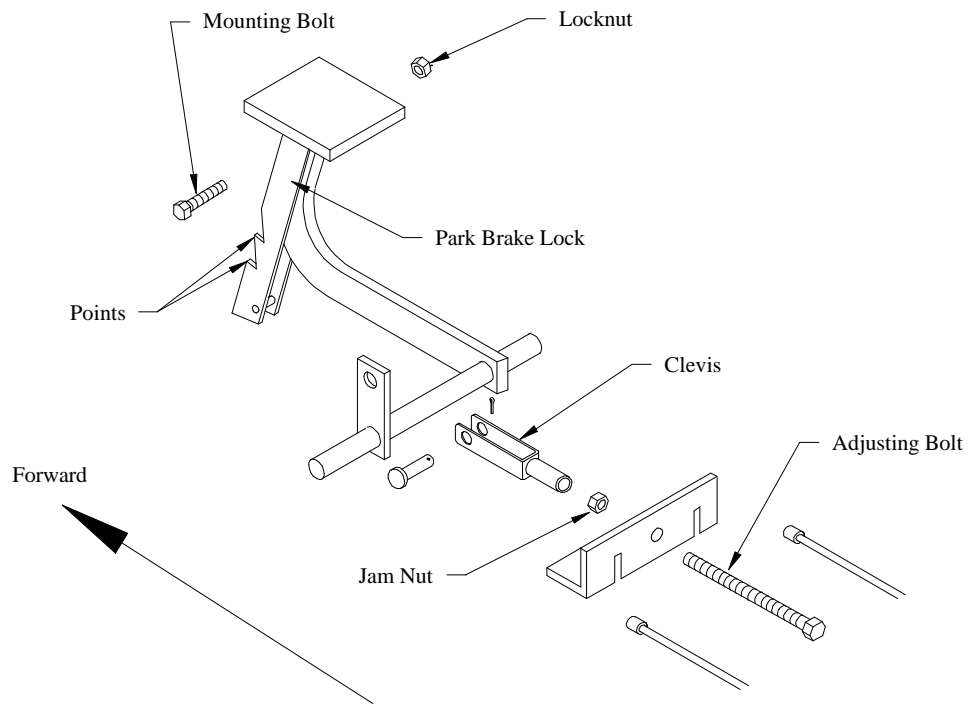

**Foot Brake Assembly: Shown is the brake pedal, and how it connects to the brake cables on the SS5-36, SS5-46 and MX-600.**

---

### Replacement and Wear of Park Brake Lock (All Models)

In the following procedure, you will be told how to replace the Park Brake Lock assembly:

1. Park the vehicle on a clean flat surface and block the rear wheels to prevent movement.
2. Turn the key off and place the forward/reverse switch in neutral.
3. Disconnect the main positive and negative terminals from the battery.
4. With the brake pedal in its fully extended position, remove the 1/2" bolt and locknut from under the pedal.

### **⚠ WARNING**

**Always use new locknuts and bolts. Locknuts and bolts become less effective if used more than once. If the locknuts or bolts holding the brake to the drive come loose, serious injury may occur.**

5. Remove the pedal and park brake lock assembly from the brake arm.
6. Install a new pedal and park brake lock assembly, following steps 4 through 5 in reverse order. (Substituting the word *install* for *remove* in steps 4 and 5.)

In the following procedure, you will be told how to check the Park Brake Lock for Wear.

1. After removing the park brake lock, inspect the points of the notches on the park brake lock.
2. If they are broken or worn, replace the assembly with a new one as instructed above.

#### Wear Limits:

If you apply the park brake lock and it does not catch or slips easily it must be replaced.

Press on the lower half of the pedal if the park brake lock engages with little effort on the upper most notch. Check the linkage adjustments and adjust as needed.

## SECTION 3

---

### SS5-36, SS5-46 and MX-600 Rear Brakes

The rear brakes are mechanical, auto adjusting, drum brakes and require no periodic adjustments to ensure safe operation. Servicing of these brakes consists of replacing the brake drum and brake shoes when they become worn.

In this section, we will cover how to inspect and replace the brake drum and shoes.

#### **Wear Limit:**

##### *Brake Shoes-*

Measure the brake shoe at various locations. It should be thicker than 1/16" at its thinnest point. If you measure 1/16" or less at any given point the shoes must be replaced.

##### *Brake Drum-*

The brake drum should be replaced if it is scored or damaged. The presence of grooves or damage on the inside diameter of the drum can effect the braking capabilities of the vehicle.

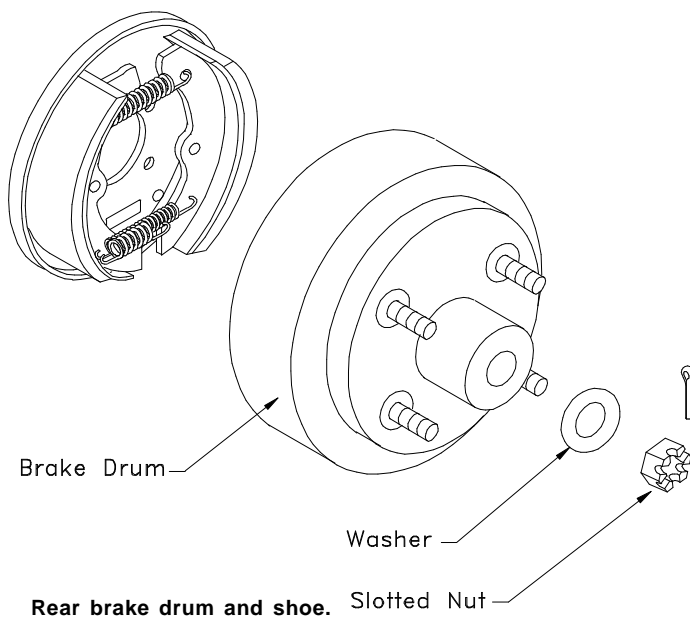

---

## Replacing the Brake Drum

To replace the rear brake drum, use the following procedure:

1. Raise the rear of the vehicle one side at a time. Placing jack stands under the vehicle to support it. ***Do not Attempt*** to raise the rear end by placing jacks or other lifting devices in the center of the rear end.

### **⚠ WARNING**

**Always use a lifting strap, hoist, and jack stands of adequate capacity to lift and support the vehicle. Failure to use lifting and supporting devices of rated load capacity to support the vehicle may result in serious injury and property damage.**

2. Remove the rear wheel and tire assembly.
3. Remove the cotter pin, castle nut, and washer from the end of the axle shaft.
4. Remove the brake drum.
5. Inspect the inside of the brake drum for wear or damage. If it is grooved or damaged, it must be replaced.
6. Visually inspect the brake shoes for wear.
7. Install the new brake drum.
8. Repeat steps 1 through 3 in reverse order.

## SECTION 3

---

### Replacing the Brake Shoes

To replace the brake shoes, use the following procedure.

1. Raise the rear of the vehicle until the rear wheels clear of the floor and place jack stands under the vehicle. Raise the rear of the vehicle one side at a time. Placing jack stands under the vehicle to support it. ***Do not Attempt*** to support or raise the rear end by placing jacks or other lifting devices in the center of the rear end.

#### **▲ WARNING**

**Always use a lifting strap, hoist, and jack stands of adequate capacity to lift and support the vehicle. Failure to use lifting and supporting devices of rated load capacity to support the vehicle may result in serious injury and property damage.**

2. Remove the rear tire and wheel assembly.
3. Remove the cotter pin, castle nut, and washer from the end of the axle shaft.
4. Remove the brake drum.
5. Inspect the inside of the brake drum for wear or damage. If it is grooved or damaged it must be replaced.
6. Remove the brake shoe springs
7. Remove the brake shoe hold down spring from each shoe.
8. Remove the brake shoes and adjusting assembly.
9. Disassemble and clean the adjusting screw assembly.
10. Apply Hi-Temp grease to the adjusting screw assembly, hold-down, and retracting spring contacts on the brake shoes.
11. Install the adjusting screw assembly.
12. Install the brake shoe hold down springs.
13. Install the brake shoe springs.
14. Install the brake drums and tire/wheel assembly.
15. Pump the brakes to automatically adjust the brake shoes.
16. Lower to the ground and road test the vehicle.

**NOTE:** The brakes may pull slightly to one side or the other due to the auto self adjustment system. As the brake shoes wear, one side may automatically adjust before the other.

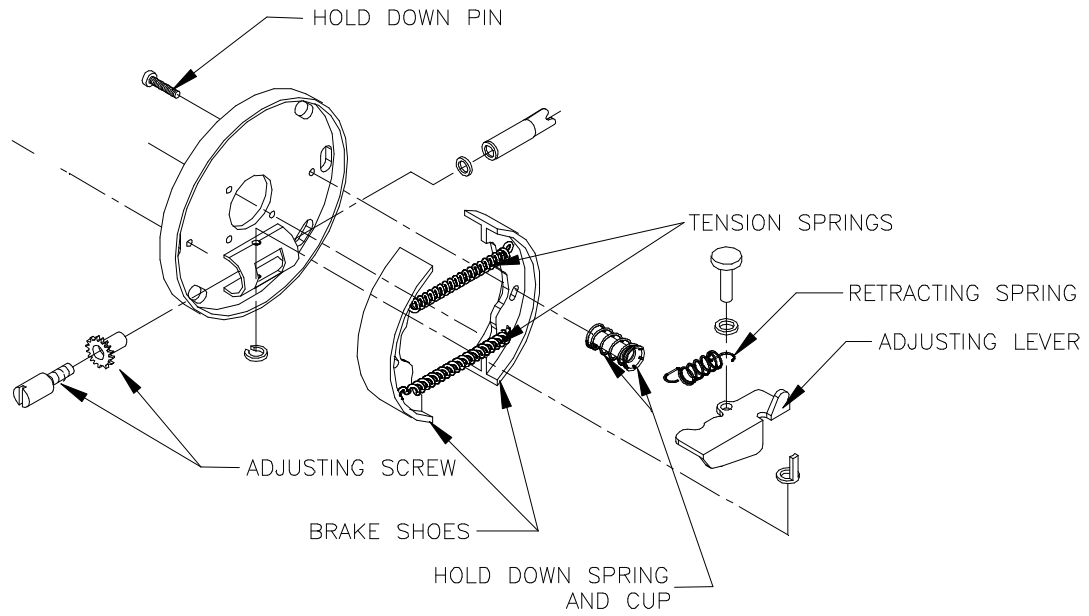

**Exploded view of mechanical rear brake assembly.**

## SECTION 3

# Front Fork and Steering

In this section, we will cover how to service and repair the front fork, axle, and steering assemblies. Included in the steering will be the tiller steering system and the geared steering system.

The standard steering assembly for the SS5-34, SS5-36, and MX-600 is the Tiller. Since the Geared option is widely used in these vehicles as well, we included it in this section. Geared steering is standard on the SS5-46.

## SS5-34 Geared Steering

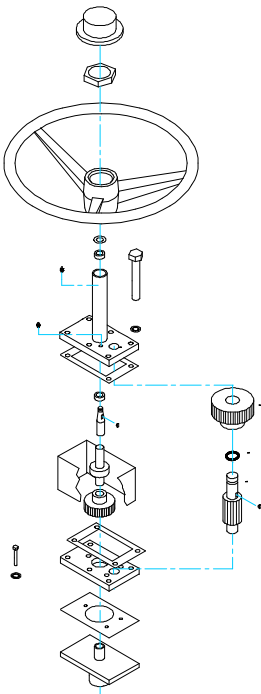

## SS5-36/5-46, MX-600 Geared Steering

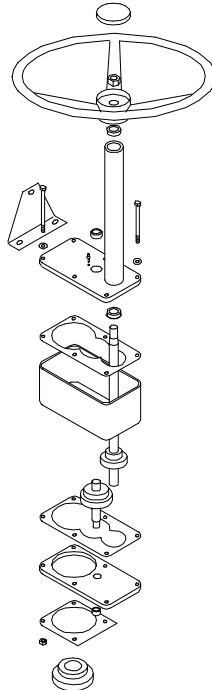

## SS5-34, SS5-36 and MX-600 Tiller Steering

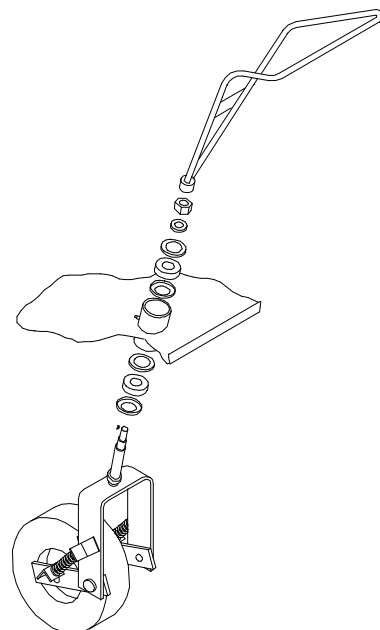



## Front Fork

Here, we will cover the Front Fork only. The following procedures will cover the disassembly and repair of the front fork and the axle. ,

**NOTE:** There are two types of front axles used within the serial numbers covered by this manual. The basic instructions for removing, servicing and installing are the same.

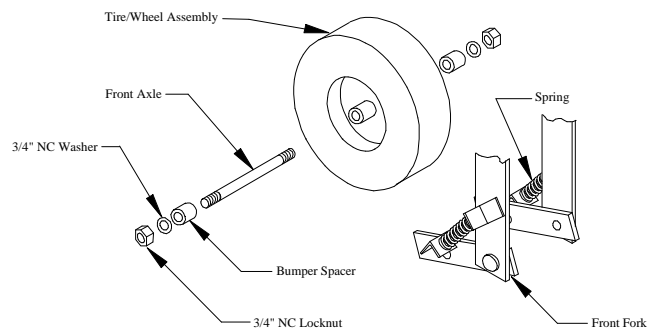

**Axle assembly using two axle nuts**

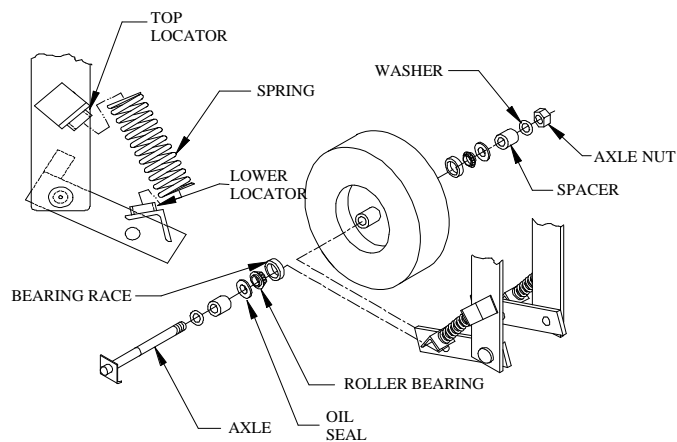

**Axle assembly using one axle nut**

## SECTION 3

---

### Removing the Front Fork

In order to remove the front fork follow these procedures.

1. Park the vehicle on a clean level surface.
2. Turn the key off and place the forward/reverse switch in the neutral position.
3. Block the rear wheels to prevent movement.
4. Loosen the spindle mounting nut on the tiller and remove it from the steering shaft.
5. Remove the woodruff key from its slot on the steering shaft.
5. Remove the locknut located from the top of the steering shaft.
6. Raise the front of the vehicle, allowing the steering shaft to slide through the cowl.

NOTE : The fork should be supported to prevent it from putting undue pressure on the lower oil seal, bearing, and bearing race. This is also done to prevent the fork from falling once it is removed from the cowl and damaging these parts.

### **⚠ WARNING**

**Always use a lifting strap, hoist and jack stands of adequate capacity to lift and support the vehicle. Failure to use lifting and supporting devices of rated load capacity to support the vehicle may result in serious injury and property damage.**

7. Support the front fork to prevent it from falling as the front of the vehicle is raised.
8. Remove the fork, front axle, and springs.
9. Replace seals, bearings, and races as required.
10. Install the new fork in reverse order.

---

## Removing the Front Springs

In order to remove the front springs, follow these procedures:

1. Raise the front of the vehicle and support it with jack stands

### **⚠ WARNING**

**Always use a lifting strap, hoist, and jack stands of adequate capacity to lift and support the vehicle. Failure to use lifting and supporting devices of rated load capacity to support the vehicle may result in serious injury and property damage.**

2. Compress the front spring and slide it off the top locator.
3. Tilt the spring out away from the fork and remove it from the lower locator.
4. Install the new spring in reverse order, then lower the vehicle and test drive.

---

## Removing the Front Axle

This can be done with the fork still in the vehicle or while it is removed. To remove and replace the front axle assembly, use the following procedure.

1. Raise and support the front of the vehicle.

### **⚠ WARNING**

**Always use a lifting strap, hoist, and jack stands of adequate capacity to lift and support the vehicle. Failure to use lifting and supporting devices of rated load capacity to support the vehicle may result in serious injury and property damage.**

2. Remove the axle nut and washer from the axle.
3. Pull the axle through the fork slowly.  
**NOTE:** Do not let the spacers, oil seals, roller bearings or bearing races fall out while removing the axle. Be sure that these parts can be removed without damaging them or letting them drop to the floor.
4. Install the new axle in reverse order.

## SECTION 3

---

### Replacing the Front Wheel Bearings

To replace worn or damaged wheel bearing, follow the procedure below:

1. Park the vehicle on a level surface.
2. Using the appropriate procedure, remove the front wheel from the fork assembly.
3. Remove the oil seal, bearings and bearing races from the wheel.
4. Install new bearing races, bearings and oil seals.

### **⚠ WARNING**

**Always use new locknuts and bolts. Locknuts and bolts become less effective if used more than once. If the locknuts or bolts holding the brake to the drive come loose, serious injury may occur.**

5. Install the axle through the fork and wheel.  
NOTE: Remember to install the spacers and outer washers in their proper location while installing the axle.
6. Install and tighten the axle locknut.
7. Tighten the axle locknut until the wheel slightly drags when it is rotated by hand.
8. Inject grease into the wheel using a grease gun on the hubs grease fitting.
9. Lower the vehicle and test drive.

---

### Replacing and Adjusting the Front Fork Collar Bearing

In order to replace and adjust the collar bearings, use the following procedure:

1. Park the vehicle on a level surface.
2. Raise the front of the vehicle and support it with jack stands.
3. Using the appropriate procedure, remove the fork and steering tiller.
4. Remove the upper and lower bearing, bearing race, and oil seal.
5. Install the new bearings, races, and oil seals.
6. Install the front fork and the spindle mounting nut.
7. Tighten the spindle mounting nut while rotating the fork manually.  
Continue tightening the nut until it requires 2ft-lbs of torque to rotate the fork assembly.
8. Loosen the nut slowly until the fork turns freely.
9. Install the tiller.
10. Lower the vehicle and test drive.



## Optional Geared Steering

Here, we will cover the optional geared steering assembly. This assembly is an option on all three vehicles.

In this section, we will cover how to remove and service this steering system.

---

### SS5-34 Geared Steering Assembly

In order to disassemble this steering gear box, follow this procedure. Refer to the illustration on the following page.

1. Park the vehicle on a level surface and block all the wheels.
2. Remove the cap from the center of the steering wheel.
3. Remove the nut from the center of the steering wheel.
4. Remove the steering wheel and woodruff key from the shaft.
5. Remove the 6 bolts from the top cover.
6. Lift the top cover off the gear box, discarding the gasket.  
**NOTE:** The spur gear and shaft may come out of the gear box when removing the top cover. Do not let the gears drop to the floor.
7. Remove as much grease as possible from the inside of the gear box and dispose of it properly.
8. Remove the gear case and clean the remaining grease from the bottom of the gear box.
9. Remove and discard the lower gasket.
10. Remove the 3 remaining bolts from the bottom of the gear box.
11. Clean all parts except for the gaskets in solvent.
12. Reassemble in reverse order, installing new gaskets.  
**NOTE:** Check the bronze bushings for wear and replace them as needed.
13. Fill the gear box with grease.

SECTION 3

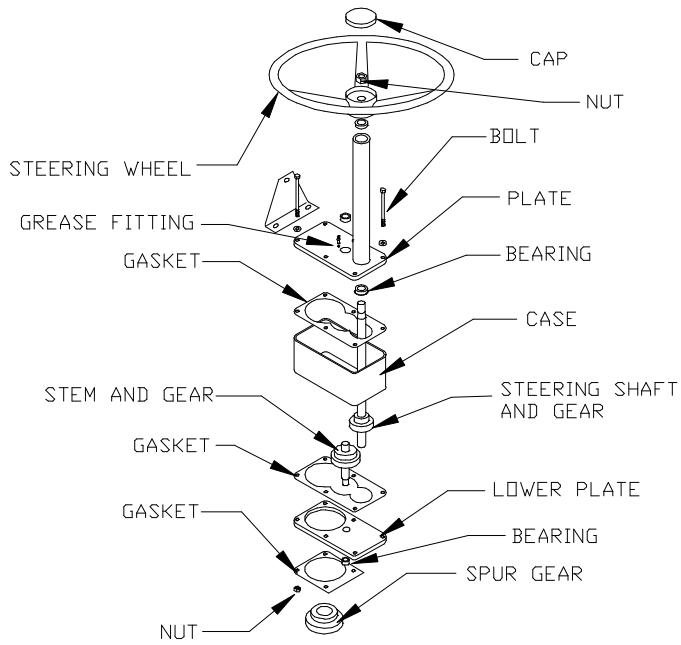

**SS5-36, SS5-46 and MX-600 Optional Geared Steering**

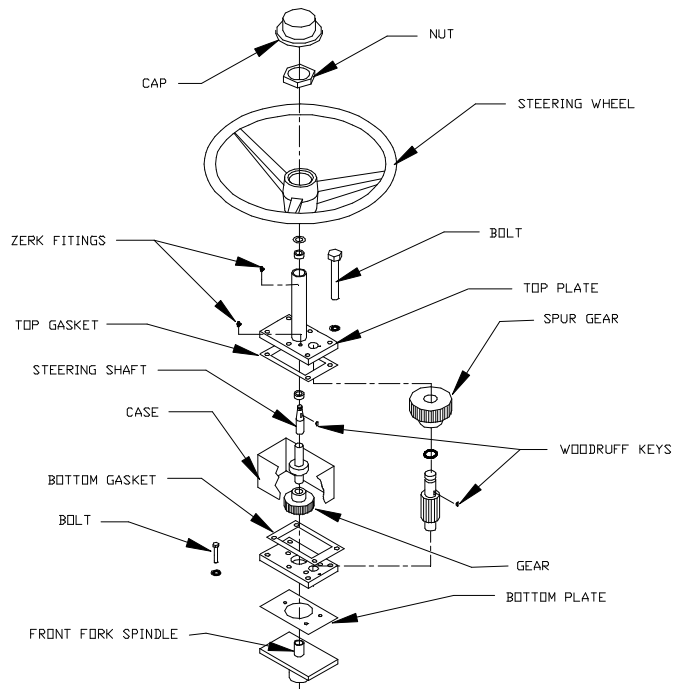

**SS5-34 Optional Geared Steering Assembly**

---

### SS5-36, SS5-46 and MX-600 Steering Assembly

In order to disassemble this steering gear box, follow this procedure. Refer to the illustration on the previous page.

1. Park the vehicle on a level surface and block all the wheels.
2. Remove the cap from the center of the steering wheel.
3. Remove the nut from the center of the steering wheel.
4. Remove the steering wheel from the shaft.
5. Remove the 6 bolts from the top cover.
6. Lift the top cover off the gear box, discarding the gasket.  
NOTE: The stem and gear may come out of the gear box when removing the top cover. Do not let the gear drop to the floor.
7. Remove as much grease as possible from the inside of the gear box and dispose of it properly.
8. Remove the gear case and clean the remaining grease from the bottom of the gear box.
9. If the stem and gear did not come out with the top cover, remove it now.
10. Remove and discard the lower gasket.
11. Clean all parts, except for the gaskets in solvent.
12. Reassemble in reverse order installing new gaskets.  
NOTE: Check the bronze bushings for wear and replace them as needed.
13. Apply grease to all gears.

## SECTION 3

### SS5-46 Front Axle and Steering

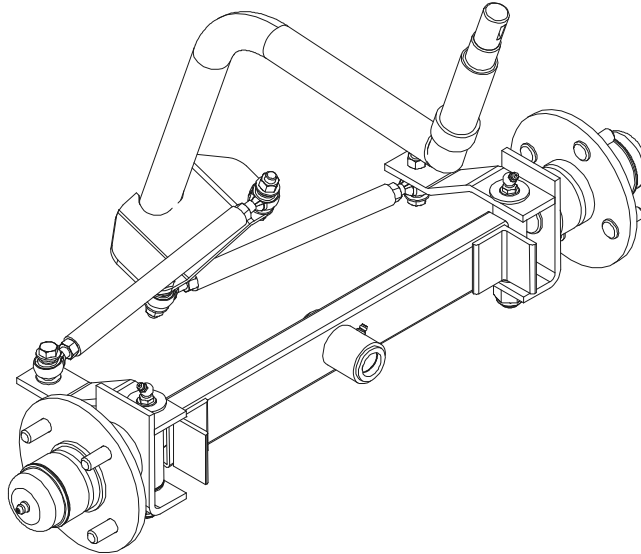

---

#### Replacing the Front Wheel Bearings

To replace worn or damaged wheel bearing, follow the procedure below:

1. Park the vehicle on a level surface.
3. Raise the front of the vehicle and support it with jack stands.
4. Using the appropriate procedure, remove the front wheel from the hub.
5. Using the appropriate procedure, remove the hub from the axle assembly.
6. Remove the oil seal, bearings and bearing races from the hub.
7. Install new bearing races, bearings and oil seals.
8. Install in reverse order using a new cotter pin.
  - a. Tighten the spindle nut to 30 ft-lbs and then back off one flat and install the new cotter pin
9. Inject grease into the wheel using a grease gun on the hubs grease fitting.
10. Lower the vehicle and test drive.



---

### Removing the Front Axle Assembly

To remove and install the front axle assembly, follow the procedure below:

1. Park the vehicle on a level surface.
2. Raise the front of the vehicle and support it with jack stands.
3. Remove both front wheels.
4. Remove the left and right rod ends from the steering knuckles.
5. Remove the front axle pivot pin nut and remove the front axle assembly from the frame.
6. Install in reverse order.
7. Lower the vehicle and test drive.

---

### Aligning the Front Wheels

To adjust the front wheel toe-in, follow the procedure below:

1. Park the vehicle on a level surface.
2. Turn the front wheels so that they are in the straight ahead position.
3. Measure the distance between the centers at the front of the tires.
4. Measure the distance between the centers at the rear of the tires.
5. Adjust the tie rods so that the distance is the same at the front and rear of the tires.
6. Test drive.

---

### Replace the King Pins or Bushings

To replace the king pins or bushings, follow the procedure below:

1. Park the vehicle on a level surface.
2. Raise the front of the vehicle and support it with jack stands.
3. Remove the wheel from the front axle.
4. Remove the king pin and tie the steering knuckle out of the way.
5. Drive the king pin bushings out from the axle end.
6. Press the new bushings into the axle end.
7. Install the king pin and wheel.
8. Lower the vehicle and test drive.

## SECTION 3

# Rear Axle and Drive Assembly

In this section, we will cover how to install, remove, and service the rear axle and drive assemblies.

### **SS5-36, SS5-46 and MX-600**

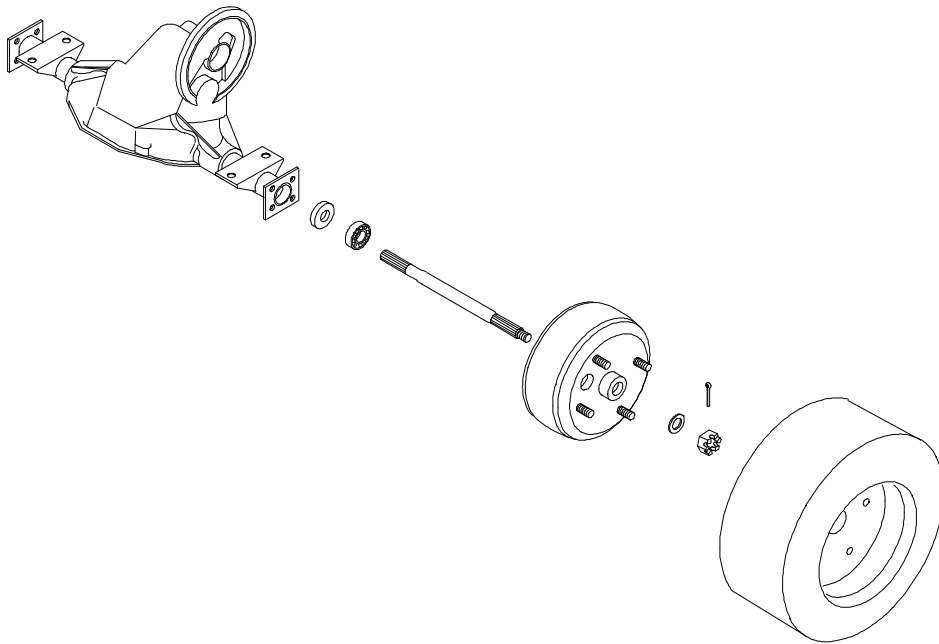

## Removing the SS5-34 Rear End Assembly

Here, we are referring to the complete assembly including wheels, axle, housing, drive, and drive motor. In order to remove this complete assembly from the vehicle, use the following procedure:

1. Park the vehicle on a clean level surface.
2. Disconnect the batteries.
3. Lift the front of the vehicle and place blocks under the frame.

### **⚠ WARNING**

Always use a lifting strap, hoist, and jack stands of adequate capacity to lift and support the vehicle. Failure to use lifting and supporting devices of rated load capacity to support the vehicle may result in serious injury and property damage.

4. Lower the front of the vehicle onto jack stands.
5. Raise the deck board and disconnect the motor wires.
6. From under the vehicle, remove the brake linkage from the brake lever.
7. Remove the shock from its lower mount.
8. Remove the swing arm pivot bolts.
9. Raise the rear of the vehicle and remove the rear end assembly from the vehicle.
10. Install in reverse order.

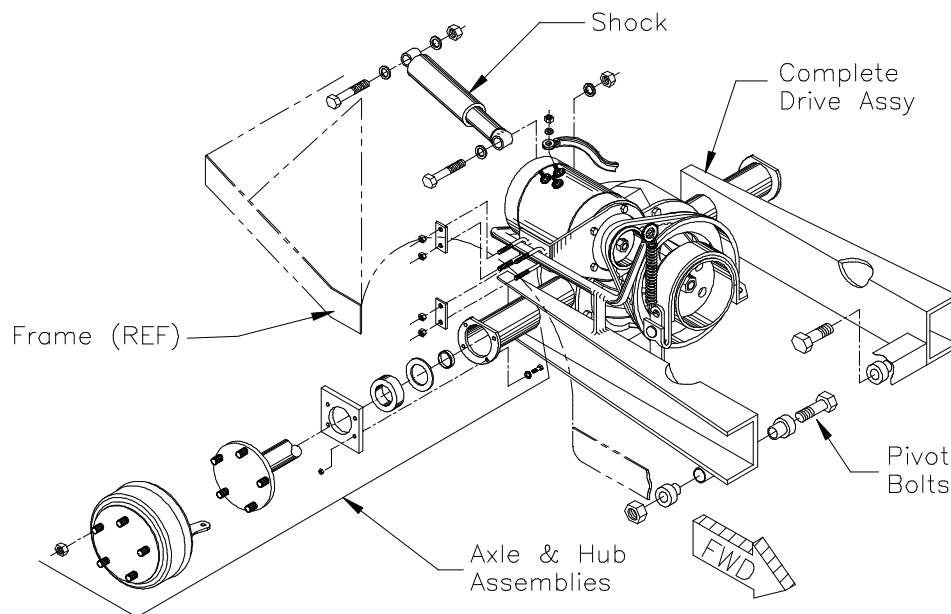

**Complete SS5-34 Drive and Rear End Assembly**

## SECTION 3

### Removing the SS5-36 and SS5-46 Rear End Assembly

Here, we are referring to the complete assembly including wheels, axle, housing, drive, and drive motor. In order to remove this complete assembly from the vehicle, use the following procedure:

1. Park the vehicle on a clean level surface.
2. Disconnect the batteries.
3. Lift the front of the vehicle and place blocks under the frame.
4. Lower the front of the vehicle onto jack stands.

#### **⚠ WARNING**

**Always use a lifting strap, hoist, and jack stands of adequate capacity to lift and support the vehicle. Failure to use lifting and supporting devices of rated load capacity to support the vehicle may result in serious injury and property damage.**

5. Support the rear end assembly with a jack and jack stands.
6. Remove the bolts mounting the rear coil springs to the drive frame and lower the entire frame and rear end assembly.
7. Raise the rear of the vehicle and support it with jack stands.
8. Disconnect the wires from the motor.
9. Disconnect the brake cables.
9. Remove the bolts from the rear end mounting brackets holding the rear end assembly to the drive frame.
10. Remove the rear end assembly from the vehicle.
11. Install in reverse order.

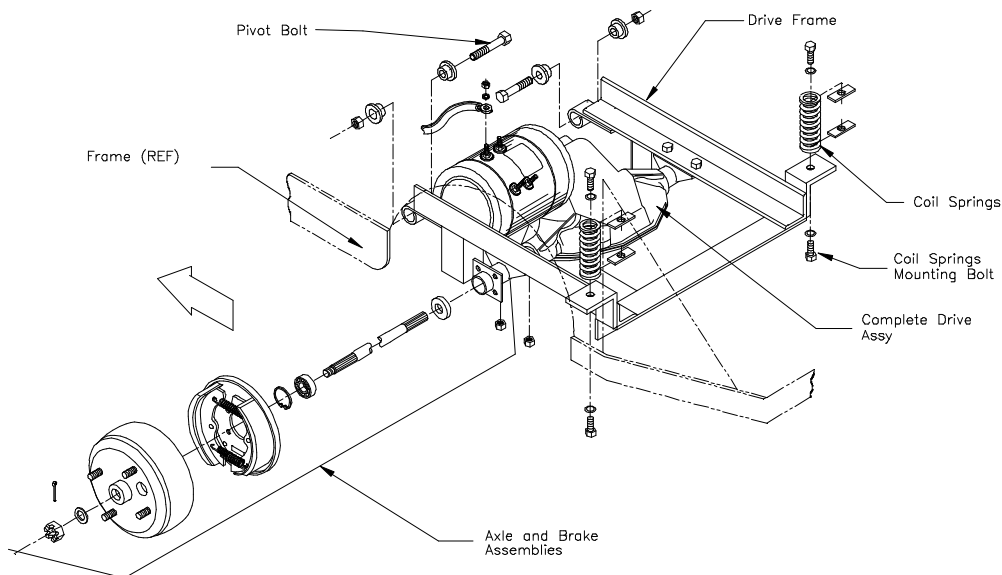

**Complete SS5-36/SS5-46 Drive and Rear End Assembly**

## Removing the MX-600 Rear End Assembly

Here, we are referring to the complete assembly including wheels, axle, housing, drive, and drive motor. In order to remove this complete assembly from the vehicle, use the following procedure:

1. Park the vehicle on a clean level surface.
2. Disconnect the batteries

### **⚠ WARNING**

**Always use a lifting strap, hoist and jack stands of adequate capacity to lift and support the vehicle. Failure to use lifting and supporting devices of rated load capacity to support the vehicle may result in serious injury and property damage.**

3. Lift the front of the vehicle and place blocks under the frame.
4. Lower the front of the vehicle onto jack stands.
5. Raise the rear of the vehicle and support it with jack stands.  
NOTE: You may want to remove the tires in order to make it easier to remove the mounting bolts from the frame.
6. Place another set of jack stands under the drive assembly, and remove the bolts mounting the drive assembly to the frame.
7. Lower the entire rear end assembly.
8. Disconnect the brake cables.
9. Disconnect the wires from the motor
10. Remove the rear end assembly from under the vehicle.
10. Install in reverse order.

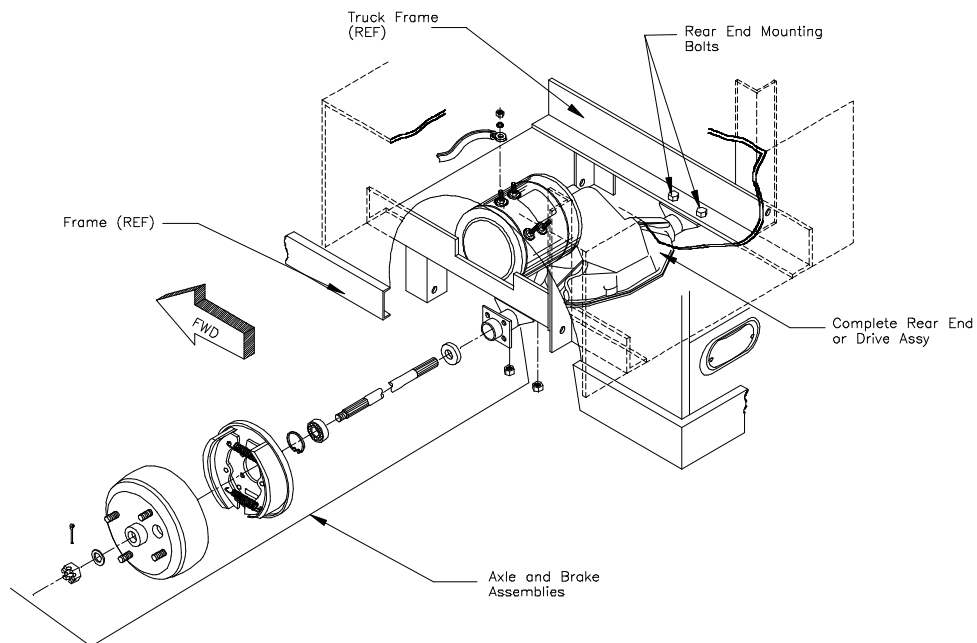

**Complete MX-600 Drive and Rear End Assembly**

## SECTION 3

### Differential and Rear Axle

The differential and rear axle assemblies are slightly different between the SS5-34 and the SS5-36/5-46 and MX-600. For this reason, we have divided this section into two separate sub sections. The first is for the SS5-34 and the second for the SS5-36, SS5-46 and MX-600.

The SS5-34 has a belt driven differential, while the SS5-36, SS5-46 and MX-600 are both direct drive, helical gear driven differentials.

In these sections, we will cover how to disassemble and service these differential and rear axle assemblies. The belt adjustments for the belt drive system will be included.

To properly service the differential, it will have to be removed. At this point, we are assuming that the entire assembly has been removed from the vehicle and has been placed on a clean, level work area or on a stand, designed to hold such an assembly. An exception to this is when the axles need to be serviced. Then, the entire rear end assembly does not need to be removed. However, for simplicity, all of the following instructions have been written as if the rear end assembly has been removed from the vehicle.

## SS5-34 Drive Service

To properly service this assembly, it will have to be removed. At this point, we are assuming that the entire assembly has been removed from the vehicle and has been placed on a clean, level work area or on a stand designed to hold such an assembly.

### Disassembly of The Belt Drive Assembly

1. Disconnect the batteries.
2. Remove the brake.
3. Loosen the motor mount clamp nuts and the Belt adjusting bolt locknut.
4. Turn the Belt adjusting bolt until the belts can be removed without prying or forcing them off.
5. Remove the belts.
6. Remove the motor by removing the motor mount clamp nuts.
7. Remove the pulley from the pinion shaft.
8. Inspect the seal in the pinion bearing retainer. Replace it if it is worn or damaged.
9. Reassemble in reverse order and adjust the belt tension and the pulley alignment using the appropriate procedures.

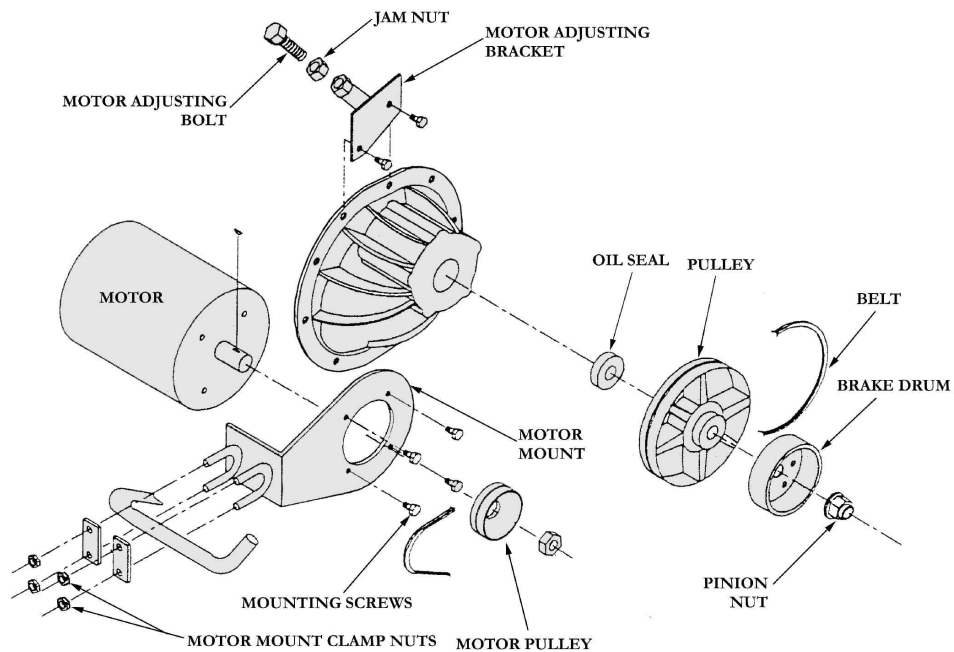

## SECTION 3

### SS5-34 Removing and Servicing the Rear Axle

This procedure does not require that the rear end or drive assembly be removed in order to complete. However, if the rear end assembly is removed from the vehicle, you may skip procedure #1.

1. Raise and support the rear of the vehicle.

#### **⚠ WARNING**

**Always use a lifting strap, hoist and jack stands of adequate capacity to lift and support the vehicle. Failure to use lifting and supporting devices of rated load capacity to support the vehicle may result in serious injury and property damage.**

2. Remove the tire and wheel assembly.
3. Remove the four bolts attached to the axle retaining plate.
4. Pull the axle out of housing.
5. Remove the bearing gasket.
6. Inspect all bearings for roughness or play. Replace the bearings as needed.

#### **⚠ CAUTION**

**If the bearings are removed from the axle, the axle retainer and bearings must be replaced with new ones. Failure to replace these parts could result in the axle coming out of the vehicle while driving.**

7. Inspect the axle for metal fatigue.
8. Install a new rear axle in reverse order.



## SS5-34 Differential Service and Repair

1. Raise the drive wheels and support the vehicle with jack stands.

### **▲ WARNING**

Always use a lifting strap, hoist and jack stands of adequate capacity to lift and support the vehicle. Failure to use lifting and supporting devices of rated load capacity to support the vehicle may result in serious injury and property damage.

2. Drain the oil from the drive.
3. Remove the belt drive assemblies.
4. Remove the rear wheels.
5. Slide the axles out from the drive housing.
6. Remove the third member mounting nuts and third member from the housing.
7. Mark the carrier bearing flanges to insure that they can be installed in the same orientation during reassembly.
8. Remove the carrier bearing flanges and the carrier assembly from the housing.

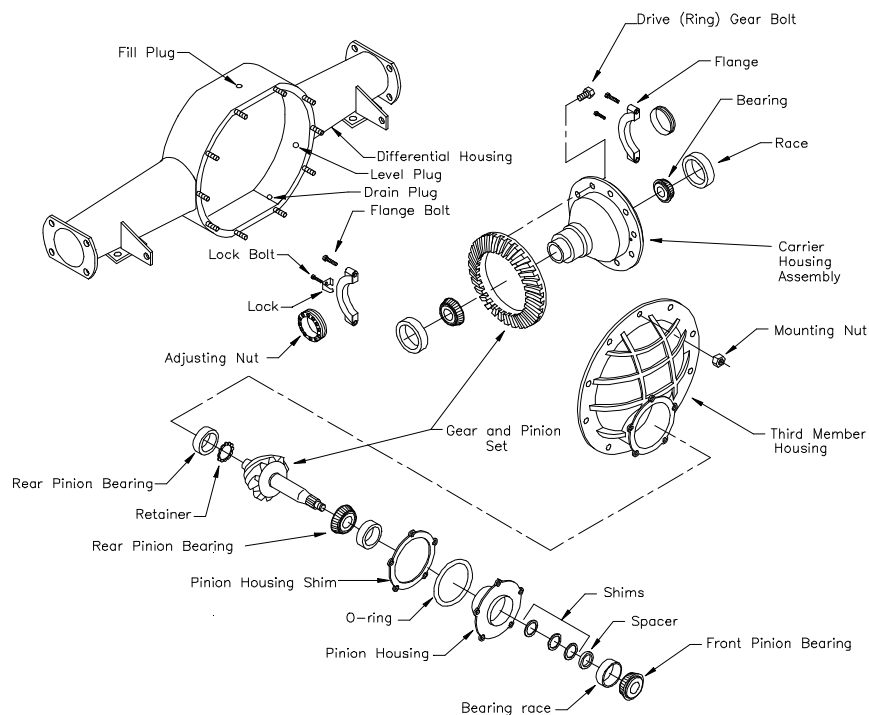

**Differential Assembly for the SS5-34**

## SECTION 3

8. Remove the pinion housing assembly from the third member.  
NOTE: Do not lose the shims!
9. Replace bearings, bearing races, and gears as needed.
10. Reassemble in reverse order and follow the instructions in Adjusting Backlash and Reshimming the Pinion Bearing
  - a. Pre-lube all bearings and gears during reassembly.
  - b. Cross tighten ring gear bolts to 72 ft.-lbs.
  - c. If pinion bearing or gears are replaced, the drive must be reshimmed.
  - d. Use new seals.

### Adjusting Backlash

1. Install the correctly shimmed pinion gear and pinion gear housing.
2. Temporarily install the drive sprocket and brake drum. Torque the pinion nut to 175ft.-lbs.
3. Tighten the carrier bearing cap bolts to 15 ft.-lbs.
4. Position the carrier assembly against the pinion gear. While rotating the carrier, turn the adjusting nuts to contact the carrier bearings.
5. Loosen the adjusting nut on the toothed side of the ring gear.
6. Tighten the other nut so that there is no gear backlash, but not so tight to cause binding.
7. Tighten the adjusting nut on the toothed side of the ring gear so that there is .008 to .012 backlash.
8. Tighten the carrier bearing cap bolts to 40-55 ft.-lbs.

### Reshimming the Pinion Bearing

1. Remove the pinion housing from the third member.
2. Install the drive gear and brake drum (or equivalent spacer) on to the pinion shaft and tighten to 175ft.-lbs.
3. Check the torque required to rotate the pinion shaft. Torque spec is 7 to 10 in-lbs.  
NOTE: Do not rotate bearings when dry. They must have a lubricant or they will be damaged.
4. Add or remove shims as necessary to obtain the correct torque.



### Selecting Pinion Housing Shims

The pinion housing shims are available in thickness from 0.005” to 0.021”, in increments of 0.001”, to correctly position the pinion gear. However, the standard shim thickness is 0.015” thick.

The following numbering system is used on pinions to indicate the amount you must add or subtract from the standard shim in order to correctly position the pinion gear. Locate the number on the flat surface on the small shaft at the end of the pinion gear. Match the number with the shim required.

Pinon Numbering System	
If the Number is	Add Shim(s) as Follows
+0	No Adjustment
+1	Add .001 Shim
+2	Add .002 Shim
+3	Add .003 Shim
+4	Add .004 Shim
+5	Add .005 Shim
-1	Subtract .001 Shim
-2	Subtract .002 Shim
-3	Subtract .003 Shim
-4	Subtract .004 Shim
-5	Subtract .005 Shim

## SECTION 3

---

### Changing the Differential Oil

1. Place a 3 quart or larger drain pan under the drive.
2. Remove the differential drain plugs.
3. Replace the drain plugs and remove the differential fill and level plugs.
4. Install oil into the differential through the filler hole until the oil starts to come out of the level hole (approximately 2 quarts).
5. Install the level plug.
6. Install the remaining plugs.

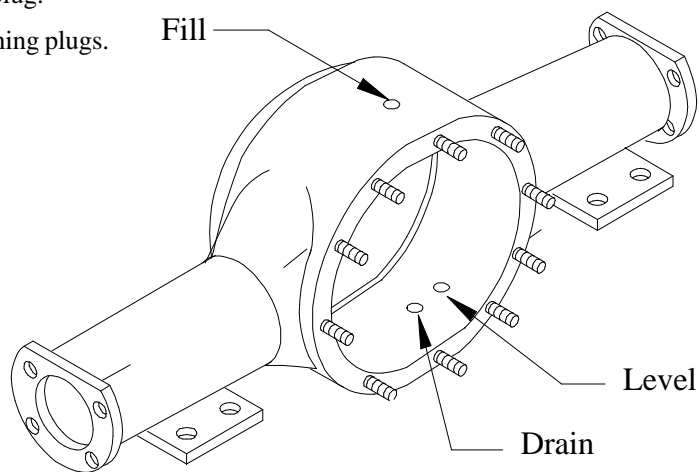

---

### Motor Removal

In order to remove the motor from the drive assembly, use the following procedure:

1. Park the vehicle on a level surface and block the wheels to prevent movement, then disconnect the batteries.
2. Remove the deck board and place it out of the way.
3. Disconnect the batteries.
4. Mark the wire leads on the motor to insure their proper location when reinstalling the motor.
5. Remove the wire leads from the motor and loosen the motor mount clamp.
6. Loosen the drive belt adjusting bolt lock nut and turn the adjusting bolt until the belts can be easily removed.
7. Remove the drive belts from the motor pulley.
8. Remove the four motor mounting bolts.
9. Remove the motor assembly from the vehicle.
10. Install in reverse order, adjust the drive belts

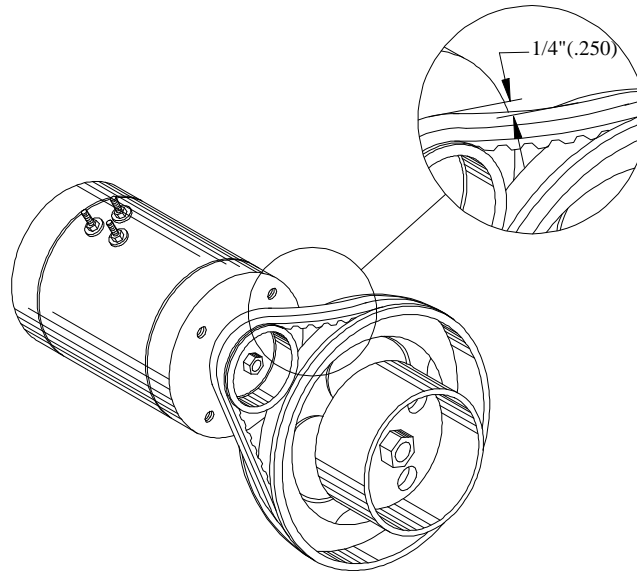

**Belt Deflection of 1/4" (.250")**

---

### Adjusting Belt Tension

Whenever the belts are removed from the pulleys or as the belts become worn, the belt tension must be readjusted. In order to adjust the belt tension, follow these procedures:

1. Check the alignment of the pulleys. The face of the pulleys should be in line with each other.
2. Loosen the lock nut on the belt adjusting bolt.
3. Turn the adjusting bolt in or out as needed to tension the belts properly.

**NOTE:** There should be a 1/4" deflection in the belts at the mid point between the two pulleys.

4. Check the deflection in the belts, then rotate the pulleys one full turn. Check the deflection again.
5. If the deflection is correct, tighten the lock nut on the motor adjusting bolt. If the deflection is not correct, repeat steps 2 through 4 again.

## SECTION 3

### Aligning Pulleys

To align the pulleys, use the following procedure:

1. Loosen the motor mount clamp nuts and move the motor either forward or backward until the two pulley faces are in line with each other.
2. Tighten the motor mount clamp nuts and check the belt deflection. Adjust the belts as needed.

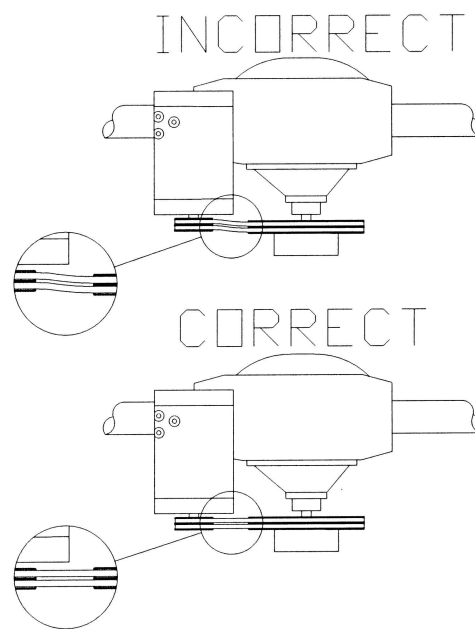

**Belt Drive Pulley Alignment**

---

### SS5-36, SS5-46 and MX-600 Drive Service

To properly service this assembly, it will have to be removed from the vehicle. At this point, we are assuming that the entire assembly has been removed from the vehicle and has been placed on a clean, level work area

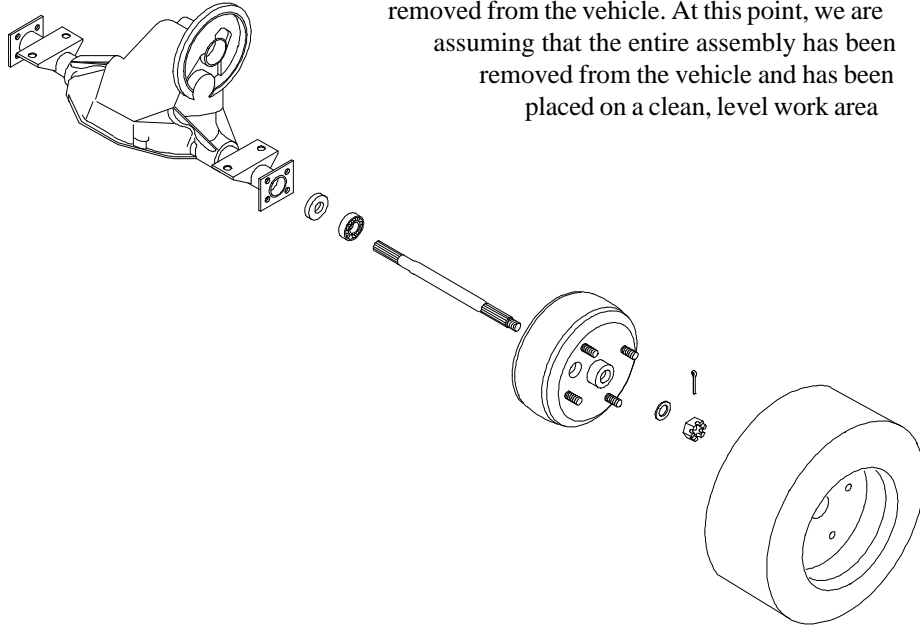

#### SS5-36, SS5-46 and MX-600 Drive Assembly

#### SS5-36/SS5-46/MX-600 Removing and Servicing the Rear Axle

This specific procedure does not require that the rear end or drive assembly be removed in order to complete. Refer to the illustration on the following page.

1. Raise and support the rear of the vehicle with a hoist or other suitable lifting device.

### **WARNING**

**Always use a lifting strap, hoist and jack stands of adequate capacity to lift and support the vehicle. Failure to use lifting and supporting devices of rated load capacity to support the vehicle may result in serious injury and property damage.**

2. Remove the tire and wheel assembly.
3. Remove the four bolts attached to the axle retaining plate.
4. Pull the axle out of the housing.
5. Remove the bearing gasket.
6. Inspect all bearings for roughness or play. Replace the bearings as needed.
7. Inspect the axle for metal fatigue.
8. Install a new rear axle in reverse order.







6. Remove the differential case assembly from the housing.
7. Remove the differential bearings from each side of the case.
8. Remove the drive gear from the case.
9. Punch or drill a 1/8" hole in the center of each bearing bore plug.
10. Insert a suitably sized sheet metal screw into the hole until the bore plug is forced out of the bearing bore.
11. Remove the snap ring from each bearing bore.
12. Drive the intermediate shaft from the flange side of the housing.  
NOTE: Use a brass drift pin to drive the shaft from the housing.
13. Remove the intermediate bearings from the housing.
14. Remove the O-Rings from the intermediate shaft.
15. Remove the snap rings from the input shaft bore.
16. Pull the input shaft assembly from the housing.
17. Remove the bearings from the input shaft.
18. Remove the O-Rings from the outer input bearing bore and both intermediate bearing bores.
19. Inspect all parts for signs of wear or damage.  
NOTE: Bearing, seal, and gear surfaces should be inspected for pitting, wear, overheating, or scoring. Replace these parts as needed.
20. Thoroughly clean all parts.
21. Lubricate all parts with SAE 30 motor oil.
22. Press inner and outer bearings on to the input shaft.
23. Install the input shaft.
24. Install the outer snap rings and O-Rings onto the intermediate shaft.
25. Assemble the intermediate shaft and gear assembly through the bottom opening of the housing.  
NOTE: The Small end of intermediate shaft and gear assembly must be tilted toward the bottom opening, until the bearing trunnion visually engages the intermediate bores.
26. Align both the bearing trunnions with intermediate bores.
27. Insert the flange side bearing into the opening.

## SECTION 3

28. After the flange side bearing is seated install the snap ring.
29. Repeat procedures for opposite side.
30. Align the final drive gear mounting holes with the differential case, install the four bolts through the differential case, and secure the drive gear in place by tightening the nuts.  
NOTE: The bolts should be installed from the flange side of the differential case.
31. Press the differential bearings onto the differential case.
32. Position the drive housing with the opening facing up and install the differential assembly.
33. Install the differential bearing caps  
NOTE: Remember that the bearing caps are marked. Be sure to reinstall the bearing caps back into their original position.
34. Install the bearing cap screws and torque them to 35-45 ft. lbs.
35. Install the cover plate and torque the cover plate screw to 18-28 ft. lbs.
36. Install new intermediate bore plugs into both sides of the housing.  
NOTE: Bore plugs should be firmly against the snap rings when fully seated.
37. Fill differential housing with 10 ounces of SAE 30 motor oil.

## Motor

### SS5-36/SS5-46/MX-600 Motor Removal

To remove the motor from the differential use the following procedure:

**NOTE: IF YOU ARE SERVICING A MX-600 THE DIFFERENTIAL AND REAR END ASSEMBLY MUST BE REMOVED FROM THE VEHICLE TO COMPLETE THIS TASK. IF YOU ARE SERVICING A SS5-36, YOU MAY SIMPLY REMOVE THE DECK BOARD TO GAIN ACCESS TO THE MOTOR.**

1. Disconnect the batteries.
2. Support the motor.
3. Label the wires connected to the motor to insure that they are returned to their proper location.
4. Remove the wires from the motor.
5. Remove the motor mounting bolts from the drive.
6. Pull the motor away from the drive and set on a clean, level surface.
7. Install the new motor or reassemble in reverse order.

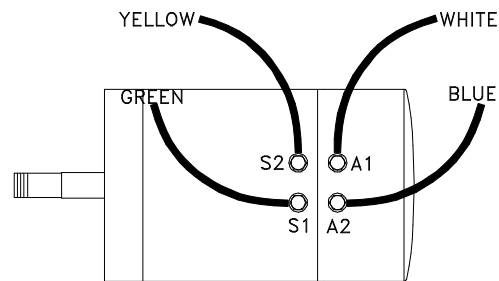

**Wire Connections on Motor**

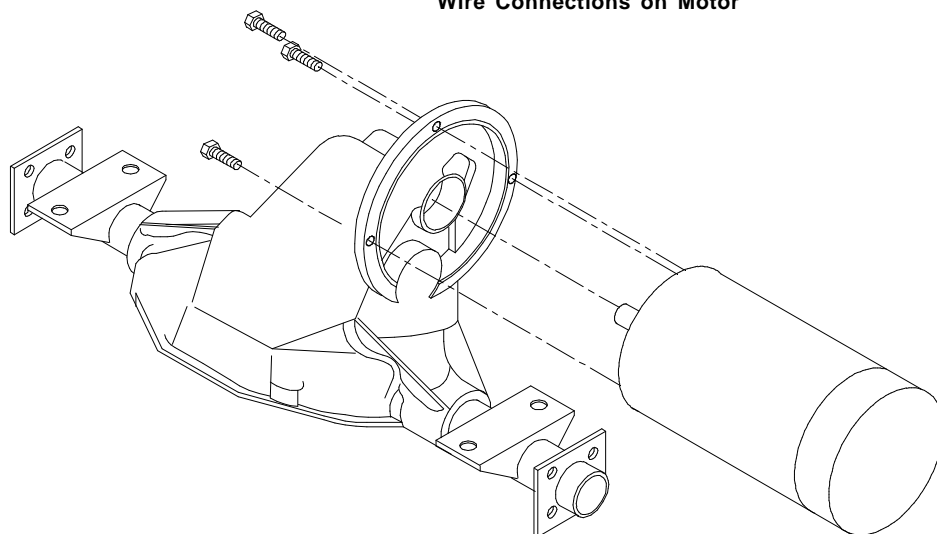

**Motor Mounted on Assembled SS5-36, SS5-46 and MX-600 Differential**

## SECTION 3

### SS5-34 Motor Removal

1. Park the vehicle on a level surface and block the wheels to prevent movement. Disconnect the batteries.
  2. Remove the deck board and place it out of the way.
  3. Mark the wire leads on the motor to insure their proper location when reinstalling the motor.
  4. Remove the wire leads from the motor and loosen the motor mount clamp.
  5. Loosen the motor adjusting bolt lock nut and turn the adjusting bolt until the belts can be easily removed.
  6. Remove the belts.
  7. Remove the four motor mounting bolts from the face of the motor.
  8. Remove the motor assembly from the vehicle.
  9. Install in reverse order and adjust the belts using the appropriate procedure.
- 

#### Brushes

The motor brushes must be checked regularly for wear. Use the following procedure to check the brushes in the motor for wear:

1. Remove the motor from the drive assembly.
2. There is a small inspection hole above each of the four brushes. Insert a .035" rod or paper clip into the inspection hole until it contacts the top of the brush. Mark the rod and measure how far it was inserted into the motor.
3. If the rod travels into the hole 1.5" or more, then the brushes must be replaced. Inspect all four brushes.

NOTE: We recommend that all the brushes be replaced at the same time.

### Installing New Brushes

In order to install new brushes in the motor use the following procedure:

1. Remove the motor from the rear end assembly.
2. Remove the motor cover revealing the brush holder and brushes.
3. Disassemble the brush studs from the cover.
4. Remove the old brushes and install the new ones.
5. Inspect the commutator for wear.
6. Replace the motor cover and reinstall the motor on the rear end assembly.

### Motor Disassembly

1. Remove the motor.
2. Disassemble the motor.  
**NOTE:** Mark the housing to insure proper alignment when reassembling.
3. Inspect the armature and commutator.
4. If the bearings were removed due to wear, install new bearings on the shaft. (Other wise continue on to step #5.)
5. Reassemble the motor.
6. Install the motor onto the rear end assembly.

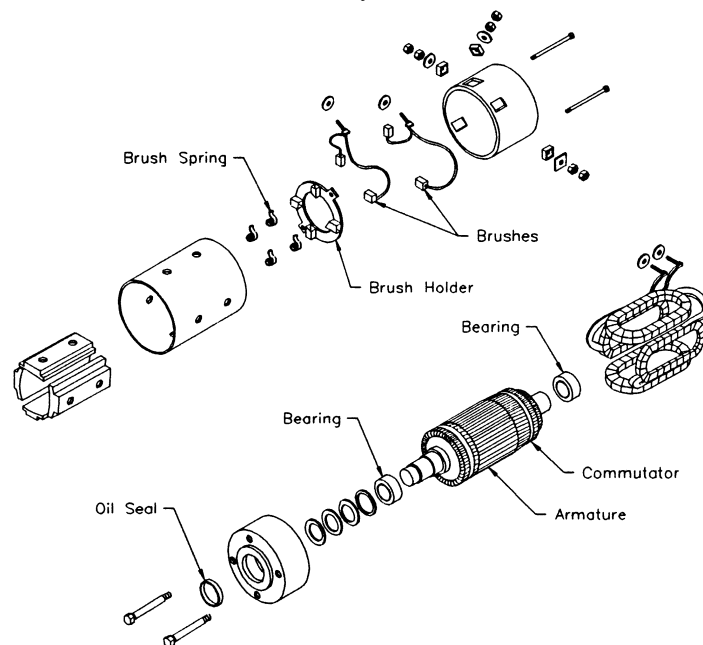

**Exploded View of Motor for All Models**

## SECTION 3

### Inspecting the Armature

1. If any solder has been thrown from the armature the motor must be replaced.  
NOTE: Check the inside of the motor housing around the commutator for bits of solder.
2. If the commutator is grooved, it must be cut on a lathe.
3. Measure the undercut on the commutator.
  - a. If less than .025", then the mica must be undercut.
4. Measure the commutator diameter.
  - a. If less than 3.109", then the armature is worn out and the motor must be replaced.
5. Spin the bearings by hand.
  - a. If any vibration or roughness is felt, they must be replaced.

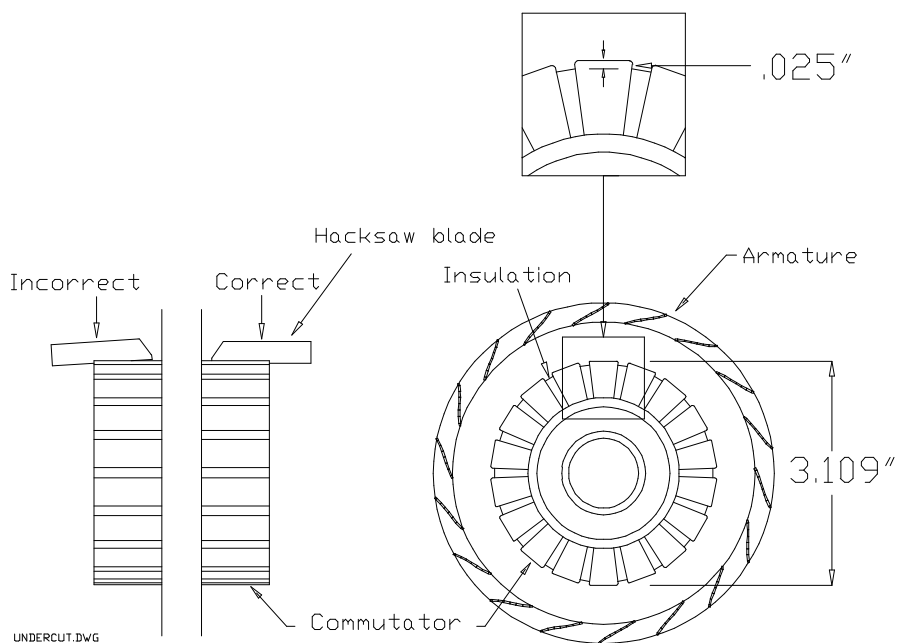

**Correct Way to undercut the Commutator and Correct Mica Depth**

## Battery

### Cleaning

1. Dry dirt can be readily blown off with low-pressure air or brushed off.
2. Wetness or wet dirt on the covers indicates battery acid. Using a nonmetallic brush with flexible bristles, wash it off with a strong solution of baking soda and hot water (1 lb. of soda to gallon of water). Continue until all fizzling stops, which indicates that the acid has been neutralized. Then rinse thoroughly with clear water. DO NOT get any of the solution into the battery cells.

### **⚠ WARNING**

**Battery electrolyte is poisonous and dangerous. It contains sulfuric acid. Avoid contact with skin eyes or clothing. Wear rubber gloves and safety glasses while servicing batteries. DO NOT INGEST!**

### **⚠ WARNING**

**Batteries produce an explosive gas when charging. DO NOT SMOKE, produce an open flame or spark while checking or servicing a battery.**

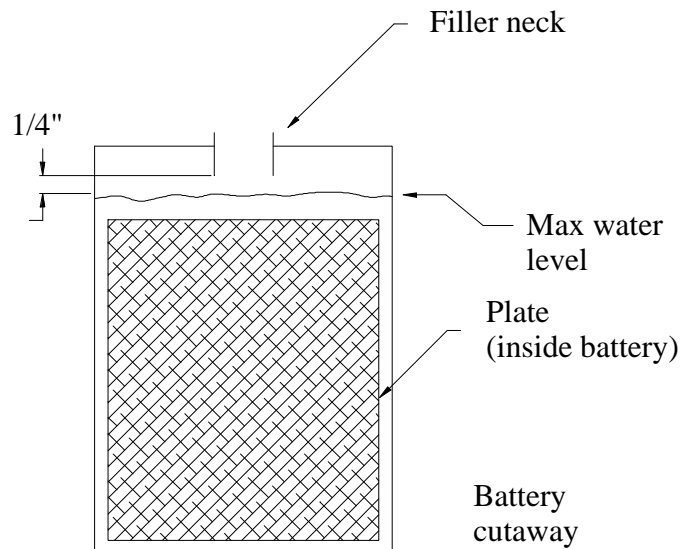

## SECTION 3

### Servicing the Batteries

1. Check the electrolyte level in all batteries. If low, fill with distilled water up to the correct level.

#### **⚠ CAUTION**

**Do not overfill the battery. An overfilled battery may leak acid.**

2. Clean the battery.
3. Clean the cell posts connectors and battery box with water.

---

### Charging

#### **To charge the batteries do the following:**

1. Check the electrolyte level. If low, fill with distilled water up to the correct level.

#### **⚠ WARNING**

**Explosive mixtures of Hydrogen gas are present within battery cells at all times. Do not work with or charge battery in an area where open flames (including gas furnace or water heater pilots), sparks, cigarettes, or any other sources of combustion are present. Always provide ample ventilation in rooms where batteries are being charged.**

2. Park the vehicle in an approved area for charging and plug the charger in.
3. Allow the charger to cycle completely before unplugging.

### Battery Storage

The following pointers will help extend the life of the battery when storing your vehicle for the winter season:

- Clean and check the electrolyte level and charge level of the battery. Do not store a battery low in electrolyte or in a low state of charge.
- Recharge a battery not in use every 1 to 2 months.
- If possible, store the vehicle in a cool, dry place.

If the batteries are removed from the vehicle, do not place them directly on the ground, concrete or solid metal surface. It is recommended to store them on a wooden pallet or equivalent.



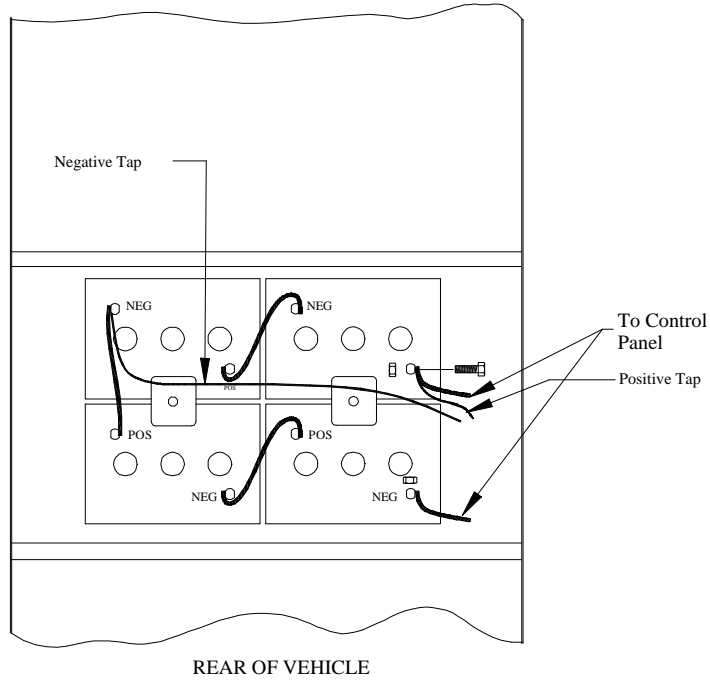

**Battery Configuration: Shown are the batteries and how they are connected together for the SS5-34, SS5-36 and SS5-46.**

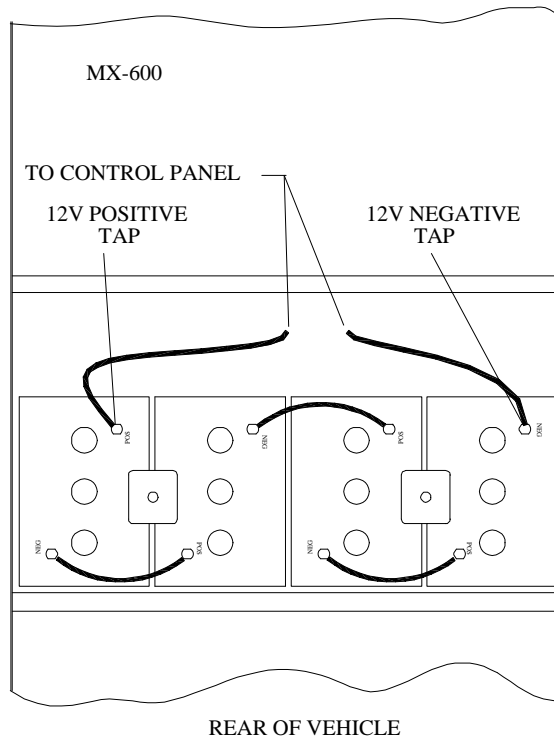

**Battery Configuration: Shown are the batteries and how they are connected together for the MX-600.**

**TAYLOR - DUNN**

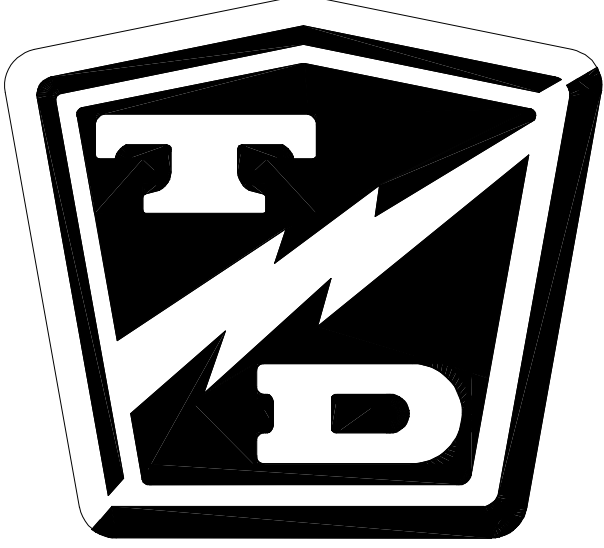

## SECTION 4-Electrical Troubleshooting

---

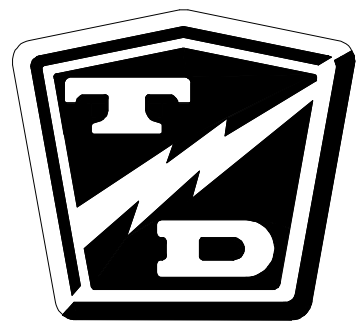

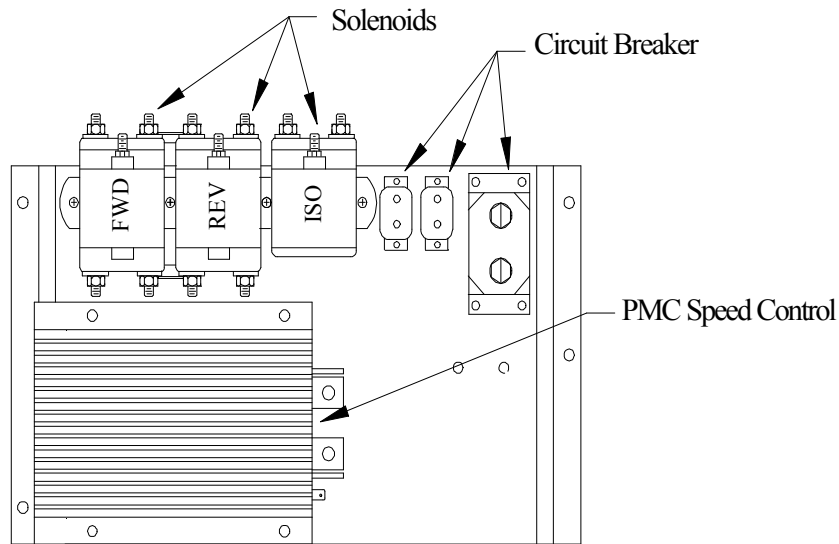

Typical Control Panel

## **Syptoms:**

If your vehicle exhibits any of the following symptoms then skip the main troubleshooting sequence and proceed to **Special Troubleshooting** in Section 4 at the end of the main troubleshooting sequence.

- Runs slow in both directions plus high armature and field current in both directions. NOTE: Armature and field current should be equal.
- Runs slow in both directions plus high armature current in both directions. NOTE: Field current will be very low.
- Runs normal in one direction only plus runs slow or lacks power in the opposite direction with high armature current in the opposite direction or;
- Accelerates slowly and exceeds normal speed in the opposite direction with high armature current only. NOTE: Field current will be very low in the opposite direction.
- Accelerates slowly and exceeds normal speed in both directions plus high armature current. NOTE: Field current will be very low.
- Full speed only.
- Does not run in either direction plus there is noise from motor (hum or whine) with high field current and low armature current.
- Jumps into high speed when direction is selected after depressing the accelerator pedal. Excessive spark when connecting battery
- Does not run or runs very slow with low motor current and high battery current.
- Jumps into high speed when direction is selected after depressing the accelerator pedal.

If your vehicle does not exhibit any of the above symptoms then continue with the main troubleshooting sequence on the following pages.



## Main Troubleshooting Sequence

### Test Equipment Required:

- Digital multimeter (DMM) with diode test function, FLUKE 79 model used in illustrations.
- Shunt or clamp-on DC Ammeter to measure up to 400 amps.
- Test light with a rated voltage equal to or exceeds maximum battery voltage or Taylor-Dunn test light part number #62-027-00 for systems up to 48 volts.
- Test harness, Taylor-Dunn #62-027-31. This troubleshooting guide assumes that the vehicle is wired correctly. It is not intended to diagnose a vehicle that is not wired correctly.
- These tools are available through your local Taylor-Dunn parts distributor.

### IMPORTANT NOTES and INSTRUCTIONS

- This troubleshooting guide assumes that the vehicle is wired correctly. It is not intended to diagnose a vehicle that is not wired correctly.
- This troubleshooting guide is not written to be able to locate a problem if there are multiple component failures.
- This troubleshooting guide assumes the batteries are good. Charge and test the batteries before troubleshooting the control system.
- DO NOT start in the middle of this troubleshooting guide. Start at the beginning and complete each test in the order that they are written. Do not skip any test unless instructed to do so. Once a problem is found, stop testing and repair the indicated problem. When the repair is completed it is recommended that the control system be retested before lowering the drive wheels to the ground.

### **⚠ CAUTION**

**These test procedures must be performed in the order they were written. If the test result is good, then proceed to the next test or go to the next section. Failure to do so may result in incorrect test results.**

- This troubleshooting guide requires the use of a test light rated at the battery voltage of the truck and the Taylor-Dunn Accelerator Module Test Harness. Troubleshooting CANNOT be completed without these tools.



## Definitions:

- “MS-1” = The first switch in the accelerator module.
- “Battery volts” = The voltage at the batteries at the time the test is completed.
- “Pick up” = Energizing a solenoid or contactor.
- “F&R” = Forward and Reverse.
- “ISO” = Isolator.
- “Battery negative” = Main negative battery post.
- “Battery positive” = Main positive battery post.
- “PMC” = Speed control module (black box).
- “HOT terminal” = The side of a switch or solenoid that is connect to the power source.
- “COLD terminal” = The side of a switch or solenoid that power is switched to.

## DURING ALL TESTS

### **⚠ WARNING**

**After any repairs are made, completely retest the vehicle before lowering the drive wheels to the ground. Failure to retest the vehicle could result in unexpected movement of the vehicle resulting in injury or property damage.**

### **⚠ WARNING**

**The rear drive wheels may rotate during some of the following tests. Block the front wheels, raise the rear drive wheels off the ground, and support the vehicle with jack stands. Failure to do so may cause the vehicle to move and cause property damage and/or serious bodily injury.**

### **⚠ WARNING**

**Rotating rear drive wheels are a potential hazard. Keep hands, arms, legs and loose clothing away from the rear drive wheels while conducting tests. Failure to do so may cause serious bodily injury.**

### **⚠ WARNING**

**Disconnect both of the battery leads during any maintenance or before disconnecting any electrical component or wire. Failure to do so may cause property damage and/or serious bodily injury.**

## START:

Read all warnings above before continuing.

If the vehicle runs normal in one direction but does not run in the opposite direction then go to the ***Solenoids*** sequence.

If none of the three solenoids pick up (click) when the accelerator pedal is depressed then go to the ***Forward & Reverse Switch*** sequence.

## Power Output Test

### **⚠ WARNING**

1. Make sure the key-switch is in the "OFF" position, then remove the key.
2. Place the forward-reverse switch in the center "OFF" position.
3. Set the park brake.
4. Place blocks under the front wheels to prevent vehicle movement.

### **⚠ WARNING**

The rear drive wheels may rotate during some of the following tests. Block the front wheels, raise the rear drive wheels off the ground, and support the vehicle with jack stands. Failure to do so may cause the vehicle to move and cause property damage and/or serious bodily injury.

### **⚠ WARNING**

Rotating rear drive wheels are a potential hazard. Keep hands, arms, legs and loose clothing away from the rear drive wheels while conducting tests. Failure to do so may cause serious bodily injury.

Set the test light voltage to the same voltage as the battery volts.

Connect the test light from the PMC 'M-' Terminal to battery positive.

Close all interlock switches, turn the Key Switch ON, and place the F&R Switch in Forward.

**Depress the accelerator pedal fully.**

- If the light comes ON then go to the Motor sequence.
- If the light does not come ON then continue with the next test.

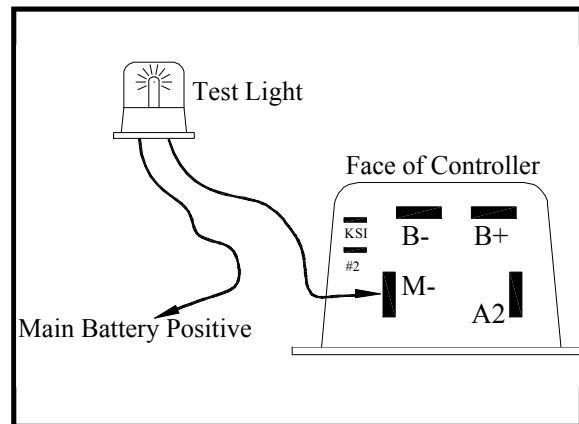



## Control Wire inputs Test

### ⚠ WARNING

1. Make sure the key-switch is in the "OFF" position, then remove the key.
2. Place the forward-reverse switch in the center "OFF" position.
3. Set the park brake.
4. Place blocks under the front wheels to prevent vehicle movement.

### ⚠ WARNING

The rear drive wheels may rotate during some of the following tests. Block the front wheels, raise the rear drive wheels off the ground, and support the vehicle with jack stands. Failure to do so may cause the vehicle to move and cause property damage and/or serious bodily injury.

### ⚠ WARNING

Rotating rear drive wheels are a potential hazard. Keep hands, arms, legs and loose clothing away from the rear drive wheels while conducting tests. Failure to do so may cause serious bodily injury.

Connect a voltmeter across the Solenoid Negative Buss Bar and battery positive.

- If the voltage is not at battery volts then check the wiring to battery negative and the negative circuit breaker. Stop trouble shooting here and repair the problem. When the repair is completed, completely retest the vehicle before lowering the drive wheels to the ground.

The voltage shown is for illustration only. The actual voltage may vary.

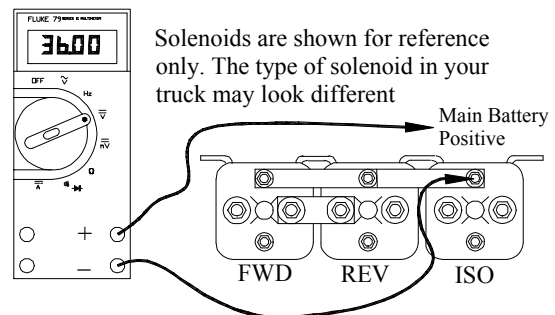

Connect a voltmeter across the ISO solenoid coil terminals.

**Close all interlock switches and turn the Key Switch ON.**

**Depress the accelerator pedal to engage MS-1 only.**

- If the voltage is not at battery volts then go to the **Key Switch** sequence.
- If the voltage is at battery volts and the ISO solenoid does not pick up (click) then the ISO solenoid has failed. Stop trouble shooting here and repair the problem. When the repair is completed, completely retest the vehicle before lowering the drive wheels to the ground.

The voltage shown is for illustration only. The actual voltage may vary.

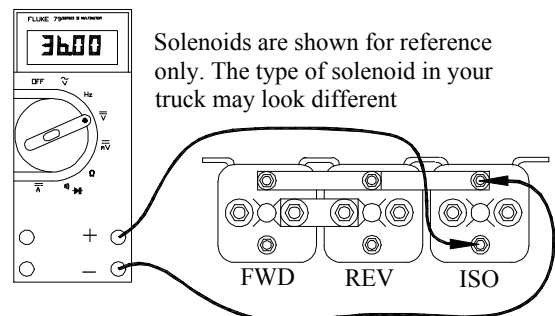



## Control Wire inputs (continued)

Connect a voltmeter across the PMC #2 terminal and battery negative.

Close all interlock switches, turn the Key Switch ON, and place the F&R Switch in Forward.

**Depress the accelerator pedal to engage MS-1 only.**

- If the voltage is not between 6.0 and 6.5 volts then go to the **Accelerator** sequence.

**Depress the pedal fully.**

- If the voltage is not between 11.0 and 11.5 volts then go to the **Accelerator** sequence.

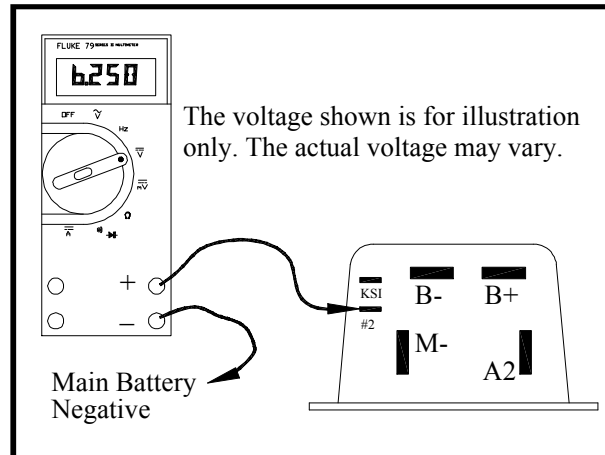

Connect voltmeter across the PMC KSI terminal and battery negative.

**With the pedal still fully depressed:**

- If the voltage is not at battery volts then go to the **Key Switch** sequence.
- If the voltage is at battery volts then continue with the next test.

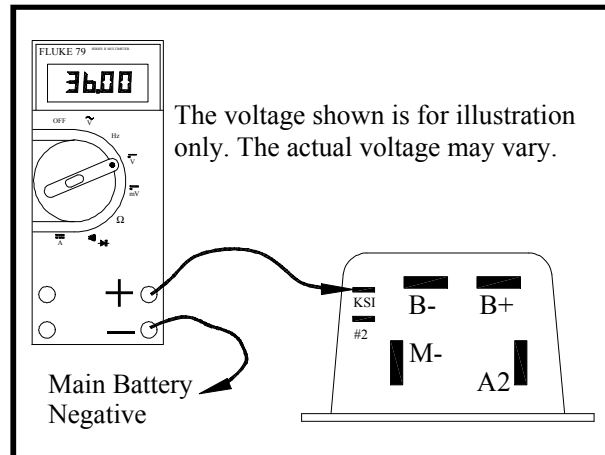



## Power Wire Inputs

### **⚠ WARNING**

1. Make sure the key-switch is in the "OFF" position, then remove the key.
2. Place the forward-reverse switch in the center "OFF" position.
3. Set the park brake.
4. Place blocks under the front wheels to prevent vehicle movement.

### **⚠ WARNING**

The rear drive wheels may rotate during some of the following tests. Block the front wheels, raise the rear drive wheels off the ground, and support the vehicle with jack stands. Failure to do so may cause the vehicle to move and cause property damage and/or serious bodily injury.

### **⚠ WARNING**

Rotating rear drive wheels are a potential hazard. Keep hands, arms, legs and loose clothing away from the rear drive wheels while conducting tests. Failure to do so may cause serious bodily injury.

Connect a voltmeter to the PMC 'B-' terminal and battery positive.

- If the voltage is not the same as battery volts then there is an open circuit in the wire from 'B-' to the battery. Stop troubleshooting here and repair the problem. When the repair is completed, completely retest the vehicle before lowering the drive wheels to the ground.

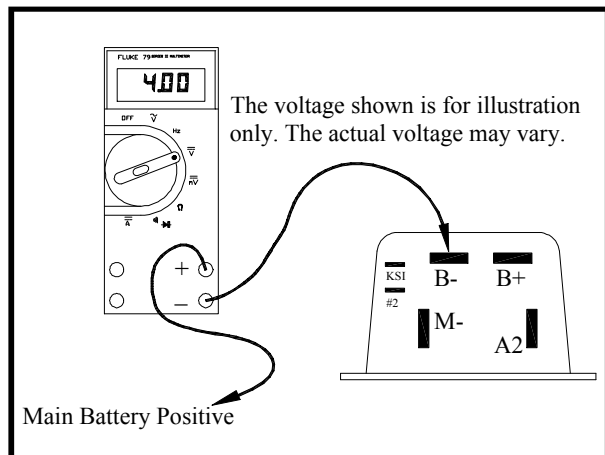

Connect a voltmeter across the PMC 'B-' terminal and the PMC 'B+' terminal.

**Close all interlock switches, turn the Key Switch ON, and place the F&R Switch in Forward.**

**Depress the accelerator pedal to engage MS-1 only.**

- If the voltage is not the same as battery volts then go to the **Solenoids** sequence.
- If the voltage is the same as battery volts then the PMC controller has failed. Stop trouble shooting here and repair the problem. When the repair is completed, completely retest the vehicle before lowering the drive wheels to the ground.

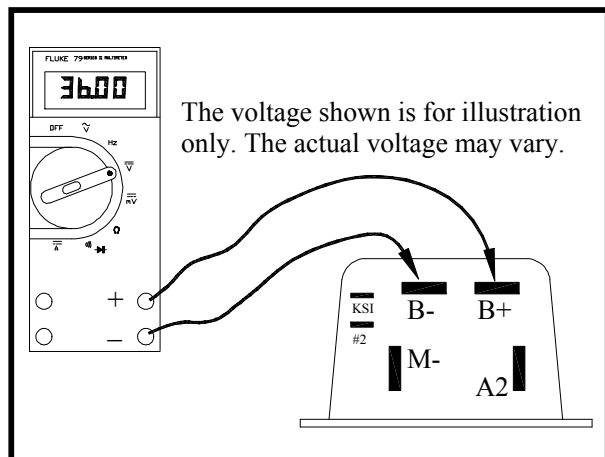

## Motor

### **⚠ WARNING**

1. Make sure the key-switch is in the "OFF" position, then remove the key.
2. Place the forward-reverse switch in the center "OFF" position.
3. Set the park brake.
4. Place blocks under the front wheels to prevent vehicle movement.

### **⚠ WARNING**

The rear drive wheels may rotate during some of the following tests. Block the front wheels, raise the rear drive wheels off the ground, and support the vehicle with jack stands. Failure to do so may cause the vehicle to move and cause property damage and/or serious bodily injury.

### **⚠ WARNING**

Rotating rear drive wheels are a potential hazard. Keep hands, arms, legs and loose clothing away from the rear drive wheels while conducting tests. Failure to do so may cause serious bodily injury.

Set the test light voltage to the same voltage as the battery volts.

Connect the test light across the motor 'A1' and 'A2' terminals.

**Close all interlock switches, turn the Key Switch ON, and place the F&R Switch in Forward.**

**Depress the accelerator fully.**

- If the light comes on then the motor armature windings are open and the motor must be repaired or replaced. Stop trouble shooting here and repair the problem. When the repair is completed, completely test the vehicle before lowering the drive wheels to the ground.

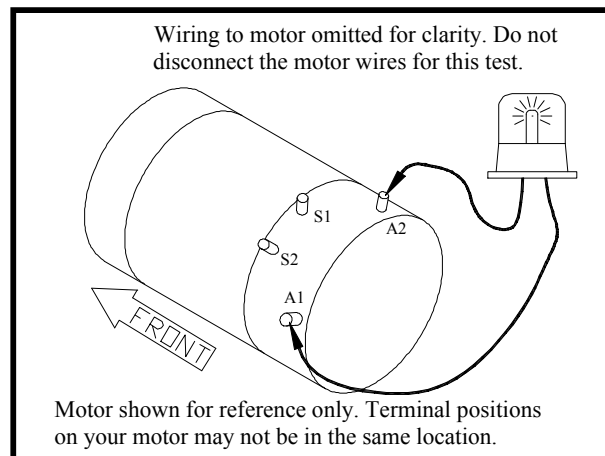



Connect the test light across the motor 'S1' and 'S2' terminals.

**Close all interlock switches, turn the Key Switch ON, and place the F&R Switch in Forward.**

**Depress the accelerator fully.**

- If the light comes on then the motor field windings are open and the motor must be repaired or replaced. Stop troubleshooting here and repair the problem. When the repair is completed, completely retest the vehicle before lowering the drive wheels to the ground.
- If the test light did not come on during either test then go to the **F/R Switch** sequence.

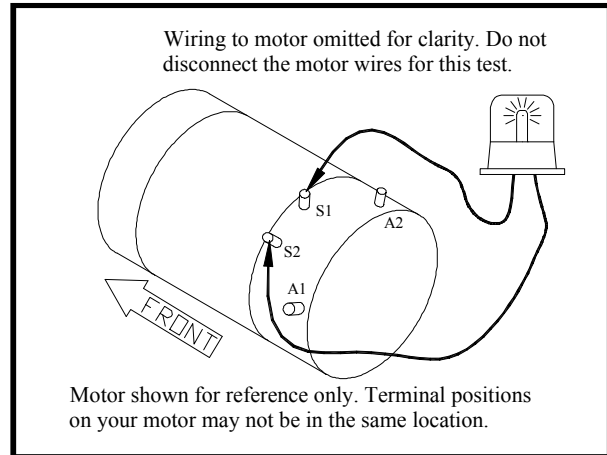

## Accelerator

### **⚠ WARNING**

1. Make sure the key-switch is in the "OFF" position, then remove the key.
2. Place the forward-reverse switch in the center "OFF" position.
3. Set the park brake.
4. Place blocks under the front wheels to prevent vehicle movement.

### **⚠ WARNING**

**The rear drive wheels may rotate during some of the following tests. Block the front wheels, raise the rear drive wheels off the ground, and support the vehicle with jack stands. Failure to do so may cause the vehicle to move and cause property damage and/or serious bodily injury.**

### **⚠ WARNING**

**Rotating rear drive wheels are a potential hazard. Keep hands, arms, legs and loose clothing away from the rear drive wheels while conducting tests. Failure to do so may cause serious bodily injury.**

This is the accelerator module test harness part number 62-027-31. It will be used in the following tests. These tests cannot be completed without this harness. If you do not have this harness, one must be obtained before testing can continue.

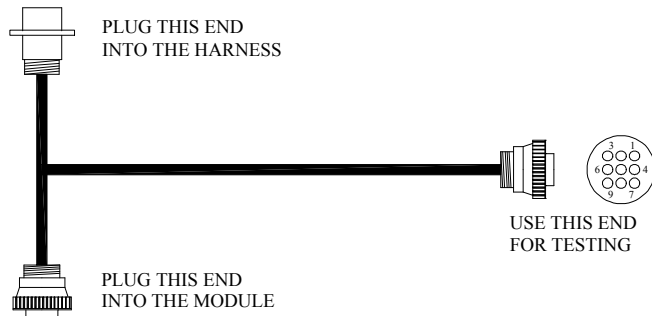

Connect the accelerator module test harness to the accelerator module.

Connect a voltmeter between pin #9 in the test harness and battery positive.

- If the voltage is not at battery volts then the wiring between pin #9 in the harness and battery negative is open. Stop trouble shooting here and repair the problem. When the repair is completed, completely retest the vehicle before lowering the drive wheels to the ground.

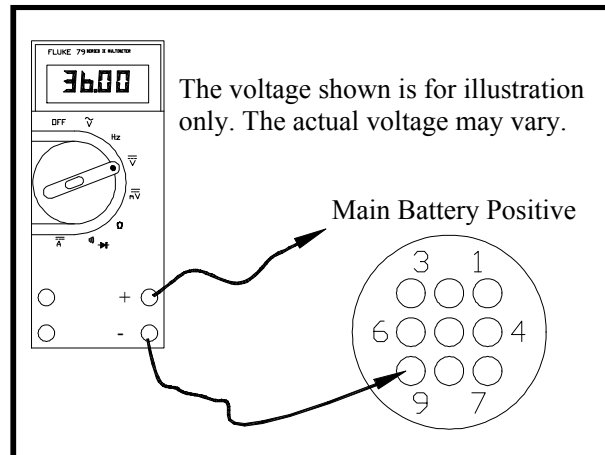

Connect a voltmeter negative probe to Pin #9 (-) in the test harness. Connect the positive probe to:

24 or 36 volt truck - Pin #4

48 volt truck - Pin #7

**Close all interlock switches and turn the Key Switch ON.**

- If the voltage is not at battery volts then go to the **Key Switch** sequence.

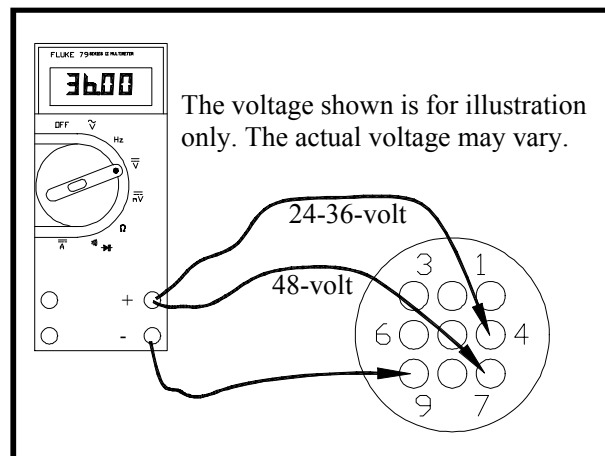

Connect a voltmeter between pin #9 (-) and pin #5 (+) in the test harness.

**Close all interlock switches and turn the Key Switch ON.**

**Depress the accelerator pedal to engage MS-1 only.**

- If the voltage is not at battery volts then the accelerator module has failed. Stop trouble shooting here and repair the problem. When the repair is completed, completely retest the vehicle before lowering the drive wheels to the ground.
- If the voltage at pin #5 is good but the test at the center terminal of the forward and reverse side of the F&R switch in the Key Switch Section failed then check the wire between the accelerator module pin #5 and the F&R switch. Stop trouble shooting here and repair the problem. When the repair is completed, completely retest the vehicle before lowering the drive wheels to the ground.

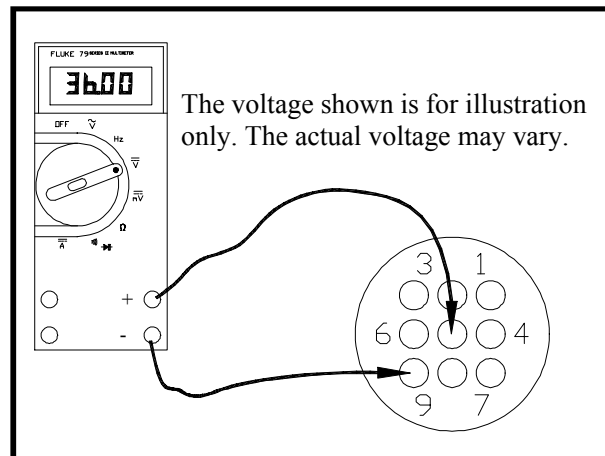



Connect a voltmeter between pin #9 (-) and pin #2 (+) in the test harness.

**Depress the accelerator pedal to engage MS-1 only.**

- If the voltage is between 6.0 and 6.5 volts and the test at the PMC #2 terminal in the Control Wire Input section failed then the wire or interlock switches between the accelerator module pin #2 and the PMC pin #2 is open. Stop trouble shooting here and repair the problem. When the repair is completed, completely retest the vehicle before lowering the drive wheels to the ground.
- If the voltage is not between 6.0 and 6.5 volts then the accelerator module has failed. Stop trouble shooting here and repair the problem. When the repair is completed, completely retest the vehicle before lowering the drive wheels to the ground.

**Now Depress the accelerator module fully.**

- If the voltage is not between 11.0 and 11.5 volts then the accelerator module has failed. Stop trouble shooting here and repair the problem. When the repair is completed, completely retest the vehicle before lowering the drive wheels to the ground.

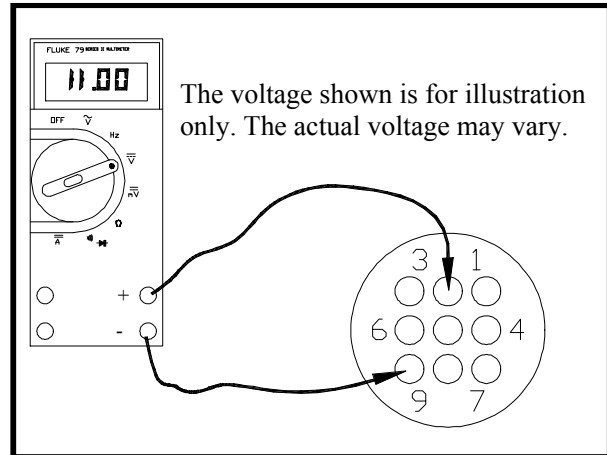

## STOP

Stop, do not continue. If you reached this point without a solution, then you may have an unanticipated problem or have made an error during testing. It is important to review the trouble shooting steps that have led to this point. The tests may need to be repeated.

## Key Switch

### **⚠ WARNING**

1. Make sure the key-switch is in the "OFF" position, then remove the key.
2. Place the forward-reverse switch in the center "OFF" position.
3. Set the park brake.
4. Place blocks under the front wheels to prevent vehicle movement.

### **⚠ WARNING**

The rear drive wheels may rotate during some of the following tests. Block the front wheels, raise the rear drive wheels off the ground, and support the vehicle with jack stands. Failure to do so may cause the vehicle to move and cause property damage and/or serious bodily injury.

### **⚠ WARNING**

Rotating rear drive wheels are a potential hazard. Keep hands, arms, legs and loose clothing away from the rear drive wheels while conducting tests. Failure to do so may cause serious bodily injury.

Test all interlock switches and/or interlock relays (if equipped) for continuity. Depending on the model of your vehicle, it may have a seat interlock, Foot interlock, Charger interlock, special order interlock or any combination of the above. Refer to the wire diagram at the end of this section for location of the interlocks.

*NOTE: Due to the many different configurations possible for special order interlocks, they will not be included in this text. Refer to the option list for your truck or contact your Taylor-Dunn® Representative for more information.*

If you do not know how to test for continuity, refer test to a qualified technician.

Connect a voltmeter across the HOT terminal of the key switch and battery negative.

- If the voltage is not at battery volts then check the wire between the key switch and battery positive. Stop trouble shooting here and repair the problem. When the repair is completed, completely retest the vehicle before lowering the drive wheels to the ground.

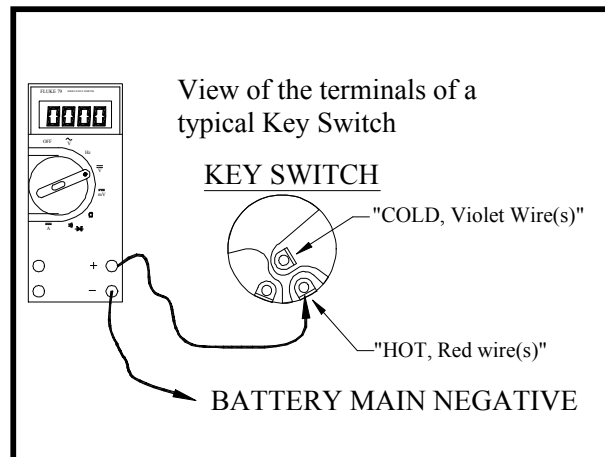



Connect a voltmeter across the COLD terminal of the key switch and battery negative.

**Turn the key switch ON.**

- If the voltage is not at battery volts then the key switch has failed. Stop trouble shooting here and repair the problem. When the repair is completed, completely retest the vehicle before lowering the drive wheels to the ground.
- If the voltage is at battery volts but the previous test at pin #4 in the Accelerator section failed then check the wire from the key switch to pin #4 at the accelerator module. Stop trouble shooting here and repair the problem. When the repair is completed, completely retest the vehicle before lowering the drive wheels to the ground.

For your reference, shown at the right are the Forward and Reverse switch wire connections for a typical control system.

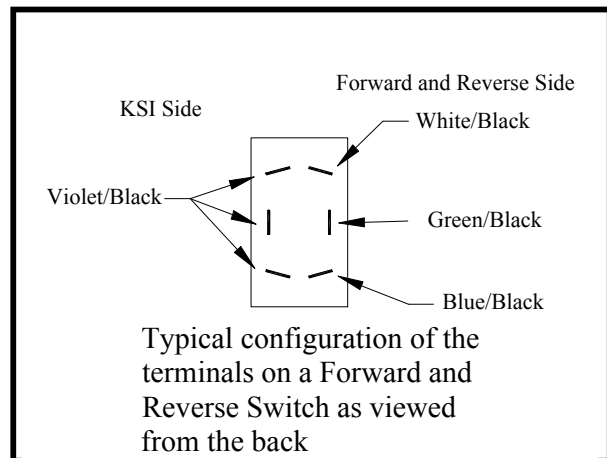
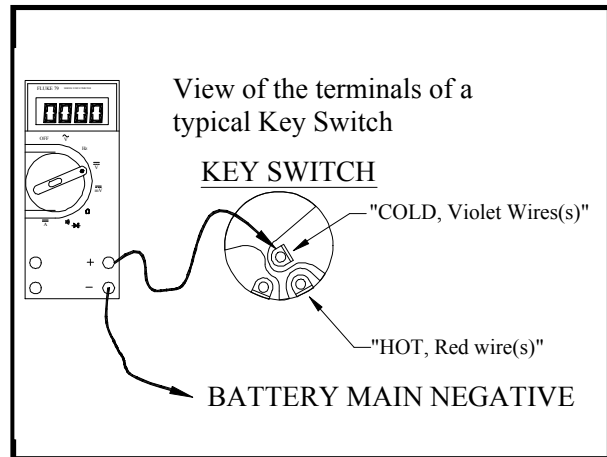

Connect a voltmeter across the HOT terminal of the KSI side of the F&R switch and battery negative.

**Turn the key switch ON.**

- If the voltage is not at battery volts then go to the Accelerator sequence.

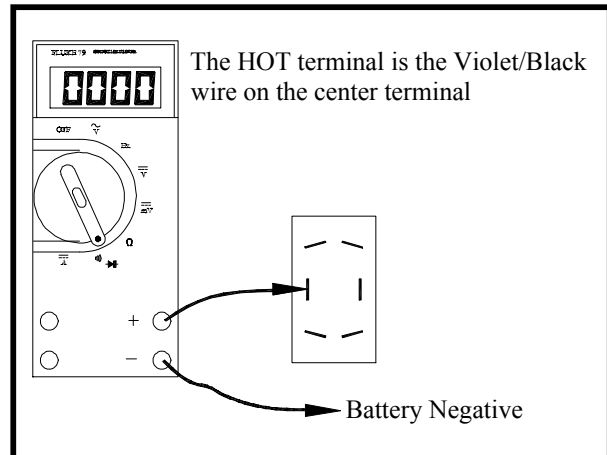



Connect a voltmeter across one of the COLD terminals of the KSI side of the F&R switch and battery negative.

**Close all interlock switches, turn the Key Switch ON, and place the F&R Switch in Forward.**

- If the voltage is not at battery volts then the F&R switch has failed. Stop trouble shooting here and repair the problem. When the repair is completed, completely retest the vehicle before lowering the drive wheels to the ground.
- If the voltage is at battery volts and the test at the PMC KSI terminal in the Control Wire Inputs section failed then check the wiring between COLD terminals of the KSI side of the F&R switch and the PMC KSI terminal. Stop trouble shooting here and repair the problem. When the repair is completed, completely retest the vehicle before lowering the drive wheels to the ground.

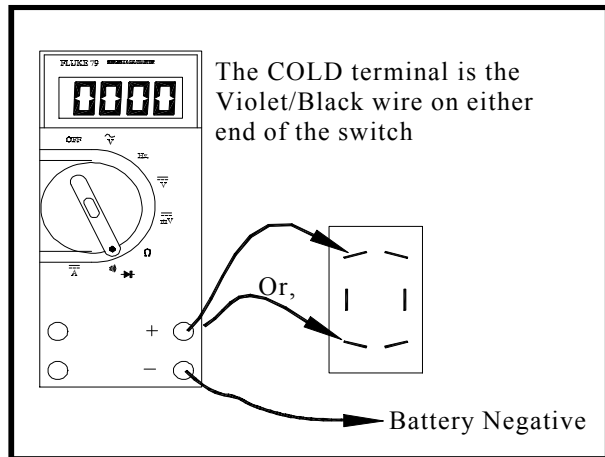

## F/R switch

### **⚠ WARNING**

1. Make sure the key-switch is in the "OFF" position, then remove the key.
2. Place the forward-reverse switch in the center "OFF" position.
3. Set the park brake.
4. Place blocks under the front wheels to prevent vehicle movement.

### **⚠ WARNING**

The rear drive wheels may rotate during some of the following tests. Block the front wheels, raise the rear drive wheels off the ground, and support the vehicle with jack stands. Failure to do so may cause the vehicle to move and cause property damage and/or serious bodily injury.

### **⚠ WARNING**

Rotating rear drive wheels are a potential hazard. Keep hands, arms, legs and loose clothing away from the rear drive wheels while conducting tests. Failure to do so may cause serious bodily injury.



Connect a voltmeter across the Solenoid Negative Buss Bar and battery positive.

**NOTE:** You may skip this test if it was completed in a previous section

- If the voltage is not at battery volts then check the wiring to battery negative and the negative circuit breaker. Stop trouble shooting here and repair the problem. When the repair is completed, completely retest the vehicle before lowering the drive wheels to the ground.

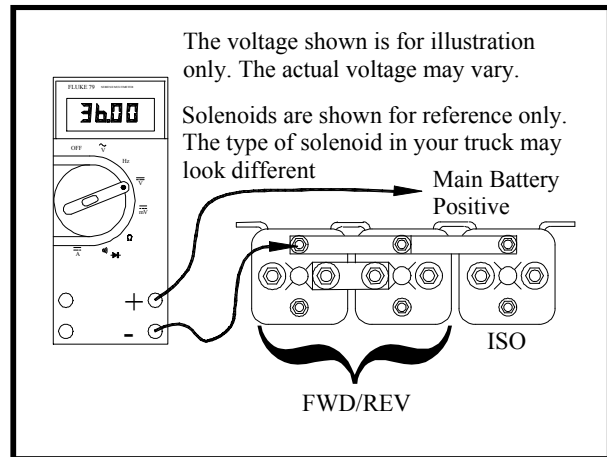

Connect a voltmeter across the center terminal of the forward and reverse side of the F&R switch and battery negative.

**Close all interlock switches, turn the Key Switch ON, and place the F&R Switch in Forward.**

**Depress the accelerator pedal fully.**

- If the voltage is not at battery volts then go to the **Accelerator** sequence.

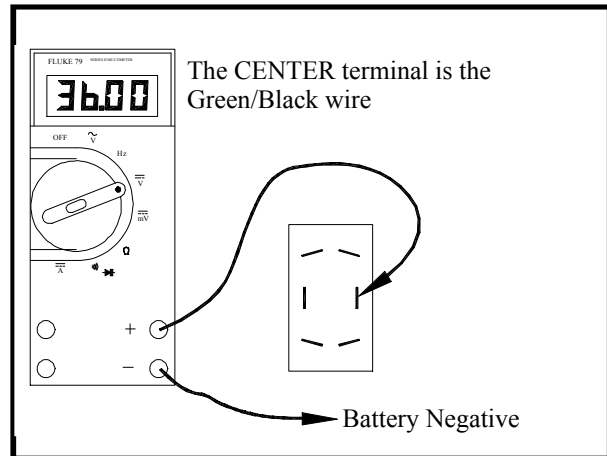

Connect a voltmeter across the forward terminal of the forward and reverse side of the F&R switch and battery negative.

**Close all interlock switches, turn the Key Switch ON, and place the F&R Switch in forward.**

**Depress the accelerator pedal fully.**

- If the voltage is not at battery volts then the F&R switch has failed. Stop trouble shooting here and repair the problem. When the repair is completed, completely retest the vehicle before lowering the drive wheels to the ground.

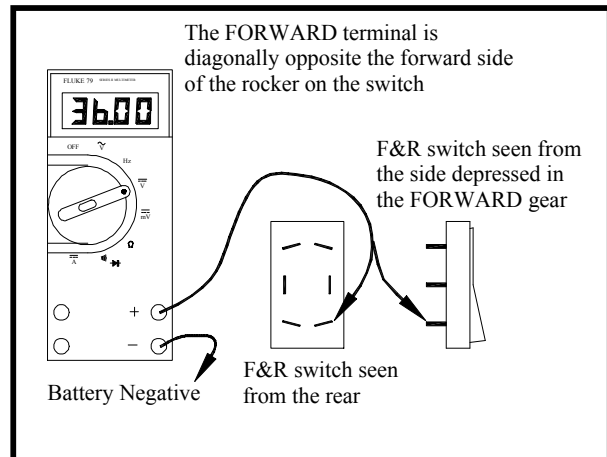

Connect a voltmeter across the reverse terminal of the forward and reverse side of the F&R switch and battery negative.

**Close all interlock switches, turn the Key Switch ON, and place the F&R Switch in reverse.**

**Depress the accelerator pedal fully.**

- If the voltage is not at battery volts then the F&R switch has failed. Stop trouble shooting here and repair the problem. When the repair is completed, completely retest the vehicle before lowering the drive wheels to the ground.
- If all tests in this section were good then check the wiring from the F&R switch to the Forward and Reverse solenoids and both the forward and reverse solenoid coils. Stop trouble shooting here and repair the problem. When the repair is completed, completely retest the vehicle before lowering the drive wheels to the ground.

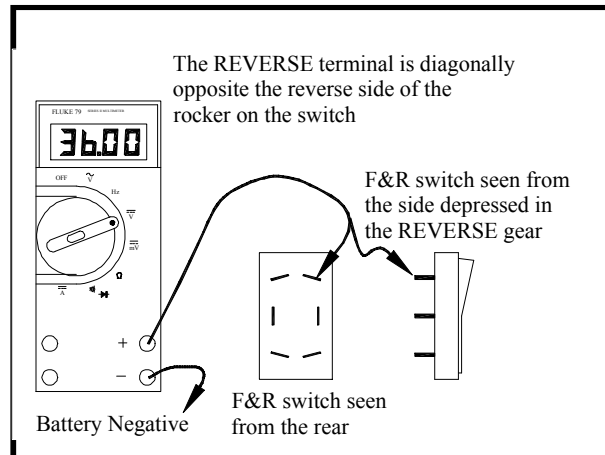

## Solenoids

### **⚠ WARNING**

1. Make sure the key-switch is in the "OFF" position, then remove the key.
2. Place the forward-reverse switch in the center "OFF" position.
3. Set the park brake.
4. Place blocks under the front wheels to prevent vehicle movement.

### **⚠ WARNING**

The rear drive wheels may rotate during some of the following tests. Block the front wheels, raise the rear drive wheels off the ground, and support the vehicle with jack stands. Failure to do so may cause the vehicle to move and cause property damage and/or serious bodily injury.

### **⚠ WARNING**

Rotating rear drive wheels are a potential hazard. Keep hands, arms, legs and loose clothing away from the rear drive wheels while conducting tests. Failure to do so may cause serious bodily injury.

If the vehicle runs in forward only then skip ahead to the test sequence **Forward (does not run in reverse)**.

If the vehicle runs in reverse only then skip ahead to the test sequence **Reverse (does not run in forward)**.



# ELECTRICAL TROUBLESHOOTING

Connect a voltmeter across the ISO solenoid COLD terminal and battery negative.

**Close all interlock switches and turn the Key Switch ON.**

**Depress the accelerator pedal fully.**

- If the voltage is at battery volts then the wire from the ISO solenoid to the PMC is bad. Stop trouble shooting here and repair the problem. When the repair is completed, completely retest the vehicle before lowering the drive wheels to the ground.

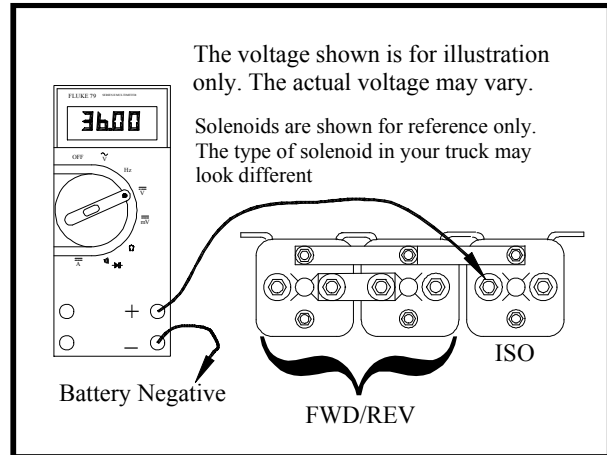

Connect a voltmeter across the ISO solenoid HOT terminal and battery negative.

**Close all interlock switches and turn the Key Switch ON.**

**Depress the accelerator pedal fully.**

- If the voltage is at battery volts then the ISO solenoid has failed. Stop trouble shooting here and repair the problem. When the repair is completed, completely retest the vehicle before lowering the drive wheels to the ground.
- If the voltage is not at battery volts then check the wiring to battery positive and the main circuit breaker. Stop trouble shooting here and repair the problem. When the repair is completed, completely retest the vehicle before lowering the drive wheels to the ground.

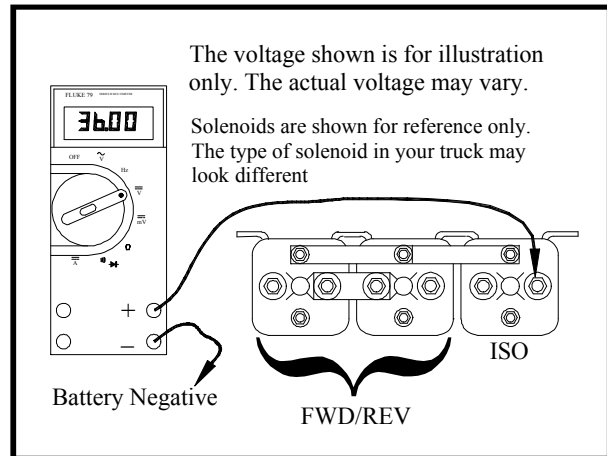

## **Forward (does not run in reverse)**

Connect a voltmeter across the PMC KSI terminal and battery negative.

**Close all interlock switches, turn the Key Switch ON, and place the F&R Switch in reverse.**

- If the voltage is not at battery volts then go to the **Key Switch** sequence.

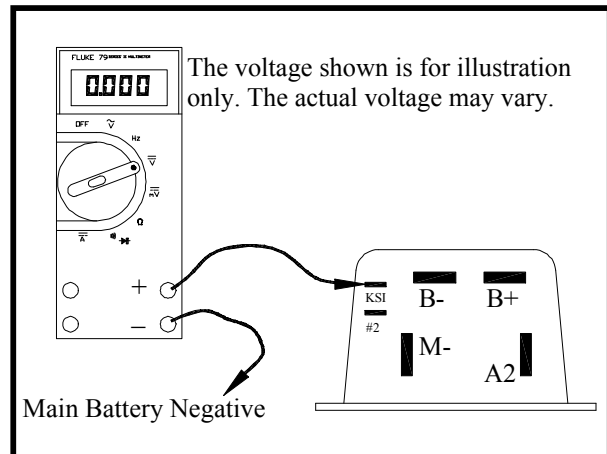

Connect a voltmeter across the Reverse Solenoid coil terminals. Refer to your vehicles wiring diagram to identify the position of the reverse solenoid.

**Close all interlock switches, turn the Key Switch ON, and place the F&R Switch in reverse.**

**Depress the accelerator pedal fully.**

- If the voltage is not at battery volts then go to the **F/R Switch** sequence.

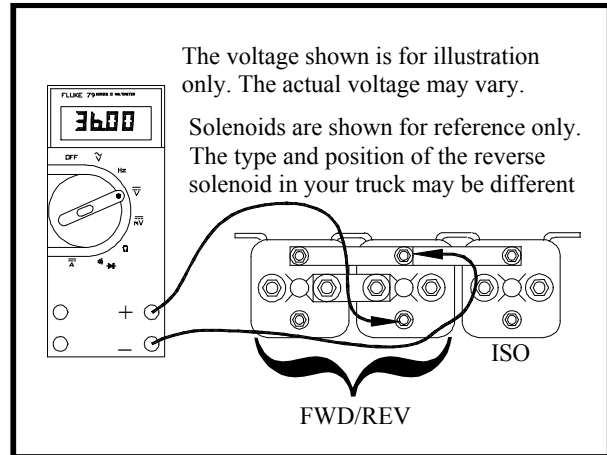

Set the test light voltage to the same voltage as the battery volts.

Connect the test light across the normally open contacts of the reverse solenoid. Refer to your vehicles wiring diagram to identify the position of the reverse solenoid.

**Close all interlock switches, turn the Key Switch ON, and place the F&R Switch in reverse.**

**Depress the accelerator pedal fully.**

- If the light comes on then the Reverse solenoid has failed. Stop trouble shooting here and repair the problem. When the repair is completed, completely retest the vehicle before lowering the drive wheels

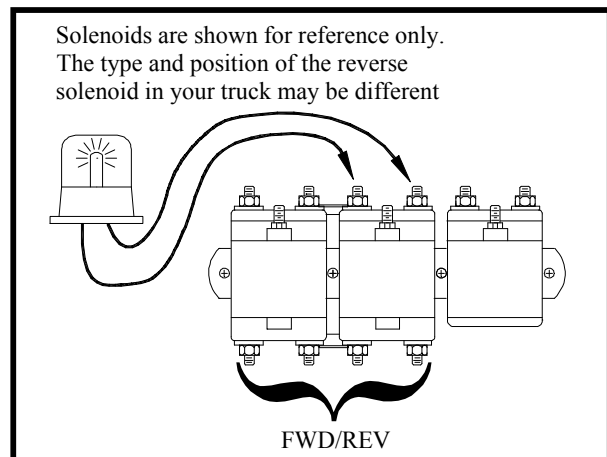

to the ground.

Connect the test light across the Normally Closed contacts of the Forward solenoid. Refer to your vehicles wiring diagram to identify the position of the forward solenoid.

**Close all interlock switches, turn the Key Switch ON, and place the F&R Switch in Reverse.**

**Depress the accelerator pedal fully.**

- If the light comes on then the Forward solenoid has failed. Stop trouble shooting here and repair the problem. When the repair is completed, completely retest the vehicle before lowering the drive wheels to the ground.

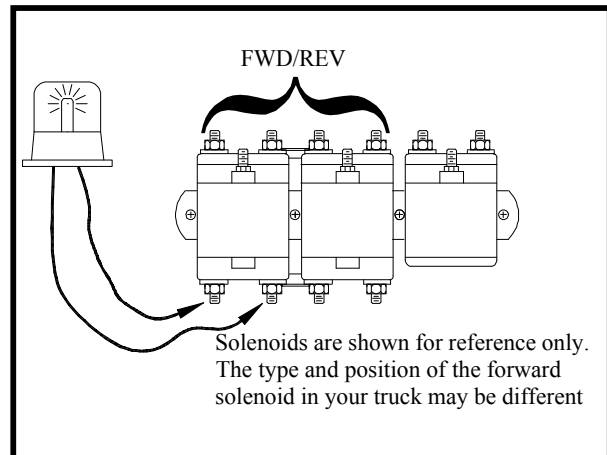

## STOP

Stop, do not continue. If you reached this point without a solution, then you may have an unanticipated problem or have made an error during testing. It is important to review the trouble shooting steps that have led to this point. The tests may need to be repeated.



## Reverse (does not run in forward)

Connect a voltmeter across the PMC KSI terminal and battery negative.

**Close all interlock switches, turn the Key Switch ON, and place the F&R Switch in forward.**

- If the voltage is not at battery volts then go to the **Key Switch** sequence.

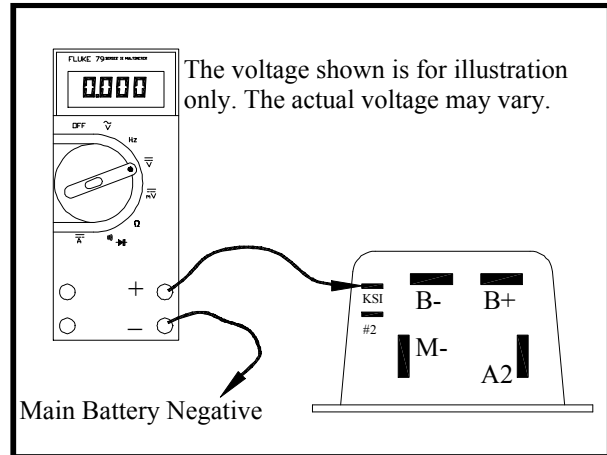

Connect a voltmeter across the Forward Solenoid coil terminals. Refer to your vehicles wiring diagram to identify the position of the forward solenoid.

**Close all interlock switches, turn the Key Switch ON, and place the F&R Switch in forward.**

**Depress the accelerator pedal fully.**

- If the voltage is not at battery volts then go to the **F/R Switch** sequence.

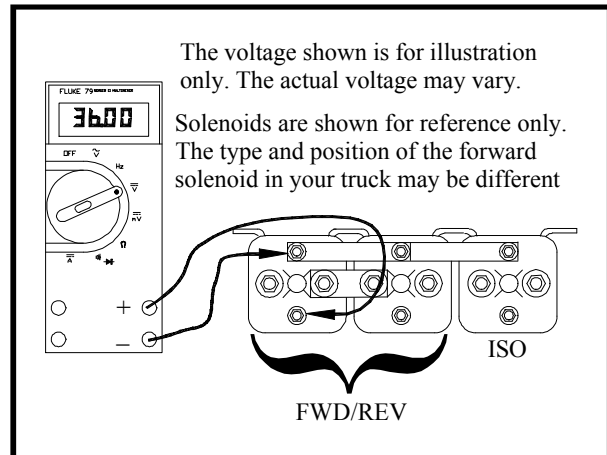

Set the test light voltage to the same voltage as the battery volts.

Connect the test light across the Normally Open contacts of the Forward solenoid. Refer to your vehicles wiring diagram to identify the position of the forward solenoid.

**Close all interlock switches, turn the Key Switch ON, and place the F&R Switch in forward.**

**Depress the accelerator pedal fully.**

- If the light comes on then the Forward solenoid has failed. Stop trouble shooting here and repair the problem. When the repair is completed, completely retest the vehicle before lowering the drive wheels to the ground.

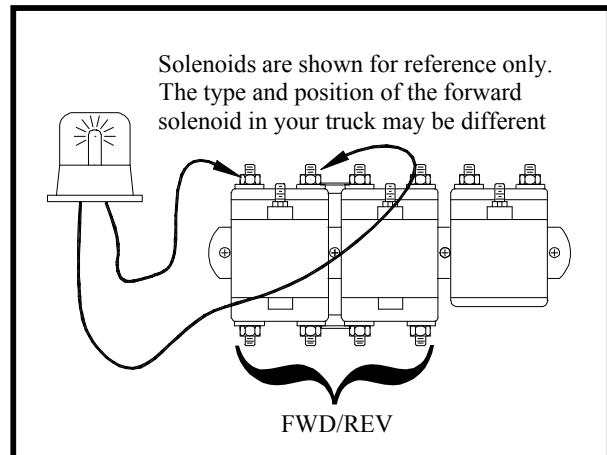



Set the test light voltage to the same voltage as the battery volts.

Connect the test light across the Normally Closed contacts of the Reverse solenoid. Refer to your vehicles wiring diagram to identify the position of the Reverse solenoid.

**Close all interlock switches, turn the Key Switch ON, and place the F&R Switch in Forward.**

**Depress the accelerator pedal fully.**

- If the light comes on then the Reverse solenoid has failed. Stop trouble shooting here and repair the problem. When the repair is completed, completely retest the vehicle before lowering the drive wheels to the ground.

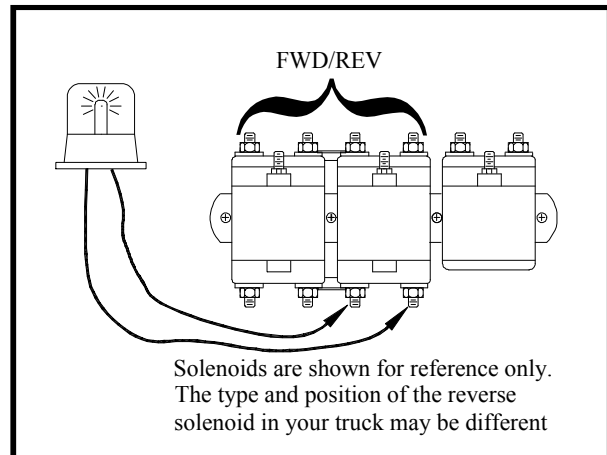

## STOP

Stop, do not continue. If you reached this point without a solution, then you may have an unanticipated problem or have made an error during testing. It is important to review the trouble shooting steps that have led to this point. The tests may need to be repeated.



*B2-48 With Dump Bed Option*



*B2-10 Ambulance*



*B2-48 with Steel Cab, Foldaway  
4-Passenger Seat and Stake Sides*



*P2-50 30,000 Pound Tow Tractor*



*ET 3000*



*ET1-50 Full Size Truck*



## **Section 4A**

### **Vehicle Wire Diagrams**

---

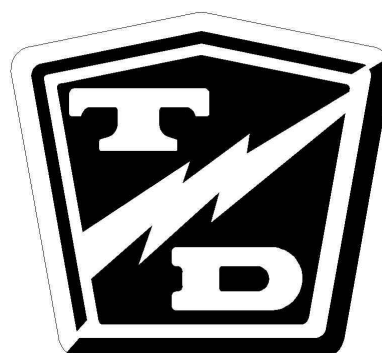



# ELECTRICAL TROUBLESHOOTING

## Model SS 5-34, SS 5-36 abd SS 5-46 with the Dual Chassis Harness

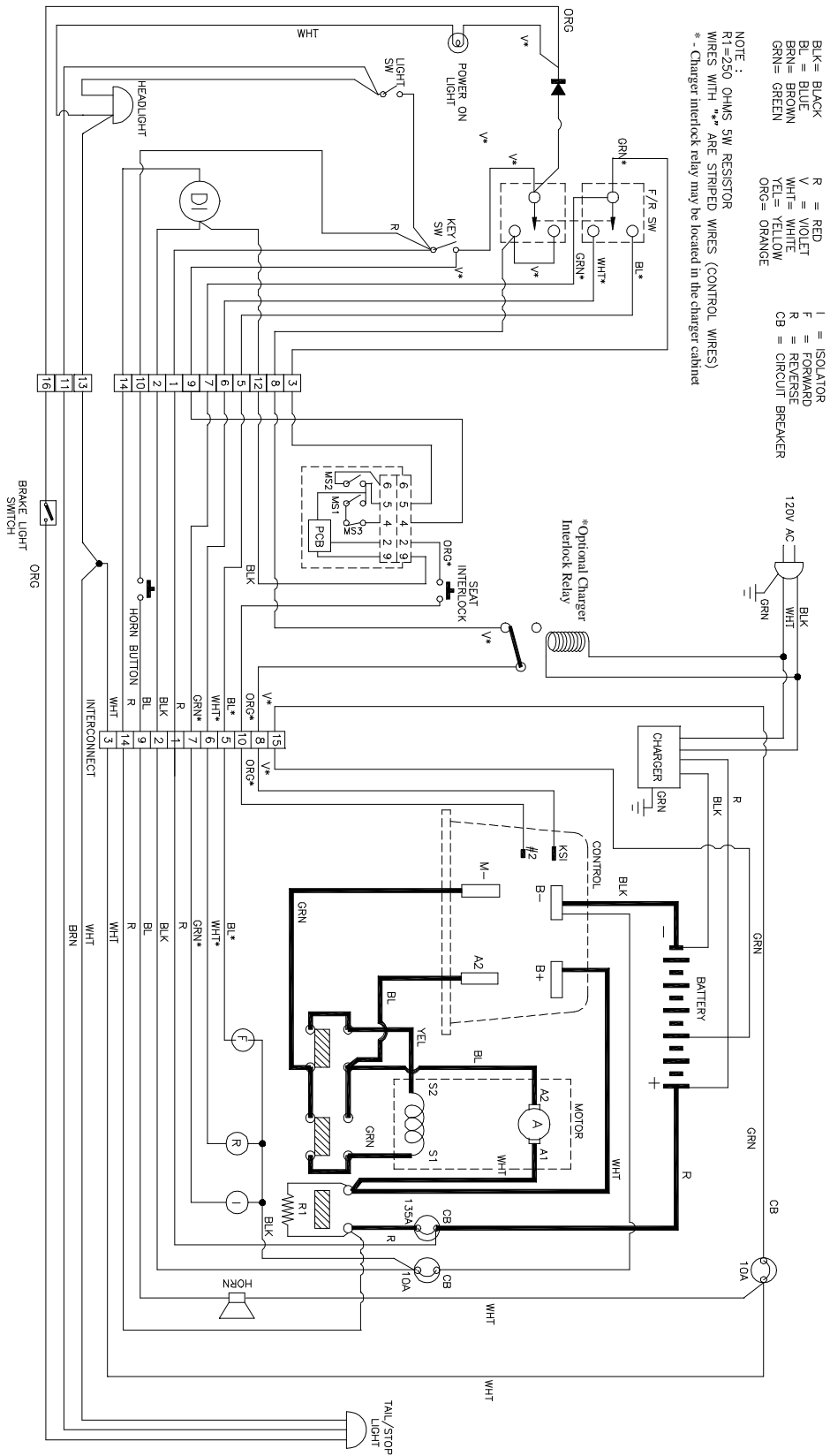



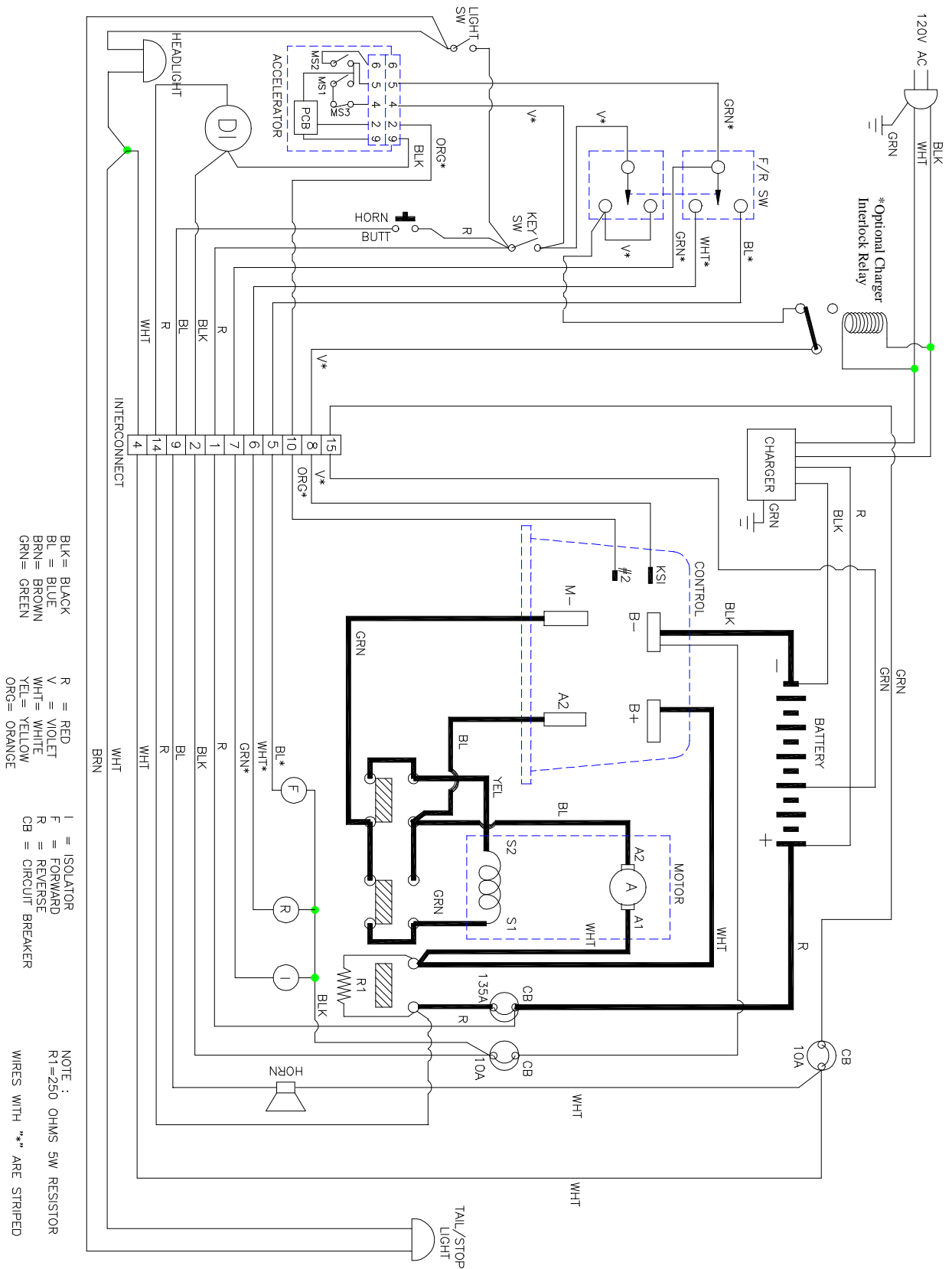

**Model SS 5-34 with the Single Chassis Harness**

## Section 4-Special Troubleshooting Guide

This section is specific to the symptoms listed below. Each troubleshooting sequence assumes that all listed symptoms are present. Do not use this section unless the truck has all listed symptoms.

<b>SYMPTOMS</b>		<b>GO TO</b>
➤	Runs slow in both directions plus high armature and field current in both directions. NOTE: Armature and field current should be equal.	MOTOR
➤	Runs slow in both directions plus high armature current in both directions. NOTE: Field current will be very low.	SOLENOIDS
➤	Runs normal in one direction only plus runs slow or lacks power in the opposite direction with high armature current in the opposite direction or;  Accelerates slowly and exceeds normal speed in the opposite direction with high armature current only. NOTE: Field current will be very low in the opposite direction.	SOLENOIDS
➤	Accelerates slowly and exceeds normal speed in both directions plus high armature current. NOTE: Field current will be very low.	SOLENOIDS
➤	Full speed only.	PMC CONTROL
➤	Does not run in either direction plus there is noise from motor (hum or whine) with high field current and low armature current.	PLUGGING DIODE
➤	Excessive spark when connecting battery	ISO
➤	Does not run or runs very slow with low motor current and high battery current.	FREEWHEEL DIODE
➤	Jumps into high speed when direction is selected after depressing the accelerator pedal.	HPD

### Section 4, Special Troubleshooting Table of Contents

PMC CONTROL -----	2
PLUGGING DIODE -----	4
FREEWHEEL DIODE -----	5
ISO -----	6
SOLENOIDS -----	8
MOTOR -----	11



## ⚠ WARNING

1. Make sure the key-switch is in the "OFF" position, then remove the key.
2. Place the forward-reverse switch in the center "OFF" position.
3. Set the park brake.
4. Place blocks under the front wheels to prevent vehicle movement.
5. Disconnect the main positive and negative cables at the batteries.

## ⚠ WARNING

The rear drive wheels may rotate during some of the following tests. Block the front wheels, raise the rear drive wheels off the ground, and support the vehicle with jack stands. Failure to do so may cause the vehicle to move and cause property damage and/or serious bodily injury.

## ⚠ WARNING

Rotating rear drive wheels are a potential hazard. Keep hands, arms, legs and loose clothing away from the rear drive wheels while conducting tests. Failure to do so may cause serious bodily injury.

## PMC CONTROL

Disconnect the wire from the 'M-' terminal on the PMC control and tape it off to prevent electrical contact. Connect a volt meter across the PMC #2 terminal and battery negative.

**Turn the key-switch on, close all interlock switches (if equipped), depress the accelerator pedal to engage the first micro switch only (creep speed), then perform the following tests:**

- The meter reading should be between 6 and 6.5 volts.
- If the voltage at pin #2 is not 6 to 6.5 volts, then go to the **ACCELERATOR** sequence in the Main Troubleshooting Sequence, otherwise continue with the next test.

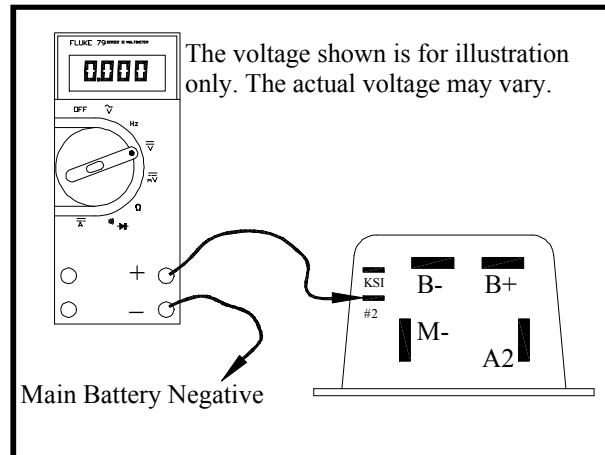



Connect a volt meter across the PMC B+ and PMC M- terminals.

**Turn the key-switch on, close all interlock switches (if equipped), depress the accelerator pedal to engage the first micro switch only (creep speed), then perform the following tests:**

- The meter reading should not be equal to the battery voltage.
- If you have full battery voltage then the PMC control is shorted and must be replaced. Stop trouble shooting here and repair the problem. When the repair is completed, completely retest the vehicle before lowering the drive wheels to the ground, otherwise continue with the next test.

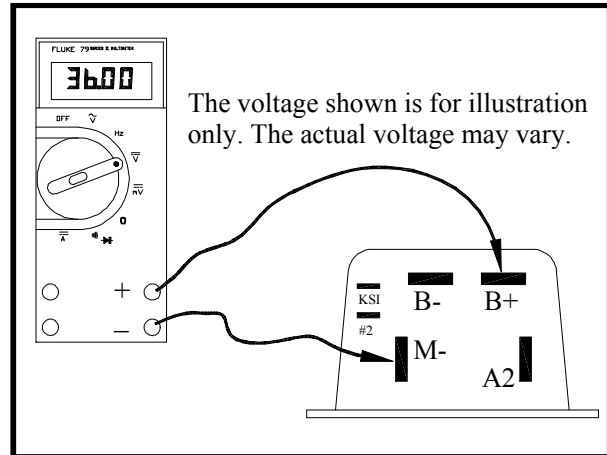

If the voltage at pin #2 is correct and the voltage at 'M-' is correct, then there is a short in the harness between the wire connected to the PMC 'M-' and main battery negative. Stop trouble shooting here and repair the problem. When the repair is completed, completely retest the vehicle before lowering the drive wheels to the ground.

## STOP

Stop, do not continue. If you reached this point without a solution, then you may have an unanticipated problem or have made an error during testing. It is important to review the trouble shooting steps that have led to this point. The tests may need to be repeated.





## PLUGGING DIODE

### **⚠ WARNING**

1. Make sure the key-switch is in the "OFF" position, then remove the key.
2. Place the forward-reverse switch in the center "OFF" position.
3. Set the park brake.
4. Place blocks under the front wheels to prevent vehicle movement.
5. Disconnect the main positive and negative cables at the batteries.

### **⚠ WARNING**

The rear drive wheels may rotate during some of the following tests. Block the front wheels, raise the rear drive wheels off the ground, and support the vehicle with jack stands. Failure to do so may cause the vehicle to move and cause property damage and/or serious bodily injury.

### **⚠ WARNING**

Rotating rear drive wheels are a potential hazard. Keep hands, arms, legs and loose clothing away from the rear drive wheels while conducting tests. Failure to do so may cause serious bodily injury.

Remove the wires from the 'B+' and 'A2' terminals on the PMC control and perform the following test:

Using the diode test function on the DMM check for the presence of a diode across 'B+' and 'A2' on the PMC control..

If you do not know how to test for a diode, refer test to a qualified technician.

- If the diode is open or shorted, then the PMC control must be replaced. Stop trouble shooting here and repair the problem. When the repair is completed, completely retest the vehicle before lowering the drive wheels to the ground.

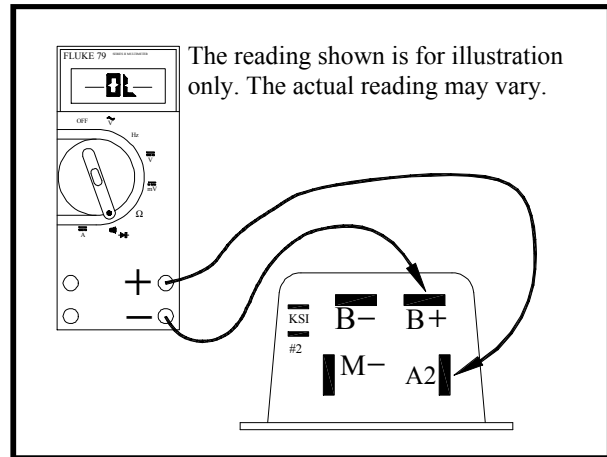

## STOP

Stop, do not continue. If you reached this point without a solution, then you may have an unanticipated problem or have made an error during testing. It is important to review the trouble shooting steps that have led to this point. The tests may need to be repeated.



## FREEWHEEL DIODE

### **⚠ WARNING**

1. Make sure the key-switch is in the "OFF" position, then remove the key.
2. Place the forward-reverse switch in the center "OFF" position.
3. Set the park brake.
4. Place blocks under the front wheels to prevent vehicle movement.
5. Disconnect the main positive and negative cables at the batteries.

### **⚠ WARNING**

The rear drive wheels may rotate during some of the following tests. Block the front wheels, raise the rear drive wheels off the ground, and support the vehicle with jack stands. Failure to do so may cause the vehicle to move and cause property damage and/or serious bodily injury.

### **⚠ WARNING**

Rotating rear drive wheels are a potential hazard. Keep hands, arms, legs and loose clothing away from the rear drive wheels while conducting tests. Failure to do so may cause serious bodily injury.

Remove the wires from the 'B+' and 'M-' terminals on the PMC control and perform the following test:

Using the diode test function on the DMM check for the presence of a diode across 'B+' and 'M-' on the PMC control. Refer to Diode Figure 2.

If you do not know how to test for a diode, refer test to a qualified technician.

- If the diode is open or shorted, then the PMC control must be replaced. Stop trouble shooting here and repair the problem. When the repair is completed, completely retest the vehicle before lowering the drive wheels to the ground.

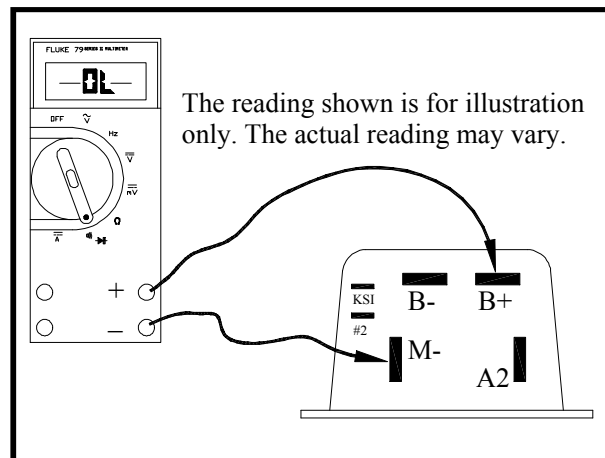

## **STOP**

Stop, do not continue. If you reached this point without a solution, then you may have an unanticipated problem or have made an error during testing. It is important to review the trouble shooting steps that have led to this point. The tests may need to be repeated.



## ISO

### **⚠ WARNING**

1. Make sure the key-switch is in the "OFF" position, then remove the key.
2. Place the forward-reverse switch in the center "OFF" position.
3. Set the park brake.
4. Place blocks under the front wheels to prevent vehicle movement.
5. Disconnect the main positive and negative cables at the batteries.

### **⚠ WARNING**

The rear drive wheels may rotate during some of the following tests. Block the front wheels, raise the rear drive wheels off the ground, and support the vehicle with jack stands. Failure to do so may cause the vehicle to move and cause property damage and/or serious bodily injury.

### **⚠ WARNING**

Rotating rear drive wheels are a potential hazard. Keep hands, arms, legs and loose clothing away from the rear drive wheels while conducting tests. Failure to do so may cause serious bodily injury.

Remove the wires and the resistor from the ISO solenoid and perform the following tests:

Test continuity across the ISO power contacts.

If you do not know how to test for continuity, refer test to a qualified technician.

- This should be an open circuit. If it is not an open circuit then the contactor should be replaced. Stop trouble shooting here and repair the problem. When the repair is completed, completely retest the vehicle before lowering the drive wheels to the ground, other wise continue to the next test.

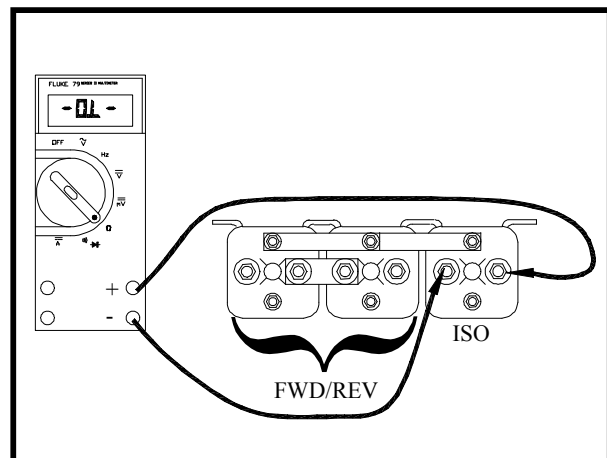



Connect the meter to each end of the resistor that was removed from the ISO solenoid and measure its resistance.

- The meter reading should be 250 Ohms (+/-10%). If it is not 250 ohms (+/-10%), then replace the resistor. Stop trouble shooting here and repair the problem. When the repair is completed, completely retest the vehicle before lowering the drive wheels to the ground.

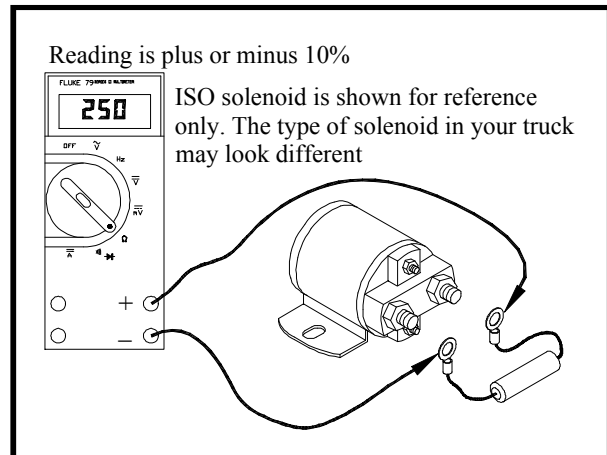

## STOP

Stop, do not continue. If you reached this point without a solution, then you may have an unanticipated problem or have made an error during testing. It is important to review the trouble shooting steps that have led to this point. The tests may need to be repeated.





## SOLENOIDS

There is a very slight possibility that a failure in the motor could cause these symptoms. Perform the tests covered in the MOTOR section first. If the motor is OK, continue with the following tests.

### ⚠ WARNING

1. Make sure the key-switch is in the "OFF" position, then remove the key.
2. Place the forward-reverse switch in the center "OFF" position.
3. Set the park brake.
4. Place blocks under the front wheels to prevent vehicle movement.
5. Disconnect the main positive and negative cables at the batteries.

### ⚠ WARNING

The rear drive wheels may rotate during some of the following tests. Block the front wheels, raise the rear drive wheels off the ground, and support the vehicle with jack stands. Failure to do so may cause the vehicle to move and cause property damage and/or serious bodily injury.

### ⚠ WARNING

Rotating rear drive wheels are a potential hazard. Keep hands, arms, legs and loose clothing away from the rear drive wheels while conducting tests. Failure to do so may cause serious bodily injury.

Remove the wires from the 'S1' and 'S2' terminals on the motor. Remove the wire from the 'M-' terminal on the PMC control. Make sure none of these wires can come into electrical contact with the frame or any other wire.

Reconnect the batteries.

**With the key-switch on and the forward and reverse switch in neutral, perform the following tests:**

- Check continuity from the motor 'A2' terminal to the wire that was connected to the motor 'S1' terminal. DO NOT make this test to the 'S1' terminal, just the wire. Refer to Solenoid Figure 1.

If you do not know how to test for continuity, refer test to a qualified technician.

- This should be an open circuit, if it reads as a short, then one of the following has occurred:

- A) The reverse solenoid is shorted.
- B) The wire connected to the motor 'S1' terminal is shorted to the wire connected to the motor 'A2' terminal.
- C) The wire connected to the motor 'S1' terminal is shorted to the wire connected to the PMC 'A2' terminal.

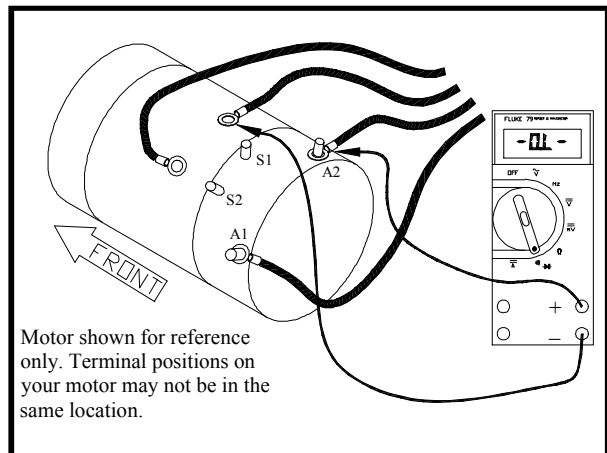

Stop trouble shooting here and repair the problem. When the repair is completed, completely retest the vehicle before lowering the drive wheels to the ground, otherwise continue with the next test.

- Check continuity from the motor 'A2' terminal to the wire that was connected to the motor 'S2' terminal. DO NOT make this test to the 'S2' terminal, just the wire.

If you do not know how to test for continuity, refer test to a qualified technician.

- This should read as an open circuit. If it reads as a short then one of the following has occurred:
  - A) The forward solenoid is shorted.
  - B) The wire connected to the motor 'S2' terminal is shorted to the wire connected to the motor 'A2' terminal.
  - C) The wire connected to the motor 'S2' terminal is shorted to the wire connected to the PMC 'A2' terminal.

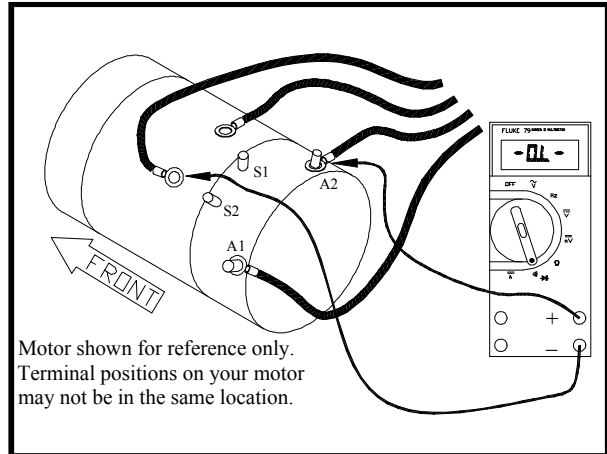

Stop trouble shooting here and repair the problem. When the repair is completed, completely retest the vehicle before lowering the drive wheels to the ground, otherwise continue with the next test.

**With the key-switch on and the F&R switch in forward, depress the accelerator pedal and perform the following tests:**

- Check continuity from the wire that was connected to the PMC 'M-' terminal to the wire that was connected to the motor 'S2' terminal.

If you do not know how to test for continuity, refer test to a qualified technician.

- This should read as an open circuit. If it reads as a short, then one of the following has occurred:
  - A) The forward solenoid is shorted.
  - B) The wire connected to the PMC 'M-' terminal is shorted to the wire connected to the motor 'S2' terminal.

Stop trouble shooting here and repair the problem. When the repair is completed, completely retest the vehicle before lowering the drive wheels to the ground, otherwise continue with the next test.

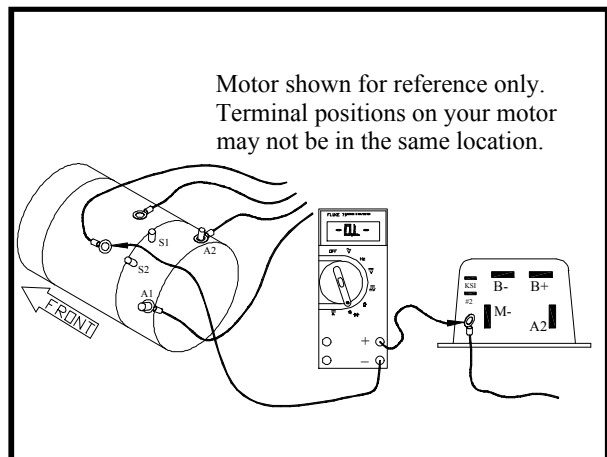



# ELECTRICAL TROUBLESHOOTING

With the key-switch on and the F&R switch in reverse, depress the accelerator pedal and perform the following tests:

- Check continuity from the wire that was connected to the PMC 'M-' terminal to the wire that was connected to the motor 'S1' terminal.

If you do not know how to test for continuity, refer test to a qualified technician.

- This should read as an open circuit. If it reads as a short, then one of the following has occurred:
  - A) The reverse solenoid is shorted.
  - B) The wire connected to the PMC 'M-' terminal is shorted to the wire connected to the motor 'S1' terminal.

Stop trouble shooting here and repair the problem. When the repair is completed, completely retest the vehicle before lowering the drive wheels to the ground

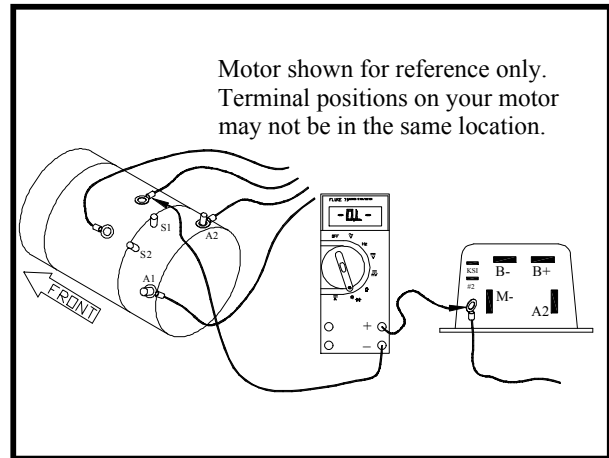

---

---

## STOP

---

---

Stop, do not continue. If you reached this point without a solution, then you may have an unanticipated problem or have made an error during testing. It is important to review the trouble shooting steps that have led to this point. The tests may need to be repeated.

---

---

## MOTOR

High motor current in both the field and the armature, accompanied with a lack of power, would indicate a shorted armature and/or field.

Another symptom that may exist is jumping or stuttering at low speeds and/or the motor will not run unless the armature is manually rotated. If this symptom exists, it indicates that there may be open segments in the armature. Visually inspect the brushes, if they are OK, continue with the testing below.

### **⚠ WARNING**

1. Make sure the key-switch is in the "OFF" position, then remove the key.
2. Place the forward-reverse switch in the center "OFF" position.
3. Set the park brake.
4. Place blocks under the front wheels to prevent vehicle movement.
5. Disconnect the main positive and negative cables at the batteries.

### **⚠ WARNING**

The rear drive wheels may rotate during some of the following tests. Block the front wheels, raise the rear drive wheels off the ground, and support the vehicle with jack stands. Failure to do so may cause the vehicle to move and cause property damage and/or serious bodily injury.

### **⚠ WARNING**

Rotating rear drive wheels are a potential hazard. Keep hands, arms, legs and loose clothing away from the rear drive wheels while conducting tests. Failure to do so may cause serious bodily injury.

Disconnect the four motor wires and perform the following tests:

Check continuity from 'A1' to the frame of the motor..

If you do not know how to test for continuity, refer test to a qualified technician.

- This should be an open circuit. If there is continuity from 'A1' to the frame of the motor, then the motor armature or armature circuit (brushes) are shorted. Stop trouble shooting here and repair the problem. When the repair is completed, completely retest the vehicle before lowering the drive wheels to the ground, otherwise continue with the next test.

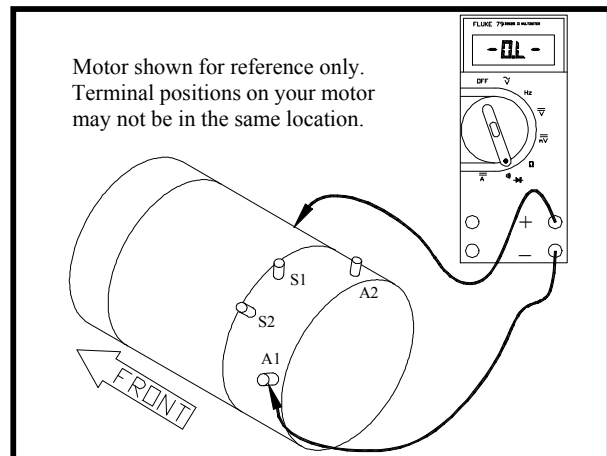



Check continuity from 'S1' to the frame of the motor.

If you do not know how to test for continuity, refer test to a qualified technician.

This should be an open circuit. If there is continuity from 'S1' to the frame of the motor, then the motor field is shorted. Stop trouble shooting here and repair the problem. When the repair is completed, completely retest the vehicle before lowering the drive wheels to the ground, otherwise continue to Motor Inspection.

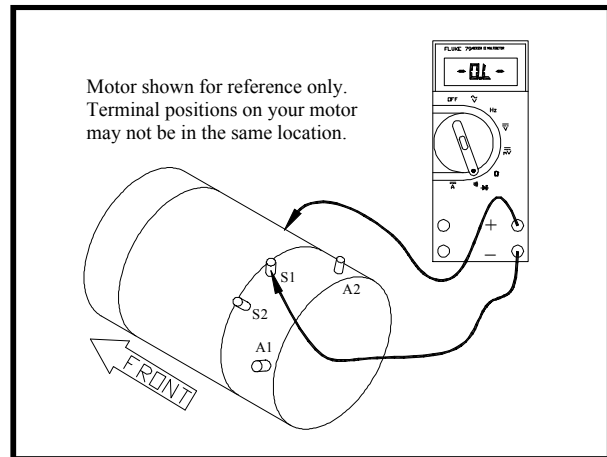

## Motor Inspection

1. Remove and disassemble the motor.
2. Visually inspect the inside of the brush end housing. If there are any silver specs of metal around the inside of the housing, it indicates that the armature has overheated and melted the solder around the commutator. The armature is bad and the motor must be replaced. Stop here and repair the problem, otherwise continue with the next test.
3. Visually inspect the armature wires where they loop around at the shaft end of the armature. The insulation should be a light to medium reddish brown color. If the insulation is dark brown to black or the insulation is cracked and peeling, then the armature has been overheated and burnt. The motor must be replaced. Stop here and repair the problem, otherwise continue with the next test.
4. Perform a continuity test around the armature commutator. Place one of the test leads on a single commutator segment. While holding the first test lead on the segment, check the continuity to the other segments around the commutator.

If you do not know how to test for continuity, refer test to a qualified technician.

- There should be continuity on each commutator segment. If an open segment is found, the armature is bad and the motor must be replaced. Stop trouble shooting here and repair the problem. When the repair is completed, completely retest the vehicle before lowering the drive wheels to the ground.

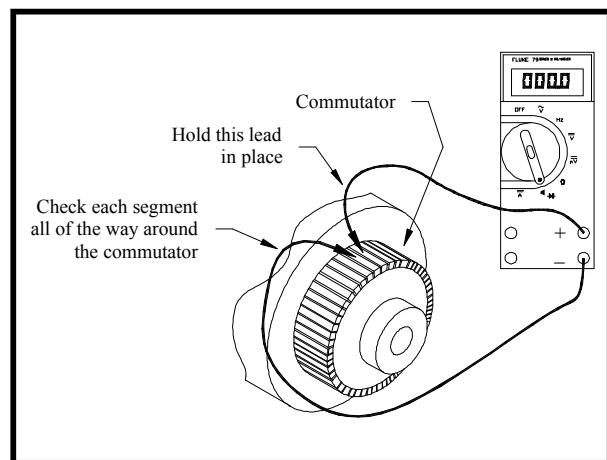

## STOP

Stop, do not continue. If you reached this point without a solution, then you may have an unanticipated problem or have made an error during testing. It is important to review the trouble shooting steps that have led to this point. The tests may need to be repeated.



## **SECTION 4b-Lestronic II Charger Troubleshooting**

---

### **Table of Contents for Lestronic II Charger Troubleshooting**

Operating Instructions and Theory of Operation .....	2
Testing the Charging Cycle .....	3
Test Equipment Required for Troubleshooting .....	4
Important Notes and Instructions .....	4
Troubleshooting for Built-in Charger .....	5
Troubleshooting for Portable Charger .....	8
Testing The Timer Relay .....	9
Testing the Interlock Relay .....	10

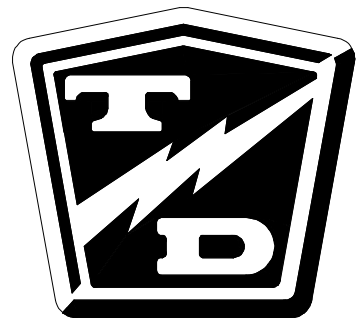

## Operating Instructions and Theory of Operation

The Lestronic II chargers are designed as semiautomatic chargers. The Lestronic II charger turns itself on when the “built-in” charger is plugged into the wall outlet, or when the “portable” charger is plugged into the batteries. As the battery charges, the battery voltage rises. The charger periodically checks the battery voltage and compares it to the previous reading. When the battery voltage stops rising a predetermined amount, then the batteries are no longer accepting a charge and the charger shuts off. The charger will not start again unless the AC cord on a “built-in” charger is disconnected from the wall outlet, or the DC plug on a portable charger is disconnected from the batteries.

The charger does not check the current state of charge when it is plugged in, it assumes that the batteries require charging when it is connected. For this reason, it is recommended to discharge the batteries approximately 50% (1175-1200 as indicated on a hydrometer) before connecting the charger. If the charger is connected before the batteries are discharged 50%, the batteries may enter an overcharge state before the charger can sense that the batteries are no longer accepting a charge. This could result in overcharging and and damaging the batteries.

The relay that operates the charger is powered by the batteries being charged. If the voltage on the batteries to be charged is less than approximately 65% of the rated charger DC voltage, the relay will not pick up and the charger will not turn on. In this situation, a manual charger would have to be used to bring the battery voltage up so that the Lestronic charger can sense that they are connected and turn itself on.

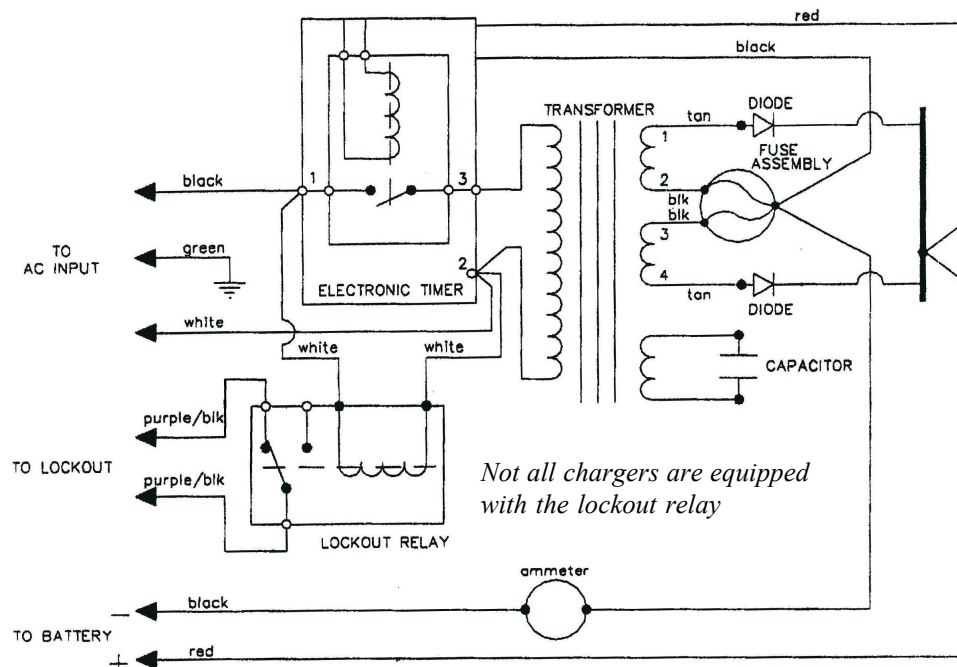

*Typical Charger Internal Wire Diagram*

## *Testing the Charging Cycle*

In typical installations, the charger will remain on for up to 12 hours depending on the state of charge of the battery when the charge cycle was started.

A charger could remain on for longer than 12 hours if:

- The charging cycle is interrupted at any time during the charging cycle.
- Defective batteries causing a fluctuating DC voltage that confuses the charger.
- A brownout (drop in AC line voltage) during the charging cycle.
- An electrically noisy charging environment.

A charger could turn off in less than 12 hours, but still show symptoms of overcharging if:

- The batteries were not discharged to 50% before connecting the charger.
- The electrolyte in the batteries is too high (boil over).
- The electrolyte in the batteries is too low (excessive gassing or sulfur smell).

To test the charger to see if it is turning off correctly, monitor the battery voltage and the electrolyte specific gravity during the charging cycle as indicated below.

### *Specific Gravity*

Using a hydrometer take the specific gravity reading of several cells, at 1 hour intervals while charging. If the specific gravity of the electrolyte does not rise for three consecutive readings and the charger does not shut off, then the charger is running too long.

### *Battery Voltage*

Using an accurate 5-1/2 digit digital voltmeter, monitor the battery voltage during the charging cycle. Take readings every 30 minutes. If the battery voltage does not increase 0.012 volts in two consecutive readings, then the charger is running too long.

## *Test Equipment Required for Troubleshooting*

Digital Multi Meter (DMM) with diode and capacitor test function, FLUKE 79 model shown at right and in the troubleshooting illustrations.



## *Important Notes and Instructions*

- This troubleshooting guide assumes a familiarity with the use of a digital multimeter including, voltage tests, continuity tests and diode testing. If not familiar with any part of these tests, refer testing to a qualified technician.
- Make sure that the AC electrical socket the charger is plugged into is in good working condition.
- Make sure that the AC voltage at the electrical socket is the same as the AC voltage on the charger nameplate.
- Make sure the batteries are in good condition and no less than 80% discharged as per hydrometer reading.
- The battery voltage must be above approximately 65% of the chargers rated DC voltage. If the batteries are below approximately 65% of the chargers rated DC voltage, the charger will not turn on.
- If the charger exhibits intermittent problems, it must be in the failed mode for troubleshooting.
- Battery volts = Full voltage available at the batteries at the time of the test being performed.
- This test procedure must be performed in the order it was written. If starting in the middle or skipping sections when not instructed to do so, the proper results will not occur. If the test result is good, then proceed to the next test or go to the next section if instructed to do so.

### During All Tests

#### **WARNING**

**The charger cabinet must remain electrically grounded. Disconnect both of the battery leads and unplug the charger from the AC source before disconnecting any electrical component or wire. Failure to do so may result in serious bodily injury.**

## Troubleshooting for Built-in Charger

### WARNING

1. Make sure the key-switch is in the "OFF" position, then remove the key.
2. Place the forward-reverse switch in the center "OFF" position.
3. Set the park brake.
4. Place blocks under the front wheels to prevent vehicle movement.

5. Disconnect the charger from the AC source.

Locate the charger harness connectors where the charger harness is connected to the vehicle's control harness. There will be two 10 gauge and two 14 gauge wires.

Slide the insulators off the connectors on the two 10 gauge wires and perform the following tests:

### CAUTION

**Make sure that these two wires do not come into electrical contact with any other object.**

6. Test the voltage from the red wire to the main battery negative. This voltage should be equal to the battery voltage. If the voltage is less than the battery voltage, then this wire is broken or has a bad connection. **Stop here and repair the problem.**
7. Test the voltage from the red 10 gauge wire (+) to the other 10 gauge wire (white or black depending on model). This voltage should be equal to the battery voltage. If the voltage is less than the battery voltage, then the white (or black) wire is broken or has a bad connection. **Stop here and repair the problem.**

Slide the insulators back onto the connectors on the two 10 gauge wires.

Slide the insulators off the connectors on the two 14 gauge wires.

### WARNING

**High Voltage. Do not touch the 14-gauge wires and make sure these two wires do not come into electrical contact with any other object. Failure to do so may result in serious bodily injury.**

Re-Connect the charger to the AC source.

8. Test the voltage across the two 14 gauge wires. This voltage should be the same as the voltage at the AC receptacle (rated voltage of the charger). If the voltage is less than the rated AC voltage of the charger then the 14 gauge white or black wire(s) is broken or has a bad connection between the charger connectors and the AC plug. **Stop here and repair the problem.**

- Disconnect the charger from the AC source.
- Disconnect the batteries.
- Disconnect the charger from the vehicle's harness.
- Remove the charger from the vehicle.

## WARNING

**HIGH VOLTAGE** may be stored in the capacitor. Discharge the capacitor before continuing. Connect a 2k ohm resistor across the capacitor terminals for 10 seconds. Do not touch the capacitor terminals with your hands. The resistor should be held with a pair of insulated pliers. Failure to do so may cause serious bodily injury

### Remove the charger cover and perform the following tests:

1. Inspect the internal wiring of the charger and repair as required.
2. Check the continuity of both fuse links and replace if bad.
3. Disconnect one transformer lead from the capacitor. Test the capacitor using the capacitor test function of the meter. It is a 6 microfarad capacitor. If the capacitor is bad, it must be replaced. **Stop here and repair the problem.**

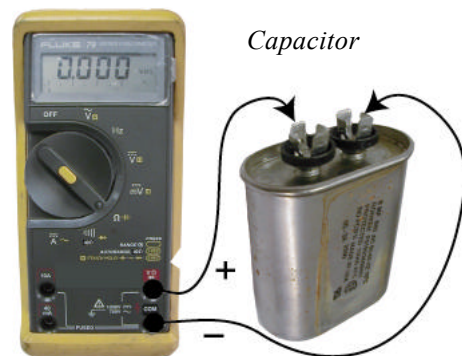
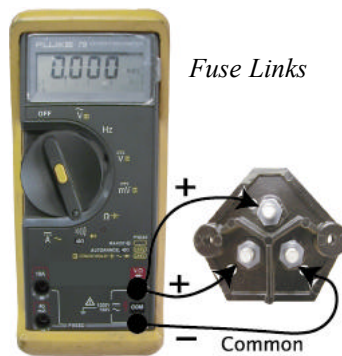

4. Reconnect the transformer lead to the capacitor and disconnect one transformer lead from one of the diodes. Test each of the diodes using the diode test function of your meter. If either one of the diodes are bad, replace the diode assembly. **Stop here and repair the problem.**

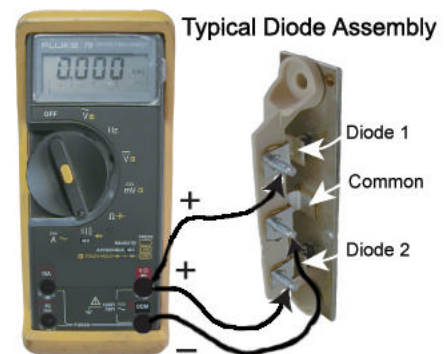

5. Reconnect the lead to the diode.
6. Reconnect the charger to the vehicle's harness and slide the wiring insulators back into place. Connect the charger to the AC source and perform the following tests:

## WARNING

**High Voltage** inside the charger. Do not touch any internal components while the charger is plugged in. Failure to do so may result in serious bodily injury.

- Test the voltage from the fuse assembly (-) to the diode block (+). This voltage should be equal to the battery voltage. If the voltage is less than the battery voltage, then the wires from the harness connectors to the charger are bad. **Stop here and repair the problem.**



- Test the voltage across the white and black wires that are connected to the timer board. This voltage should be the same as the rated AC voltage of the charger. If the voltage is less than the rated AC voltage of the charger, then the wires from the harness connectors to the charger are bad. **Stop here and repair the problem.**
- If the timer relay does not pickup (click) when the AC source is connected, then the timer control circuit or the relay is bad (refer to Timer Relay Test). **Stop here and repair the problem.**
- Test the AC voltage across the transformer primary circuit. The transformer primary consists of the two solid wires with the brown fiber insulator that are connected to the timer board. This voltage should be the same as the rated AC voltage of the charger. If the voltage is less than the rated AC voltage of the charger, then the timer relay is bad. **Stop here and repair the problem.**

- Test the AC voltage across the transformer low voltage secondary circuit. The transformer low voltage secondary circuit can be tested at the two solid wires with the brown fiber insulator that are connected to the anodes on the two diodes. The voltage here will vary depending on the state of charge in the batteries. The voltage should be between 208% and 250% of the rated DC voltage of the charger. If the voltage is not between 208% and 250% of the rated DC voltage of the charger, the transformer is bad and must be replaced. **Stop here and repair the problem.**



## Troubleshooting for Portable Charger

Disconnect the charger from the AC outlet and the batteries.

1. Test the voltage from the positive terminal on the vehicles DC receptacle to main battery negative. This voltage should be equal to the battery voltage. If the voltage is less than the battery voltage then this wire is broken or has a bad connection. **Stop here and repair the problem.**
2. Test the voltage from the positive terminal on the DC receptacle to the negative terminal on the DC receptacle. This voltage should be equal to the battery voltage. If the voltage is less than the battery voltage, then the wire on the negative terminal of the DC receptacle is broken or has a bad connection. **Stop here and repair the problem.**

Remove the charger cover and perform the following tests:

### WARNING

**HIGH VOLTAGE may be stored in the capacitor. Discharge the capacitor before continuing. Connect a 2k ohm resistor across the capacitor terminals for 10 seconds. Do not touch the capacitor terminals with your hands. The resistor should be held with a pair of insulated pliers. Failure to do so may cause serious bodily injury**

1. Inspect the internal wiring of the charger and repair as required.
2. Check the continuity of both fuse links and replace if bad.
3. Disconnect one lead from the capacitor. Test the capacitor using the capacitor test function on the meter. If the capacitor is bad, it must be replaced. **Stop here and repair the problem.**

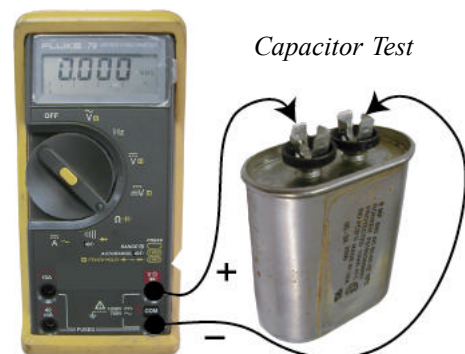
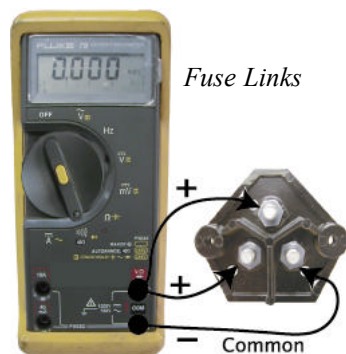

4. Reconnect the lead to the capacitor and disconnect one transformer lead from one of the diodes. Test each of the diodes using the diode test function on the meter. If either one of the diodes are bad, replace the diode assembly. **Stop here and repair the problem.**
5. Reconnect the lead to the diode.

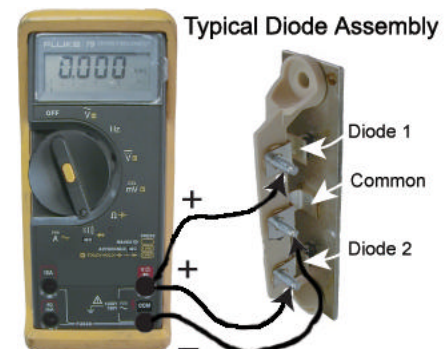



6. Connect the charger to the AC source. Insert the DC charger plug into the DC receptacle and perform the following tests:

## **WARNING**

**High Voltage inside the charger. Do not touch any internal components while the charger is plugged in. Failure to do so may result in serious bodily injury.**

- Test the voltage from the fuse assembly (-) to the diode block (+). This voltage should be equal to the battery voltage. If the voltage is less than the battery voltage, then the DC cord is bad. **Stop here and repair the problem.**
- Test the voltage across the white and black wires that are connected to the timer board. This voltage should be the same as the rated AC voltage of the charger. If the voltage is less than the rated AC voltage of the charger then the AC cord is bad. **Stop here and repair the problem.**
- If the timer relay does not pickup (click) within 5 seconds of connecting the DC charger plug, then the timer control circuit or the relay is bad (refer to Timer Relay Test). **Stop here and repair the problem.**
- Test the AC voltage across the transformer primary circuit. This voltage should be the same as the rated AC voltage of the charger. If it is less than the rated AC voltage of the charger, then the timer relay is bad. **Stop here and repair the problem.**



*Transformer Secondary Circuit*

- Test the AC voltage across the transformer secondary circuit. The voltage here will vary depending on the state of charge in the batteries. The voltage should be between 208% and 250% of the rated DC voltage of the charger. If the voltage is not between 208% and 250% of the charge's rated DC voltage, the transformer is bad and must be replaced. **Stop here and repair the problem.**

## *Testing The Timer Relay*

### Test 1:

1. Connect the batteries to the charger.
  2. Plug the charger into the AC source.
  3. Wait 5 seconds, then test the voltage at the timer relay coil terminals.  
NOTE: This voltage should be close to the battery volts.
- If the voltage is close to the battery volts, then skip to test 2.
  - If the voltage is not close to the battery volts, then the timer control circuit has failed and the timer must be replaced.

### Test 2:

1. Disconnect the batteries.
2. Unplug the charger from the AC source.
3. Discharge the capacitor (see warning on previous page).



4. Disconnect the wires from the contact terminals on the timer relay.
  5. Reconnect the batteries.
  6. Wait 5 seconds, then test the continuity across the timer relay contact terminals.
- If this is a closed circuit, then the timer start up circuit is functioning normally.
  - If there is an open circuit, then the timer relay has failed and the relay must be replaced.

## *Testing the Interlock Relay*

### Operation

The Interlock Relay disables the vehicle from running whenever the charger is connected to a working AC power source. When the charger is plugged in, the relay contacts open and break the Key Switch connection

### **⚠ WARNING**

1. **Make sure the key-switch is in the "OFF" position, then remove the key.**
2. **Place the forward-reverse switch in the center "OFF" position.**
3. **Set the park brake.**
4. **Place blocks under the front wheels to prevent vehicle movement.**
5. **Disconnect the main positive and negative cables at the batteries.**

to the speed controller. The Interlock Relay is available for built-in chargers only. Not all built-in chargers are equipped with this relay. To identify chargers that are equipped with the Interlock Relay:

Inspect the charger wire harness where it enters the charger cabinet for two Violet/Black wires. If these wires are present then the charger is equipped with the Interlock Relay.

### Testing

6. Disconnect the charger from the AC power source.
  7. Disconnect the two Violet/Black wires at the charger harness knife connectors.
  8. Set the DMM to check for continuity and connect the DMM leads to the wires going into the charger.
    - The DMM should indicate a closed circuit. If the DMM indicates an open circuit, then the relay or the wires to the relay have failed. **Stop here and repair the problem.**
  9. Connect the charger to a working AC power source.
    - The charger should turn on. If the charger does not turn on then there may be a problem with the AC power source or the AC wiring to the charger. Refer to the beginning of this section for charger troubleshooting. **DO NOT** continue until you have confirmed that the AC power source is working.
    - The DMM should indicate an open circuit. If it still indicates a closed circuit, then the relay or the wires to the relay have failed. **Stop here and repair the problem.**
- If the DMM indicates an open circuit then the interlock relay is functioning normally.

# Section 4C

## Signet® Charger Troubleshooting

### TABLE OF CONTENTS

Operating Instructions and Theory of Operation .....	2
Testing the Charging Cycle .....	3
Test Equipment Required for Troubleshooting .....	4
<b>Important Notes and Instructions</b> .....	<b>4</b>
Status LED Error Code .....	5
Troubleshooting .....	6

#### **⚠ CAUTION**

Turn the Key switch **OFF** **BEFORE** disconnecting the batteries. Disconnecting the batteries with the key switch **ON** may corrupt the controller programming resulting in a fault code 1 (refer to fault table).



**OPERATING INSTRUCTIONS AND THEORY OF OPERATION**

The model HB600W® and HB1000W® chargers are designed as semiautomatic chargers. The charger turns itself on when it is plugged into the wall outlet and turns off when the batteries are fully charged.

Both the HB600W® and HB1000W® are two stage chargers. The first stage is a constant current mode. It Maintains a constant current until the battery reaches a terminal voltage and then switches to the second stage, constant voltage. At the second stage the charger decreases the charger current while holding the batteries at the terminal voltage until the charging cycle is complete.

The charger faceplate has three status LED's that monitor the charging status. Refer to the chart below.

Charging Status	Left	Middle	Right
0-50%	<b>FLASHING</b>	OFF	OFF
50% -75%	ON	<b>FLASHING</b>	OFF
75% -100%	ON	ON	<b>FLASHING</b>
Charging Cycle complete	ON	ON	ON
Error, refer to troubleshooting	<b>FLASHING</b>	<b>FLASHING</b>	<b>FLASHING</b>

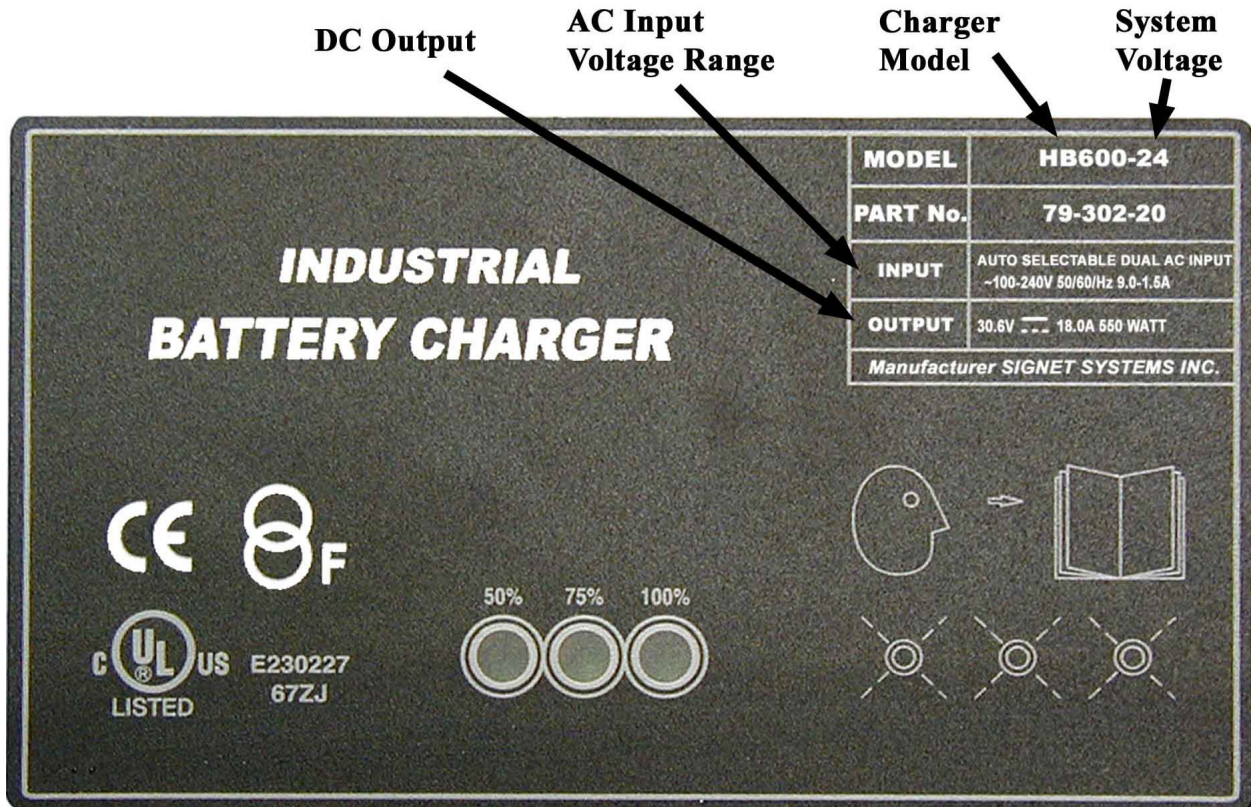

## TESTING THE CHARGING CYCLE

---

In typical installations, the charger will remain on for up to 14 hours depending on the state of charge of the battery when the charge cycle was started.

A charger could remain on for longer than 14 hours if:

- The vehicle is equipped with batteries larger than 220 Amp hour capacity.
- The charging cycle is interrupted at any time during the charging cycle.
- Defective batteries causing a fluctuating DC voltage that confuses the charger.
- One or more defective cells in the battery pack.
- A brownout (drop in AC line voltage) during the charging cycle.
- An electrically noisy charging environment.

A charger could turn off in less than 12 hours, but still show symptoms of overcharging if:

- The electrolyte in the batteries is too high (boil over).
- The electrolyte in the batteries is too low (excessive gassing or sulfur smell).

To test the charger to see if it is turning off correctly, monitor the battery voltage and charging current during the charging cycle as indicated below.

Using a digit digital voltmeter and clamp on DC ammeter, monitor the battery voltage and current during the charging cycle. The charging current should remain within 10% of the DC output current (see previous page) until the battery voltage reaches 2.55 volts per cell. When the voltage reaches 2.55 volts per cell, the charging current will drop significantly and slowly taper off (voltage will remain constant). The charger should turn off 2-4 hours after entering the second stage.



## ***TEST EQUIPMENT REQUIRED FOR TROUBLESHOOTING***

Digital Multi Meter (DMM) with diode and capacitor test function, FLUKE 79® model shown at right and in the troubleshooting illustrations.

Clamp on DC ammeter to measure up to 20-Amps.



### **Important Notes and Instructions**

- This troubleshooting guide assumes a familiarity with the use of a digital multimeter including, voltage tests, continuity tests and diode testing. If not familiar with any part of these tests, refer testing to a qualified technician.
- Make sure that the AC electrical socket the charger is plugged into is in good working condition.
- Make sure that the AC voltage at the electrical socket is the same as the AC voltage on the charger nameplate.
- Make sure the batteries are in good condition.
- If the charger exhibits intermittent problems, it must be in the failed mode for troubleshooting.
- Battery volts = Full voltage available at the batteries at the time of the test being performed.
- There are no internally serviceable components in the charger. If the charger has failed then it must be replaced.

### **⚠ CAUTION**

**This charger is rated for 115 VAC or 230 VAC operation. When switching from one input voltage to the other, Wait until all three status LED's are off. Switching voltage when any of the LED's are on will result in damage to the charger.**





## STATUS LED ERROR CODE

There are three status lights (LED's) on the charger name plate. These LED's normally indicate the current operating state of the charger. All three LED's flashing indicate an error in the charger. See the table below for an explanation if the error codes:

Error Code	Description	Action Required
1	Reverse polarity or open circuit to the batteries	Check wiring for corrosion, loose connections, broken wires and proper connection to the batteries
2	AC line voltage too high or too low	Check the input voltage. It must be within 96-132VAC or 196-266VAC
3	Charger overheated	Wait for charger to cool, the charger will automatically restart. Inspect for dirt or debris on the charger cooling fins and clean as required.
4	Input or Output over current	Charger will automatically correct for this condition and restart

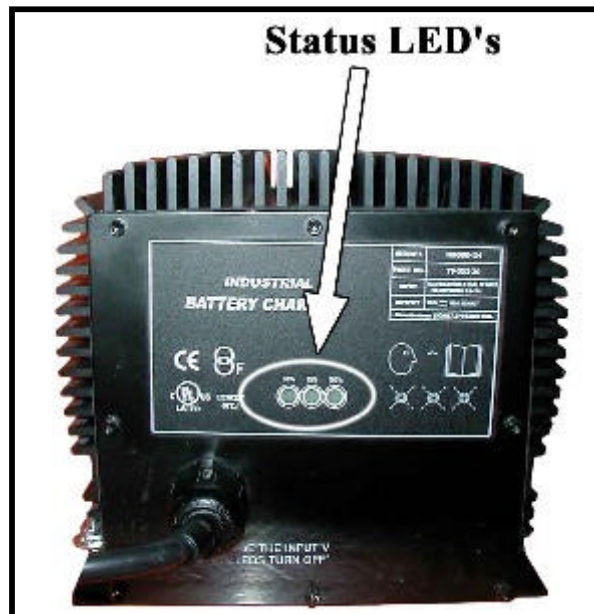

## TROUBLESHOOTING

To test charger operation:

Connect a DC volt meter to the main battery positive and negative terminals.

Attach a clamp on DC Ammeter to one of the charger DC output wires.

Plug the charger into an AC outlet.

After 5 or 6 seconds, the ammeter should display the DC Amp rating of the charger (plus or minus 10%) indicating that the charger is on (constant current mode).

The ammeter should continue to display the DC Amp rating of the charger until the battery voltage equals 2.55 VPC. When the battery voltage equals 2.55 VPC the charger will switch to the constant voltage mode. At this point the charging current will be reduced and will taper off until the batteries are fully charged.

Perform the following if the charger does not turn on:

### **WARNING**

1. **Make sure the key-switch is in the "OFF" position, then remove the key.**
2. **Place the forward-reverse switch in the center "OFF" position.**
3. **Set the park brake.**
4. **Place blocks under the front wheels to prevent vehicle movement.**

5. Disconnect the charger from the AC source.
6. Remove the charger end cap where the DC wires enter.
7. Test the voltage across the Battery Positive (red) and Battery Negative (black) wires at the lower left of the charger circuit board. This voltage should be equal to the battery voltage. If the voltage is less than the battery voltage, then the wires to the batteries have been damaged. **Stop here and repair the problem.**
8. Reinstall the charger end cap where the DC wires enter.
9. Remove the charger end cap where the AC wires enter.
10. Test the continuity of all three AC wires from the circuit board to the AC plug. If you find an open circuit in any one of the three wires then the AC cord or plug has been damaged. **Stop here and repair the problem.**
11. Install the charger end cap where the AC wires enter.

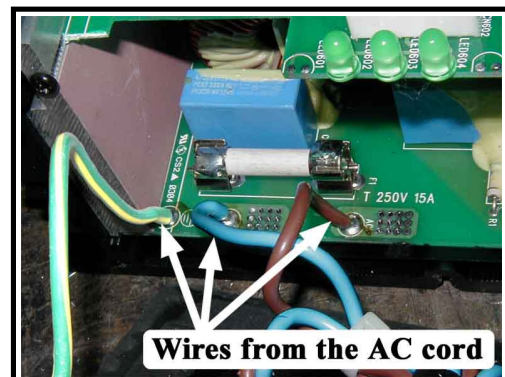
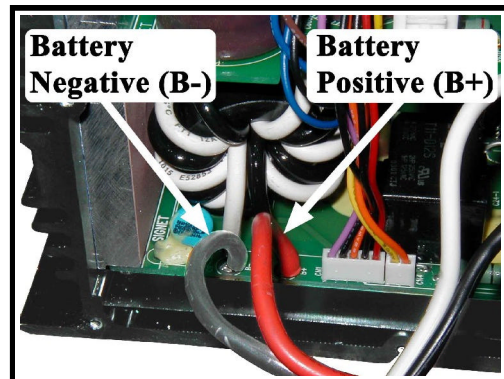

If both the AC and DC tests are good then the charger has failed. There are no internally serviceable components in the charger. If the charger has failed then it must be replaced.



# Illustrated Parts List

---



## ILLUSTRATED PARTS

# IDENTIFYING YOUR VEHICLE

If you are unsure of the vehicle that you are working on. Refer to the figures at the right.

Starting from the top of the page they are as follows:

SS5-34

SS5-36

MX-600

SS5-46

Whenever necessary the model of the vehicle is identified with the parts that are specific to that model. If there is no model identification either in the Diagram Heading or within the table, then the part can be utilized in all models.



**SS5-34**

**SS5-36**

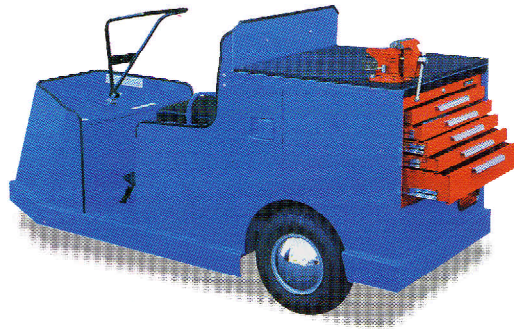

**MX-600**

**SS5-46**



ILLUSTRATED PARTS

# BRAKE PEDAL LINKAGE AND ACCELERATOR PEDAL (SS5-34)

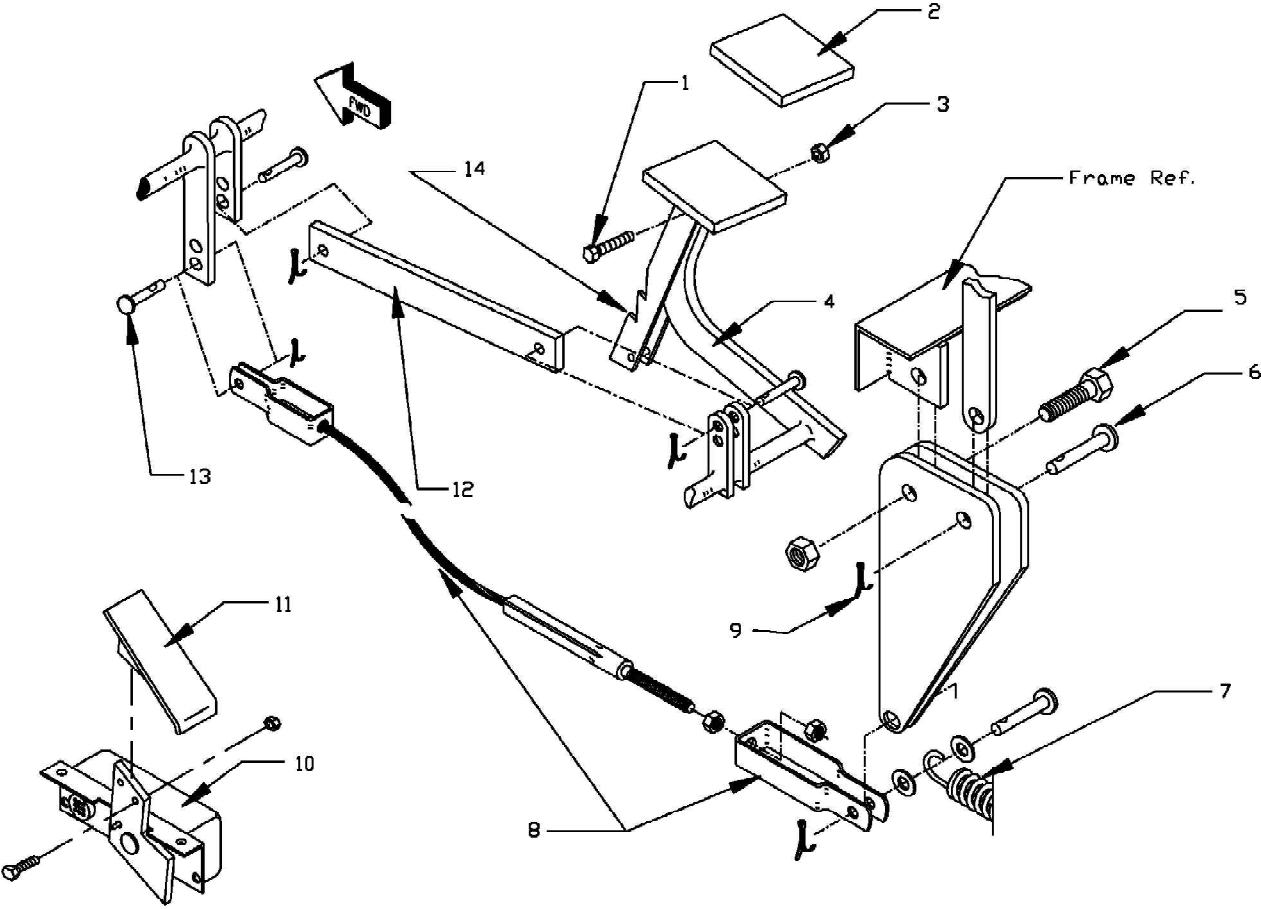



### Brake Linkage/ Accelerator Pedal

ITEM#	PART#	DESCRIPTION	QTY
1	88-140-14	1/2" NC X 1-1/2" Hex Head Cap Screw	1
2	98-200-00	Brake Pedal Pad, Rubber	1
3	88-089-81	1/2" NC Locknut	2
4	01-534-67	Brake Arm Weldment	1
5	88-140-14	1/2" NC X 1-1/2" Hex Head Cap Screw	1
6	96-772-00	3/8" X 1" Clevis Pin	3
7	85-060-00	Return Spring	1
8	96-813-00	28-1/4" to 31-1/4" Brake Cable Assy	1
9	88-517-11	3/32" X 1" Cotter Pin	7
10	62-033-00	Accelerator Module	1
11	98-254-10	Accelerator Pedal	1
12	50-432-00	Brake Pedal Connecting Link	1
13	96-771-00	3/8" X 3/4" Clevis Pin	1
14	51-508-00	Brake Pedal, w/P.Brake Locks	1

ILLUSTRATED PARTS

# BRAKE PEDAL LINKAGE (SS5-36, SS5-46 AND MX-600)

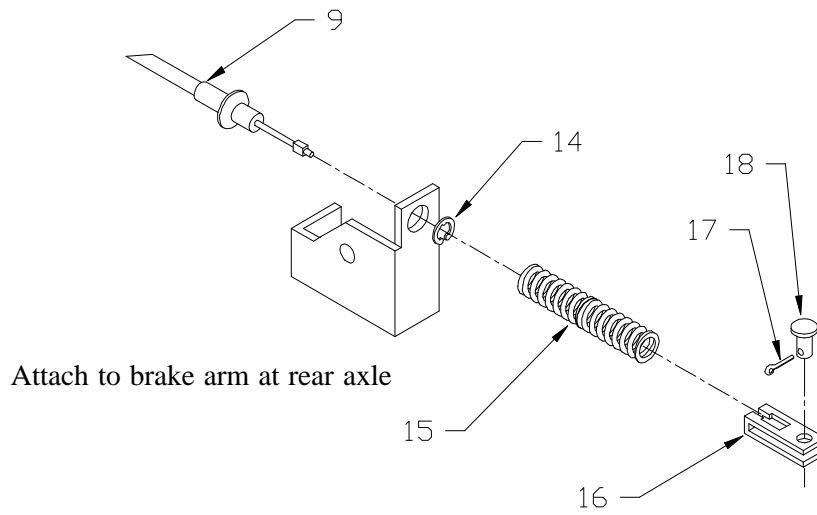
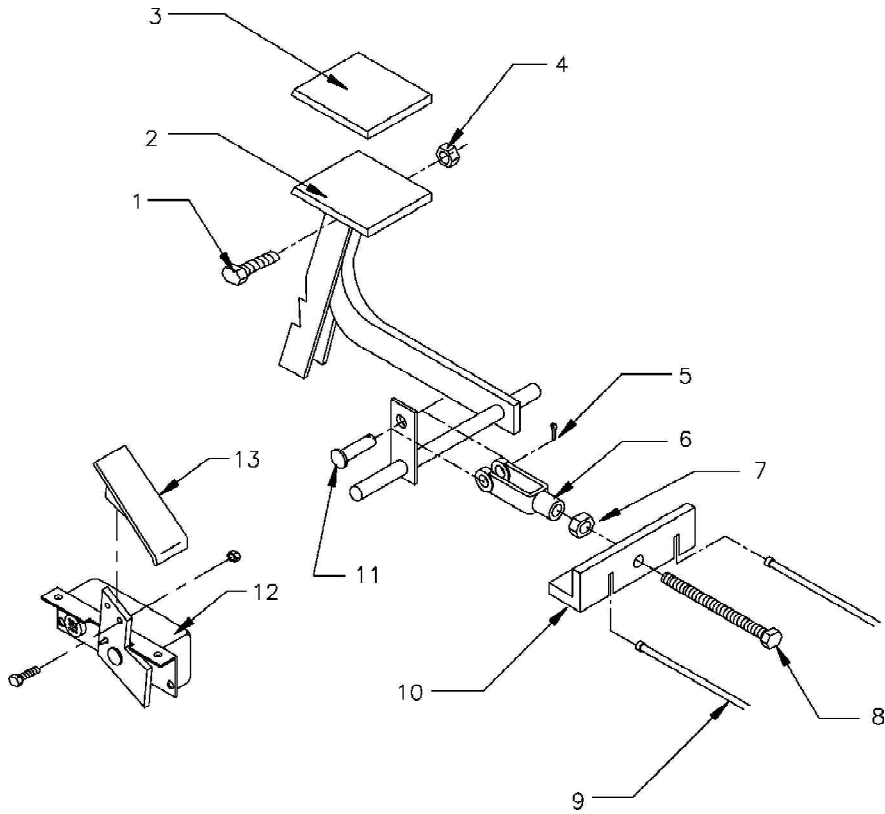



### Brake Linkage (SS5-36, sS5-46 and MX-600)

ITEM#	PART#	DESCRIPTION	QTY
1	88-140-13	1/2" X 1/4" NC Bolt	1
2	02-536-09	Pedal Lock	1
3	98-200-00	Pedal Pad	1
4	88-149-81	1/2" NC Locknut	1
5	88-527-11	1/8" X 1" Cotter Pin	1
6	96-762-00	Clevis	1
7	88-119-81	3/8" NF Jam nut	1
8	88-111-20	3/8" X 3" NF Bolt	1
9	96-826-12	Park Brake Cable Assy	1
10	02-536-06	Brake Equalizer	1
11	96-772-00	3/8" X 1" Clevis Pin	1
12	62-033-00	Accelerator Module	1
13	98-254-10	Accelerator Pedal	1
14	88-847-08	E-clip	2
15	85-125-00	Spring	2
16	96-754-00	Clevis	2
17	88-517-11	Cotter pin	2
18	96-773-00	Clevis pin	2







### Front Axle, Wheel and Suspension (SS5-34, SS5-36, and MX-600)

ITEM#	PART#	DESCRIPTION	QTY
1	88-229-81	3/4" NC Locknut	2
2	88-228-61	3/4" NC Washer	2
3	16-206-00	Spacer	2
4	15-010-00	Front Axle(Threaded each end)	1
	15-010-10	Front Axle(Single Ended)	1
5	45-308-00	Oil Seal	2
6	80-015-00	Tapered Roller Bearing	2
7	80-105-00	Bearing Race	2
8	See Tire and Wheel		
9	See Tire and Wheel		
10	See Tire and Wheel		
11	85-140-10	Spring	1





### Front Axle, Wheel and Suspension (SS5-46)

ITEM#	PART#	DESCRIPTION	QTY
1	92-104-00	Bearing cap	2
2	88-527-14	Cotter pin	2
3	88-239-85	Castle nut	2
4	88-228-61	3/4 SAE Flat washer	2
5	80-017-00	Bearing	1
6	80-103-00	Race	1
7	12-124-15	Hub	2
8	80-103-00	Race	1
9	80-017-00	Bearing	1
10	45-338-00	Seal	2
11	00-546-06	Left steering yoke	1
	00-546-07	Right steering yoke	1
12	88-109-81	3/8NC Lock nut	4
13	97-202-50	3/8NF nut, left thread	2
	88-199-80	3/8NF Hex nut	2
14	86-519-11	Rod end, left thread	2
	86-519-10	Rod end, right thread	2
15	88-108-15	3/8 x 1-3/4 Hex bolt	4
16	88-106-61	3/8 SAE Flat washer	4
17	16-506-00	Upper spacer	4
18	16-506-00	Lower spacer	4
19	88-108-61	3/8 SAE Flat washer	4
20	01-546-16	Tie rod	2
21	32-200-00	Bushing	2
22	87-073-00	Grease fitting	2
23	21-020-15	King pin	2
24	32-240-55	King pin bushings (inside axle)	4
	97-180-55	Thrust washer	4
25	88-189-81	5/8NC Lock nut	2
26	00-546-02	Steering arm	1
27	87-071-00	Grease fitting	1

# TILLER STEERING

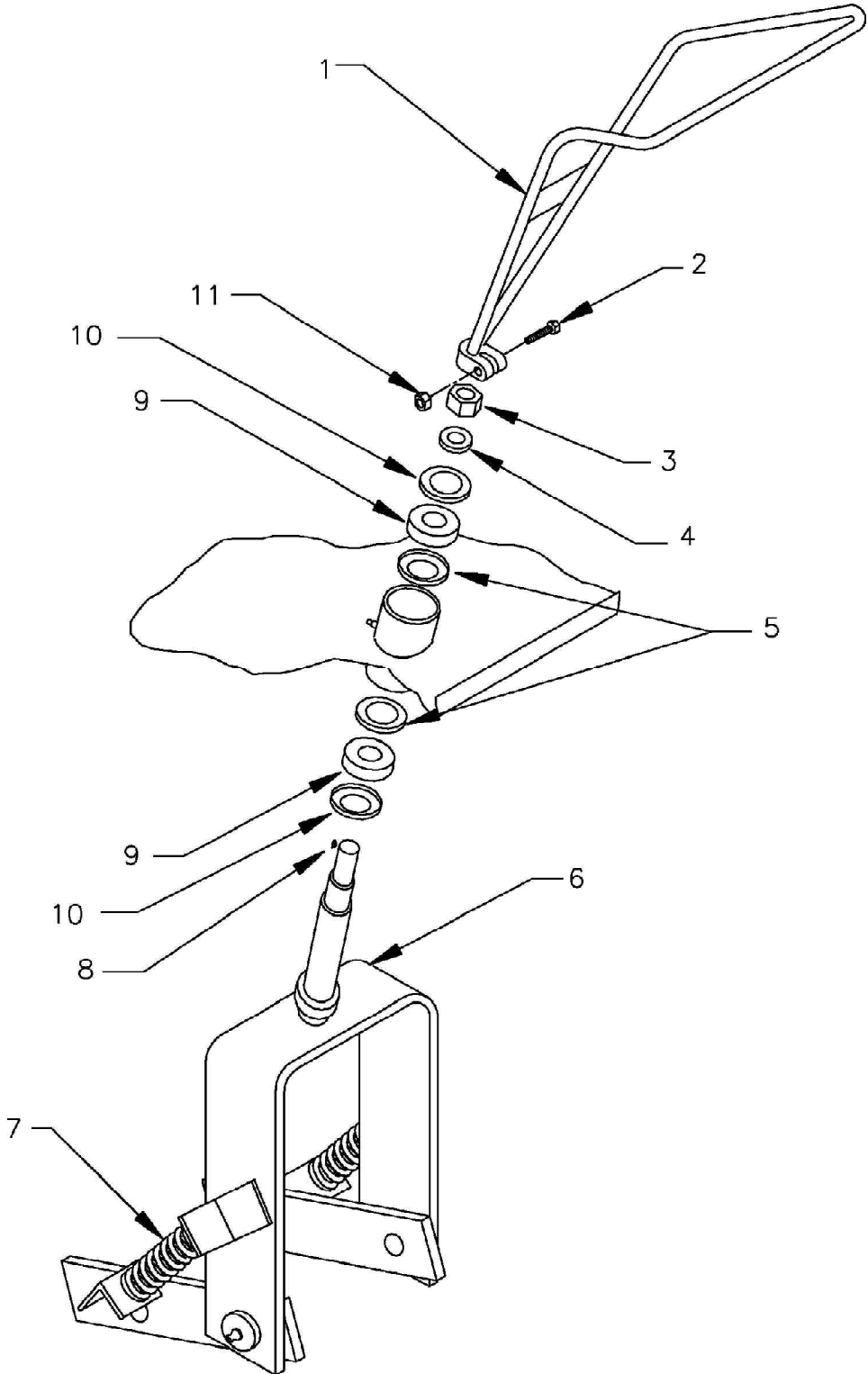

**Tiller Steering**

ITEM#	PART#	DESCRIPTION	QTY
1	19-101-20	Steering Tiller	1
2	88-140-14	1/2" X 1-1/2" NC Bolt	1
3	97-230-00	1-1/4" NF X 9/16" Locknut	1
4	16-409-00	Spacer	1
5	80-102-00	Bearing Race	2
6	14-079-20	Front Fork with Springs	1
7	85-140-10	Spring	2
8	97-100-00	Woodruff Key	1
9	80-011-00	1-1/4" Tapered Roller Bearing	2
10	45-307-00	Oil Seal, 1-1/2"ID	2
11	88-149-81	1/2" Locknut	1
Not Shown	72-005-00	4" Head Light	1

ILLUSTRATED PARTS

# GEARED STEERING (SS5-34)

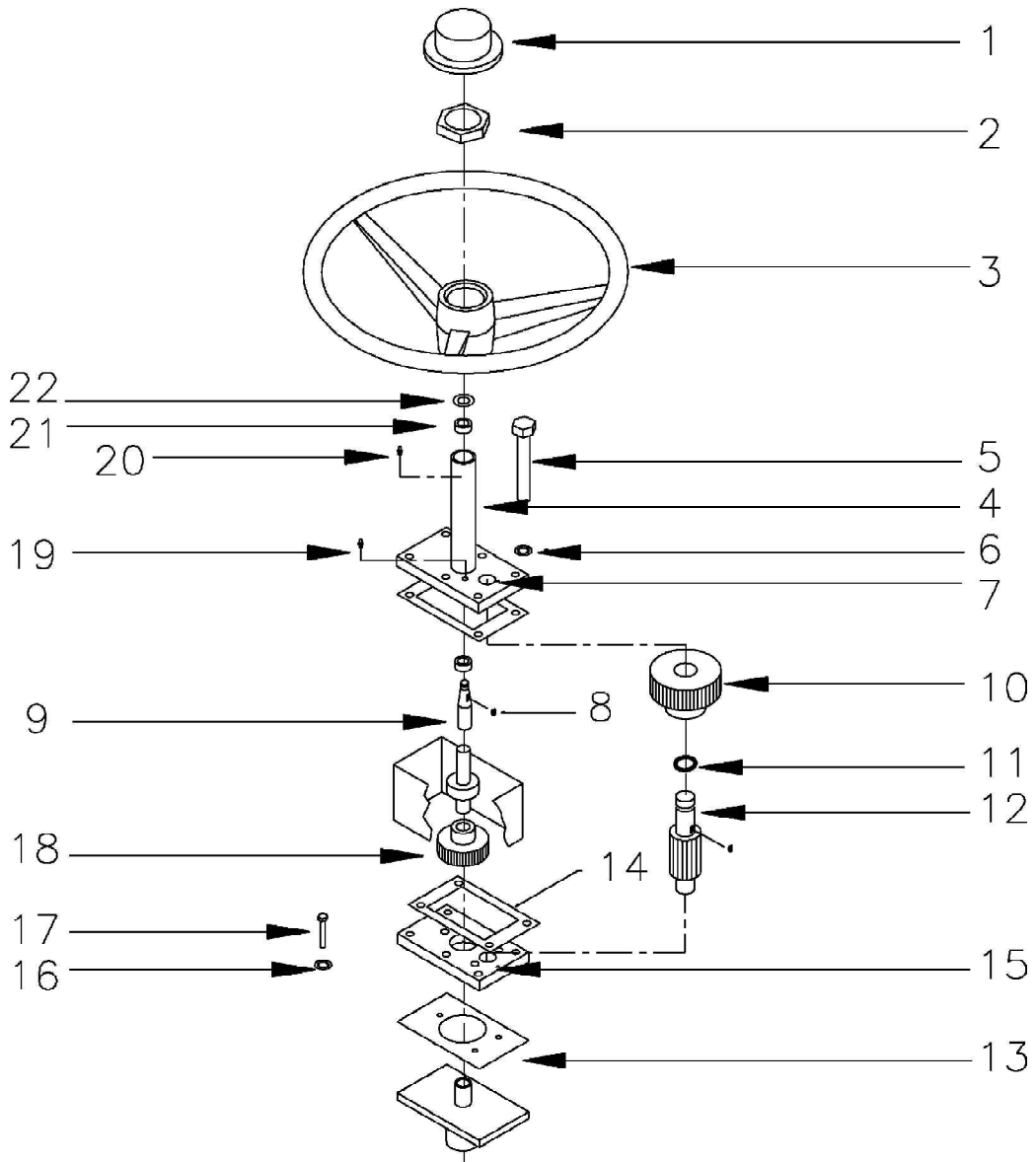



### Geared Steering (SS5-34)

ITEM#	PART#	DESCRIPTION	QTY
1	95-915-20	Cap, Black Plastic	1
2	88-199-82	5/8" Jam Nut	1
3	19-007-20	Steering Wheel	1
4	18-309-00	Gear Box Only,(With Bolts, Bushings, and Zerk Fittings.)	1
5	88-068-25	1/4" X 4-1/2"NC HEX Hd Cap Screw	6
6	88-068-62	1/4" Lockwasher	6
7	32-203-00	3/4" ID X 7/8" OD X 1/2" Long Bronze Bushing	1
8	97-100-00	3/16" Woodruff Key	1
9	20-031-00	Steering Shaft with Gear	1
10	31-253-00	36-Tooth, Spur Gear, .750 bore	1
11	80-706-00	3/4"OD O-Ring	1
12	31-255-00	7-Tooth Stem Pinion	1
13	45-003-00	4" X 4-1/2"OD Gasket	1
14	45-004-00	4" X 6" OD Gasket	2
15	32-207-00	3/8"ID X 5/8"OD X 1/2" Long Bronze Bushing	1
16	88-088-62	5/16" Lockwasher	3
17	88-088-11	5/16" X 1" HEX Hd Cap Screw	3
18	31-254-00	36-Tooth Spur Gear, .875 bore	1
19	87-074-00	1/4"-28NF Zerk Fitting	1
20	87-071-00	3/16" Zerk Fitting	1
21	80-400-10	3/4"ID Ball Bearing	2
22	16-405-00	3/4"ID X 1-1/4"OD Spacer	1
Not Shown	72-005-00	4" Headlight	1
Not Shown	72-505-05	Headlight Mount	1

ILLUSTRATED PARTS

GEARED STEERING (SS5-36, SS5-46 AND MX-600)

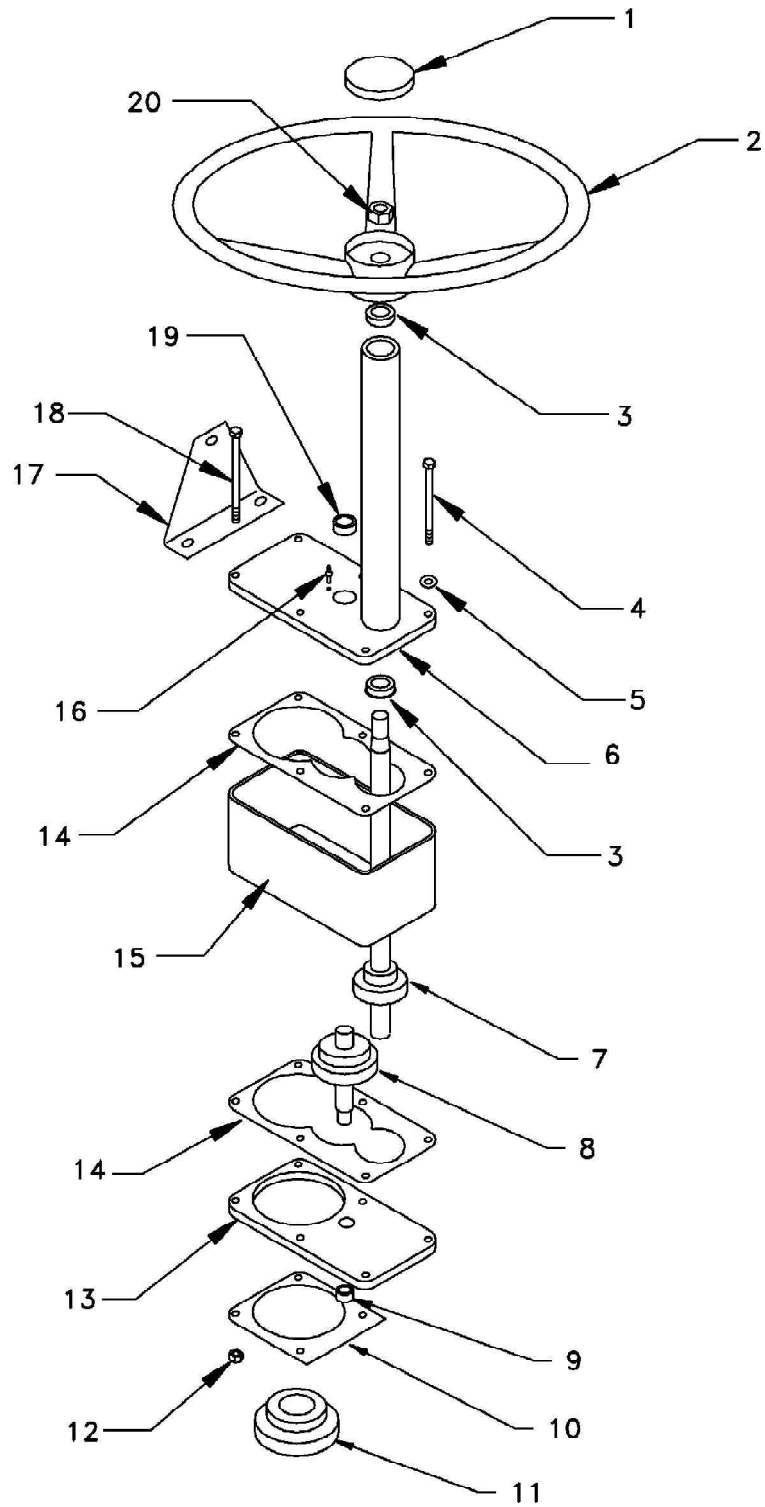





Geared Steering (SS5-36, SS5-46 and MX-600)

ITEM#	PART#	DESCRIPTION	QTY
1	19-011-25	Cover	1
2	19-011-20	Steering Wheel	1
3	80-400-10	3/4"ID Bearing	2
4	88-060-22	1/4" X 3-1/2" NC Hex Bolt	2
5	88-068-82	1/4" Lockwasher	6
6	18-309-13	Plate and Sleeve, Weldment	1
7	20-031-20	Steering Shaft and Gear	1
8	31-255-10	Stem and Gear, Weldment	1
9	32-207-00	3/8" ID X 5/8" OD Bronze Bushing	1
10	45-003-10	Mounting Plate Gasket	1
11	31-254-00	36 Tooth, Spear Gear	1
12	88-069-81	1/4" Locknut	4
13	18-039-11	Bottom Plate	1
14	45-004-10	Gear Box Gasket	1
15	18-309-12	Gear Box Case	1
16	87-071-00	3/16" Zerk Fitting	1
17	71-505-05	Head Light mounting Bracket	1
18	88-060-25	1/4" X 4-1/2"NC HEX Bolt	4
19	32-203-00	3/4"ID X 7/8"OD Bronze Bushing	1
20	88-199-82	5/8" NF Jam Nut	1
Not Shown	72-005-00	Head Light	1

ILLUSTRATED PARTS

INSTRUMENT PANEL (SS5-34,SS5-36 AND SS5-46)

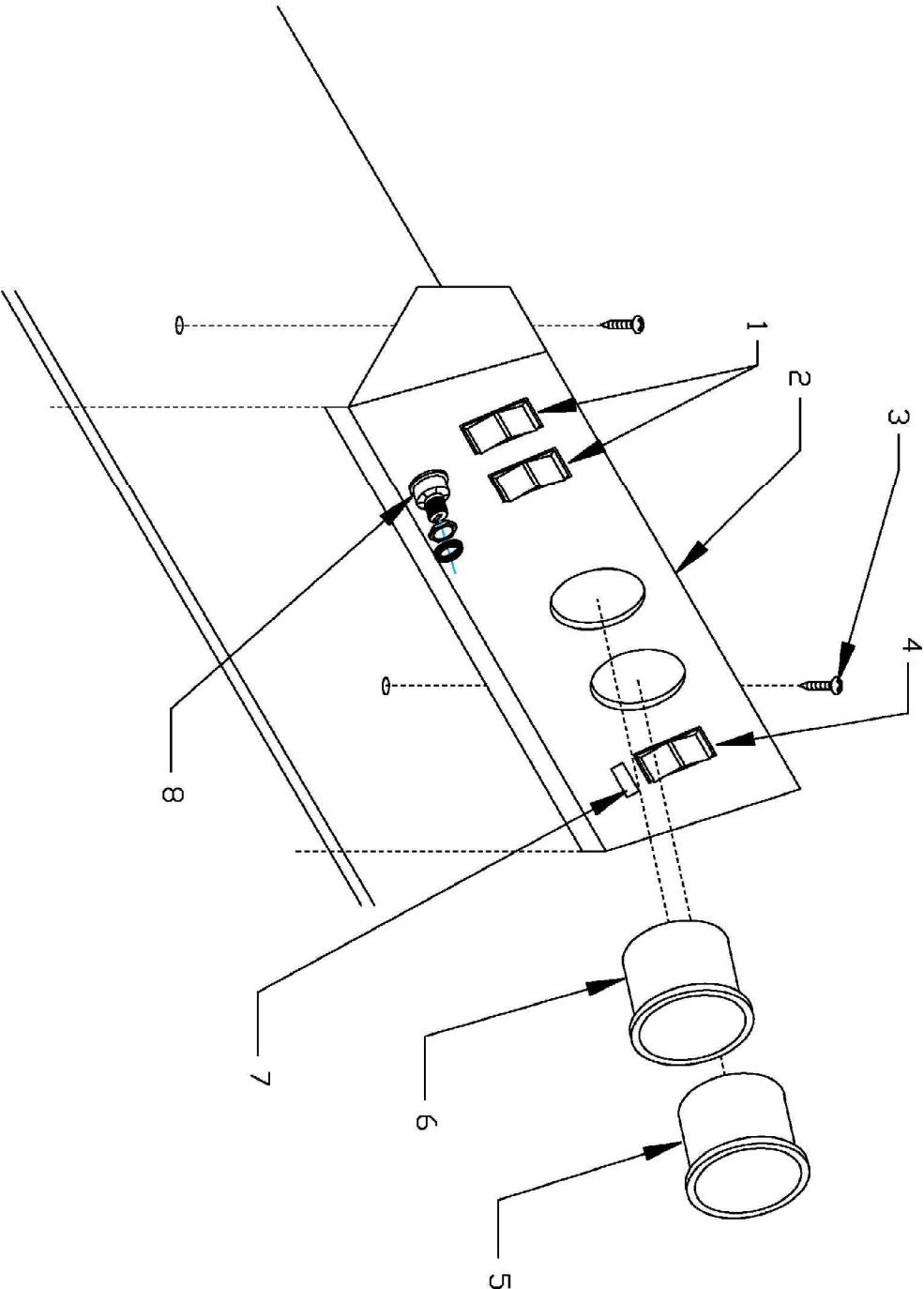



### Instrument Panel (SS5-34, SS5-36 and SS5-46)

ITEM#	PART#	DESCRIPTION	QTY
1	71-039-10	Rocker Switch	1 or 2
2	02-536-10	Instrument Panel Console	1
3	88-065-09	1/4" X 3/4" NC Phillips Hd Screw	2
4	71-039-00	Forward/Reverse Switch	1
5	74-009-10	24-volt, Battery Status Indicator	1
6	74-000-00	Hour Meter (Optional)	1
7	72-028-20	Power On Light	1
8	71-120-00	Key Switch	1
Not Shown	71-039-20	Plug	1
Not Shown	71-102-10	Seat interlock switch	1
Not Shown	02-610-18	Seat switch mount	1

ILLUSTRATED PARTS

CONTROLS AND INSTRUMENTS (MX-600)

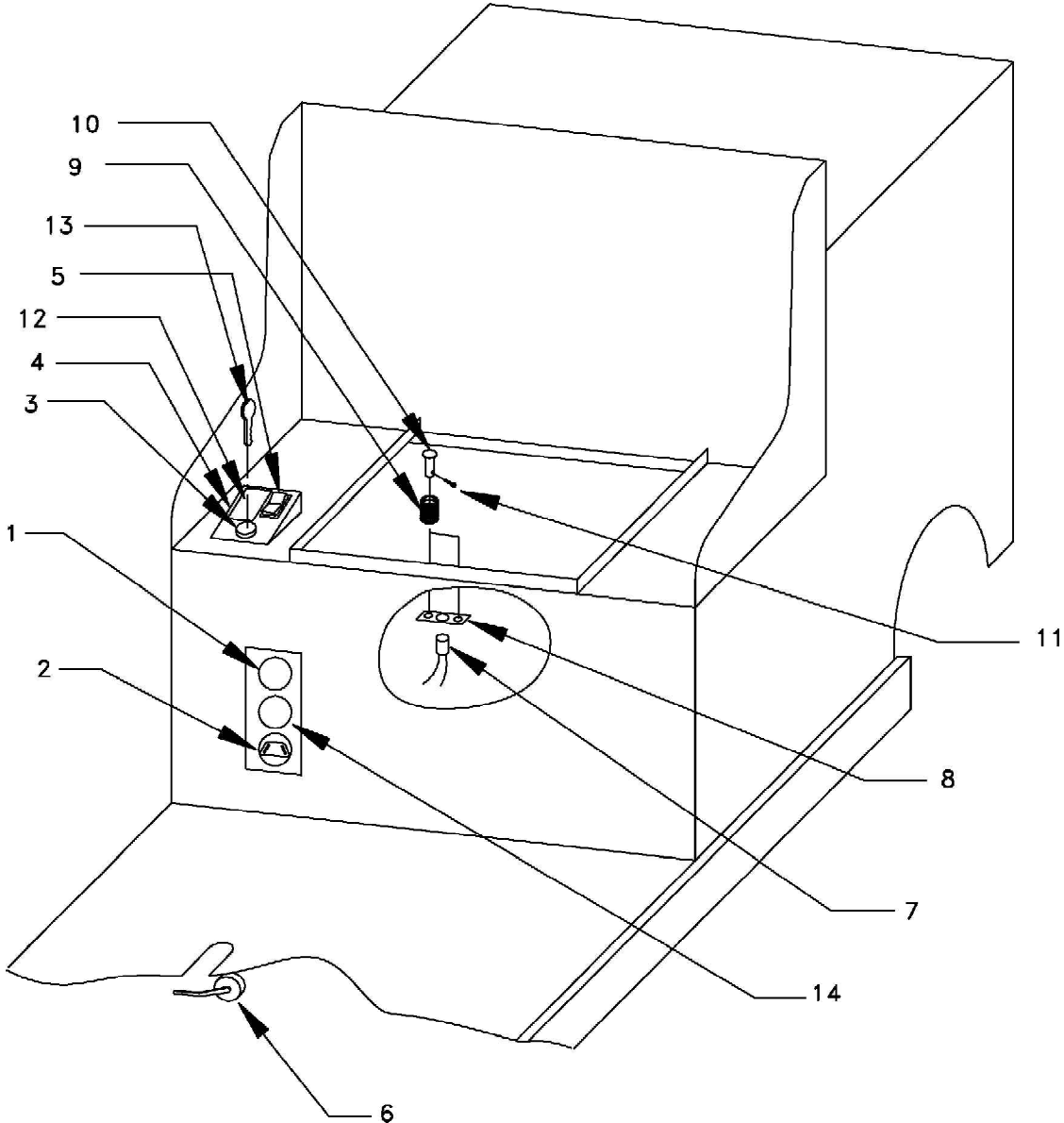



### Instrument Panel (MX-600)

ITEM#	PART#	DESCRIPTION	QTY
1	74-009-10	24V Battery Status Indicator	1
2	76-013-00	Charging Receptacle	1
3	71-120-00	Key Switch W/Keys	1
4	00-300-04	Instrument Panel	1
5	71-039-00	3-Position Rocker Switch	1
6	71-111-00	Brake Light Switch	1
7	71-102-10	Seat Switch	1
8	02-610-18	Seat Switch Mount	1
9	85-030-00	Compression Spring for Seat Switch	2
10	96-773-00	Anchor Pin for Seat Switch	2
11	88-527-11	1/8" Cotter Pin	2
12	94-312-00	Forward/Reverse Label	1
13	71-120-80	Keys	1
14	74-000-00	Hour Meter (Optional)	1

ILLUSTRATED PARTS

MOTOR SS5-34

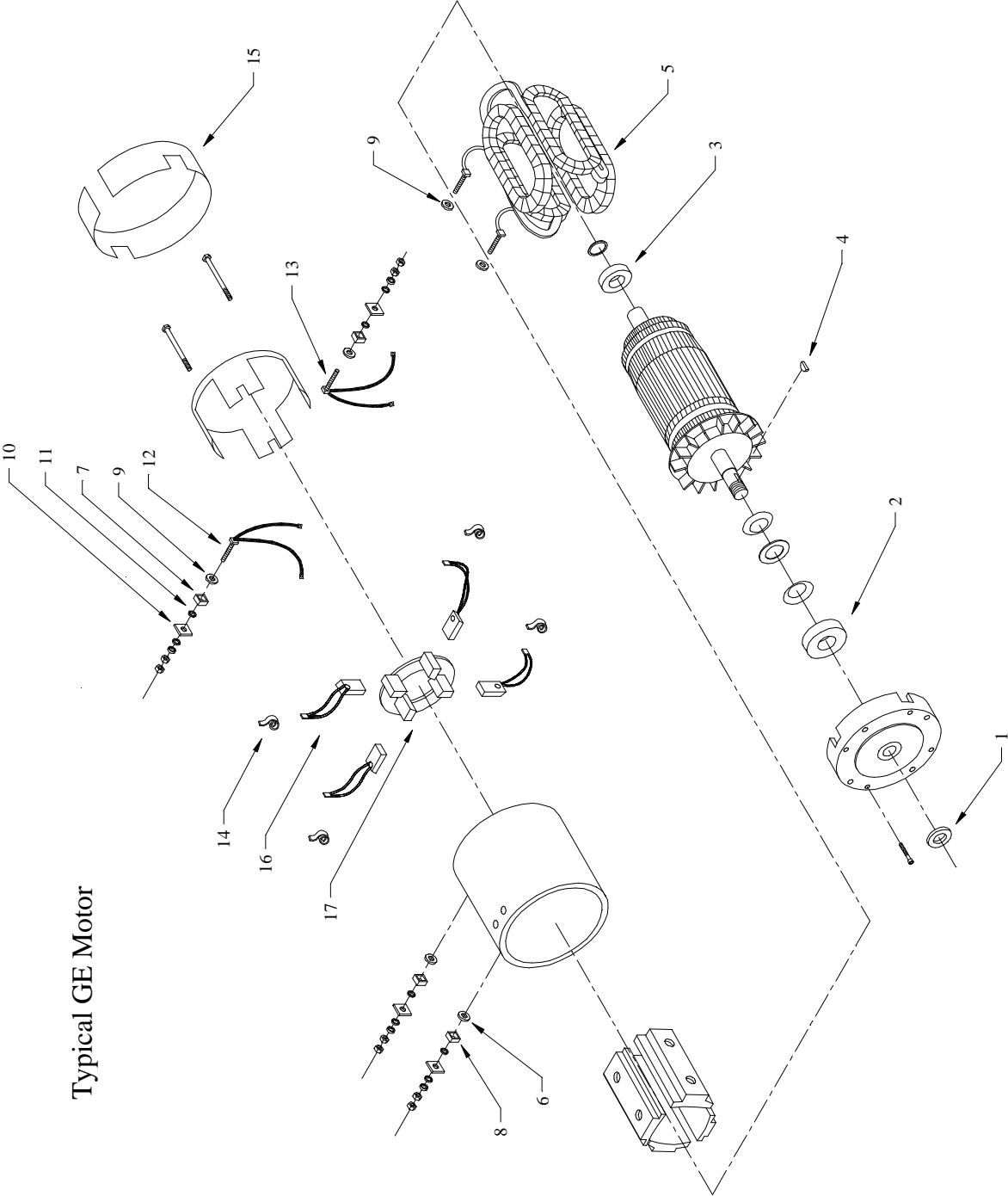

Typical GE Motor

<b>Motors, Series Wound Field</b>												
ITEM #	DESCRIPTION	Motor Spec # Motor Part #										
		5BC58JBS6110C 70-049-00	5BC58JBS6129B 70-049-05	5BC49JB399C 70-054-00	XP1706A 70-054-05	5BT1326B262A 70-055-00	5BC49JB249A 70-057-10	9475-31 70-057-20	5BC49JB3043B 70-061-00	5BT1344B185 70-072-00	L94-4006 70-074-00	
1	Oil seal	<b>45-506-00</b>	-	<b>45-508-00</b>	N/A	N/A	N/A	N/A	N/A	N/A	N/A	N/A
2	Front bearing	<b>80-504-00</b>	-	<b>80-504-00</b>	N/A	N/A	N/A	N/A	N/A	N/A	N/A	N/A
3	Rear bearing	<b>80-209-00</b>	<b>80-209-00</b>	<b>80-200-00</b>	N/A	N/A	N/A	N/A	N/A	N/A	N/A	N/A
4	Woodruff key	<b>97-100-00</b>	-	<b>97-100-00</b>	N/A	N/A	N/A	N/A	N/A	N/A	N/A	N/A
5	Field winding	<b>70-201-15</b>	<b>70-201-15</b>	<b>70-203-10</b>	N/A	N/A	N/A	N/A	N/A	N/A	N/A	N/A
6	Insulator	<b>70-210-51</b>	<b>70-210-51</b>	-	N/A	N/A	N/A	N/A	N/A	N/A	N/A	N/A
7	Bushing	-	<b>70-049-06</b>	<b>98-622-00</b>	N/A	N/A	N/A	N/A	N/A	N/A	N/A	N/A
8	Bushing	-	-	<b>98-623-00</b>	N/A	N/A	N/A	N/A	N/A	N/A	N/A	N/A
9	Insulator	-	<b>70-210-51</b>	<b>97-178-00</b>	N/A	N/A	N/A	N/A	N/A	N/A	N/A	N/A
10	Insulator	<b>70-210-50</b>	-	<b>97-179-00</b>	N/A	N/A	N/A	N/A	N/A	N/A	N/A	N/A
11	Insulator	-	-	-	N/A	N/A	N/A	N/A	N/A	N/A	N/A	N/A
-	Insulator/Bushing kit	<b>70-210-62</b>	-	<b>70-210-62</b>	N/A	N/A	N/A	N/A	N/A	N/A	N/A	N/A
12	Crossover	-	-	<b>70-195-10</b>	N/A	N/A	N/A	N/A	N/A	N/A	N/A	N/A
13	Crossover	-	-	<b>70-195-10</b>	N/A	N/A	N/A	N/A	N/A	N/A	N/A	N/A
14	Brush spring	<b>85-412-00</b>	<b>85-412-00</b>	<b>80-412-00</b>	N/A	N/A	N/A	N/A	N/A	N/A	N/A	N/A
15	Brush cover	-	-	<b>30-802-00</b>	N/A	N/A	N/A	N/A	N/A	N/A	N/A	N/A
16	Brush	<b>70-104-00</b>	<b>70-104-15</b>	<b>70-105-00</b>	N/A	N/A	N/A	N/A	N/A	N/A	N/A	N/A
17	Brush holder	<b>70-172-00</b>	<b>70-172-15</b>	<b>70-104-10</b>	N/A	N/A	N/A	N/A	N/A	N/A	N/A	N/A
18	Bearing Retainer	-	<b>32-508-15</b>	-	N/A	N/A	N/A	N/A	N/A	N/A	N/A	N/A
19	5/16NC Jam nut	N/A	<b>88-089-91</b>	N/A	N/A	N/A	N/A	N/A	N/A	N/A	N/A	N/A
20	5/16 SAE Flat washer	N/A	<b>88-088-61</b>	N/A	N/A	N/A	N/A	N/A	N/A	N/A	N/A	N/A

ILLUSTRATED PARTS

MOTOR SS5-36, SS5-46 & MX-600

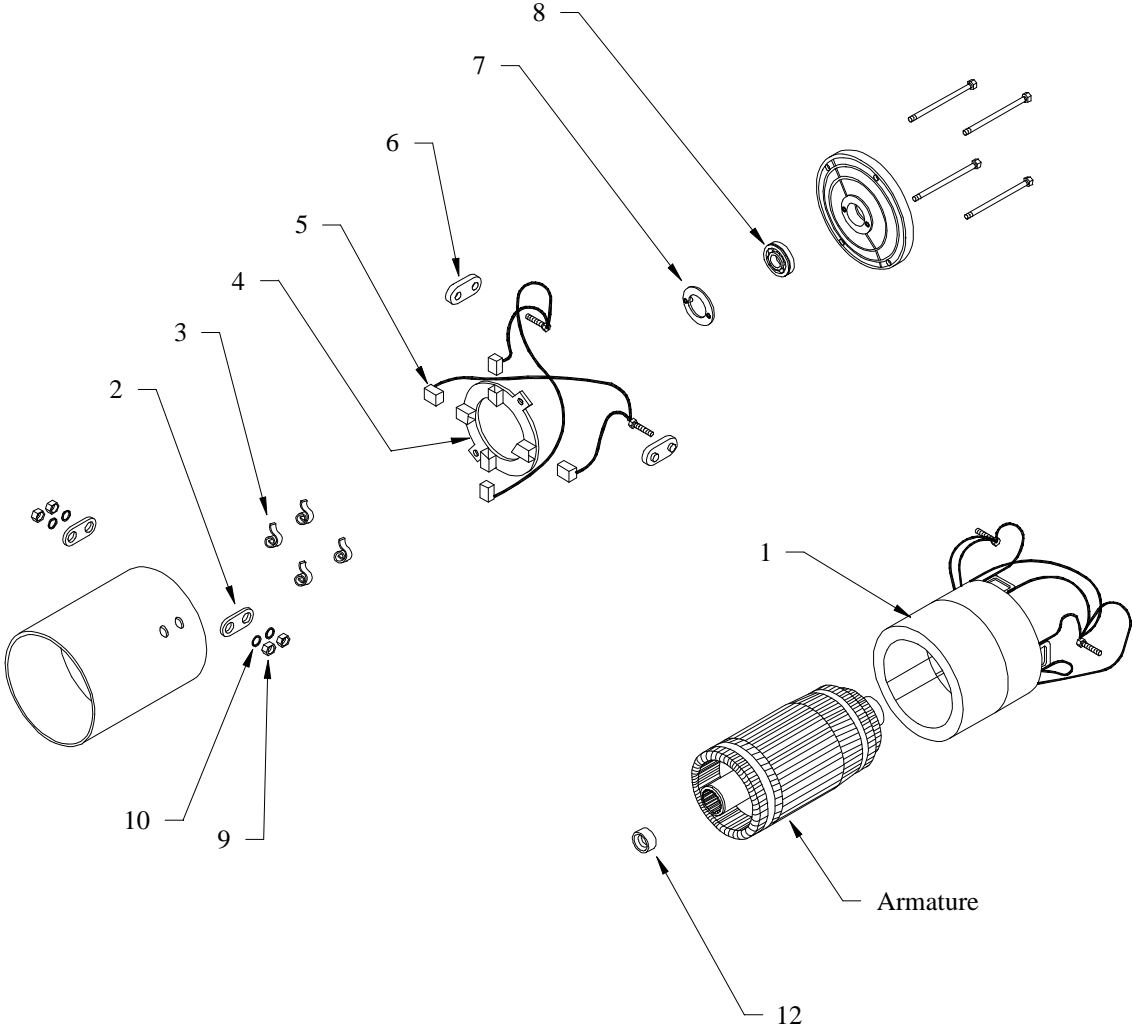





Motor GE spec# 5BC58JBS6129A			
ITEM #	PART #	DESCRIPTION	QTY
	70-049-05	Complete motor assembly (does not include #11)	
1	70-201-15	Field coils (mounted in motor housing)	1
2	70-210-51	Insulator	2
3	85-412-00	Brush spring	4
4	70-172-15	Brush holder (includes #3)	1
5	70-104-15	Motor brush (2)	2
6	70-210-51	Insulator	2
7	32-508-15	Bearing retainer	1
8	80-209-00	Bearing	1
9	88-089-91	5/16NC Jam nut	4
10	88-088-61	5/16 SAE Flat washer	4
11	-	-	-
12	70-049-06	Bushing spacer	1

ILLUSTRATED PARTS

REAR AXLE (SS5-34)

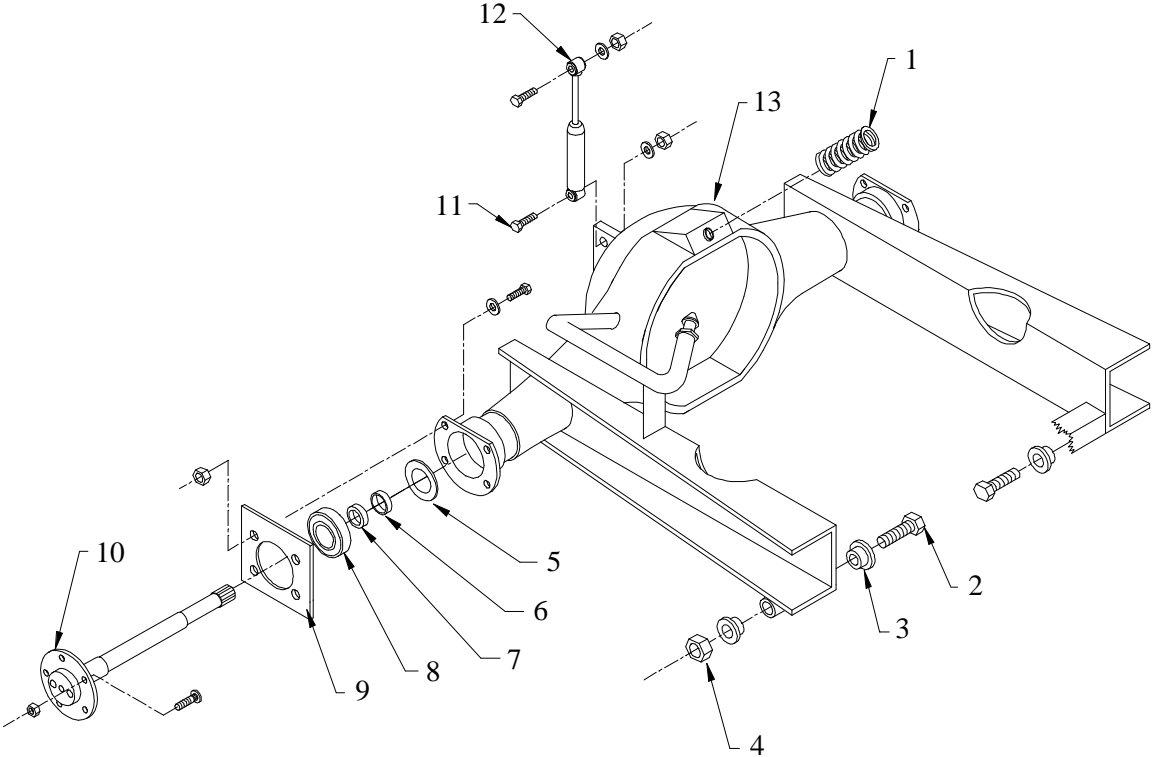

**SS5-34 Rear Axle**

ITEM#	PART#	DESCRIPTION	QTY
1	85-140-00	2-7/16" X 6-1/4" Spring	1
2	96-240-00	1/2" X 4" Bolt	2
3	98-601-00	Rubber Grommet, 1/2" ID	4
4	88-149-81	1/2"NC Locknut	2
5	45-045-00	Rear Axle Bearing Gasket	2
6	45-301-00	Oil Seal	2
7	32-515-00	Bearing Retainer Ring	2
8	80-503-00	Bearing for Rear Axle	2
9	32-514-00	Rear Axle Retaining Plate	2
10	41-166-11	Right Side Axle w/ Bearing and Retainer Plate	1
	41-165-11	Left Side Axle w/ Bearing and Retainer Plate	1
11	88-180-18	5/8"NC X 2-1/2" Hex Head Bolt	2
12	86-602-00	Shock Absorber	1
13	41-296-00	Housing	1

ILLUSTRATED PARTS

REAR AXLE (SS5-36, SS5-46 AND MX-600)

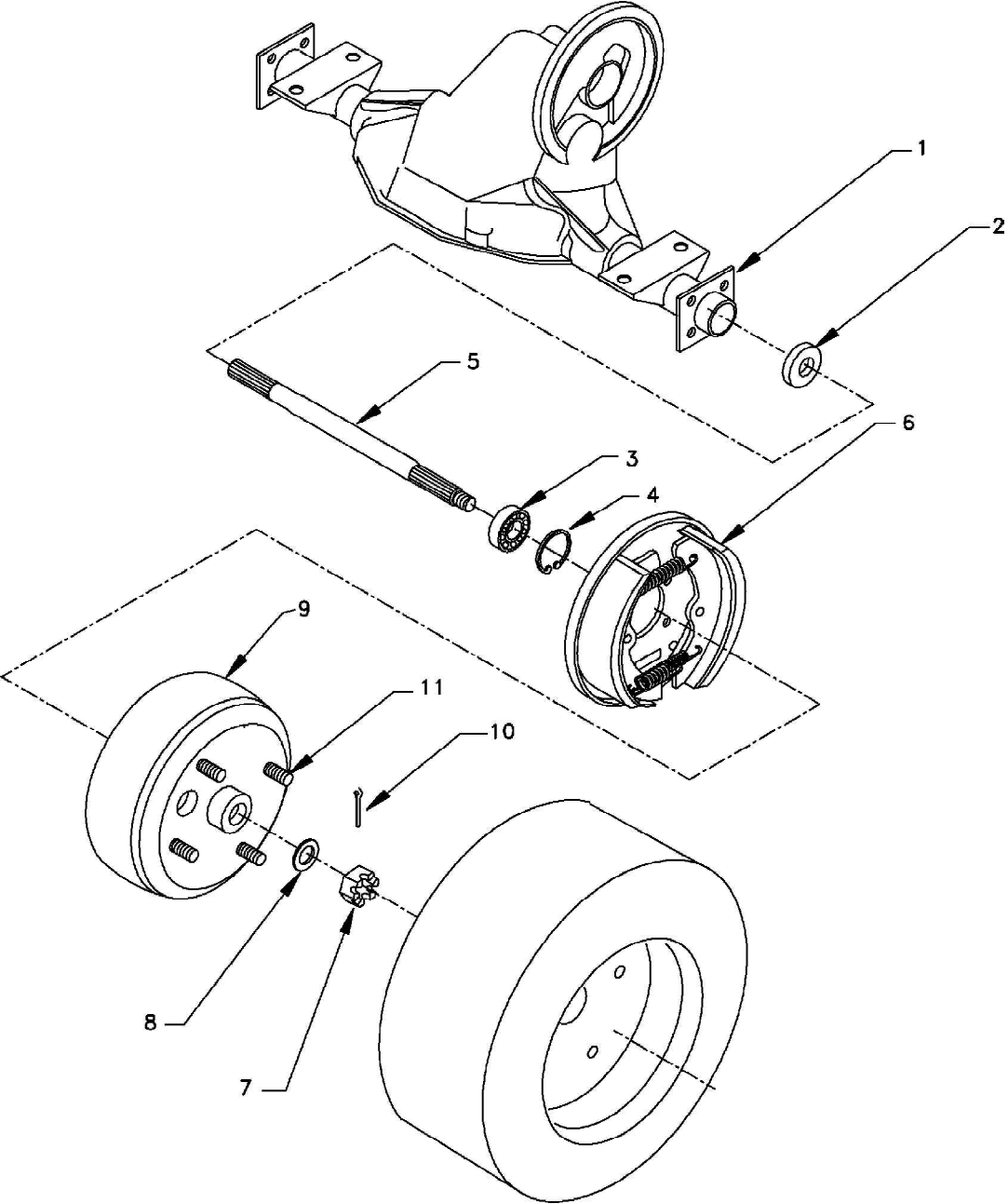



**SS5-36, SS5-46 and MX-600 Rear Axle(P/N 4S-150-10)**

ITEM#	PART#	DESCRIPTION	QTY
1	41-281-10	Differential Assy	1
2	45-303-20	Seal	2
3	80-480-20	Axle Bearing	2
4	88-840-13	Internal Snap Ring	4
5	41-126-99 41-126-98	Right Axle Shaft Left Axle Shaft	1 1
6	41-344-99 41-344-98	Right Brake Left Brake	1 1
7	88-199-85	Slotted Hex Nut	2
8	88-188-61	5/8" SAE Washer	2
9*	41-518-00 41-518-01 41-518-02	Brake Drum/hub up to November, 2002 Brake drum after November, 2002 Hub November, 2002	2 2 2
10	88-527-11	1/8" X 1" Cotter Pin	2
11	66-610-28	Wheel Stud	4

\*- Both brake drum syles are interchangeable.

ILLUSTRATED PARTS

DIFFERENTIAL (SS5-34)

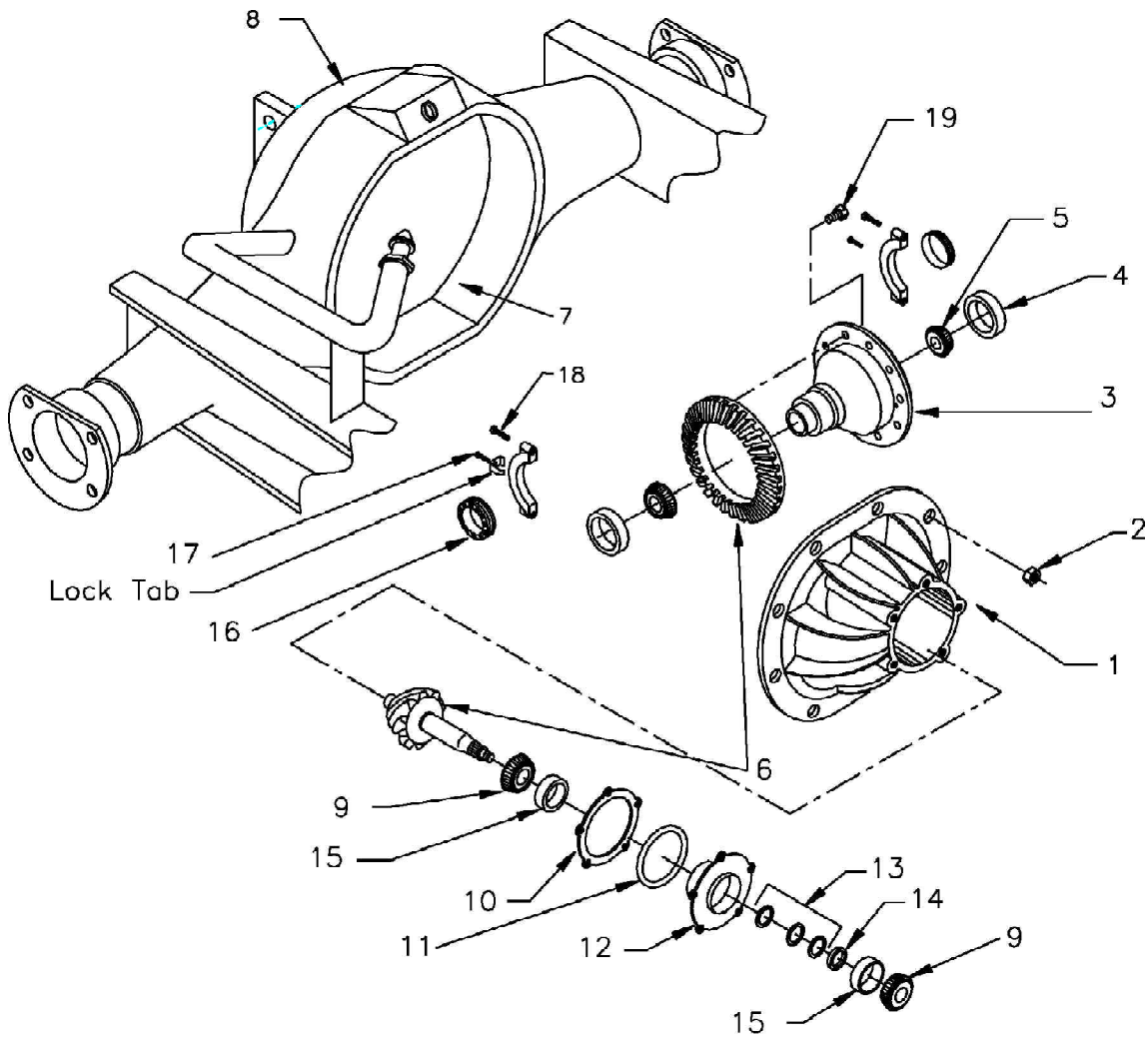

SS534 3RD MEM III Ports.DWG



### 3rd Member and Axle Assembly

ITEM#	PART#	DESCRIPTION	QTY
1	41-709-00	3rd member Housing (1.628 ID Carrier Bearing)	1
	41-710-00	3rd member Housing (1.784 ID Carrier Bearing)	1
2	88-119-80	3/8" NF Nut	14
3	41-712-00	Differential Assembly (1.628 ID Carrier Bearing)	1
	41-713-00	Differential Assembly (1.784 ID Carrier Bearing)	1
4	80-127-00	Carrier Bearing Race, (For 1.628 ID Carrier Bearing)	2
	80-128-00	Carrier Bearing Race, (For 1.784 ID Carrier Bearing)	2
5	80-511-00	Carrier Bearing (1.628 ID Carrier Bearing)	2
	80-512-00	Carrier Bearing (1.784 ID Carrier Bearing)	2
6	31-235-00	Ring and Pinion Gear Set (2.69-2.75)	1
7	41-997-00	Oil Plug	3
8	41-296-00	Rear End Housing	1
9	80-554-00	Pinion Bearing	2
10	41-711-00	Pinion Housing Shim	1
11	80-702-00	O-Ring	1
12	44-340-90	Pinion Housing Shim	1
13	16-419-00	.002 Shim (Add Shims As Needed)	*
	16-420-00	.010 Shim (Add Shims As Needed)	*
	16-411-00	.005 Shim (Add Shims As Needed)	*
14	16-415-00	Spacer	1
15	80-125-00	Pinion Bearing Race	2
16	41-707-00	Differential Bearing Adjuster Nut (For 80-511-00)	2
	41-707-50	Differential Bearing Adjuster Nut (For 80-512-00)	2
17	88-080-04	5/16" X 3/8" NC Hex Bolt	2
18	88-140-16	1/2" X 2" Hex Bolt	2
19	96-243-00	7/16" X 7/8" Hex Bolt (Locking Head)	10
Not Shown	45-339-00	Oil Seal, Pinion Shaft	1
	41-701-00	Roll Pin, Spider Gear Shaft	1

ILLUSTRATED PARTS

DIFFERENTIAL (SS5-36, SS5-46 AND MX-600)

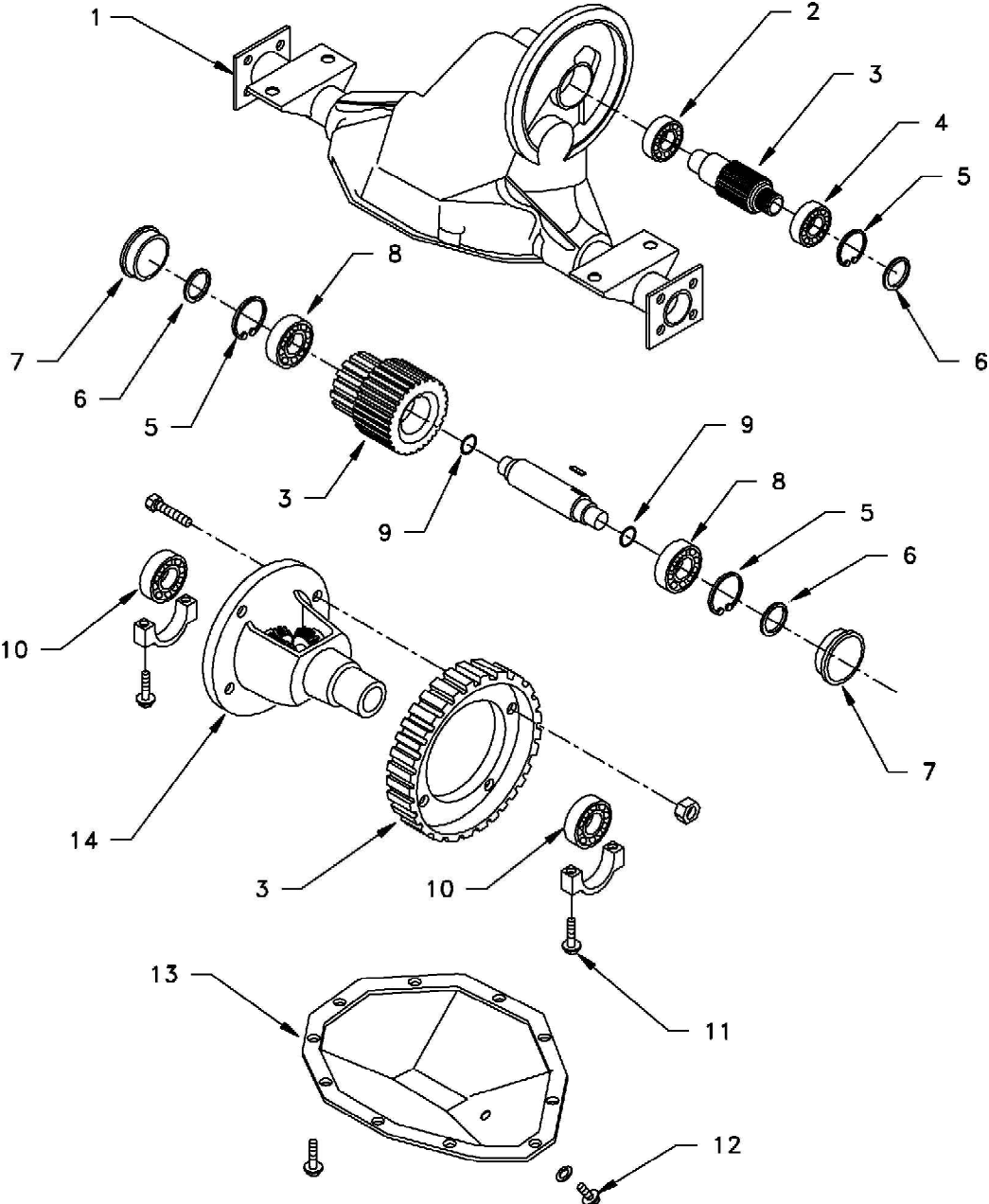





### SS536, SS5-49 & MX-600 Differential Assy

ITEM#	PART#	DESCRIPTION	QTY
1	41-280-10	Differential Housing Assy	1
2	80-480-10	Pinion Bearing	2
3	31-265-00	Gear Set	1
4	80-480-15	Shaft Bearing	1
5	88-840-12	Snap Ring	3
6	80-715-10	O-Ring	3
7	41-973-00	Cup Plug	2
8	80-480-01	Bearing	2
9	80-715-00	O-Ring	2
10	80-408-00	Carrier Bearing	2
11	96-330-10	Bearing Cap Bolt	4
12	41-127-94	Fill Plug	1
13	41-127-64	Carrier Cover	1
14	41-716-00	Differential Case Assy	1

ILLUSTRATED PARTS

# SS5-36, SS5-46 DIFFERENTIAL FRAME

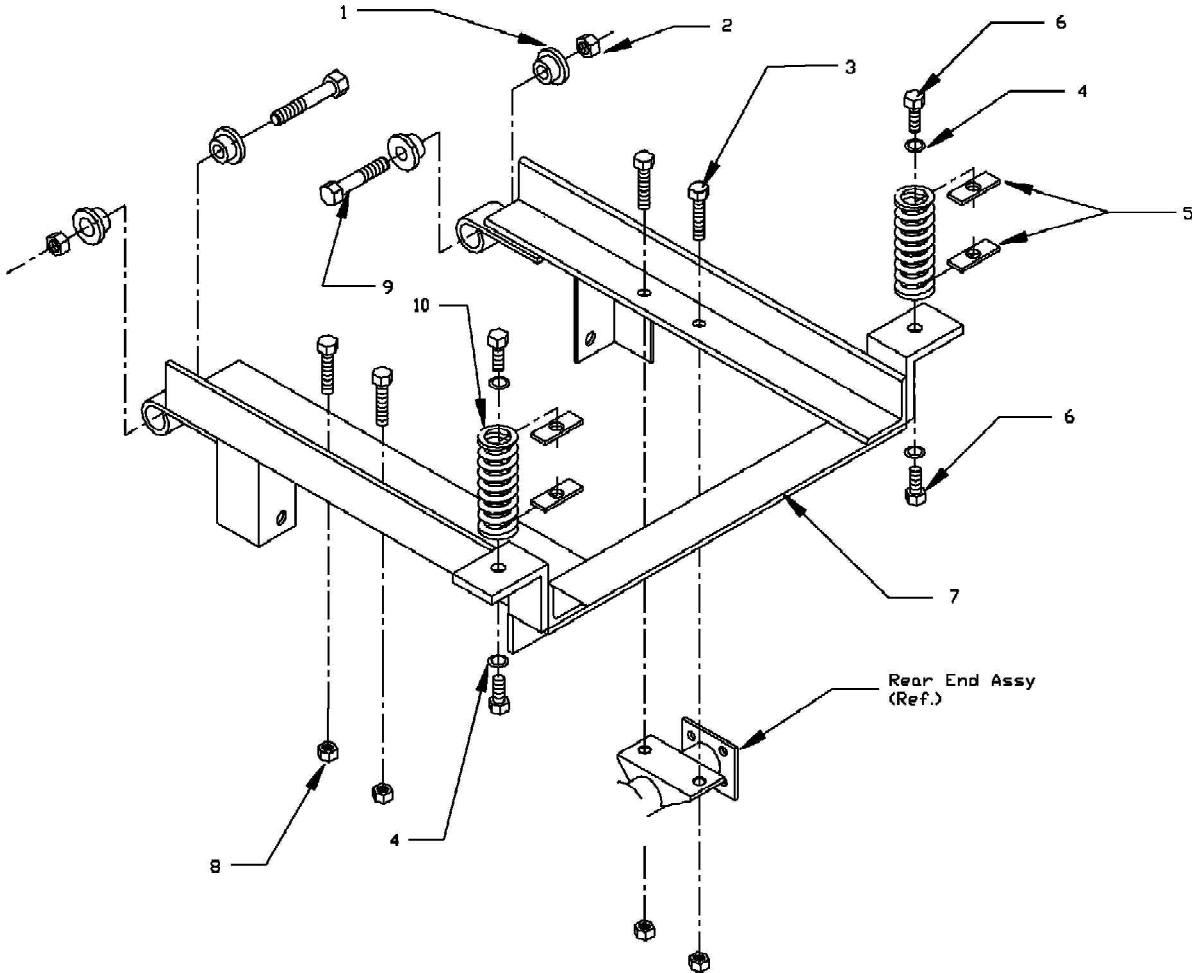



### SS536, SS5-46 Differential Frame

ITEM#	PART#	DESCRIPTION	QTY
1	98-601-00	Rubber Grommet, 1/2" ID	4
2	88-149-81	1/2" Locknut	2
3	88-100-15	1/2" X 1-3/4" Bolt	4
4	88-108-62	3/8" Lockwasher	4
5	85-141-00	Spring Clip	4
6	88-100-11	3/8" NC X 1" Bolt	4
7	00-536-01	Drive Frame	1
8	88-149-81	1/2" Locknut	4
9	96-240-00	1/2" X 4" Bolt	2
10	85-140-00	Spring	2

ILLUSTRATED PARTS

DECK AND VISE ASSY (MX-600)

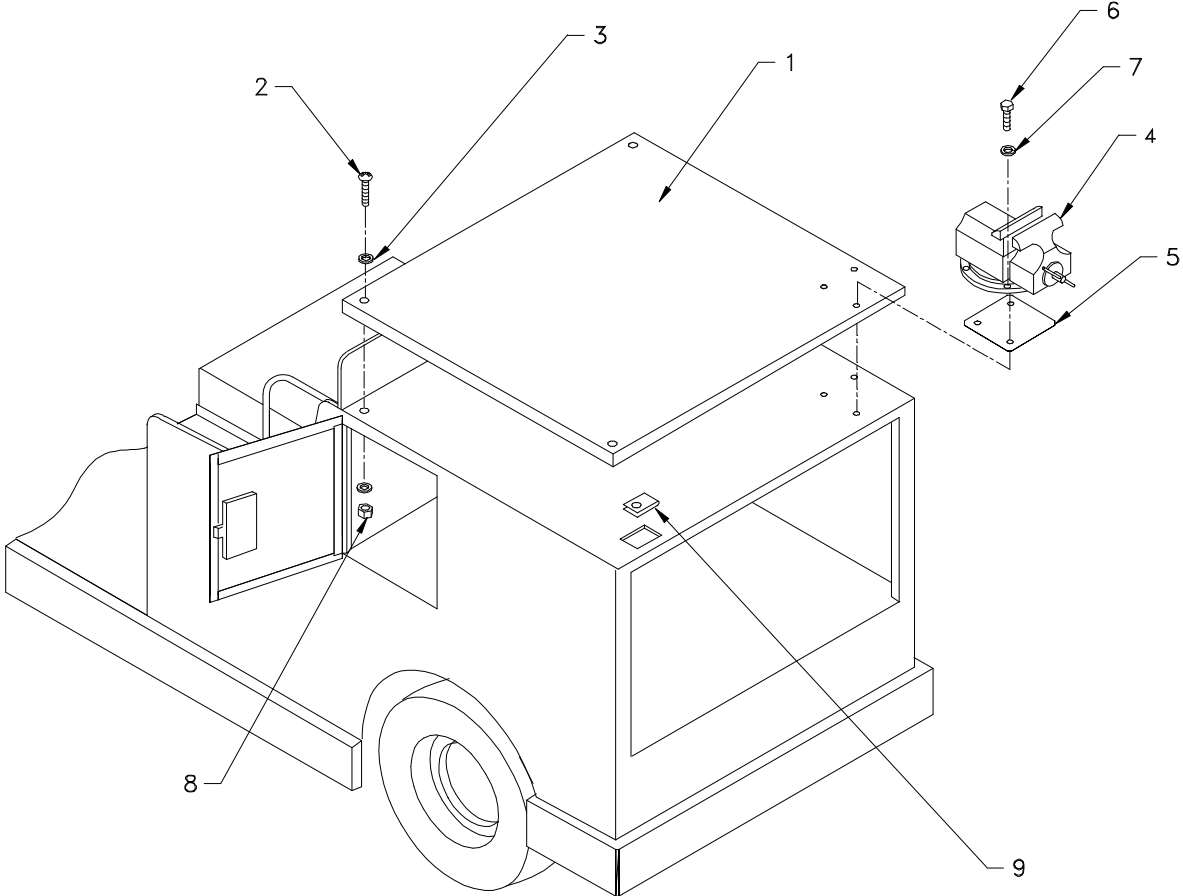

MX Vise.dwg



### MX-600 Deck and Vise Assy

ITEM#	PART#	DESCRIPTION	QTY
1	90-408-20	30" X 27-1/2" Deckboard	1
2	88-065-13	1/4" NC X 1-1/4" Truss Head Screw	3
3	88-068-61	1/4" SAE Washer	5
4	97-840-01	4-1/2" Jaw Width Vise	1
5	00-380-01	Vise Mount Plate	1
6	88-100-15	3/8"NC X 1-3/4" Hex Head Bolt	3
7	88-108-62	3/8" Lockwasher	3
8	88-069-81	1/4" Locknut	2
9	97-211-20	1/4" NC Retainer Nut	1
Not Shown	91-340-21	Tool Box Lock	1
	91-340-26	Keys for Toolbox Locks	1
	00-300-08	Steel Deck Cover	1

ILLUSTRATED PARTS

TOOLBOX ASSY (MX-600)

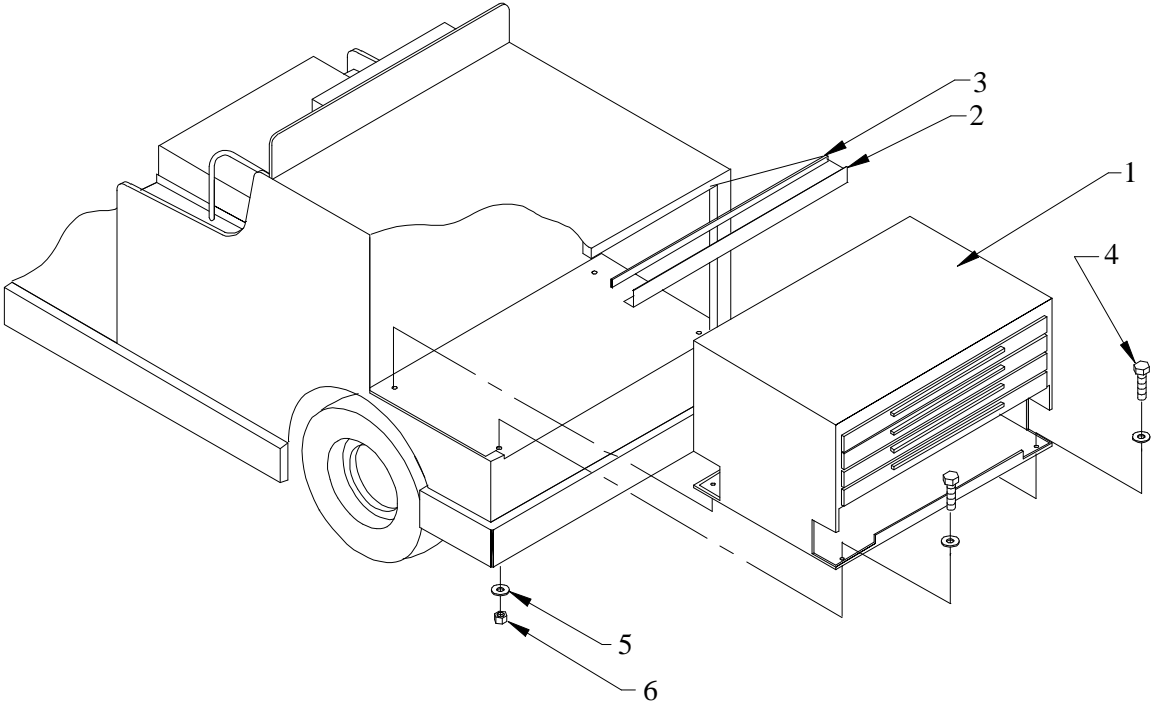



### MX-600 Tool Box

ITEM#	PART#	DESCRIPTION	QTY
1	91-340-25	Tool Chest	1
2	00-300-02	Trim	1
3	94-400-32	Double Sided Tape	3 ft
4	88-140-11	1/2"NC X 1" Hex Head Bolt	4
5	88-148-61	1/2" SAE Washer	8
6	88-159-84	1/2"NC Locknut	4
Not Shown	91-340-21	Tool Box Lock	1
	91-340-26	Keys for Toolbox Locks	1
	00-300-08	Steel Deck Cover	1

ILLUSTRATED PARTS

BATTERY

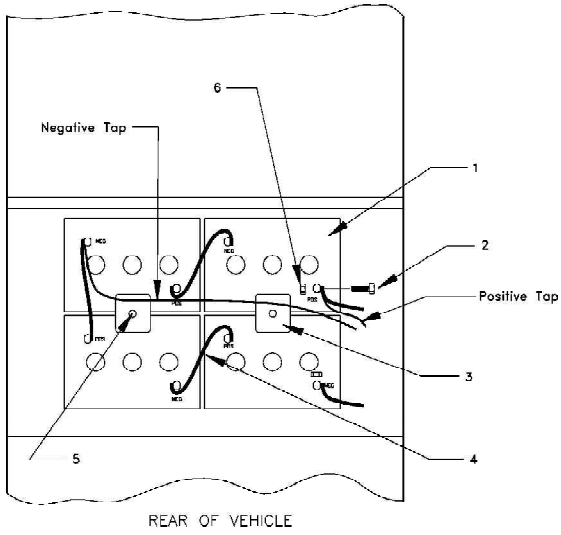

SS 5-34

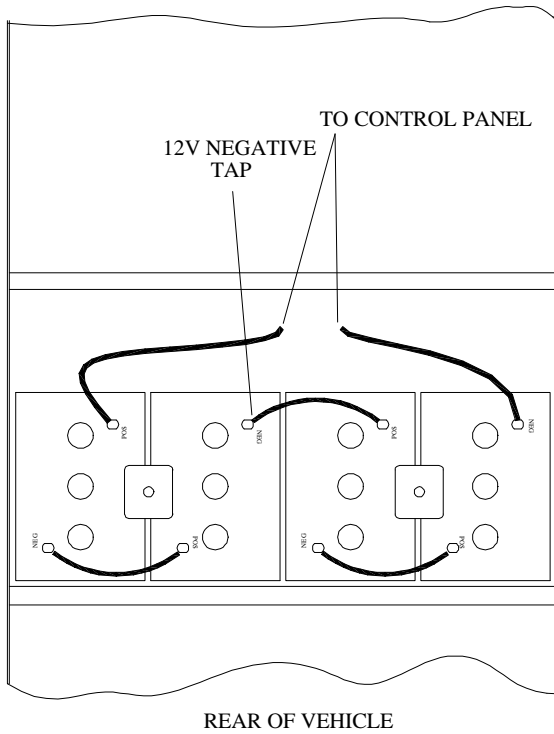

SS5-36, SS5-46 and MX 6-00





## Batteries

ITEM#	PART#	DESCRIPTION	QTY
1	77-042-50	Battery, 217AH, 105min	4
	77-047-00	Battery, 244AH, 145min	4
	77-044-00	Battery, 230AH, 105min	4
	77-042-80	Battery, Moist Dry, 217AH, 105min	4
	77-047-80	244AH, 145min, Dry Charge	4
2	88-081-12	5/16" NC X 1" Bolt	8
3	50-250-00	Battery Hold Down	2
4	50-243-10	Battery Hold Down Rod (For #3)	2
5	75-231-00	Battery Jumper 10-1/4" Long	3
6	88-089-80	5/16" NC Nut	2

ILLUSTRATED PARTS

BRAKE ASSY (SS5-34)

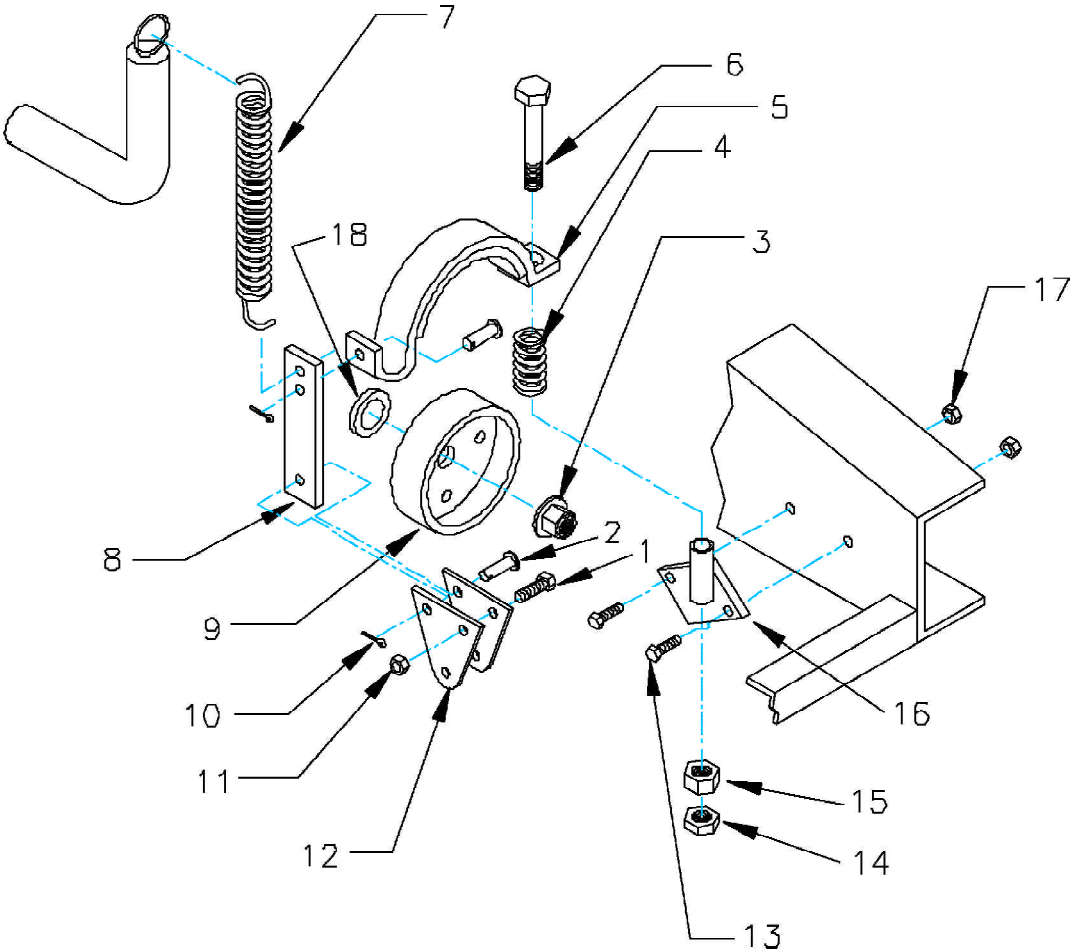



### Mechanical Brake Band Assy (SS5-34)

ITEM#	PART#	DESCRIPTION	QTY
1	88-100-11	3/8" NC X 1-3/4" hex Head Cap Screw	1
2	96-771-00	3/8" X 3/4" Clevis Pin	2
3	97-250-00	3/4"-20 Extra Fine Pinion Nut	1
4	85-060-20	5/8" OD X 2-1/2" Compression Spring	1
5	41-660-60	Brake Half Band	1
6	96-245-10	1/2" NC X 5" hex Head Cap Screw	1
7	85-270-00	1-1/4" OD X 4-3/8" Extension Spring	1
8	50-661-00	Brake Lever Bar	1
9	41-532-00	Brake Drum	1
10	88-517-11	3/32" X 1" Cotter Pin	2
11	88-089-81	5/16"NC Locknut	4
12	50-662-00	Brake Lever	1
13	88-080-11	5/16" NC X 1" Hex Head Cap Screw	2
14	88-159-82	1/2"NF Jam Nut	1
15	88-159-84	1/2"-20 NF Locknut	1
16	41-380-10	Brake Mounting Bracket	1
17	88-089-81	5/16" NC Locknut	2
18	45-339-00	Pinion Seal	1

ILLUSTRATED PARTS

REAR BRAKE (SS5-36, SS5-46 AND MX-600)

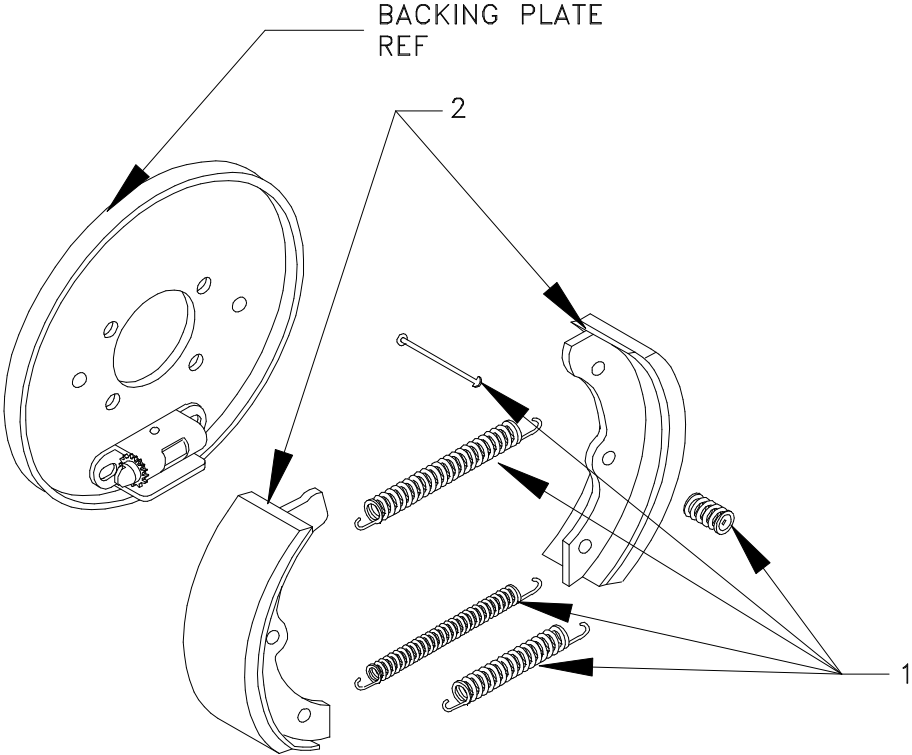

brake shoes and backing plate v numbers.dwg



**Rear Brake (SS5-36, SS5-46 and MX-600)**

ITEM#	PART#	DESCRIPTION	QTY
1	85-344-60	Spring Kit	1
2	41-634-00	Brake Shoes (Shows 1 Set)	2
	41-344-98	Complete Brake Assembly, Left	1
	41-344-99	Complete BRake Assembly, Right	1

# PMC CONTROL PANEL

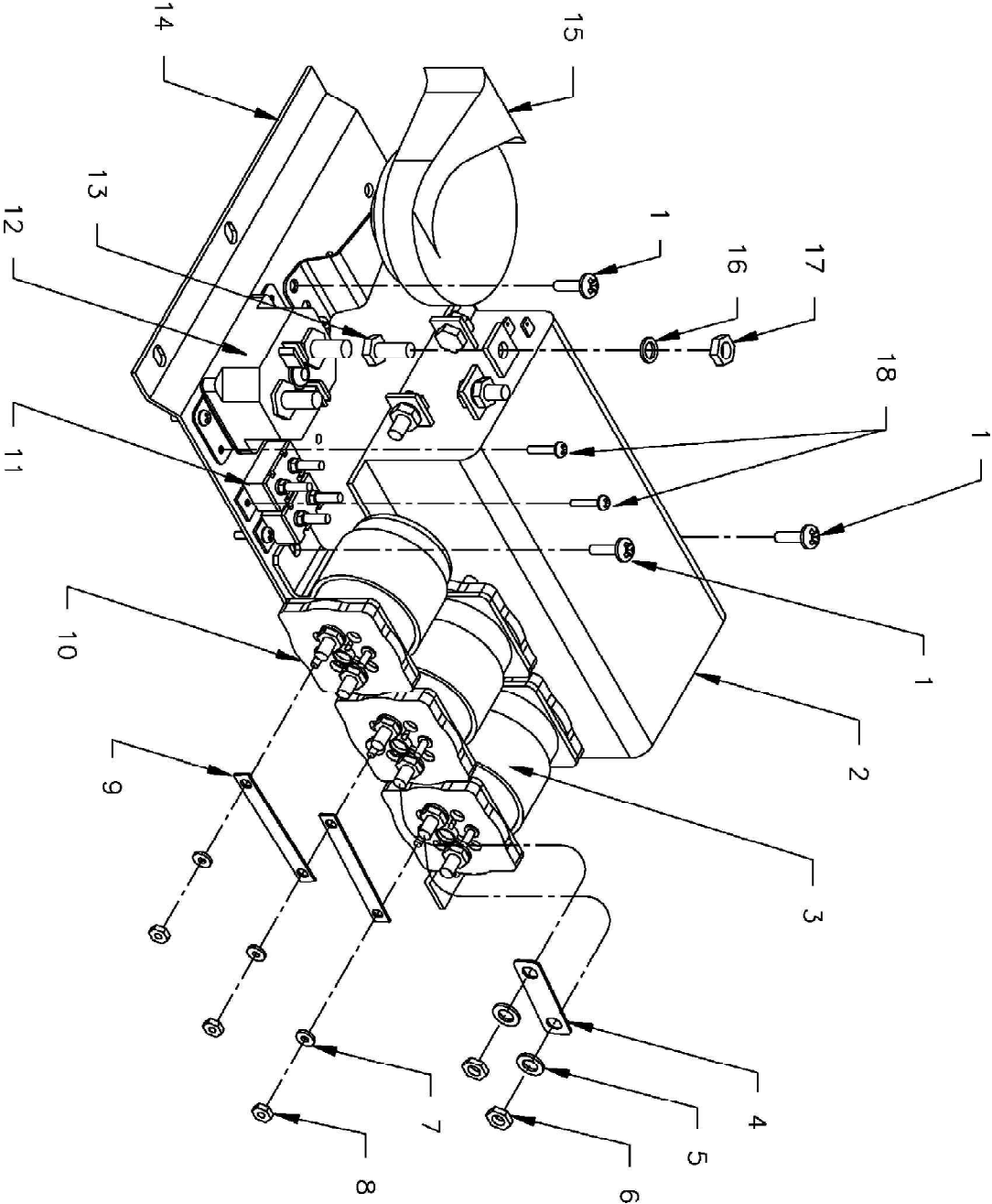

**PMC Control Panel**

ITEM#	PART#	DESCRIPTION	QTY
1	88-838-06	#14 X 1/2" Pan Head Screw	4
2	62-204-00	PMC Controller	1
3	72-501-43	Forward/Reverse Solenoid	2
4	61-838-41	5/8" X 1-1/2" Bus Bar	2
5	88-088-62	5/16" Lockwasher	10
6	88-099-91	5/16" Nut	10
7	88-048-62	#10 Lockwasher	6
8	88-049-80	10-32 Nut	6
9	61-838-42	3/8" X 2-5/8" Bus Bar	2
10	72-501-42	ISO Solenoid	1
11	79-840-00	10-Amp Circuit Breaker	2
12	79-844-00	135-Amp Auto Reset Circuit Breaker	1
13	88-080-11	5/16" X 1" Hex Head Cap Screw	4
14	01-534-89	Control Panel Mount (SS5-34 & SS5-36)	1
	00-300-03	Control Panel Mount (MX-600)	1
15	73-004-20	12V Horn	1
16	88-088-62	5/16" Lockwasher	4
17	88-089-80	5/16" Hex Nut	4
18	88-818-06	#8 X 1/2" Pan Head Screw	7

**Harnesses and Panel Assy**

ITEM#	PART#	DESCRIPTION	QTY
Not Shown	75-148-43	Control Panel Harness (MX-600)	1
	75-148-25	Control Panel Harness (SS5-34 & SS5-36)	1
	75-149-25	Power Harness (All)	1
	62-015-07	Control Panel Assy(MX-600)	1
	62-015-00	Control Pnl Assy (SS5-34 & SS5-36)	1

ILLUSTRATED PARTS

# BATTERY CHARGER

## LESTER PORTABLE CHARGER

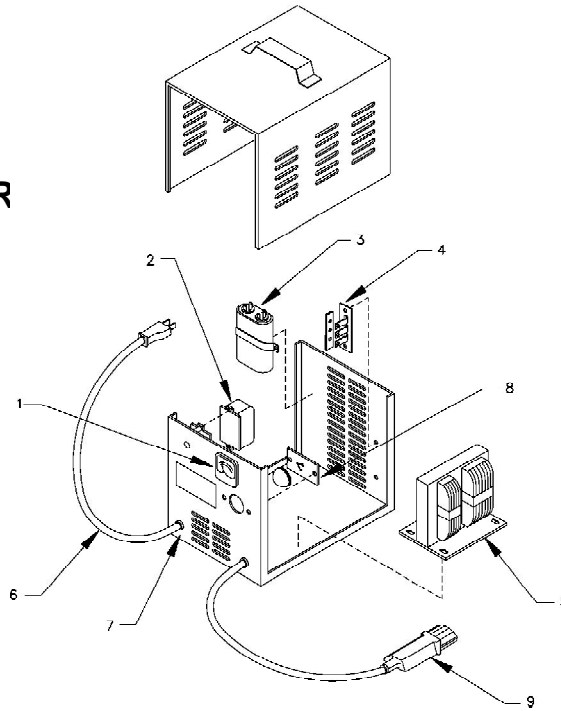

## LESTER BUILT-IN CHARGER

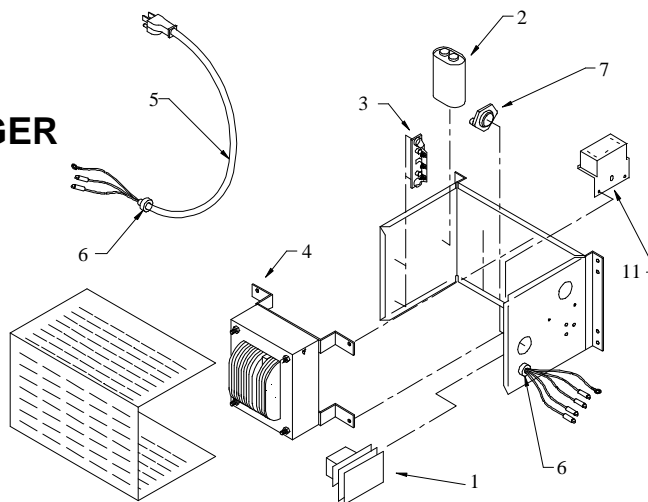

## SIGNET CHARGER REFER TO PARTS APPENDIX A AT THE END OF THIS SECTION





**Portable Battery Charger 24-Volt 25-Amp, Model 13110 (79-301-10)**

ITEM#	PART#	DESCRIPTION	QTY
1	79-851-10	Ammeter	1
2	79-805-64	Timer	1
3	79-902-00	Capacitor	1
4	79-749-13	Heat Sink With Diodes	1
5	79-644-30	Transformer	1
6	79-575-10	AC Cord Set with Plug	1
7	79-831-00	Fuse Assembly	1
8	79-530-00	Bushing for Cords	2
9	79-566-10	DC Cord	1
11	Not available		

**Built-In Battery Charger 24-Volt 25-Amp, Model 10505 (79-301-05)**

ITEM#	PART#	DESCRIPTION	QTY
1	79-805-66	Timer	1
2	79-902-00	Capacitor	1
3	79-749-13	Heat Sink With Diodes	1
4	Special Order	Transformer	1
5	79-575-30	AC Cord Set with Plug	1
6	79-530-00	Bushing for Cords	2
7	79-831-00	Fuse Assembly	1
11	Not available		

**Built-In Battery Charger 24-Volt 25-Amp, Model 22730 (79-303-05)**

ITEM#	PART#	DESCRIPTION	QTY
1	79-805-66	Timer	1
2	79-902-00	Capacitor	1
3	79-749-13	Heat Sink With Diodes	1
4	Special Order	Transformer	1
5	79-575-30	AC Cord Set with Plug	1
6	79-530-00	Bushing for Cords	2
7	79-831-00	Fuse Assembly	1
11	79-809-60	Interlock Relay Starting serial #151285	1

ILLUSTRATED PARTS

TIRE AND WHEEL

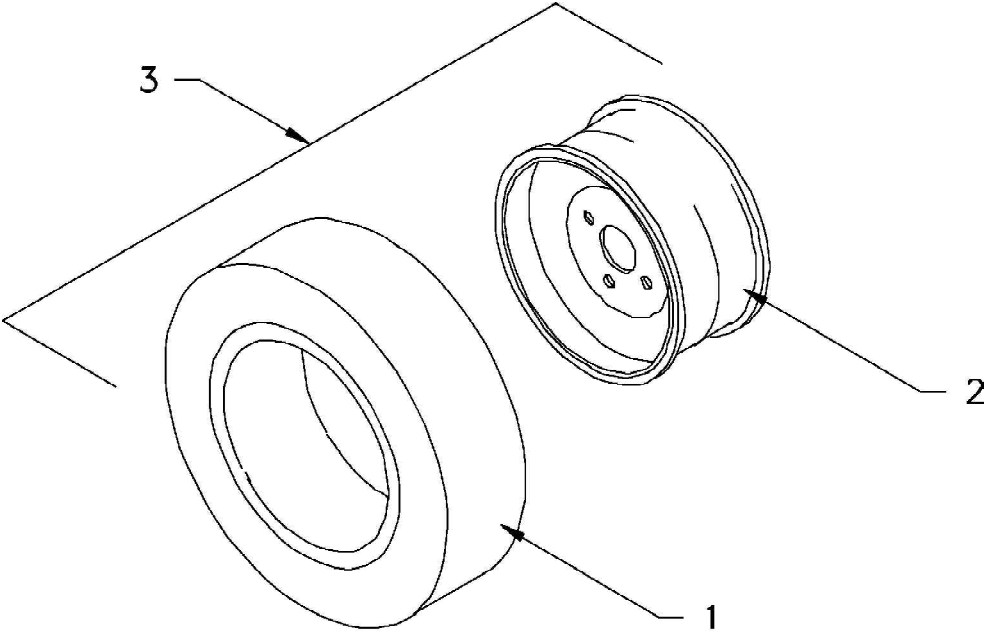

TIRE AND WHEEL ILLUSTR PARTS.DWG



## Tire and Wheel Assemblies

ITEM#	PART#	DESCRIPTION
<b>TIRES</b>		
1	10-075-00	4.80 X 8 Load Range B Tubeless Tire
	10-074-00	4.80 X 8 Mantoter
	10-261-00	16-1/4 X 4 X 11-3/4 Solid Tire
<b>RIMS</b>		
2	12-022-10	Rim With 4 hole Pat. for 4.80 X 8 Tire (SS5-36, SS5-46 & MX-600)
	12-043-10	Split Rim W/4 hole Pat. for 4.80 X 8 Tire (SS5-36, SS5-46 & MX-600)
	12-012-00	Rim With 5 hole Pat. for 4.80 X 8 Tire (SS5-34)
	12-054-00	Iron Rim With 5 hole Pat. for 16-1/4 X 4 X 11-1/4 Tire (SS5-34)
<b>TIRE and RIM</b>		
3	13-734-00	4.80 X 8 LR'B' Tire and Split Rim(Standard on SS5-34)
	13-734-11	4.80 X 8 LR'B' Tire and Split Rim(SS5-34)
	13-734-41	4.00 X 8 Non Marking Tire and Split Rim (SS5-34)
	13-734-12	4.80 X 8 LR'B' Tire and Split Rim (SS5-36, SS5-46 & MX-600)
	13-734-21	4.80 X 8 Tire and Split Rim (Standard on SS5-36, SS5-46 & MX-600)
	13-954-10	16-1/4 X 4 X 11-3/4 Solid Tire and Iron Rim(SS5-34)
	13-734-50	4.80 X 8 Mantoter Tire and Split Rim (SS5-36, SS5-46 & MX-600)
<b>FRONT TIRE, RIM and HUB</b>		
Not	13-001-00	4.80 X 8 Rim & 4"Front Hub, W/ Bearings & Seals(Rim Only)
Shown	13-576-10	4.80 X 8 Tubeless Tire, LR 'B', W/ Bearings, Split Rim & 4"Front Hub
	12-120-00	5 Stud Center Hub (Optional) SS5-34
	12-120-10	4 Stud Center Hub (Optional) MX-600, SS5-36
	12-124-15	Front Hub, SS5-46
	11-030-00	Tube
	13-989-00	Valve Stem

ILLUSTRATED PARTS

SEAT CUSHIONS

**SS5-34**

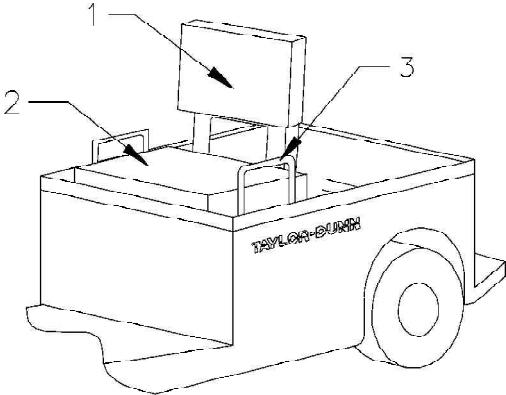

**SS5-36, SS 5-46**

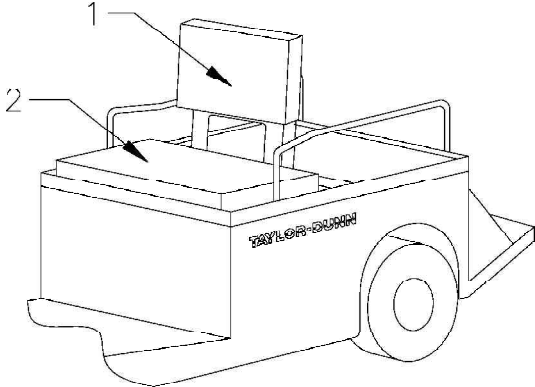

**MX-600**

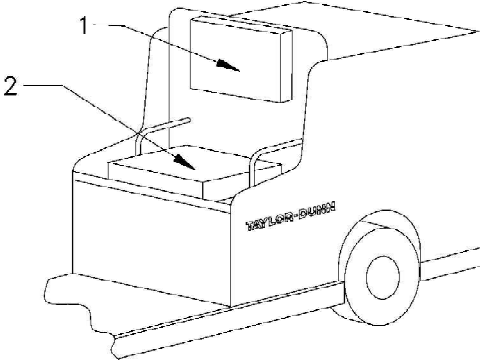



### Seat Cushions

ITEM#	PART#	DESCRIPTION	QTY
<b>SS5-34</b>			
1	90-144-00	Backrest (Optional)	1
2	90-166-00	Seat Cushion	1
3	02-534-25	Hip Restraint	2
<b>SS5-36, SS5-46</b>			
1	93-004-00	Backrest/2nd Passenger Seat	1
2	93-005-00	Seat Cushion	1
<b>MX-600</b>			
1	90-144-00	Backrest	1
2	93-006-00	Seat Cushion	1

ILLUSTRATED PARTS

DECALS

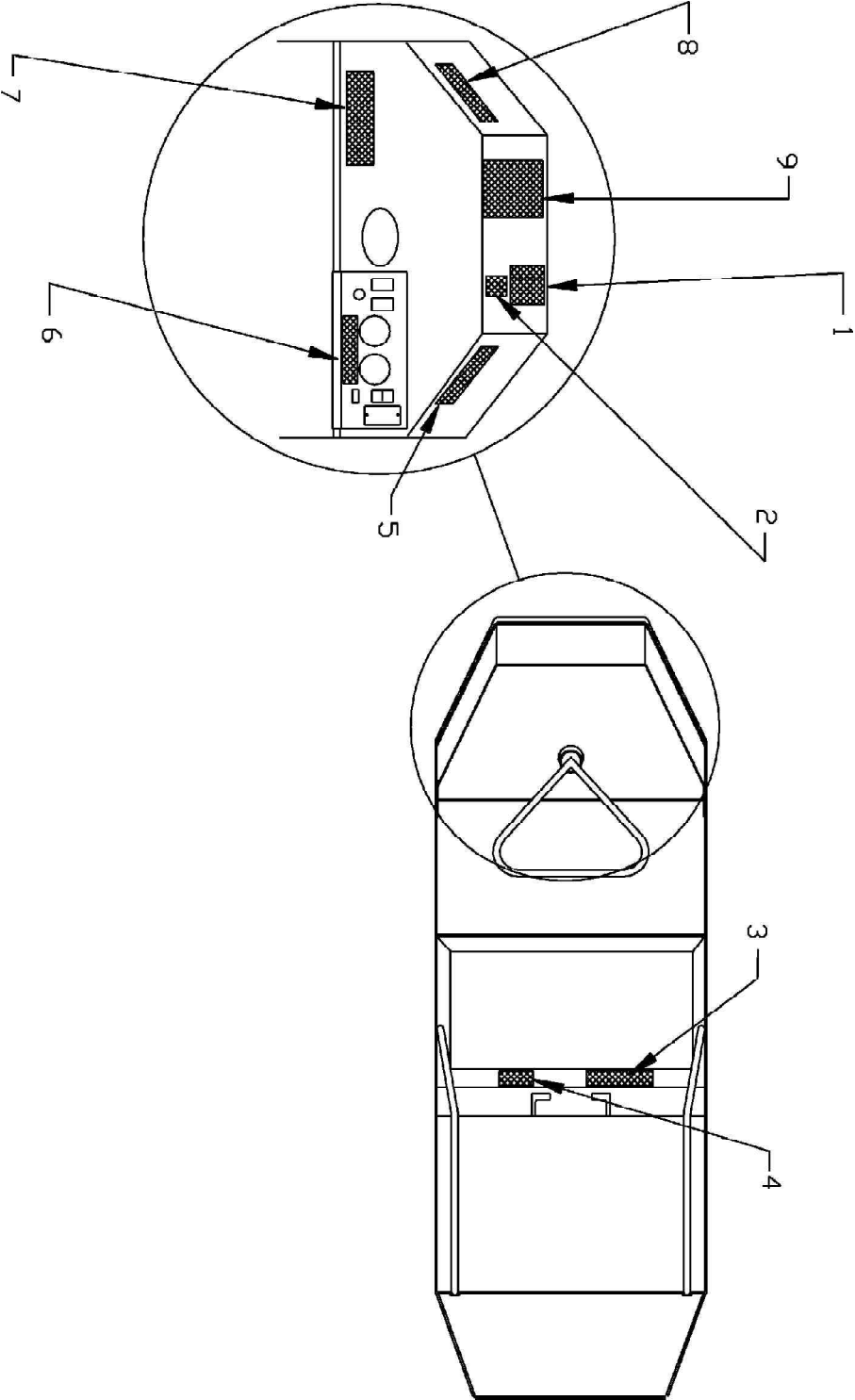



## Decals

ITEM#	PART#	DESCRIPTION	QTY
1	94-373-10	Vehicle Data Decal	1
2	94-333-00	F-M Approved Decal	1
3	94-385-00	Battery Warning Decal	1
4	94-319-00	Battery Disconnect Decal	1
5	94-384-01	Not A Motor Vehicle Decal (Domestic)	1
	94-384-04	Traffic Standards Notice Decal (Export)	1
6	94-383-00	Console Decal	1
7	94-384-00	Park Brake Decal	1
8	94-386-01	Roll Over Warning Decal (MX-600 Only)	1
9	94-309-50	Park Brake Warning Decal	1
10	94-313-20	Safety Warning Decal	1
Not Shown	94-386-00	Prevent Damage to Tools	1

NOTE: Part Number 94-386-00 and 94-386-011 is applied only to the MX-600. The 94-386-00 decal is placed just behind the seat and centered.

ILLUSTRATED PARTS

MIRRORS OPTION

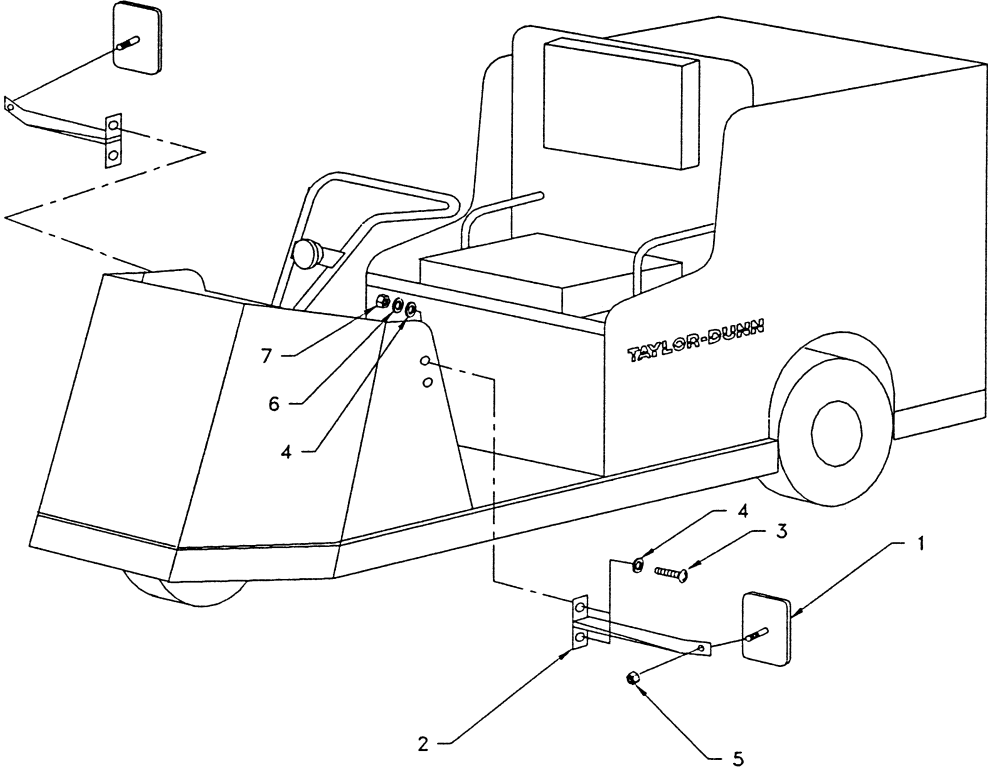





### Mirror Option

ITEM#	PART#	DESCRIPTION	QTY
1	92-201-00	4-1/2" X 8-1/2" Mirror (Rt or Lt Side)	1
2	92-202-00	Mirror Bracket (Rt or Lt Side)	1
3	88-065-08	1/4"NC X 5/8" Truss Head Screw	4
4	88-068-60	1/4" Washer	8
5	88-069-87	1/4" Keps Nut	1
6	88-068-62	1/4" Lockwasher	4
7	88-069-83	1/4" Acorn Nut	4

NOTE: All quantities are for a single mirror. To order parts for two mirrors double all quantities.

ILLUSTRATED PARTS

# STROBE AND STOP LIGHT OPTION

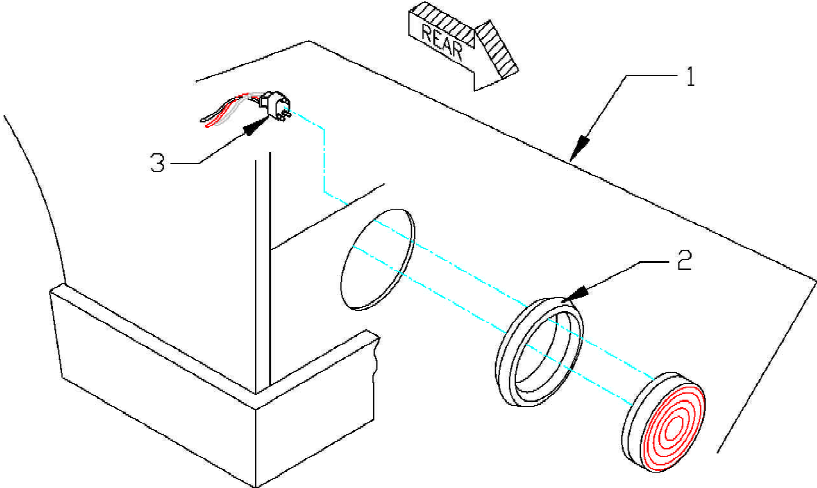

SS-MX Round Tail Light.DWG

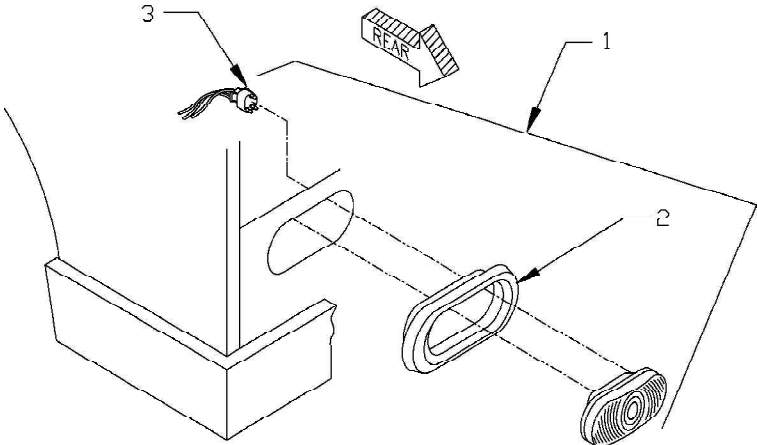

Oval tail-light for MX600 and SS.DWG

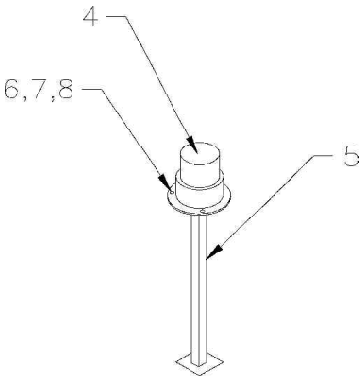



### Strobe and Stop Light Option

ITEM#	PART#	DESCRIPTION	QTY
1	72-022-00	4" Round Stop & Tail Light Assy	2
	72-025-00	Oval Stop & Tail Light Assy Complete	2
2	72-022-51	Round Rubber Grommet	2
	72-025-51	Oval Rubber Grommet	2
3	72-022-52	Pig Tail (For Both Stop & Tail Lights)	2
4	72-023-20	Strobe Light, 12-48 Vdc, Amber	1
5	72-023-32	Pole for Strobe Light (MX-600 Only)	1
6	88-025-06	8-32 X 1/2" Truss Head Machine Screw	3
7	88-028-62	#8 Lockwasher	3
8	88-029-80	8-32 Hex Nut	3
Not Shown	75-106-13	Wire Harness (For Strobe Light)	1
	98-603-00	3/8" ID Rubber Grommet (For Harness)	1
	72-023-21	Flash Tube for Strobe Light	1

NOTE: 72-022-00 4-inch Round Light is installed on the SS5-34 and the 72-025-00 Oval Light is installed on the SS5-36 and MX-600.

NOTE: All strobe light information is for the MX-600 at the time of printing no strobe light information was available. However the part number 72-023-21 is the flash tube for all strobe lights.

ILLUSTRATED PARTS

# HEADLIGHT

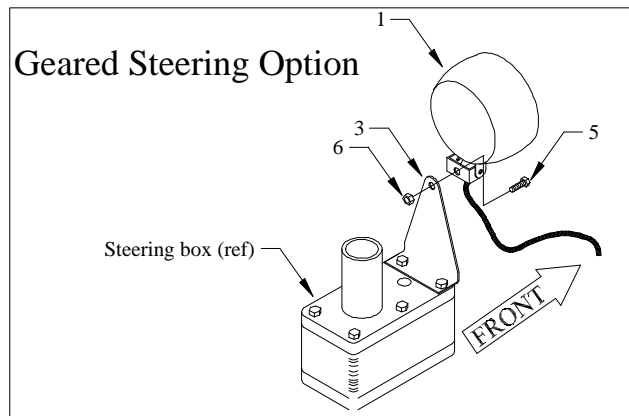
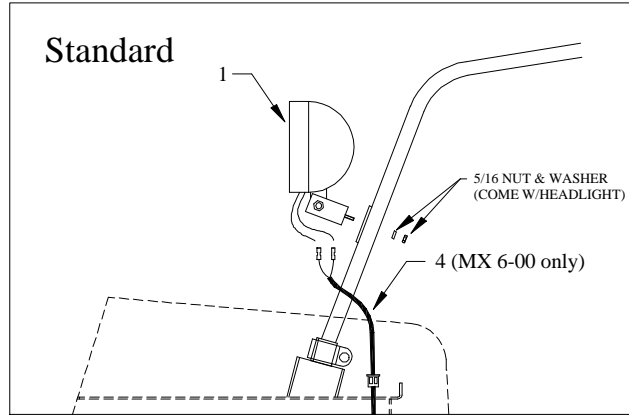

#2 - SS 5-34, SS 5-36, SS 5-46



#2 - MX 6-00



### Headlight

ITEM#	PART#	DESCRIPTION	QTY
1	72-005-00	Heallight	1
2	71-039-11 71-100-00	Switch, SS 5-34, SS 5-36, SS 5-46 Switch, MX 6-00	1 1
3	71-505-05	Mount, geared steering option	1
4	75-166-35	Harness, MX 6-00	1
5	88-100-09	3/8NC x 3/4 Hex bolt	1
6	88-109-87	3/8NC KEPS nut	1

 **TAYLOR-DUNN**

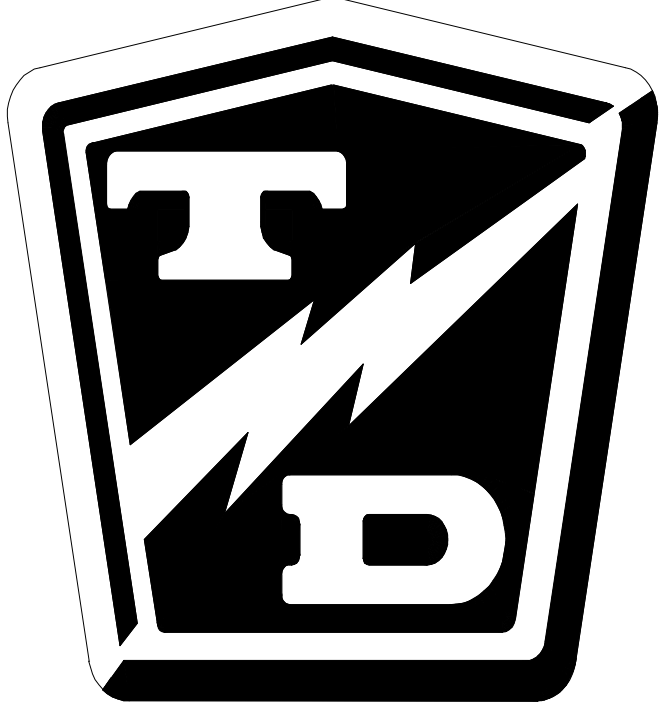

Parts Appendix A

---



ILLUSTRATED PARTS

# SIGNET CHARGER



NOTE: The harness connectors are not included with the charger. When replacing the charger order 2 each of the following:

PART #	DESCRIPTION
75-318-20	Butt splice
75-320-51	Knife connector



Signet® Charger			
ITEM #	PART #	DESCRIPTION	QTY
	79-303-40	Charger assembly (see note on facing page)	1
	79-575-60	Replacement cover w/AC cord and gasket	1

Note: There are no user serviceable components inside the charger

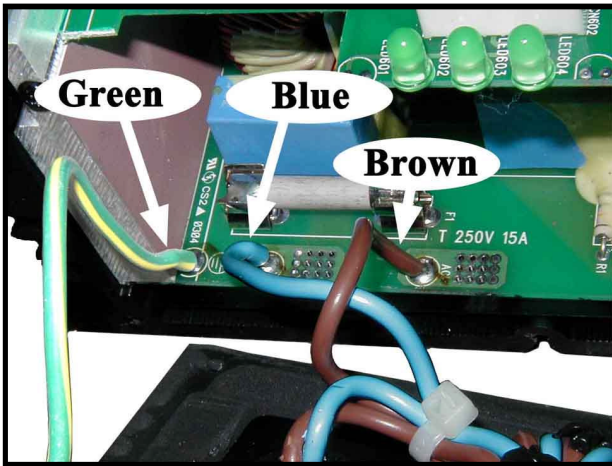

AC Wire Connections

**TAYLOR-DUNN**

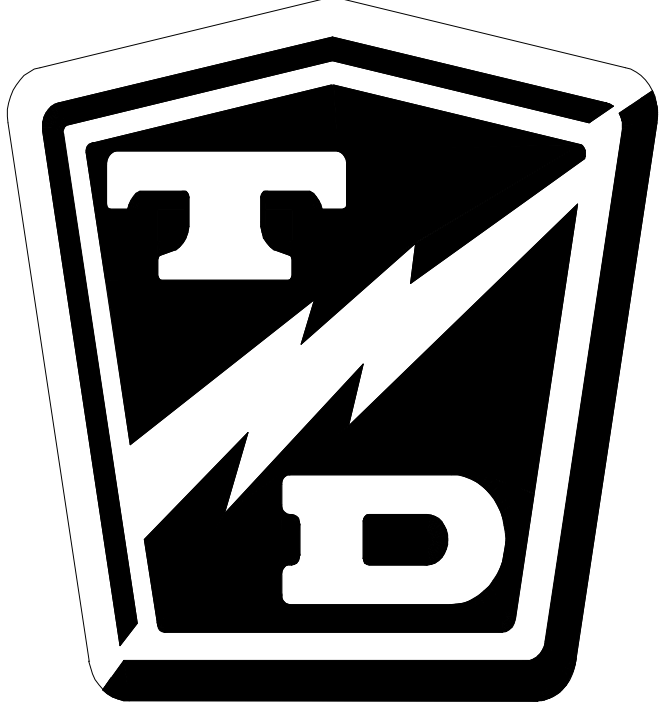



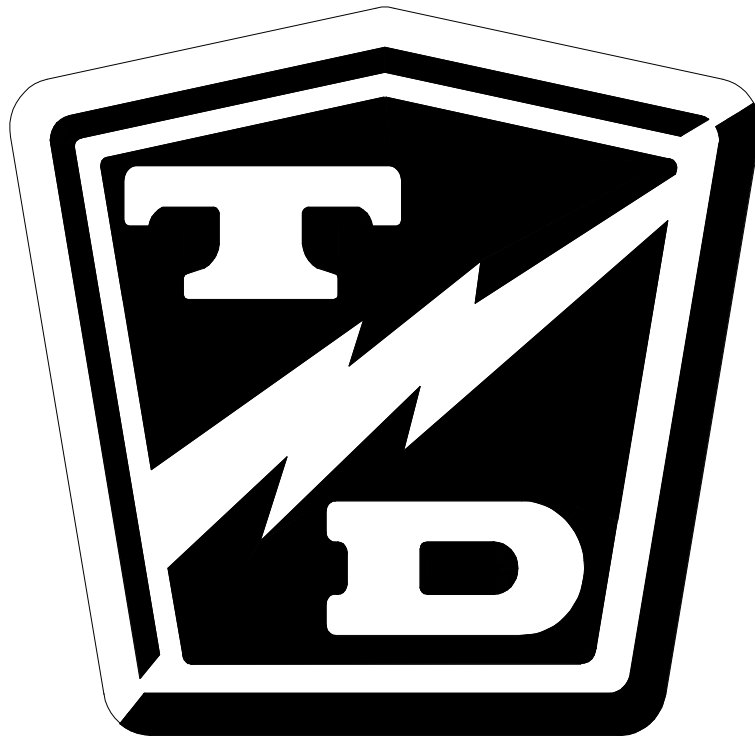

Taylor-Dunn® Mfg.  
2114 W. Ball Rd.  
Anaheim, CA 92804  
(800)-688-8680  
(714) 956-4040  
(FAX) (714) 956-0504

Mailing Address:  
P.O. Box 4240  
Anaheim, California 92803

***Visit our Website:***  
**[www.taylor-dunn.com](http://www.taylor-dunn.com)**