

**OPERATION
AND
MAINTENANCE
MANUAL
WITH
PARTS LIST**

MODEL: SS5-34
SERIAL NO: 77777 to 79077
MANUAL NO: MS-534-02

****IMPORTANT****

READ AND FOLLOW INSTRUCTIONS GIVEN IN SAFETY AND OPERATIONS SECTIONS, AND THOSE SECTIONS RELATED TO YOUR SERVICE AND REPAIR RESPONSIBILITIES.



TAYLOR-DUNN[®]
Commercial and Industrial Vehicles Since 1949

2114 W. Ball Rd., Anaheim, CA 92804 (714)956-4040 (FAX) (714)956-0504
Mailing Address: P.O. Box 4240, Anaheim, California 92803

- IMPORTANT INFORMATION -

This vehicle conforms to applicable portions of ANSI B56.8 {American National Standard Personnel and Burden Carriers}. This manual is designed for use by Vehicle Operators and Service Personnel alike. Throughout the manual, there are various WARNINGS, CAUTIONS, and NOTICES which must be carefully read to help reduce the possibility of personal injury. Maintenance personnel must understand that if a service procedure or method is used that is not recommended by Taylor-Dunn, it then becomes the personal responsibility of the person performing the work to first satisfy himself that neither his safety, the safety of others, or the safety of the vehicle will be endangered. ANSI B56.8 applies to only those vehicles with Serial Numbers dated after July 31, 1982.

Definitions of the three terms are as follows:

WARNING - There is a potential for injury to yourself or others.

CAUTION - There is a potential for damage to the vehicle.

NOTE - Specific information clarifying or giving the reason for a particular maintenance or service procedure.

Before operating your Taylor-Dunn vehicle, it is your responsibility to read, understand and follow the safety and operating instructions contained in this manual to help ensure your safety and comfort. If this car is to be used for rental purposes, it is your responsibility to explain to the operator about the various controls and vehicle operating characteristics. Equally important is the operators need to know the basic rules required for safe operation of the vehicle in day to day usage. Sections 5 and 6 of ANSI B56.8 have been inserted in Section B, page 3 of this manual for your specific operating guidelines.

1. Vehicle is to be operated only by qualified persons and only in designated areas.
2. Vehicle will not be started until all occupants are seated.
3. Occupants must remain seated while vehicle is in motion.
4. Arms, legs and feet must be kept inside while vehicle is in motion.
5. Slow down when making a turn.
6. Drive slowly straight up and down inclines.
7. Set parking brake before leaving vehicle.
8. Forward/Reverse lever must be in the correct position for direction of travel desired.

WARNING: FAILURE TO COMPLY WITH ABOVE INSTRUCTIONS COULD RESULT IN INJURY TO THE VEHICLE OCCUPANTS, BYSTANDERS AND TO PROPERTY.

TABLE OF CONTENTS

CONTENTS	SECTION	ILLUSTRATION
INSPECTION, SAFETY, AND INTRODUCTION	A	
OPERATING INSTRUCTIONS	B	
MAINTENANCE GUIDE CHECKLIST	D	
LUBRICATION DIAGRAM	E	Figure 1
TOUBLE SHOOTING CHECKLIST	F	
WIRING DIAGRAM	G	Figure 2,2A
PARTS ORDERING PROCEDURE	H	
RECOMMENDED SPARE PARTS LIST	I	
MAINTENANCE PROCEDURES, SERVICE AND ADJUSTMENTS,		
PARTS ILLUSTRATIONS AND LISTINGS		
FRONT AXLE STEERING AND TIRES	J1	Figure 3 or 4
DRIVE AXLE ASSEMBLY	J2	Figure 5
MECHANICAL BRAKE	J2B	Figure 5B
PRIMARY DRIVE - BELTS, PULLEYS & MOTOR MOUNTS	J2D	Figure 5D
REAR AXLES	J2H	Figure 5H
D.C. MOTOR	J2M	Figure 5M
DIFFERENTIAL	J2R	Figure 5R
MECHANICAL CONTROL LINKAGE	J4	Figure 7
SPEED CONTROL & MAIN POWER SWITCHING	J6	Figure 9
GENERAL ELECTRICAL SYSTEM	J7	Figure 10
BATTERIES AND CHARGER	J8	
BODY AND TRIM PARTS	J9	Figure 11
POWER-TRON		SUPPLEMENT

INSPECTION AND INTRODUCTION
ARRIVAL INSPECTION CHECK LIST

Visual inspection should be made to determine that the truck has remained in good condition during transit. If any damage is found, the details should be noted on the delivery receipt immediately. After delivery the truck should be most carefully checked for HIDDEN DAMAGE. Any concealed damage not noted on the delivery receipt should be reported, in writing, to the delivering carrier within 48 hours.

The following check list has been prepared to aid you during arrival and inspection of your vehicle.

- a. Open all packages and examine any accessories which may be shipped detached from vehicle.
- b. Examine wiring for visible evidence of damage. Check all connections to insure that none have loosened during transit.
- c. Check all battery connections and electrolyte level in each cell.
- d. Inspect battery charger in accordance with manufacturers installation instructions.
- e. Check tires for damage and proper inflation. Check wheel lugs to insure their being tight.
- f. If vehicle is equipped with hydraulic brakes, check hydraulic lines for evidence of damage.
- g. Check brake fluid level in master cylinder.
- h. Examine entire vehicle for damage such as dents or cracks.
- i. Check operation of controls to see that they are working freely.

Upon completion of the Visual Inspection, an operational test should be made. Refer to operating instructions Section B.

INSPECTION, SAFETY AND INTRODUCTION
SAFETY

The safe and satisfactory use of any vehicle is responsibility shared by many persons.

As the manufacturer, we feel that it is our responsibility to emphasize vehicle characteristics and make safety recommendations regarding those characteristics. That is the primary purpose of this portion of the manual.

Persons who operate this vehicle need to be aware of, and to observe, the safe driving rules established in their locality, and need also to be aware of the vehicle operating characteristics and safety recommendations of the manufacturer, to assist them in exercising the judgement necessary to prevent injury to themselves or to others.

IMPORTANT: Persons who service and maintain the vehicle need to be aware of how their activities relate to safe vehicle operation, and of potential hazards involved in the service and maintenance processes, to assist them in applying sensible judgement to those processes.

STEERING: This vehicle has a very small minimum turning radius, which is very desirable for maneuverability.

CAUTION: This characteristic, so desirable at slow speeds, requires that great care be exercised at high speeds to avoid turning so sharply that one or more wheels lose contact with the ground, or that the vehicle is cause to overturn. Be especially careful while traveling on an incline. Avoid sharp turns, even at slow speeds.

SPEED CAUTION: This vehicle is designed to attain its maximum safe operating speed on level ground. That speed can easily be exceeded when traveling down-hill. If this is allowed to occur, vehicle stability, braking performance and motor life become unpredictable. Do not exceed, under any conditions, the vehicle maximum design speed of 10 MPH.

CONTROLS: Bring the vehicle to a complete standstill before operating the forward/reverse switch to change direction of travel. Operation of this control while the vehicle is in motion can result in complete loss of power and brakes.

Do not use the accelerator to hold the vehicle at a standstill on an incline. This can cause complete power loss. Use only the brakes to hold the vehicle at rest while on a hill.

BRAKES: The brake system relies on contact of rear tires with the ground for effectiveness. As tire to ground contact is reduced, braking effect is reduced. While driving, the operator must consider terrain, speed, and steering maneuvers to prevent tires from losing contact with the ground, with consequent reduction of braking action.

INSPECTION, SAFETY AND INTRODUCTION

SAFETY
(CONT)

MAINTENANCE: Many operating characteristics relate to maintenance in ways which are not readily obvious. Those characteristics most closely related to vehicle operating safety are indicated in Sections D and E.

Also to be considered is the safety of personnel who perform service and maintenance duties. Two characteristics need special emphasis.

1. This electric vehicle does not "idle" noisily, is never "out of gear", and is set into motion whenever the battery to motor circuit is closed, intentionally or otherwise. Whenever practical, disconnect one or both battery leads to avoid unintentional starting of the motor during servicing and maintenance.
2. Batteries emit gases which can be explosive, especially while they are being charged. Personnel who are involved with servicing vehicles, or maintaining vehicles, need to be made familiar with this hazard. A detailed explanation is contained on Page 1 and 3 of Section J8.

CAUTION:

1. When performing maintenance on any part of the vehicle electrical system disconnect main battery leads, place forward/reverse switch in neutral. Remove key from keylock in dash panel.
2. Never replace a circuit fuse with one having a higher rating than the original equipment fuse. Fuses have been selected to provide full circuit protection for all operating conditions. A FUSE WILL ONLY BLOW DUE TO A SHORT-CIRCUIT. Therefore, always locate and correct the cause of short-circuit before replacing a blown fuse. Using a fuse of higher rating is an UNSAFE PRACTICE and could cause serious damage to equipment.
3. Intentional or unintentional mis-use of controls could result in an accident.

INTRODUCTION

This vehicle is designed to be driven on smooth surfaces in and around industrial plants, nurseries, institutions, motels, mobile home parks and resorts. It is not designed to be driven on the public highways. It is not designed to be driven or towed at speeds in excess of 10 MPH on level surfaces or downhill. Speeds in excess of this may result in difficulty in steering, or may damage the motor windings through over-speeding.

MODEL NUMBER

This manual covers Model SS-025-34 (2534SS) starting with Serial No. 31000.

SERIAL NO.

The serial number of your unit is stamped into the upper surface of the tubular frame member, just below the deck board. The model number and serial number are on a nameplate riveted to the kick panel. In ordering parts referring to your unit, please use these numbers. Replacement parts can be purchased directly from distributors located across the United States.

OPERATING INSTRUCTIONS

The controls on your Taylor-Dunn vehicle have been designed and located for convenience of operation and efficient performance. Before driving your vehicle for the first time, familiarize yourself with each of the controls after carefully reading the instructions contained in this manual.

STEERING - TILLER TYPE

The Steering Tiller is designed for two hand control. It is directly connected to the front wheel fork spindle. Move the tiller counterclockwise when making a left turn or clockwise when making a right turn.

STEERING - WHEEL TYPE

The Steering Wheel and Steering System is similar to automotive types. Turn the steering wheel to the right (or clockwise) for a right run and left (or counterclockwise) for a left turn.

KEY LOCK

Your vehicle is equipped with a keyed lock located on the corner of forward/reverse switch. It is designed to lock the switch in the Neutral position only. The key will remove from the lock in the locked position (Neutral) only.

BRAKE - SERVICE & PARKING - FOOT OPERATED

The brake pedal is designed and located for right foot operation. It is the pedal located to the left of accelerator pedal. It functions the same as the brake pedal in your automobile. Depressing the pedal applies the braking action. The greater the effort applied to the pedal with your foot, the greater the braking action to your vehicle. Removing your foot from the pedal allows immediate release of the braking action to your vehicle. The brake pedal pad swivels to engage a lock for parking vehicle. Applying pressure to the rear of the pedal with your heel will engage the lock and hold brake in the on position after foot is remove from pedal. To release brake from the locked position apply foot preesure to the forward part of the pedal. Lock will disengage and pedal will be free to travel.

FORWARD-REVERSE SWITCH

The forward/reverse switch handle is located to the right of the drivers seat. To place in forward position push handle downward. To place in reverse position pull the handle upward.

CAUTION: The forward/reverse switch serves the same purpose as the transmission in your automobile. Treat it with the same respect and care. DO NOT SHIFT from forward to reverse or vice-versa while the vehicle is in motion. Shifting while in motion, especially near top speed, causes great strain to your entire vehicle and will eventually cause severe damage.

Accelerator Pedal

The accelerator pedal is located to the right of the brake pedal. It is designed for right foot operation similar to your automobile. Depressing the pedal turns the power on to the motor. It also controls the amount of power delivered to the motor in 3 steps. When driving your vehicle you will be able to feel the 3 steps of power, with full power when accelerator is fully depressed and minimum power when only partially depressed. You will have the same control of power in both directions of travel. Your forward-reverse switch determines the direction of travel and your accelerator pedal controls the speed.

Horn Button

The horn button is located in steering tiller or adjacent to steering gear box. Depressing button sounds horn. Releasing button will immediately silence horn.

Light Switch

The light switch that controls headlamps and taillamps is located on the steering tiller or adjacent to steering gear box. It is labelled for On-Off positions.

Battery Charger

Refer to Section J-8 for proper instructions to operate your battery charger.

Special Accessories

Refer to the appropriate section of this manual for separate operating instructions pertaining to any special feature or accessory your vehicle may have.

OPERATING RESPONSIBILITIES
AMERICAN NATIONAL STANDARD PERSONNEL AND BURDEN CARRIERS
ANSI B 56.8-1981
SECTION 5
OPERATING RULES AND PRACTICES

501 OPERATOR QUALIFICATIONS

Only trained and authorized operators shall be permitted to operate a Personnel and Burden Carrier. Operators of Personnel and Burden Carriers shall be qualified as to visual, auditory, physical, and mental ability to safely operate the equipment according to Section 5 and all other applicable parts of this standard.

502 PERSONNEL AND BURDEN CARRIER OPERATORS' TRAINING

(a) The carrier owner, lessee, or employee of the carrier operator shall conduct an operators' training program for the carrier operators.

(b) Successful completion of the operators' training program shall be required by the owner, lessee, or employer of the carrier operator before operation of the Personnel and Burden Carrier by any operator.

(c) An effective operator's training program should center around user company's policies, operating conditions, and their Personnel and Burden Carrier by any operator.

(d) Information on operator training is available from several sources, including carrier manufacturers.

(e) The carrier owner, lessee, or employer of the carrier operator should include in the operators' training program the following:

(1) Careful selection of the operators, considering physical qualifications, job attitude and aptitude.

(2) Emphasis on safety of stock, equipment operator, and other employees.

(3) General safety rules contained in this standard and the additional specific rules determined by the carrier owner, lessee, or employer of the carrier operator in accordance with this standard, and why they were formulated.

(4) Introduction of equipment, control locations and functions, and explanation of how they work when used properly and when used improperly; and ground and floor conditions, grade, and other conditions of the environment in which the Personnel and Burden Carrier is to be operated.

(5) Operational performance tests and evaluations during, and at completion of the program

(6) Rules of the employer and any applicable labor contract governing and dealing with discipline of employees for violation of employer's rules, and including safety rules.

503 OPERATOR RESPONSIBILITY

Operators of Personnel and Burden Carriers shall abide by the following safety rules and practices in 504, 505, 506, and 507.

504 GENERAL

(a) Safeguard the pedestrians at all times. Do not drive carrier in a manner that would endanger anyone.

OPERATING RESPONSIBILITIES
ANSI B56.8-1981

504 GENERAL continued

(b) Riding on the carrier by persons other than the operator is authorized only when personnel seat(s) are provided. Do not put any part of the body outside the outer perimeter of the carrier.

(c) When a Personnel or Burden Carrier is left unattended, stop carrier, place directional controls in neutral, apply the parking brake, stop the engine or turn off power, turn off the control or ignition circuit, remove the key if provided, and block the wheels if machine is on an incline.

(d) A Personnel and Burden Carrier is considered unattended when the operator is 25 ft. (7.6 m) or more from the carrier which remains in his view, or whenever the operator leaves the carrier and it is not within his view. When the operator of a Personnel and Burden Carrier is dismounted and within 25 ft. (7.6 m) of the carrier still in his view, he still must have controls neutralized, and brakes set to prevent movement.

(e) Maintain a safe distance from the edge of ramps and platforms.

(f) Use only approved Personnel and Burden Carriers in hazardous locations.

(g) Report all accidents involving personnel, building structures, and equipment.

(h) Operators shall not add to, or modify, the Personnel or Burden Carrier.

(i) Fire aisles, access to stairways, and fire equipment shall be kept clear.

(j) Operators and personnel shall be warned of the hazards of long hair and loose clothing.

505 TRAVELING

(a) Observe all traffic regulations, including authorized plant speed limit. Under normal traffic conditions keep to the right. Maintain a safe distance, based on speed of travel, from the carrier or vehicle ahead; and keep the Personnel and Burden Carrier under control at all times.

(b) Yield the right of way to pedestrians, ambulances, fire trucks, or other carriers or vehicles in emergency situations.

(c) Do not pass another carrier or vehicle traveling in the same direction at intersections, blind spots, or at other dangerous locations.

(d) Keep a clear view of the path of travel, observe other traffic and personnel, and maintain a safe clearance.

(e) Slow down and sound the audible warning device at cross aisles and other locations where visibility is obstructed.

(f) Ascend or descend grades slowly.

(g) Use extra caution when operating on grades. Never turn on any grade, ramp, or incline; always travel straight up and down.

(h) Under all travel conditions the carrier shall be operated at a speed that will permit it to be brought to a stop in a safe manner.

(i) Make starts, stops, turns, or direction reversals in a smooth manner so as not to shift the load, overturn the carrier, or both.

(j) Do not indulge in stunt driving or horseplay.

(k) Slow down when approaching, or on, wet or slippery surfaces.

OPERATING RESPONSIBILITIES
ANSI B56.8-1981

505 TRAVELING continued

(l) Do not run carrier onto any elevator unless specifically authorized to do so. Approach elevators slowly, and then enter squarely after the elevator car is properly leveled. Once on the elevator, neutralize the controls, shut off power, and set brakes. It is advisable that all other personnel leave the elevator before a carrier is allowed to enter or leave.

(m) Avoid running over loose objects on the roadway surface.

(n) Prior to negotiating turns, reduce speed to a safe level, turning hand steering wheel or tiller in a smooth, sweeping motion.

506 LOADING

(a) Handle only stable or safely arranged loads. When handling off-center loads which cannot be centered, operate with extra caution.

(b) Handle only loads within the capacity of the Personnel and Burden Carrier as specified on the nameplate.

(c) Handle loads exceeding the dimensions used to establish carrier capacity with extra caution. Stability and maneuverability may be adversely affected.

507 OPERATOR CARE OF MACHINE

(a) At the beginning of each shift during which the Personnel and Burden Carrier will be used, the operator shall check the carrier condition and inspect the tires, warning devices, lights, battery, controller, brakes, and steering mechanism. If the carrier is found to be in need of repair, or in any way unsafe, or contributes to an unsafe condition, the matter shall be reported immediately to the designated authority, and the carrier shall not be operated until it has been restored to safe operating condition.

(b) If, during operating the carrier becomes unsafe in any way, the matter shall be reported immediately to the designated authority, and carrier shall not be operated until it has been restored to safe operating condition.

(c) Do not make repairs or adjustments unless specifically authorized to do so.

(d) The engine shall be stopped and the operator shall leave the carrier while refueling.

(e) Spillage of oil or fuel shall be carefully and completely absorbed or evaporated and fuel tank cap replaced before starting engine.

(f) Do not operate a carrier with a leak in the fuel system or battery.

(g) Do not use open flames for checking electrolyte level in storage batteries or liquid level in fuel tanks.

SECTION 6
MAINTENANCE PRACTICES

601 INTRODUCTION

Personnel and Burden Carriers may become hazardous if maintenance is neglected. Therefore, maintenance facilities, trained personnel, and procedures shall be provided.

MAINTENANCE PRACTICES
ANSI B56.8-1981

602 MAINTENANCE PROCEDURES

(a) Maintenance and inspection of all Personnel and Burden Carriers shall be performed in conformance with the manufacturer's recommendations and the following practices.

(b) A scheduled preventive maintenance, lubrication, and inspection system shall be followed.

(c) Only qualified and authorized personnel shall be permitted to maintain, repair, adjust, and inspect Personnel and Burden Carriers.

(d) Before leaving the Personnel and Burden Carrier, stop carrier, place directional controls in neutral, apply the parking brake, stop the engine or turn off power, turn off the control or ignition circuit, and block the wheels if carrier is on an incline.

(e) Before undertaking maintenance or repair on carrier, raise drive wheels free of floor or disconnect battery, and use chocks or other positive carrier positioning devices.

(f) Block chassis before working under it.

(g) Before disconnecting any part of the engine fuel system of a gasoline or diesel powered carrier with gravity feed fuel systems, be sure shutoff valve is closed, and run engine until fuel system is depleted and engine stops running.

(h) Before disconnecting any part of the engine fuel system of LP gas powered carriers, close the LP gas cylinder valve and run the engine until fuel in the system is depleted and the engine stops running.

(i) Operation to check performance of the Personnel and Burden Carrier shall be conducted in an authorized area where safe clearance exists.

(j) Before starting to operate the carrier:

- 1) Have operator in the operating position.
- 2) Depress clutch (or brake pedal on automatic transmission and electric carriers).
- 3) Place directional controls in neutral.
- 4) Start engine or switch electric carrier to "on" position.
- 5) Check functioning of directional speed controls, steering, warning devices steering, warning devices, and brakes.

(k) Avoid fire hazards and have fire protection equipment present in the work area. Do not use an open flame to check level or leakage of fuel, electrolyte, or coolant. Do not use open pans of fuel or flammable cleaning fluids for cleaning parts.

(l) Properly ventilate work area.

(m) Handle LP gas cylinders with care. Physical damage, such as dents, scrapes, or gauges, may dangerously weaken the tank and make it unsafe for use.

(n) Brakes, steering mechanisms, control mechanisms, warning devices, lights, governors, guards, and safety devices shall be inspected regularly and maintained in a safe operating condition.

(o) Special Personnel and Burden Carriers or devices designed and approved for hazardous area operation shall be inspected to ensure that maintenance preserves the original approved safe operating features.

(p) Fuel systems shall be checked for leaks and condition of parts. Action shall be taken to prevent the use of the carrier until the leak has been corrected.

MAINTENANCE PRACTICES
ANSI B56.8-1981

602 MAINTENANCE PROCEDURES continued

(q) The Personnel and Burden Carrier manufacturer's capacity, operation and maintenance instruction plates, tags, or decals shall be maintained in legible condition.

(r) Batteries, motors, controllers, limit switches, protective devices, electrical conductors, and connections shall be inspected and maintained in conformance with good practice.

(s) Carriers shall be kept in a clean condition to minimize fire hazards and facilitate detection of loose or defective parts.

(t) Modifications and additions which affect capacity and safe machine operation shall not be performed by the customer or user without manufacturer's prior written authorization; where authorized modifications have been made, the user shall ensure that capacity, operation, warning and maintenance instruction plates, tags, or decals are changed accordingly.

(u) Care shall be taken to assure that all replacement parts are interchangeable with the original parts and of a quality at least equal to that provided in the original equipment.

VEHICLE OWNER AND OPERATOR'S GUIDELINES

OPERATING YOUR VEHICLE

To put your vehicle into operation, unlock forward/reverse switch by turning keyed lock counter clockwise. Select direction you wish to travel by moving handle of forward/reverse switch into position. Release parking brake, slowly depress accelerator pedal until vehicle is moving at the desired speed. Steer vehicle as required utilizing the foot brake and accelerator to control your speed as desired.

CAUTION: DO NOT "hold vehicle at a standstill on a hill or incline using accelerator only. Continued "stalled" condition as described will damage motor and electrical controls. Use either your foot brake or hand brake to hold the vehicle on a hill safely.

CAUTION: When you leave your vehicle, it is best to always place forward/reverse switch in neutral position. Set parking brake to prevent vehicle from rolling free, and lock and remove key.

Drive safely and enjoy your Taylor-Dunn vehicle.

MAINTENANCE GUIDE CHECKLIST

This checklist is provided for your convenience as a guide for servicing your vehicle. If followed you will enjoy a good running and trouble free unit. It has been set up for average normal use. More frequent service is recommended for extreme or heavy usage. If desired your Taylor-Dunn dealer will gladly perform these services for you as he has expert servicemen in the field for this purpose. Do not hesitate to call your Service Manager if any questions arise.

CAUTION: When performing maintenance on any part of the electrical system, disconnect main battery leads, place Forward/Reverse Switch in Neutral, turn key to OFF position and remove from switch. Set Parking Brake.

MAINTENANCE SERVICE	REFER SECTION	EVERY WEEK	EVERY MONTH	EVERY 3 MONTHS	EVERY YEAR
Check & record Sp. gravity & water level of each cell. Fill, as necessary, using distilled water. (See Chart in Section J8).	J8	X			
* Examine battery terminal connection. Clean and tighten as necessary, <u>but not</u> while batteries are being charged.	J8	X			
* Clean off all dirt & grease on and between power bars with a rag, piece of wood or plastic, steam clean or with an <u>Electrically Non-Conductive object</u> . Apply small quantity of T-D Grease, Part No. 94-421-00, or quality hi-temp grease (500° Min. Drop Pt.) to sliding contact area with <u>Electrically Non-Conductive Applicator</u> .	J6 & E	X			
* Check Speed Control Rotor adjustment	J6	X			
* Check Tire pressure	J1	X			
Adjust belt tension	J2		X		
* Lubricate all zerk fittings	E		X		
* Lubricate linkage pivot points and suspension points with all purpose engine oil.	E		X		
Wash off batteries with water, (Use soda if necessary).	J8		X		
* Check all wire connections. Be sure they are all clean and tight, <u>but not</u> while batteries are being charged.			X		
* Items related to safety recommendations.					

MAINTENANCE GUIDE CHECKLIST

MAINTENANCE SERVICE	REFER SECTION	EVERY WEEK	EVERY MONTH	EVERY 3 MONTHS	EVERY YEAR
1. *Check brake lining for wear Adjust or replace as necessary.	J2		X		
Check drive axle oil level. (Refer to lubrication diagram).	J2 & E		X		
* Check and adjust front wheel bearings and fork spindle bearings.	J1			X	
Check motor brushes. Blow out carbon dust. (Replace if necessary).	J2			X	
* Check and adjust brake linkage	J2			X	
Drain differential and refill with SAE 30 oil (Refer to lubrication diagram).	J2 & E				X
Repack front wheel bearings and fork spindle bearings (Use wheel bearing grease).	J1 & E				X
* Items related to safety recommendations.					
1. CAUTION: <u>Never bend</u> the brake band anchor bolt. Any bending of the bolt may result in <u>unexpected failure</u> of the bolt and <u>complete loss</u> of Drive Line braking Action.					

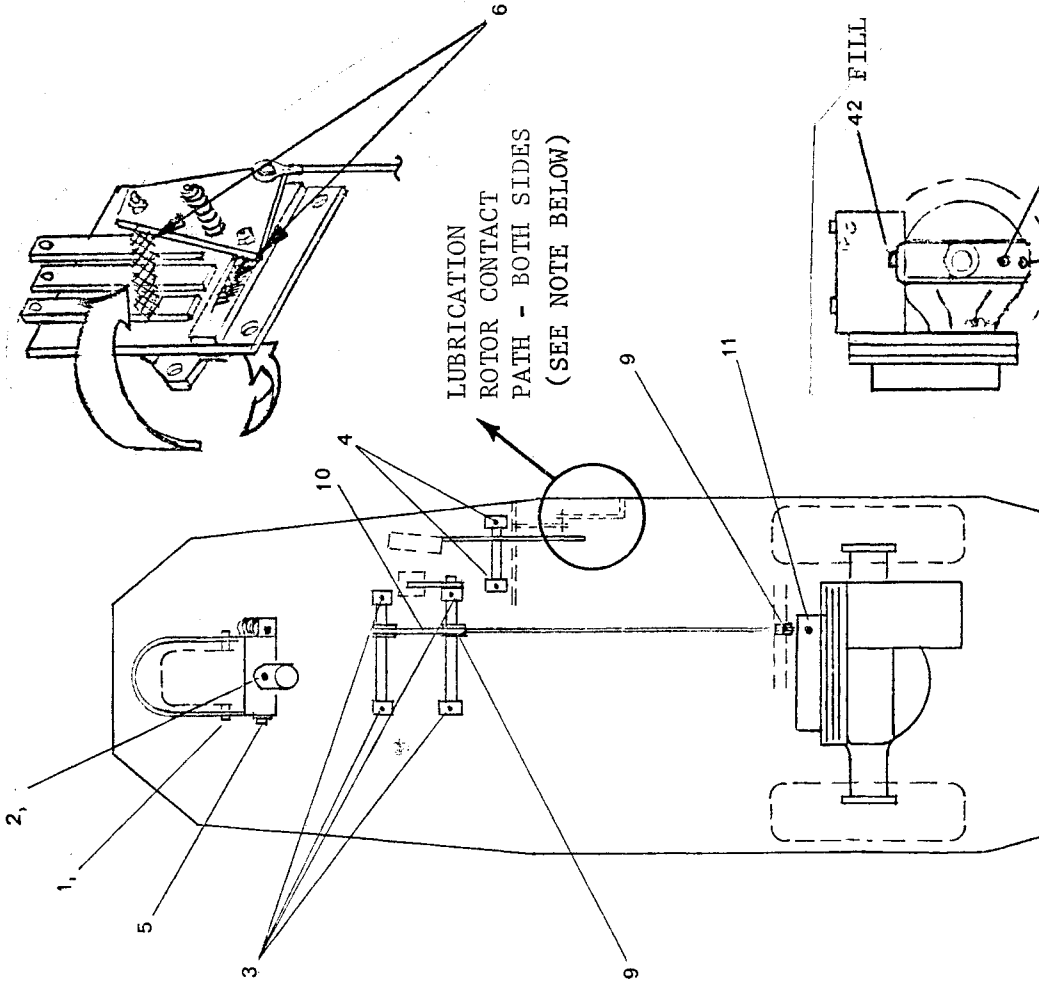

LUBRICATION ROTOR CONTACT PATH - BOTH SIDES (SEE NOTE BELOW)

NOTE: LUBRICATE WEEKLY. REFER TO SECTION D, PAGE 1 AND SECT. J6 FOR SWITCH CLEANING & LUBRICATION DETAILS.

SIDE VIEW

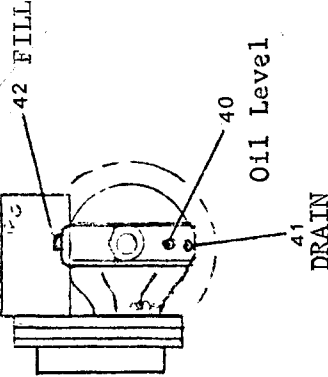

SECTION E PAGE 1

SECTION E PAGE 1		SECTION E PAGE 1	
NO.	DESCRIPTION	LENGTH	QUAN.
TOL. FRAC.	DEC.	REVISED DATE	REVISION
SCALE	NONE	LUBRICATION DIAGRAM MODEL 2534SS	
DRAWN BY	EDE	TAYLOR DUNN MFG. CO. 2114 West Ball Rd. Anaheim, Calif.	
DATE	7-17-81	*Items related to Safety Recommendations	

	NO. OF PLACES	FREQUENCY
A. PRESSURE GUN GREASE		
* 1. Front Wheel Bearings	1	Month
2. Fork Collar Bearings	1	Month
* 3. Brake Linkage Pivot Points	4	1 Month
* 4. Accelerator Linkage Pivot Points	2	1 Month
5. Front Fork	2	1 Month
B. T-D GREASE 94-421-00		
* 6. Master Control Switch	2	1 Week
NOTE: Apply lub with Electrically Non-Conductive Applicator. (See Maint. Guide Checklist).		
C. ALL PURPOSE ENGINE OIL		
* 9. Clevis Pins (Brake Cable Pivot Points)	2	1 Month
* 10. Brake Pedal Connecting Link	2	3 Months
* 11. Brake Arm Pivot Bar	1	3 Months
D. SAE 30 OIL - AXLE & DIFFERENTIAL		
40. Level Check	1	1 Month
Change Oil		
a. Remove Drain Plug 41, Level Plug 40 and Fill Plug 42		1 Year
b. Drain Oil, Replace 41		
c. Add Oil by 42 to level of 40		
d. Replace 42 & 40		

TROUBLE SHOOTING PROCEDURES

<u>SYMPTOM</u>	<u>PROBABLE CAUSE</u>	<u>CORRECTIVE ACTION</u>
1. <u>Steering:</u>		
(a) Pull in one direction	1. Check for bent fork	Replace or straighten
(b) Hard Steering	1. Bad or frozen bearing in fork spindle collar 2. Low tire pressure	Replace Inflate to recommended pressure
(c) Sloppy or loose steering	1. Loose spindle bearing 2. Loose wheel bearing	Adjust Adjust
2. <u>Brakes:</u>		
(a) Soft brakes	1. Check for worn lining 2. Alignment of brake shoes 3. Oil on brake lining 4. Dirt on brake lining 5. Bind in linkage 6. Weak spring 7. Air in hydraulic brake lines 8. Bad seals in brake cylinders	Adjust or replace when 1/16 or less of lining left Realign Find oil source and correct, wash brake band Clean Loosen or realign Replace Bleed brakes Replace
(b) No Brakes	1. Broken shoe 2. Broken connection in linkage 3. Broken Axle 4. Break in hydraulic line 5. Seal failure in brake cylinder	Replace Replace Replace Repair Replace
3. <u>Drive Axle:</u>		
(a) No power	1. Discharged batteries 2. Check rheostat for contact 3. Check motor brushes for contact 4. Poor contact on forward-reverse switch 5. Check for loose wire 6. Check continuity through motor	Recharge or replace Adjust or replace bars Clean or replace Repair or replace Tighten or replace Repair or replace

<u>SYMPTOM</u>	<u>PROBABLE CAUSE</u>	<u>CORRECTIVE ACTION</u>
(c) Jerky starting	1. Resistor coil burned out 2. Resistor shorted together 3. Dirt between power bars causing shorts	Replace Spread apart Clean
(d) Takes off in forward or reverse without accelerator depressed.	1. Speed rotor path not lubricated. 2. Speed rotor fails to return to neutral. 3. Broken accelerator return spring. 4. Dirt shorting out neutral bar. 5. Short in wiring circuit.	Lubricate Adjust linkage Replace spring Clean, readjust, or replace bars. Correct
(e) Lack of power or slow operation.	1. Dragging brake. 2. Tight front wheel bearings. 3. Contact button not engaging high speed bar. 4. Loose connection in wiring 5. Partially burned out motor. 6. Weak batteries. 7. Bind or drag on differential	Readjust Readjust Adjust linkage or Tighten Repair or replace Recharge or replace (see g & h) Repair
(f) Thump or grinding noise in drive axle.	1. Motor bearing. 2. Loose motor on base. 3. Defective bearing differential 4. Defective gears in differential.	Replace Tighten & adjust Replace Replace
(g) Two right batteries discharged, two left batteries o.k.	1. Short between 1st & 2nd power bar. 2. Short circuit in lights or accessories. 3. Lights or accessories, left on unintentionally. 4. Stop light switch or circuit malfunction.	Repair or replace Repair Recharge batteries Repair
(g) Two left batteries discharged, two right batteries o.k.	1. Continued operation in 1st speed 2. Speed control rotor fails to return to neutral.	Correct driving habits. Refer to d1,d2,d3, & d4

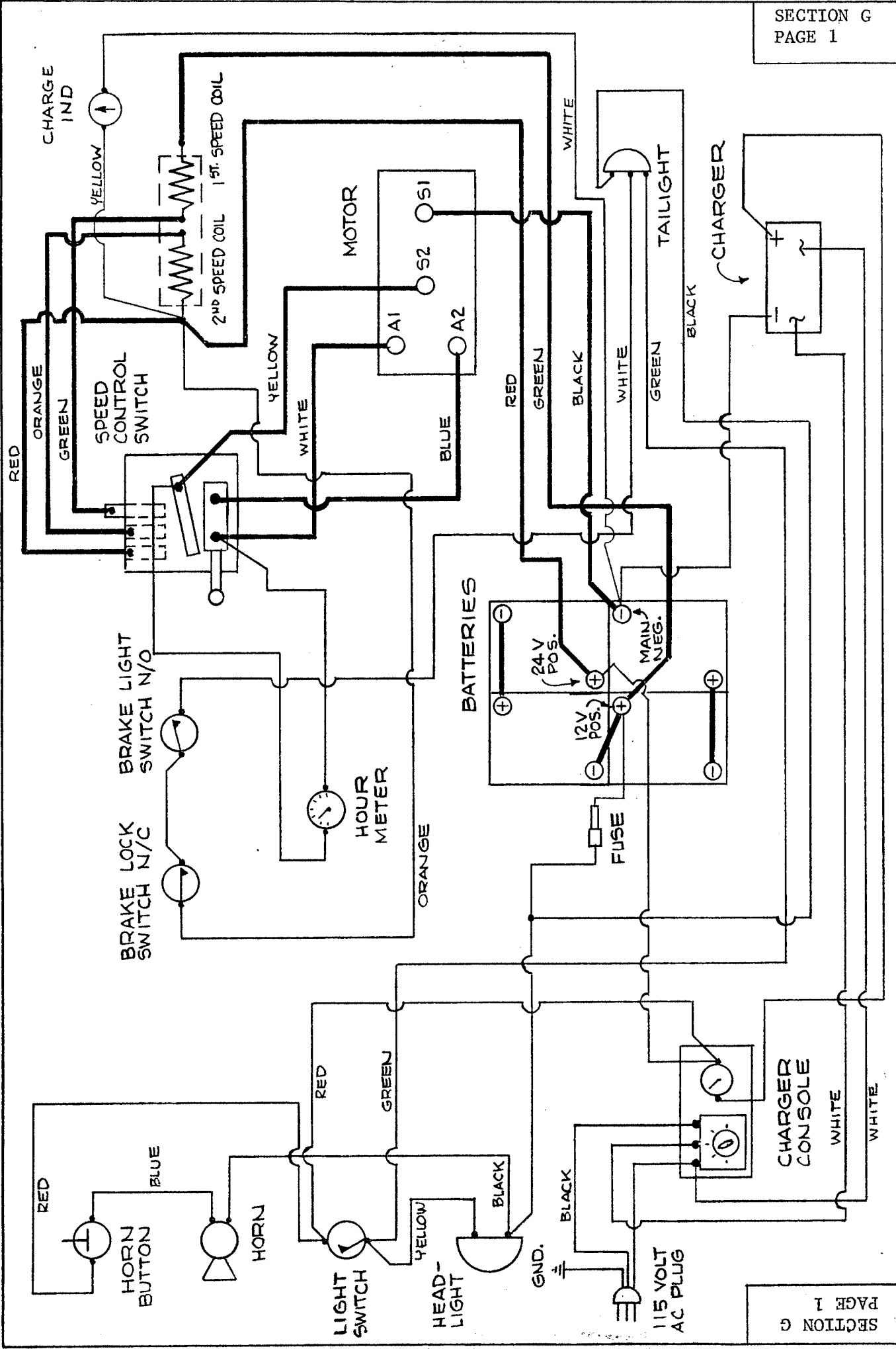

SECTION G
PAGE 1

NO.	DESCRIPTION	LENGTH	QUAN.	REVISED DATE	REVISION
TOL. FRAC. ±	DEC. ±				
SCALE	NONE				
DRAWN BY	EDB				
DATE	8-18-80				

FIGURE 2
SECTION G
WIRING DIAGRAM - POWER,
ACCESSORY & CHARGE CKTS.

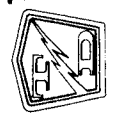

TAYLOR DUNN MFG. CO.
2114 West Ball Rd.
Anaheim, Calif.

NO.	DESCRIPTION
TOL. FRAC. †	DEC. †
SCALE	NONE
DRAWN BY	EDB

FIGURE 2A
SECTION G

2534 S5
WIRING DIAGRAM - POWER,
ACCESSORY & LIFT-OUT BOX

TAYLOR DUNN MFG. CO
2114 West Dall Rd.
Anaheim, Calif.

LENGTH	QUAN.	REVISED DATE	REVISION
--------	-------	--------------	----------

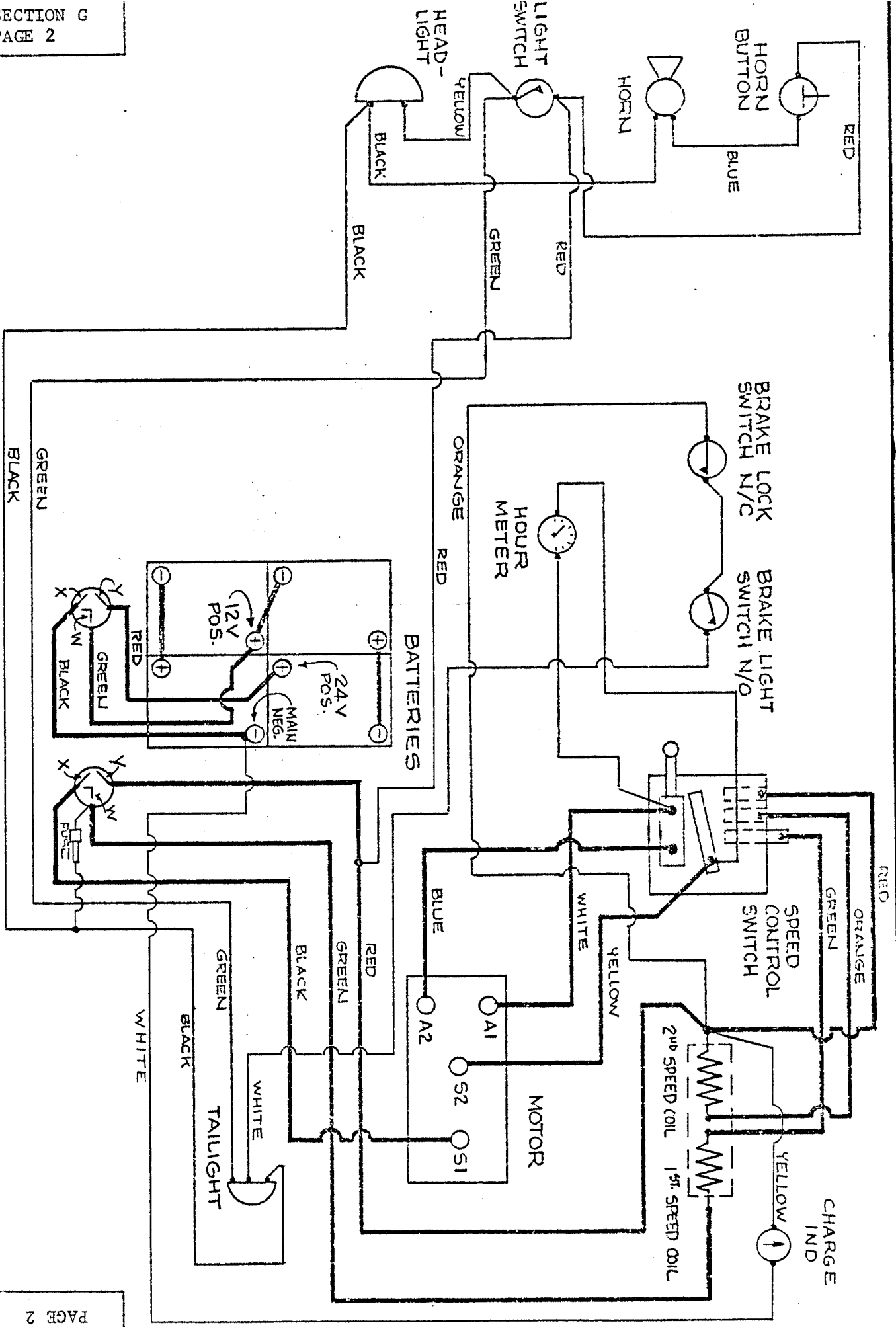

PARTS ORDERING PROCEDURE

Parts may be purchased from your local authorized Taylor-Dunn Dealer. When ordering parts, be sure to specify the complete model no. and serial no. of the unit. Also specify the full Taylor-Dunn part no., description of part, and quantity required. You will find a complete listing of part numbers and descriptions in the following pages of this manual. When ordering parts for the drive motor, it is necessary to include complete name plate data with the order. Be sure to give complete shipping and billing address on all orders. Example:

- 1 - Part #86-501-98 ball joint (left hand thread)
- 1 - Part #70-124-00 (set of 4) motor brushes for Baldor Motor, 3½ H.P., 36 Volt, Specification Number 28-1408-11704

Parts ordered under warranty must be placed with your authorized Taylor-Dunn Dealer. Be sure to include original invoice number, date of shipment of vehicle, and vehicle serial number.

Note: On contracts with National Federal Government Agencies, Defense General Supply Agency and United States Post Office Department, orders for all warranty parts must be placed directly with the Taylor-Dunn Factory in Anaheim, California.

TAYLOR-DUNN MANUFACTURING CO.
2114 West Ball Road
Anaheim, California 92804

Telephone: 714-956-4040
Telex: 65-5393

SUGGESTED SPARE PARTS LIST

FIG. I.D. NO.	T-D PART NO.	DESCRIPTION	QTY. OF 1-20 UNITS
------------------	-----------------	-------------	-----------------------

REFER TO FIGURE NO. 3 FRONT AXLE, FORK & TILLER

3-10	97-100-00	Woodruff Key, 3/16	1
3-11	87-071-00	Grease Fitting, 3/16 Drive	3
3-15	45-308-00	Grease Seal	1
3-16	12-120-00	Wheel Hub - 3/4" Tapered Roller Bearings (Five Studs on 4-1/2" Bolt Circle)	0 or 1
3-17	80-015-00	Bearing, Tapered Roller 3/4"	2
3-19	87-050-00	Grease Fitting 90°, 1/4-28	1
3-21	97-236-00	Lug Nut 1/2" N.F.	5
3-27	13-576-00	Tire, Wheel & 4" Hub with 400 x 8, 4 Ply Tubeless Super Rib Tire & 3/4" Tapered Roller Bearings.	1
3-30	13-989-00	Valve Stem (For Tubeless Tires)	3

FOR GEARED STEERING ONLY - REFER TO FIGURE 4A

4A-42	97-100-00	Woodruff Key -3/16"	2
4A-44	80-706-00	O-Ring 3/4" O.D.	1
4A-45	31-255-00	Stem Pinion - 7 Tooth	1
4A-49	45-004-00	Gasket (4 x 6 O.D.)	2
4A-50	45-003-00	Gasket (4 x 4-1/2 O.D.)	1
4A-51	32-202-00	Bushing, Bronze - 1/2" I.D. x 5/8" O.D.	1
4A-52	80-400-00	Ball Bearing - 3/4" I.D.	2
4A-53	32-203-00	Bushing, Bronze - 3/4" I.D. x 7/8" O.D. x 1/2" Long	1

REFER TO FIGURE NO. 5B MECHANICAL BRAKE

5B-2	41-660-00	Brake Band for Drive Shaft Brake	1
5B-4	88-100-25	3/8 N.C. x 4-1/2 Hex Head Cap Screw	1

REFER TO FIGURE NO. 5D BELT DRIVE

5D-3	30-601-00	Belt "AX-33" for 8" Pulley	0 or 2
5D-3	30-613-00	Belt "AX-38" for 11" Pulley	0 or 2
5D-7	45-339-00	Pinion Oil Seal, 3" O.D.	0 or 1
5D-7	45-340-00	Pinion Oil Seal, 4-1/8" O.D.	0 or 1
5D-8	97-100-00	3/16 Woodruff Key	1

REFER TO FIGURE NO. 5H REAR AXLE & DIFFERENTIAL HOUSING

5H-10	41-997-00	Level Drain or Fill Plug	2
-------	-----------	--------------------------	---

SUGGESTED SPARE PARTS LIST

FIG. I.D. NO.	T-D PART NO.	DESCRIPTION	QTY. OF 1-20 UNITS
<u>REFER TO FIGURE NO. 5M D.C. MOTORS</u>			
----	-----	Spare motor for Every 5 Vehicles	-
----	-----	Motor Brushes, One Set (Two or Four/Set)	-
----	-----	Brush Carrier Complete with Brushes if applicable	-
<u>REFER TO FIGURE NO. 7 - MECHANICAL CONTROL LINKAGE</u>			
7-5	96-813-00	Brake Cable Assembly 28-1/4 to 31-1/4 Length	1
7-7	86-503-98	Rod End, Spherical Bearing - Left Hand Thread	1
7-9	97-211-00	Nut, 1/4 N.F. - Left Hand Thread	2
7-15	95-771-00	Clevis Pin, 3/8 x 3/4 Face to Hole	1
7-16	88-517-11	Cotter Pin, 3/32 x 1	4
7-17	85-295-00	Spring Extension 9/16 O.D. x 4-7/8	2
7-21	96-772-00	Clevis Pin 3/8 x 1 Face to Hole	3
<u>REFER TO FIGURE NO. 9 - MASTER CONTROL SWITCH</u>			
9-1	61-844-52	Power Bar - 3 Hole	1
9-2	61-844-51	Power Bar - 2 Hole	2
9-3	61-831-00	Power Bar	2
9-4	61-835-12	Neutral Bar	1
9-5	61-842-51	Neutral Board Forward/Reverse Switch	1
9-6	61-844-53	Rotor Board Forward/Reverse Switch	1
9-9	61-831-52	Power Bar - Steel	1
9-10	71-030-58	Contact Button	5
9-11	85-033-00	Spring 7/16 O.D. x 1-1/2 Long	1
9-12	85-034-00	Spring 7/16 O.D. x 2 Long	1
9-13	96-340-00	Pivot Stud (Double End)	1
9-26	61-841-00	Handle, Forward/Reverse Switch (Cad. Plated)	1
9-40	78-225-11	Coil Board & Resistor Coil Assembly	1
9-44	86-503-99	Rod End. Spherical Bearing Right Hand Thread	1
9-45	97-170-00	Washer, Insulated 3/4" O.D.	2
9-46	32-212-50	Plastic Bushing 1/4 x 1/4	2
9-47	61-846-51	Stabilizer Button, Forward/Reverse Switch	1
9-49	97-169-00	Washer, Nylatron, 3/8 I.D.	1
9-50	98-616-00	Insulator	1

MAINTENANCE PROCEDURES
FRONT AXLE, FORK, STEERING AND TIRES
REFER TO FIGURE 3

Your front wheel assembly consists of a ruggedly designed fork mounted with 2 Timken Roller Bearings. The front wheel is mounted on a 3/4" axle and turns on 2 Timken Roller Bearings. Two heavy coil springs and an automotive type shock absorber produce a comfortable ride. With proper care, these parts should give long service.

If by chance the front wheel should be submerged for any length of time in mud or water, it is recommended that you remove, wash & clean the axle assembly. Clean all parts, especially bearings, in a suitable cleaning solvent, re-assemble and repack with wheel bearing grease. Follow the procedures outlined in the service and adjustment section J1 of this manual.

The normal life of the shock absorber unit is 2 years, based on average use of vehicle.

The steering worm gear box and steering linkage is similar to those used on autos. It requires very little attention. Refer to Section J1A for disassemble and reassemble procedures Steering Worm Assembly. Refer to maintenance guide and lubrication diagrams (Section D & E) for normal care of your front wheel & steering assembly.

If service and adjustments are required, refer to appropriate section of this manual.

Tire Care:

Tire pressure is governed by how you want your vehicle to ride and the terrain to which it is most commonly used upon.

Slightly lower pressure will assist traction on soft terrain without undue wear.

The chart listed below will assist you to determine the correct tire pressure for your needs.

TIRE INFLATION CHART					
TIRE SIZE	TYPE	TIRE LOAD RATING		MAXIMUM (COLD) INFLATION P.S.I.	MAXIMUM LOAD POUNDS
		LOAD RANGE	EQUIVALENT PLY RATING		
4.80-8/400-8	HIGHWAY TREAD	A	2	35	665
4.80-8/400-8	HIGHWAY TREAD	B	4	70	1000
4.80-8/400-8	STEELGUARD	C	6	100	1230
5.70-8/500-8	HIGHWAY TREAD	B	4	55	1170
5.70-8/500-8	HIGHWAY TREAD	C	6	85	1505
5.70-8/500-8	STEELGUARD	D	8	100	1655
16 x 6.50 x 8	TERRA TIRE	B	4	45	810
18 x 8.50 x 8	TERRA TIRE	B	4	40	1080
18 x 9.50 x 8	TERRA TIRE	B	4	36	1315
18 x 9.50 x 8	TERRA TIRE	C	6	42	1660

THE INFLATION AND LOAD RATINGS MOLDED ON HIGHWAY TREAD TIRES, PER FEDERAL STANDARD FMVSS-119, ARE FOR MAXIMUM HIGHWAY SPEEDS AND DO NOT APPLY TO THIS LOW SPEED VEHICLE.
- TAYLOR-DUNN MANUFACTURING CO. -

CAUTION: Do not over-inflate tires as this will promote increased wear. Under inflation especially on hard surfaces also promotes undue wear and should be avoided.

SERVICE AND ADJUSTMENT
FRONT AXLE, FORK, STEERING AND TIRES
REFER TO FIGURE NO. 3

Adjustment of Wheel Bearings

1. Adjust wheel bearings by holding 1 axle nut and tightening the other until drag is felt on wheel. Then back off nut approximately 1/4 turn. Wheel should turn free but not have excess play in bearings.

Removal of Wheel & Axle Assembly

1. Remove 1 axle nut by holding nut on one end of axle and unscrewing nut on opposite end.
2. Slide axle from fork & wheel, being careful to catch spacers and wheel as they come free.
3. Wheel bearings may be flushed, claned and repacked without removing from hub, unless severely damaged or embedded with foreign material.
4. To remove wheel bearings and seals:
 - A. Pull seals from hub.
 - B. Remove taper roller bearings.
 - C. If necessary, press bearing races from hub with suitable press or with flat punch by hitting back and forth one side to other.

Re-Assembly of Wheel & Axle

1. Press bearing races into hub with suitable press, taking care that they are seated against stops within the hub.
2. Generously lubricate wheel bearings with wheel bearing grease and insert into bearing races.
3. Press or tap seals into place. (Proper position is when face of seal is flush with end of hub). Note: It is recommended that new seals be installed whenever bearings are removed from wheel hub, or whenever seals are worn or damaged. Worn or damaged seals allow dirt and foreign matter to enter wheel bearings, shortening bearing life.
4. Install wheel & hub assembly into fork by starting axle through one side of fork, inserting 1 spacer then sliding axle through wheel bearings. Insert other spacer and slide axle through remainder of fork assembly.
5. Install locknut.
6. Adjust wheel bearings as outlined above.
7. Wheel hub has 1 zerk fitting for grease lubrication.

Adjustment of Fork Spindle Bearings

1. Adjust by tightening nut until drag is felt on spindle bearings. Loosen about 1/4 turn or until spindle rotates free but does not have any play in bearings. Note: Any excessive play in spindle bearing can lead to failure due to shock effect when vehicle encounters bumps or uneven terrain.

Removal of Fork From Vehicle

1. Loosen tiller clamp and remove tiller from fork spindle. It may be necessary to work tiller loose from spindle by rocking back and forth while pulling upward until tiller is free of shaft.

NOTE: On models equipped with steering gear box, disassemble gear box as outlined on page 3 of this section.

2. Remove woodruff key and remove bearing lock nut. On earlier models it will be necessary to remove dust cap to gain access to spindle bearing locknut.
3. Raise vehicle on suitable hoist and remove fork assembly from bearing housing. Observe the location of all spacers etc., and if necessary note their location for proper replacement when reassembling the fork in vehicle.
4. Remove bearings and dust seals.
5. A puller is required to remove bearing races from housing.

Re-Assembly of Fork and Spindle

1. Bearing races may be pressed into position by using a 1/2" x 6" bolt. Place a disc or bar of suitable size over bolt then one bearing race, pass this assembly through housing. Place other bearing race, a suitable disc or bar and then the nut. Tightening the nut and bolt will draw the two bearing races into position without damage.
2. Generously pack bearings with wheel bearing grease. Assemble one dust seal and bearing in lower part of housing. Refer to Figure 3 for proper location. Slide fork spindle through housing and insert upper bearing spacers and washer.
3. Install spindle nut.
4. Adjust fork spindle bearings as previously outlined.
5. Replace dust cap on fork spindle housing. (Early models).
6. Replace bearing seal if it has been removed from bearing housing. (Late Models - Tiller Only).
7. Install woodruff key.
8. Install tiller and tighten tiller clamp securely. On models equipped with steering gear box, re-assemble box as outlined on page 4 of this section.

Dis-Assembly of Steering Gear Box

NOTE: It is not necessary to remove steering wheel from shaft unless service work is to be performed on the bearings or shaft assembly. If steering wheel is not to be removed then start with Step 2 below.

1. Remove wheel lock nut and with suitable puller remove steering wheel.
2. Remove 6 bolts holding box together.
3. Set horn button and light switch bracket aside.
4. Place sufficient rags or waste around box before removing cover to help catch the grease which has been packed inside.
5. Remove cover and gasket and set aside.
6. Scoop out as much grease as possible and then remove center of box and lower gasket.
7. Remove countershaft gear and pinion.
8. Remove fork spindle gear.

9. It will only be necessary to remove bottom gear box plate to replace bronze bushing or lower gasket. To do so remove 3 bolts and lift plate from spindle housing flange.

REPLACEMENT OF STEERING SHAFT BEARINGS

1. Remove steering shaft from steering column by removing steering wheel and top of steering gear box as previously outlined in steps 1 thru 5.
2. Slide steering shaft from assembly. Take care to note spacer location and when reassembling to return spacers to their original location.
3. Pull bearing from it's seat in the end of the steering column.
4. Clean all parts thoroughly.
5. Tap or press in new bearings seating the flange against the housing.
6. Re-assemble all parts in the reverse order to which they were removed, taking care to align steering wheel with fork.
7. Adjust shaft end play by adding or removing shims.

RE-ASSEMBLY OF STEERING GEAR BOX.

1. Bolt bottom gear box plate to spindle housing flange.
2. Install woodruff key in fork spindle shaft.
3. Install fork spindle gear (hub down).
4. Install countershaft gear and pinion.
5. Install lower gasket, center section of box and upper gasket.
6. Place cover assembly in position. Align front wheel in forward position with steering wheel. It may be necessary to remesh steering shaft gear with counter shaft gear to allow steering wheel to align with fork when in forward position.
7. Replace 6 bolts, horn and light switch bracket and tighten evenly.
8. Fill steering gear box with lubricant through zerk fitting. Note that steering gear box and fork spindle bearing housing are coupled together forming one continuous assembly. Lubricating one section will lubricate the adjoining section.

FRONT STEERING & FORKREFER TO FIGURE NO. 3

FIG. I.D. NO.	T-D PART NO.	DESCRIPTION	QTY. REQ.
3-1	97-230-00	Nut, 1" - Full Fiber Insert	1
3-2	45-307-00	Grease Seal	2
3-3	16-409-00	Spacer, .250 Thick - 1" I.D. x 1-1/2 O.D.	1
3-4	80-011-00	Bearing - Tapered Roller 1-1/4	2
3-5	80-102-00	Bearing Race for 1-1/4 Tapered Bearing	2
3-6	87-074-00	Grease Fitting, 1/4-28 Straight	1
3-8	19-101-11	Steering Loop Tiller	1
3-9	14-079-10	Front Fork (Less Springs)	1
3-10	97-100-00	Woodruff Key, 3/16	1
3-11	87-071-00	Grease Fitting 3/16 Drive	2
3-12	88-100-13	Hex Head Cap Screw, 3/8 N.C. x 1-1/4	2
3-13	85-141-00	Spring Clip	2
3-14	85-140-00	Spring-Compression, 2-7/16 x 6-1/4" Long (.362 Dia. Wire)	1
3-15	45-308-00	Oil Seal for Wheel with 3/4" Bearing	2
3-16	12-120-00	Wheel Hub - 3/4" Tapered Roller Bearings (Five Studs on 4-1/2" Circle) Not used with Wheel 13-001-00	1
3-17	80-015-00	Bearing, Tapered Roller 3/4"	2
3-18	80-105-00	Bearing Race for 3/4" Tapered Bearing	2
3-19	87-050-00	Grease Fitting 90 Degrees, 1/4-28	1
3-20	96-329-00	Bolt - Wheel Lug, Dico Wheel Hub, 1/2 N.F.	5
3-21	97-236-00	Lug Nut 1/2 (Tapered)	5
3-22	15-010-00	Front Axle 3/4 Dia. x 9-1/4" Long	1
3-23	16-207-00	Wheel Spacer 3/4 I.D. x 1/2 Thick	4
3-24	88-229-81	Lock Nut, 3/4" N.C.	2
3-25	88-108-62	Lock Washer, 3/8	2
3-26	88-149-80	Nut, 1/2" N.C.	1
3-27	13-576-10 (1982 UP)	Tire, Wheel and 4" Hub with 400 x 8, 4 Ply Tubeless Super Rib Tire & 3/4" Tapered Roller Bearings.	1
3-27	13-595-00	Tire, Tube, Wheel & 4" Hub with 16 x 6.50 x 8, 4 Ply Tire	1
3-28	13-001-00	Wheel and 4" Hub for 4.80 x 8 Tubeless Tire with 3/4" Tapered Roller Bearings. (Also used for 16 x 6.50 x 8 Tire)	1

FIG. I.D. NO.	T-D PART NO.	DESCRIPTION	QTY. REC
3-29	10-075-00	Tire, 4.80 x 8, 4 Ply, Super Rib, Tubeless	3
3-29	10-078-00	Tire, 4.80 x 8, 6 Ply, Steelguard, Tube Type	3
3-29	10-089-00	Tire, 16 x 6.50 x 8, 4 Ply, Terra Tire, Traction Tubeless	3
3-30	11-030-00	Tube, 4.80 x 8, Straight Valve Stem	3
3-30	11-040-00	Tube, 5.70 x 8, Straight Valve Stem (For 6.50 x 8 Tire)	3
3-30	13-989-00	Valve Stem (For Tubeless Tires)	3
3-31	13-734-00	Tire and Demountable Wheel, 4.80 x 8, 4 Ply Tubeless Super Rib Tire with Five 1/2" Holes on 4-1/2" Bolt Circle on Wheel.	2
3-31	13-739-00	Tire, Tube and Demountable Wheel, 4.80 x 8, 6 Ply, Steelguard tire with Five 1/2" Holes on 4-1/2" Bolt Circle on Wheel	3
3-31	13-748-00	Tire and Demountable Wheel, 16 x 6.50 x 8, 4 Ply Terra Tire, Traction with Five 1/2" Holes on 4-1/2" Bolt Circle on Wheel.	2
3-311	13-861-00	Tire and Demountable Split Wheel Zero Pressure 16 x 4.00 H.S. with Five 1/2" Holes on 4-1/2" Bolt Circle, Black	1
3-31	13-862-00	Tire and Demountable Split Wheel Zero Pressure 16 x 4.00 H.S. With Five 1/2" Holes on 4-1/2" Bolt Circle, Gray, Non-Marking	1
3-32	12-045-00	Wheel for 16 x 6.50 x 8 Tire, Demountable, Drop Center, Off Center Mount, Five 1/2" Holes on 4-1/2" Bolt Circle	2
3-32	12-012-00	Wheel for 4.80 x 8 Tubeless, Tire, Five 1/2" Holes on 4-1/2" Bolt Circle (Used for Steelguard Tire)	1
3-32	12-041-00	Wheel for 4.80 x 8 Tire and 16 x 400 Zero Pressure Tire, Demountable, H.D., Split Disk, Five 1/2" Holes on 4-1/2" Bolt Circle	1
3-33	12-050-00	Wheel for 16 x 4 x 12-1/8 Solid Cushion Tire, Five 1/2" Holes on 4-1/2" Bolt Circle.	1
3-33	12-054-00	Wheel for 16-1/4 x 4 x 11-1/4 Solid Cushion Tire, Five 1/2" Holes on 4-1/2" Bolt Circle	1
3-34	10-261-00	Tire, Solid Xtra Cushion, All Service, 16-1/4 x 4 x 11-1/4	3
3-34	10-250-00	Tire, Solid Cushion, Smooth, 16 x 4 x 12-1/8	3
3-35	13-952-10	Tire and Demountable Cast Iron Wheel with 16 x 4 x 12-1/8 Solid Cushion Tire	1
3-35	13-954-10	Tire and Demountable Cast Iron Wheel with 16-1/4 x 4 x 11-1/4 Solid Xtra Cushion, All Service Tire.	1

GEARED STEERING ASSEMBLY
FOR MOD. '55 WITH STEERING UNIT

FIGURE 4A
SECTION J1

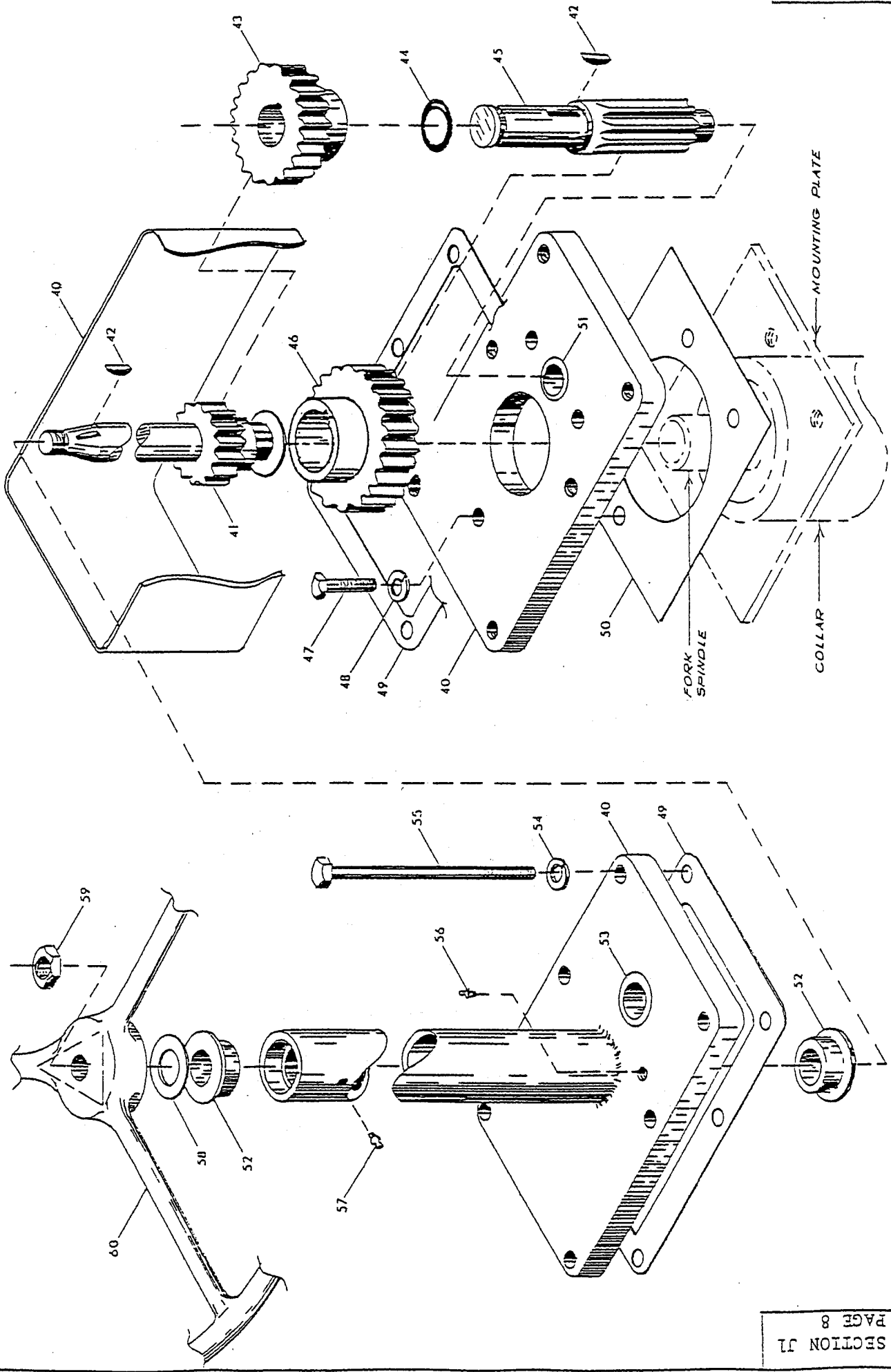

LENGTH QUAN. REVISED DATE REVISION 12-9-81

NO. DESCRIPTION

TOL. FRAC. † DEC. †

SCALE NONE

DRAWN BY FEA

DATE 4-71

GEARED STEERING ASSEMBLY
FOR MODEL SS WITH STEERING WHEEL
REFER TO FIGURE 4A

FIG. I.D. NO.	T-D PART NO.	DESCRIPTION	QTY. REQ.
4A-40	18-309-00	Steering Gear Box Only, with bolts, bushings and grease fittings	1
4A-41	20-031-00	Steering Shaft with Gear	1
4A-42	97-100-00	Woodruff Key - 3/16"	2
4A-43	31-253-00	Spur Gear, 36 Tooth 16 D.P. - 14-1/2° P.A. - 3/4" Bore with Keyway	1
4A-44	80-706-00	O Ring 3/4" O.D.	1
4A-45	31-255-00	Stem Pinion - 7 Tooth	1
4A-46	31-254-00	Spur Gear, 36 Tooth 12 D.P. 14-1/2° P.A. - 7/8" Bore with Keyway	1
4A-47	88-080-11	Hex Head Cap Screw 5/16" x 1" N.C.	3
4A-48	88-088-62	Lock Washer, 5/16	3
4A-49	45-004-00	Gasket (4 x 6 O.D.)	2
4A-50	45-003-00	Gasket (4 x 4-1/2 O.D)	1
4A-51	32-207-00	Bushing, Bronze - 3/8" I.D. x 5/8" O.D. x 1/2" Lg.	1
4A-52	80-405-00	Ball Bearing - 3/4" I.D.	2
4A-53	32-203-00	Bushing, Bronze - 3/4" I.D. x 7/8" O.D. x 1/2" Lg.	1
4A-54	88-068-62	Lockwasher 1/4"	6
4A-55	88-060-24	Hex Head Cap Screw 1/4" x 4" N.C.	3
4A-55	88-060-25	Hex Head Cap Screw 1/4" x 4-1/2" N.C. (with horn)	3
4A-56	87-074-00	Grease Fitting 1/4" - 28 N.F.	1
4A-57	87-071-00	Grease Fitting 3/16 Drive	1
4A-58	16-405-00	Spacer - 3/4" I.D. x 1-1/4" O.D.	1 or 2
4A-59	88-199-82	Nut 5/8 N.F. (Jam)	1
4A-60	19-007-20	Steering Wheel	1

MAINTENANCE PROCEDURES
BELT DRIVE REAR AXLE, MOTOR AND BRAKES
REFER TO FIGURE NO'S. 5 THROUGH 5R

Your drive assembly is a highly efficient unit. Great care was taken in its design to promote long life with a minimum of maintenance. It employs an automotive type differential unit which operates within an enclosed housing. The gears, bearings, etc., are lubricated from within by oil which when maintained at its proper level insures complete coverage of all moving parts. This oil level should be checked on a regular basis as outlined in the Maintenance Guide (Section D) and Lubrication Diagrams (Section E) of this manual. If the oil level is allowed to drop below normal limits, serious damage to the differential and drive unit will result.

An adjustable motor mount has been provided to keep belts or chain properly tensioned. Refer to Section J2D, Page 1 for proper adjustment procedures. It is important to maintain belt or chain tension and alignment as outlined on Page 1. Failure to do so will seriously affect belt life.

The electric motor will provide hours of trouble free services. It is provided with sealed ball bearings which are prelubricated for their lifetime.

Periodically, the motor brushes should be inspected and cleaned. The carbon dust and dirt should be blown out of motor. Approximately 3000 hours operating life may be expected from a new set of brushes. To determine when to replace worn brushes, proceed as follows:

1. For motors equipped with brushes having end pigtailed and side hooks, replace brush when hook is within 1/16" from bottom of hook slot.
2. For motors equipped with brushes having side pigtailed only, replace brush when pigtail is within 1/16" from bottom of pigtail slot.

NOTE: When one brush is replaced in a motor, it is considered good maintenance practice to replace all brushes. Inspect commutator for roughness or undue wear as arcing and shortened brush life will result from this condition.

Refer to Section J2M for detailed service procedure. Check motor wiring terminals for cleanliness and tightness. A loose connection will cause burning of the respective terminal and can induce motor failure. DO NOT PERFORM THIS MAINTENANCE WHILE BATTERIES ARE BEING CHARGED. Refer to Maintenance Guide (Section D) and Service Adjustment (Section J2M) for further recommendations on motor care.

The mechanical brake assembly located on the differential pinion shaft will require a periodic inspection for lining wear and consequently periodic adjustment. Refer to Service and Adjustment Section J2B of this manual for proper procedures. Great care must be taken that no oil is allowed to contact the brake band or drum as it will seriously impair the braking ability. If the braking surfaces become oily or contaminated for any reason it will be necessary to remove the brake band and clean all parts thoroughly. Refer to the appropriate section of this manual for the correct procedure to follow.

A periodic tightening of all bolts and nuts, and especially those which fasten the drive to the chassis, should be made: BUT NOT WHILE THE BATTERIES ARE BEING CHARGED.

For service procedures required to remove drive axle assembly from the vehicle, refer to following pages in Section J2.

SERVICE AND ADJUSTMENTS
BRAKES

REFER TO FIGURE NO'S. 5B & 5D

ADJUSTMENT OF BRAKE BAND TO COMPENSATE FOR NORMAL LINING WEAR

NOTE: If, after performing the following adjustments, braking system does not perform as indicated, the most probable cause is stretching or maladjustment of the brake cable. See Section titled "Replacment or Adjustment of Brake Cable".

1. Adjust brake band anchor bolt, tightening it until brake band engages brake drum with sufficient force to stop vehicle when brake pedal has traveled half-way to the floor board.

NOTE: With the adjustment indicated above, the parking brake is automatically adjusted so that when the lower slot of the pedal engages the locking angle welded to the frame, proper parking brake force is applied.

As the lining wears, pedal travel will increase to the point where the upper slot must engage the locking angle in order to provide proper parking brake force. Brake band adjustment MUST be made before lining wear reaches the point where engagement in the upper slot fails to provide adequate parking brake force.

REMOVAL OF BRAKE ASSEMBLY AND DRUM

1. Disengage spring from brake lever bar.
2. Remove cotter pin and clevis pin from brake band.
3. Remove brake band anchor bolt, and remove brake band.
4. Band and drum may now be cleand, inspected, and if necessary parts may be replaced as needed.
5. Brake band lining is bonded to the band for long dependable service. When it wears to approximately 1/16" thickness the band should be replaced.
6. If the brake drum is scored, it should be removed and turned. It is recommended that a brake drum that has been severly scored or damaged should be replaced with a new drum.
7. Reassemble drum and specer on pinion shaft. Tighten to 100 lb. ft. torque.
8. Replace brake assembly in the reverse order from which it was removed.
9. Adjust brake band.

REPLACEMENT OR ADJUSTMENT OF BRAKE CABLE

1. To replace disengage brake lever arm return spring from brake lever arm, disconnect brake cable from linkage at each end of cable.
2. Assemble adjustable end of cable to brake pedal bell crank with clevis pin and cotter pin.
3. Check brake band adjustment. Band must be loose on drum. Adjust length of cable so that with brake lever arm (located below brake drum) pivoted rearward as far as possible, the slack is just barely removed from the cable when cable is assembled to brake lever arm.
4. Secure cable fitting to brake lever arm with clevis pin and cotter pin and install brake lever arm return spring to brake lever arm.
5. Adjust brake band as outlined

* CAUTION: Never bend the brake band anchor bolt. Any bending of the bolt may result in unexpected failure of the bolt and complete loss of Drive Line braking Action.

NO.	DESCRIPTION
TOL. FRAC. ±	DEC. ±
SCALE	NONE
DRAWN BY	B.B.
DATE	12-22-80

FIGURE 5B
SECTION J2B

LENGTH	QUAN.	REVISED DATE	REVISION
MECHANICAL BRAKE			

TAYLOR DUNN MFG. CO.
2114 West Ball Rd.
Anaheim, Calif.

SEE SECTION J4 - BRAKE CABLE INFORMATION

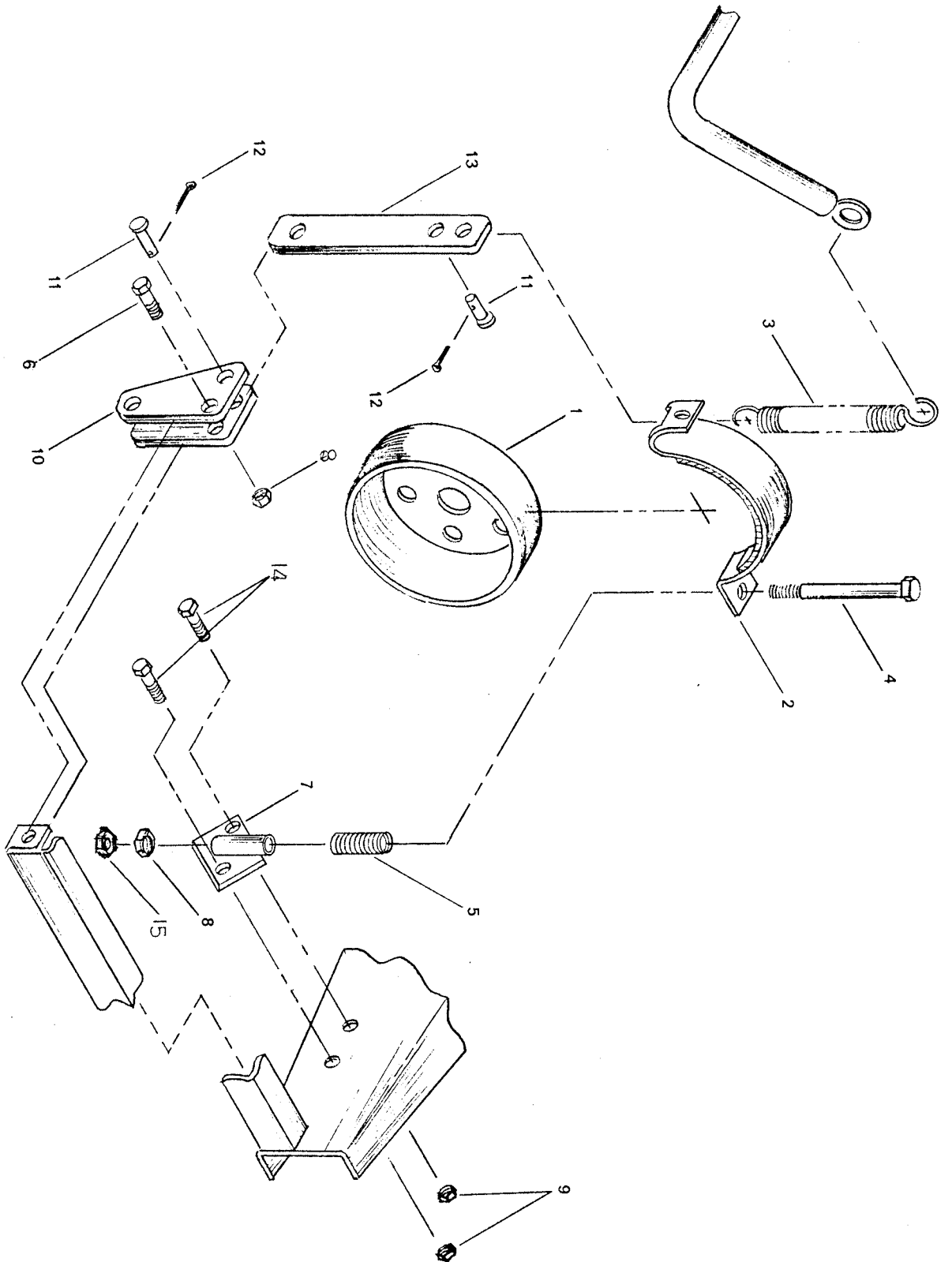

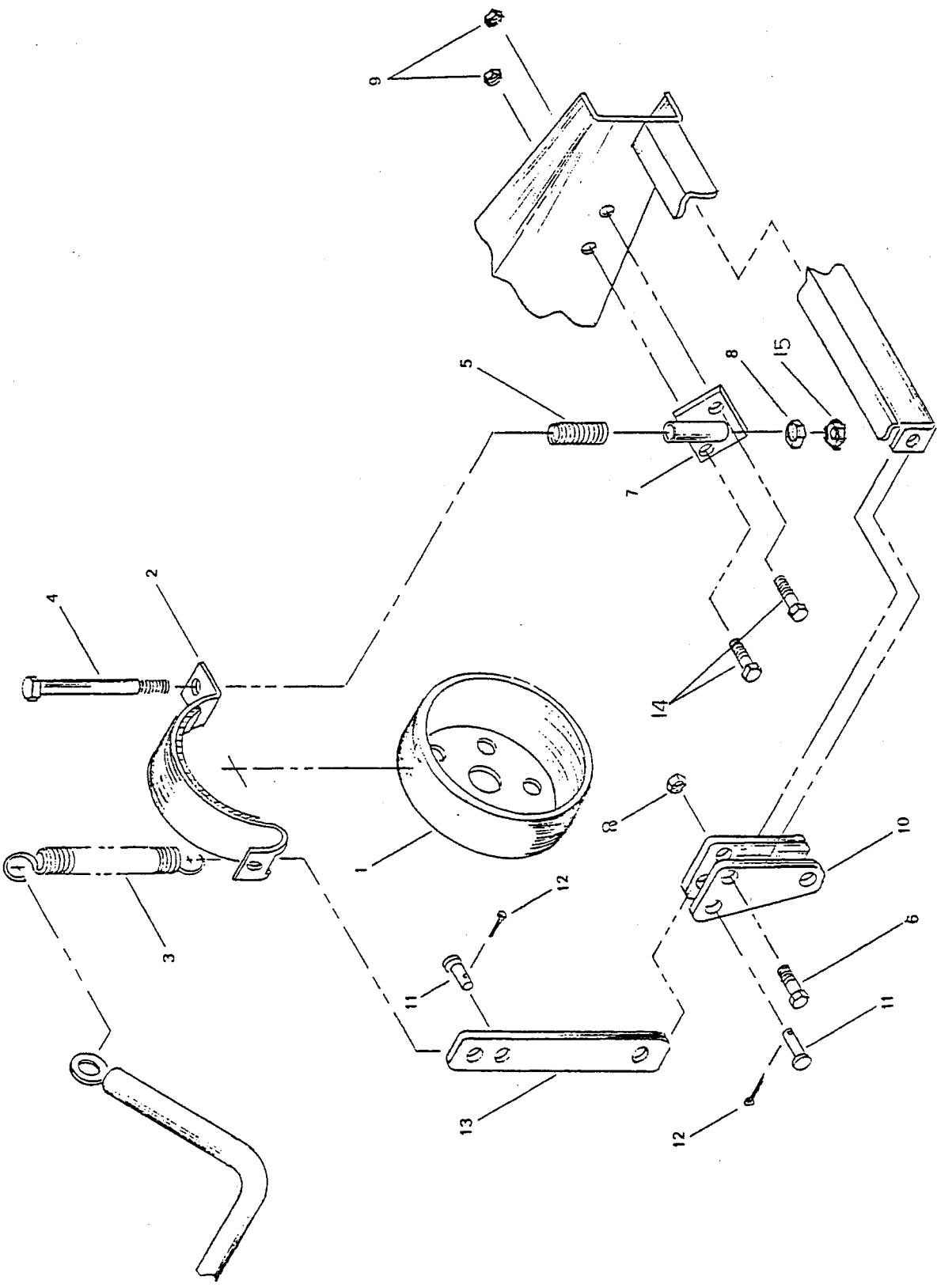

SEE SECTION J4 - BRAKE CABLE INFORMATION

SECTION J2B
PAGE 2

NO.	DESCRIPTION		LENGTH	QUAN.	REVISED DATE	REVISION
	TOL. FRAC. ±	DEC. ±				
SCALE	NONE					
DRAWN BY	B. B.					
DATE	2-22-60					
FIGURE 5B SECTION J2B			MECHANICAL BRAKE			
TAYLOR DUNN MFG. CO. 2114 West Ball Rd. Anaheim, Calif.						

MECHANICAL BRAKEREFER TO SECTION 5B

FIG. I.D. NO.	T-D PART NO.	DESCRIPTION	QTY. REQ.
5B-1	41-532-00	Brake Drum, Machined Broached	1
5B-2	41-660-61	Kit, Brake Band with Anchor Bolt & Nuts	1
5B-3	85-270-00	Spring, Extension 1-1/4 OD X 4-3/8 Free Length	1
5B-4	96-245-00	Hex Head Cap Screw 3/8 NC X 4-15/16, Grade 5 Thread	1
5B-5	85-060-00	Spring Compression 5/8 OD X 2-1/2	1
5B-6	88-100-11	Hex Head Cap Screw 3/8 NC X 1-3/4	1
5B-7	41-380-00	Brake Mounting Bracket	1
5B-8	88-109-81	Lock Nut 3/8 NC	2
5B-9	88-089-81	Lock Nut 5/16 NC	2
5B-10	50-662-00	Brake Lever, Belt Drive	1
5B-11	96-771-00	Pin, Clevis 3/8 X 3/4" From Face to Hole	2
5B-12	88-517-11	Cotter Pin, Steel 3/32 X 1" Long	2
5B-13	50-661-00	Brake Lever Bar	1
5B-14	88-080-11	Hex Head Cap Screw, 5/16 NC x 1	2
5B-15	88-109-80	Hex Nut 3/8 NC	1

SERVICE AND ADJUSTMENTS
DRIVE BELTS, PULLEYS & MOTOR MOUNTS

REFER TO FIGURE 5D

REPLACEMENT OF BELTS

New belts will "seat in" rapidly after a few operating hours. Therefore, inspection and readjustment of belt tension will prevent undue slippage and abnormal wear. It may be necessary that this readjustment will be repeated two or three times in the first two weeks of operation until new belts become thoroughly "seated in".

1. CAUTION: Disconnect both main positive and negative battery leads to prevent accidental engagement of power while servicing unit.
2. Remove brake band anchor bolt and spring.
3. Loosen motor mount clamp nuts slightly.
4. Loosen motor adjusting bolt lock nut and turn adjusting bolt in until belts can be easily lifted from pulley grooves without prying or forcing. Remove belts.
5. Install a full set of new belts of equal length. Replacement of only a part of the set will prevent obtaining proper tension of all belts. This will cause unequal division of load among the abnormal wear as a result.
6. Adjust tension and alignment as described below.
7. Reassemble brake band and adjust as described in Section J2B.

BELT TENSION ADJUSTMENT AND ALIGNMENT

1. CAUTION: Disconnect both main positive and negative battery leads to prevent accidental engagement of power while servicing unit.
2. Loosen motor mount clamp nuts slightly.
3. Loosen motor adjusting bolt lock nut and turn adjusting bolt in or out as needed to tension belts properly.

NOTE: Belt tension is correct when belts will deflect between 1/4" and 3/8" at the mid point between pulleys. Press each belt firmly at the mid point with your thumb or finger and measure the deflection at the same point.

4. Rotate drive pulley sufficiently so belts will travel at least one full turn and check belt tension again. This will allow belts to seat properly in grooves.
5. Tighten lock nut on tension adjustment bolt, holding bolt in position with one wrench while tightening lock nut with second wrench.
6. Check pulley alignment with straight edge. If misaligned move motor forward or rearward on its mounting bracket to bring pulleys into alignment. If necessary tap motor mount bracket into position with soft hammer.
7. Retighten motor mount clamp nuts securely.

REMOVE AND INSTALL MOTOR

1. Disconnect battery leads to prevent accidental engagement of power while servicing unit.
2. Clearly mark motor leads to assure proper location when reassembling. Remove motor leads from motor.
3. Loosen motor mount clamp.
4. Loosen motor adjusting bolt lock nut and turn adjusting bolt in until belts can easily be lifted from pulley grooves without prying or forcing. Remove belts from motor pulley.
5. Remove motor mount clamp nuts and clamp. Remove motor and mounting bracket from axle housing.
6. If installing new motor, remove motor shaft nut, pulley, and key from old motor. Also remove motor mounting brackets and screws. For information on maintenance of motor, refer to subsections titled "Motor Maintenance" and "Motor Disassembly and Reassembly".
7. If installing new motor, assemble pulley, key, and shaft nut. Tighten shaft nut to 75 ft.-lb torque.
8. Reassemble to drive assembly in reverse order. Adjust and align belts as described in subsection titled "Belt Tension Adjustment and Alignment".
9. Connect Motor Leads as Follows: (IMPORTANT!!)
 - a) Check that each motor terminal stud nut is tightened securely but not over-tightened as this could bend or twist the terminal post and cause an electrical short within the motor.
 - b) Install motor leads on correct motor terminals post.
 - c) Install a second nut on each terminal post and finger tighten.
 - d) To avoid bending, twisting or breaking-off a terminal post use a thin pattern 9/16" wrench to hold the bottom nut from moving while tightening the top nut. Carefully tighten the top nut so as to make a good connection between the terminal post and motor lead.
 - e) Soldering field coil leads to aluminum field stud should be done in the following manner: Remove from vehicle, disassemble motor, thoroughly clean areas to be joined of all solder, and residue using heat to soften solder, then wire brush, (a stainless steel wire brush is recommended, since it will not oxidize or leave unwanted residue), which could result in a weak solder connection.

Field stud must be in vertical position with joint to be soldered pointing upward, the field coil lead then laying horizontally in stud slot as shown. Apply heat to shoulder of Field Stud approximately 1/2 inch below joint to be soldered, apply solder to both sides of the coil lead, after all solder is applied, remove heat, add flux vigorously and generously to joint until solder flows throughout joint. It is recommended that the MG460 soldering kit, part no. 70-210-63 be used for this repair sequence.

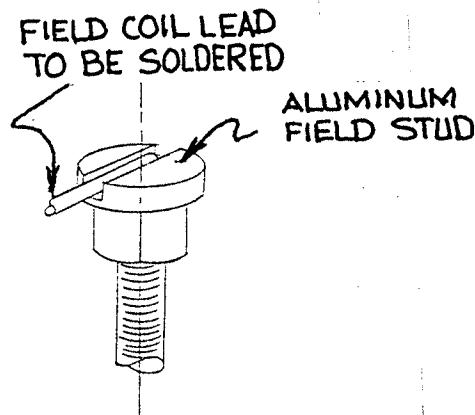

DISASSEMBLE AND REASSEMBLE OF BELT DRIVE ASSEMBLY

1. Perform steps 1 through 5 in subsection titled "Remove and Install Motor" (Section J2M), and steps 1 through 3 in subsection "Removal of Brake and Drum" (Section J2B).
2. Remove belts, and remove pinion shaft nut, washer, brake drum, and pulley, from pinion shaft.
3. Before reassembly, inspect seal in pinion bearing retainer, and replace if damaged or worn. It is recommended that the new seal be pre-soaked in light oil for several hours before installation, and that a small amount of oil resistant sealer be applied to the opening in the pinion bearing retainer.
4. Reassemble in reverse order. Adjust bolt tension and alignment, and adjust brakes.

NOTE: For service and Adjustment of Motor see subsection J2M.

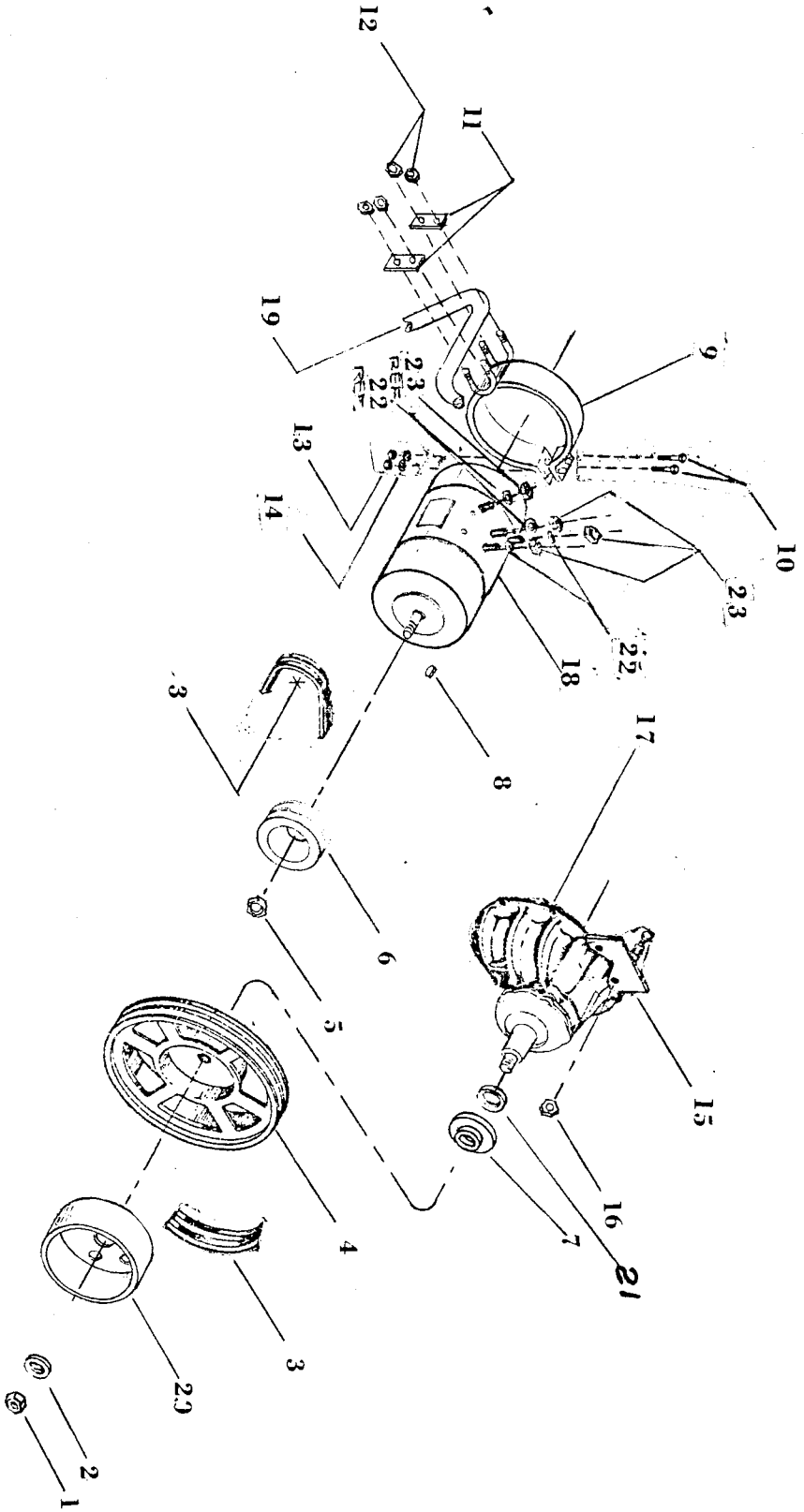

NO. DESCRIPTION

LENGTH QUAN. REVISED DATE REVISION

TOL. FRAC. ± DEC. ±

FIGURE NO. 5D

BELT DRIVE

SCALE NONE

DRAWN BY B.B.

SECTION J2D

DATE 7-20-81 JES



TAYLOR DUNN MFG. CO.
2114 West Ball Rd.
Anaheim, Calif.

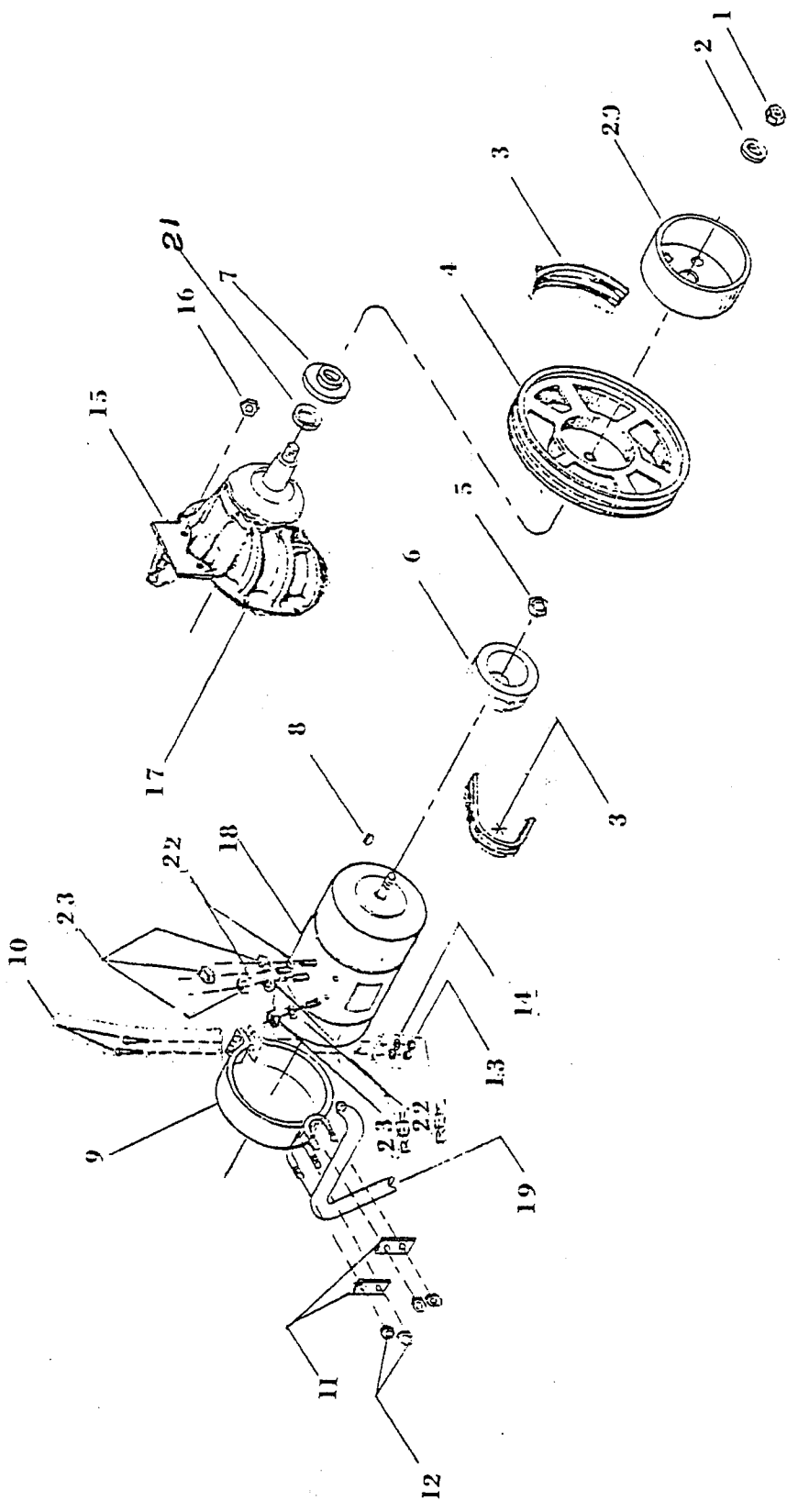

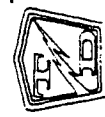
NO.	DESCRIPTION	LENGTH	QUAN.	REVISED DATE	REVISION
	FIGURE NO. 5D SECTION J2D				BELT DRIVE
	TOL. FRAC. ± DEC. †				
	SCALE NONE				
	DRAWN BY B.B.				
 TAYLOR DUNN MFG. CO. 2114 West Ball Rd. Heim, Calif.					

BELT DRIVEREFER TO FIGURE 5D

FIG. I.D. NO.	T-D PART NO.	DESCRIPTION	QTY. REQ.
5D-1	97-250-00	Nut-Pinion 3/4-20 Extra Fine Thread	1
5D-2	88-228-61	Washer SAE 3/4	1
5D-3	30-601-00	Belt, AX-33 (With 8" Pulley)	2
5D-3	30-613-00	Belt, AX-38 A-Section (With 11" Pulley)	2
5D-4	30-116-00	Pulley, 8" O.D.	0 or 1
5D-4	30-117-00	Pulley, 11" O.D.	0 or 1
5D-5	88-239-82	Nut, Hex Jam 3/4 N.F. (Not used on 7/8 Bore Pulley)	0 or 1
5D-6	30-114-00	Pulley, Motor, 2 Belt, 2-1/4 O.D., 3/4 Bore	0 or 1
5D-6	30-115-00	Pulley, Motor, 2 Belt, 2-3/4 O.D., 3/4 Bore	0 or 1
5D-7	45-339-00	Oil Seal, Pinion Shaft, 3" O.D.	0 or 1
5D-7	45-340-00	Oil Seal, Pinion Shaft, 4-1/8" O.D.	0 or 1
5D-8	97-100-00	Woodruff Key - 3/16	1
5D-9	70-434-61	Kit, Swivel Motor Mount with Hardware	1
5D-10	88-101-18	Hex Head Cap Screw, 3/8 N.C. x 2-1/2 Long	2
5D-11	70-422-00	Motor Mount Strap, 1-7/8 Long	2
5D-12	88-109-87	Nut, Fastite, 3/8 N.C.	4
5D-13	88-109-80	Nut, Hex, 3/8 N.C.	2
5D-14	88-108-62	Lock Washer, 3/8	2
5D-15	41-381-00	Motor Adjustment Bracket	1
5D-16	88-119-80	Nut, Hex 3/8 N.F.	2
5D-17		Sub Assembly Refer to Section J2R	
5D-18		Sub Assembly Refer to Section J2M	
5D-19		Sub Assembly Refer to Section J2H	
5D-20		Sub Assembly Refer to Section J2B	
5D-22	88-088-62	Lock Washer, 5/16	4
5D-23	88-089-82	Nut, Hex 5/16-18 NC Brass	4

MAINTENANCE, SERVICE AND ADJUSTMENT
REAR AXLE AND HOUSING

REFER TO FIGURE 5H

The rear axles combined with the differential is enclosed in housing unit. Extra effort has been spent in giving your vehicle a rugged, reliable and simple drive system, a part of which is the integration of the automotive type axle. Given proper care and maintenance, it will offer you trouble free service during the whole life time of your vehicle.

A simple maintenance procedure is detailed below.

INSPECTION, REMOVAL AND INSTALLATION OF REAR WHEEL AXLE AND BEARINGS

1. CAUTION: Disconnect both main positive and negative battery leads to prevent accidental engagement of power while servicing vehicle.
2. Remove wheel and tire assembly.
3. Remove four bolts attached to axle retainer plate and pull axle out of housing.
4. Remove bearing gasket and inspect ball bearings. If bearing shows signs of roughness and play, pull bearing ring and bearing from axle shaft. Inspect axle for metal fatigue, leave axle retainer plate on the axle shaft.
5. Press new bearing to shoulder on axle shaft. Press new bearing retainer ring into position on axle shaft.
6. Install new gasket over bearing retainer ring.
7. Install axle into axle housing and differential assembly.
8. Install axle retainer plate to axle housing with four studs. Tighten lock nuts.
9. Install wheel and tire assembly.
10. Reconnect battery leads

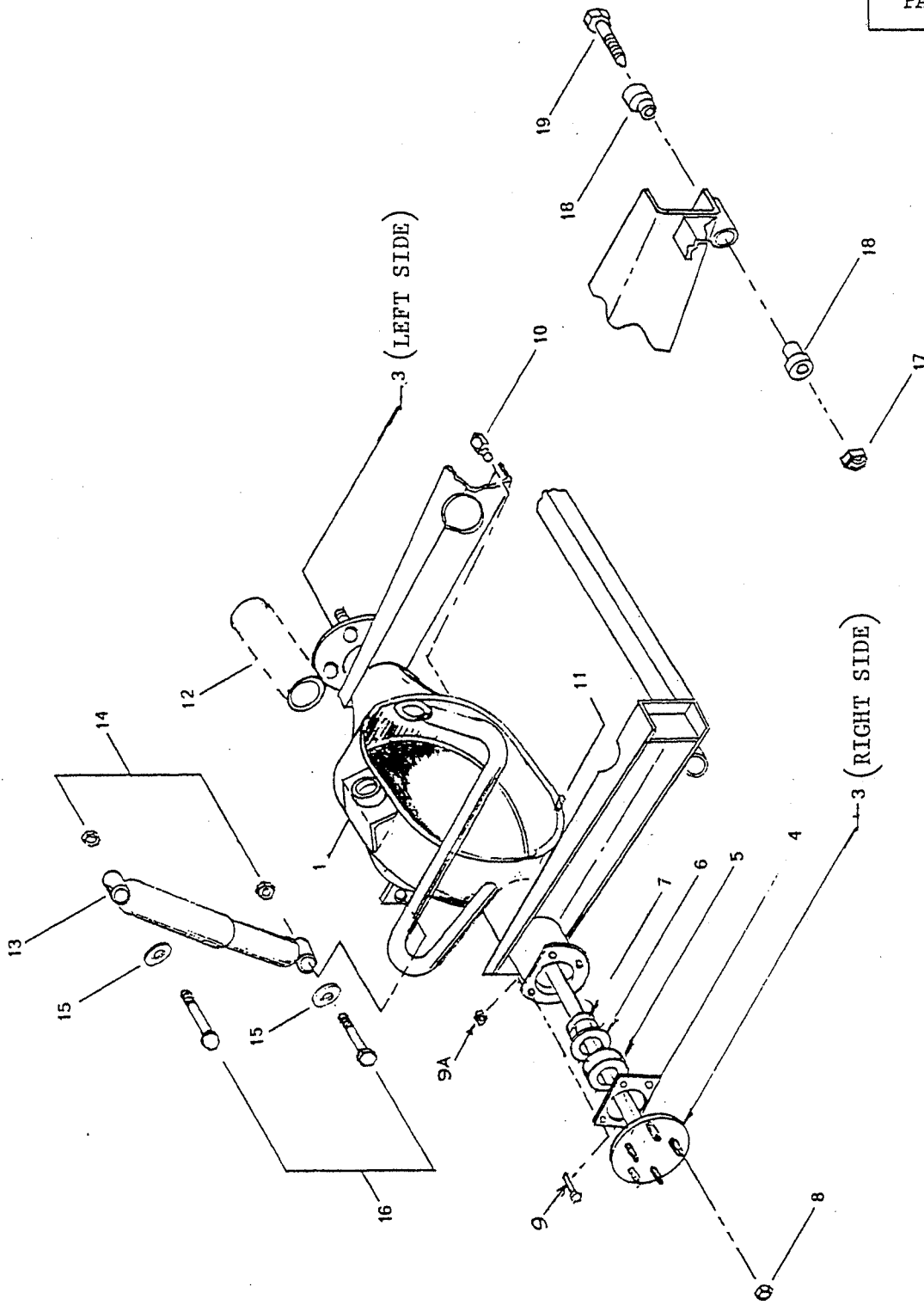

TAYLOR DUNN MFG. CO.
2114 West Ball Rd.
Anaheim, Calif.

REAR AXLE AND HOUSING REVISION 5-2-82 JPB

REAR AXLE AND HOUSING

FIGURE 5H
SECTION J2H

SECTION J2H
PAGE 2

NO.	DESCRIPTION
TOL: FRAC. ±	DEC. ±
SCALE	NONE
DRAWN BY	B.B.
DATE	4/80

REAR AXLE AND HOUSING
REFER TO FIGURE 5H

FIG. I.D. NO.	T-D PART NO.	DESCRIPTION	QTY. REQ.
5H-1	41-296-00	Housing, Rear Axle with Bolts	1
5H-3	41-166-11	Axle Assembly, Left Side 10-7/8 Long with Large Bearing and Retainer Plates.	1
5H-3	41-165-11	Axle Assembly, Right Side 13-1/4 Long with Large Bearing and Retainer Plates.	1
5H-4	32-514-00	Retainer Plate, Rear Axle	1
5H-5	80-503-00	Ball Bearing, Rear Axle	2
5H-6	45-045-00	Gasket, Rear Axle Bearing to Housing used with 1-9/16 I.D. Wheel Bearing (2 I.D.)	0 or 2
5H-7	45-301-00	Oil Seal	2
5H-8	97-736-00	Lug nut, 1/2" Tapered	10
5H-9	88-120-11	Hex Head Cap Screw 7/16 N.C. x 1 Long	8
5H-9A	88-129-81	Lock Nut, 7/16 NC	8
5H-10	41-997-00	Fill Level or Drain Plug (1/8 Pipe)	3
5H-11	96-330-00	Bolt, Differential Carrier to Housing	10
5H-12	85-140-00	Spring, 2-7/16 O.D. x 6-1/4 (.362 Diameter Wire)	1
5H-13	86-602-00	Shock Absorber	1
5H-14	88-189-81	Lock Nut 5/8 Hex	2
5H-15	88-188-61	Washer 5/8, SAE	2
5H-16	88-180-18	Hex Head Cap Screw 5/8 N.C. x 2-1/2 Long	2
5H-17	88-149-81	1/2 N.C. Lock Nut	2
5H-18	98-601-00	Grommet, Rubber 1/2" I.D.	4
5H-19	96-240-00	Bolt with Pointed End - 1/2 x 4" Long	2

MOTOR MAINTENANCE, SERVICE AND ADJUSTMENT
ELECTRIC MOTORS
REFER TO FIGURE 5H

Detailed service procedures covering maintenance of bearing brushes and commutator are covered in this section. DO NOT PERFORM THIS PROCEDURE WHILE BATTERIES ARE BEING CHARGED.

Maintenance of electric motors should be referred to personnel with experience and equipment. Should it be necessary for you to order replacement parts for your motor. IT IS NECESSARY TO INCLUDE COMPLETE NAMEPLATE DATA WITH ORDER.

MOTOR MAINTENANCE - BRUSH INSPECTION AND REPLACEMENT

1. Remove cover, exposing brush assemblies. Lift brush from holder for inspection.
2. If brushes are worn, remove, install new brushes. Use fine sandpaper to "Seat in" new brushes to commutator. To determine when to replace worn brushes, proceed as follows:
 - a. For motors equipped with brushes having end pigtails and side hooks, replace brush when hook is within 1/16" from bottom of hook slot.
 - b. For motors equipped with brushes having side pigtails only, replace brush WHEN PIGTAIL IS WITHIN 1/16" from bottom of pigtail slot.

NOTE: When one brush is replaced in a motor, it is considered good maintenance practice to replace all brushes.

3. Check operation of each brush to assure that brush slides freely and does not bind in holder.
4. Replace Cover.

MOTOR DISASSEMBLY AND REASSEMBLY

1. Remove motor from vehicle as described in section J2.
2. determine if witness marks on end bell and stator housing are present. If not, mark end bell and housing to assure proper relation of brushes and commutator when reassembling.
3. Remove cover, exposing brush assemblies. Lift brushes from brush holder.
4. Remove bolts holding end bells and remove end bell and rotor. (Pull from shaft extension end). Take care not to damage any coils or armature wires when handling motor parts.
5. Press or pull old bearings off by using bearing press or bearing puller. Do not damage shaft while removing bearings.
6. Install new bearings onto shaft by gentle pressure or tapping with proper tool on inner race only. Bearing will be damaged if pressed or driven by outer race or seals.
7. If the commutator is worn or "burned" it should be turned, the mica undercut and the commutator polished.
8. Oil bearing housing lightly to aid in reassembly.
9. Reassemble motor taking care that all parts are kept clean.
10. Install brushes and "seat in" with fine sandpaper.
11. Check operation of each brush to assure that brush slides freely in holder.
12. Replace cover.
13. Reassemble to vehicle as described in preceding subsection.

NOTE: If motor terminal studs were removed for inspection, refer to Section J2D, P.2, item 9 for correct procedure to avoid damaging studs.

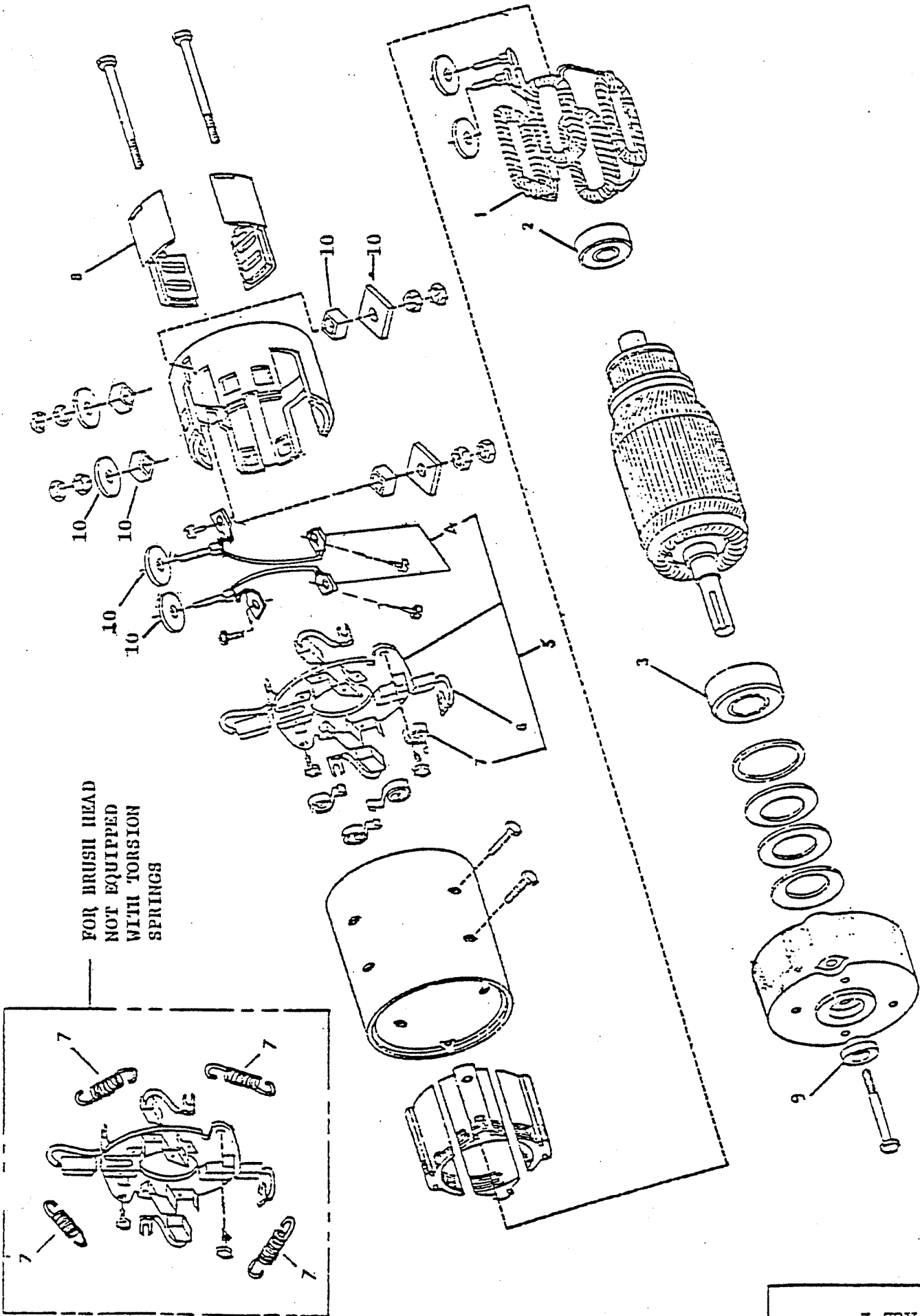

TAYLOR DUNN MFG. CO.
2114 West Ball Rd.
Belmont, Calif.



MOTOR PARTS - G.E. MOTORS

FIGURE 5M
SECTION J2M

DRAWN BY J.W.

ELECTRIC MOTORS
REFER TO FIGURE 5M

For D.C. Motor replacement parts, IT IS NECESSARY TO INCLUDE COMPLETE MOTOR NAME PLATE DATA WITH THE ORDER.

FIG. I.D. NO.	T-D PART NO.	DESCRIPTION	QTY.
------------------	-----------------	-------------	------

Replacement parts for G.E. Motor 5BC48JB503, 5BC48JB531, 5BC48JB550 and 5BC48JB582

5M-1	70-201-00	Field Coil Set (not used on G.E. Motor 5BC48JB582)	1
5M-1	70-202-00	Field Coil Set (For G.E. Motor 5BC48JB582)	1
5M-2	80-200-00	Ball Bearing - Commutator End	1
5M-3	80-504-00	Ball Bearing - Pulley End	1
5M-4	70-195-00	Set of two armature terminal & brush pair connectors, <u>not used</u> on motor 5BC48JB550 with suffix letter "C" or "D". Two required per motor. (included in 70-188-00)	2
* 5M-4	70-196-00	Armature terminal & brush pair connector, <u>used only</u> with motor 5BC48JB550 with suffix letter "C" or "D". Two required per motor. (included in 70-184-00).	2
5M-5	70-184-00	Brush holder, without brushes, including brush springs, armature terminal & brush pair connectors. <u>Used only</u> on motor 5BC48JB550 with suffix letter "C" or "D".	1
5M-5	70-188-00	Brush holder, without brushes, including brush springs, armature terminal & brush pair connectors. <u>Not used</u> on motor 5BC48JB550 with suffix letter "C" or "D"	1
5M-6	70-101-00	Motor Brush	4
5M-7	85-412-00	Brush Spring, Torsion	4
5M-8	30-801-00	Brush Inspection Cover	4
5M-9	45-506-00	Oil Seal	1
5M-10	70-210-62	Motor Terminals Insulator Kit	1

Replacement parts for G.E. Motors 5BC48JB251 & 5BC48JB265

5M-2	80-200-00	Ball Bearing, Commutator End	1
5M-3	80-504-00	Ball Bearing, Pulley End	1
5M-5	70-185-00	Brush Holder Assy.	1
5M-6	70-100-00	Motor Brush	4
5M-7	85-401-00	Brush Spring, Extension	4
5M-9	45-506-00	Oil Seal	1

Replacement Parts For G.E. Motor 5BC48JB726

	70-204-00	Field Coil Set	1
	80-209-00	Ball Bearing, Commutator End	1
	80-504-00	Ball Bearing, Pulley End	1
	70-172-00	Brush Holder Assy. <u>With</u> Brush Springs <u>But Without</u> Brushes	1
	85-412-00	Spring, Brush	4
	70-104-00	Armature Terminal & Brush Pair Connector	2
	45-506-00	Oil Seal	1

Brush Measurement Procedure For 726 Motor

With new brushes, A 1/16" drill rod can be inserted approximately .76" into brush measurement holes. Brushes should be replaced when rod can be inserted 1.56" into hole. This leaves approx. 1/8" allowable wear remaining.

* NOTE: This part replaces strap type 3 HP armature terminal and is 2-way interchangeable on 2 HP motors only.

FIG. I.D.

NO.	T-D PART NO.	DESCRIPTION	QTY.
Replacement Parts for G.E. Motor 5BC48JB67B & 5BC48JB114			
5M-2	80-205-00	Ball Bearing, Commutator End	1
5M-3	80-204-00	Ball Bearing, Pulley End	1
5M-6	70-100-00	Motor Brush Assy	4
5M-7	80-401-00	Brush Spring, Extension	4
Replacement Parts for T.D. Motor 388P3816 & Baldor 45-39W03, 45 39W16,45-39W19			
5M-2	80-200-00	Ball Bearing, Commutator End	1
5M-3	80-504-00	Ball Bearing, Pulley End	1
5M-5	70-187-00	Brush Head Assy, Complete with Brushes	1
5M-6	70-101-00	Motor Brush	4
5M-8	30-803-00	Brush Inspection Cover	4
5M-9	45-506-00	Oil Seal	1
Replacement Parts for G.E. Motor 5BCG56EA17			
5M-2	80-201-00	Ball Bearing, Commutator End	1
5M-3	80-504-00	Ball Bearing, Pulley End	1
5M-5	70-189-00	Brush Holder Assy	1
5M-6	70-101-00	Motor Brush Assy	4
5M-7	85-412-00	Brush Torsion Spring	4
Replacement Parts for G.E. Motor 5BC49JB122			
5M-2	80-200-00	Ball Bearing, Commutator End	1
5M-3	80-504-00	Ball Bearing, Pulley End	1
5M-4	70-185-00	Brush Holder	1
5M-6	70-100-00	Motor Brush	4
5M-7	85-401-00	Brush Extension Spring	4
5M-9	45-506-00	Oil Seal	1
Replacement Parts for G.E. Motor 5BC49JB305 and *5BC49JB399			
5M-1	70-203-00	Field Coil Set	1
5M-2	80-200-00	Ball Bearing, Commutator End	1
5M-3	80-504-00	Ball Bearing, Pulley End	1
5M-4	70-195-00	Armature Terminal to Brush	2
5M-5	70-188-00	Brush Holder assembly	1
5M-6	70-101-00	Motor Brush	4
5M-7	85-412-00	Brush Extension Spring	4
5M-8	30-802-00	Brush Inspection Cover	4
* 5M-9	45-506-00	Oil Seal	1
5M-10	70-210-62	Motor Terminals Insulator Kit	1
* NOTE:	45-508-00	Oil Seal for 5BC49JB399 only	1

FIG. I.D. NO.	T-D PART NO.	DESCRIPTION	QTY.
Replacement Parts for Taylor-Dunn Motor 388P381A			
5M-2	80-204-00	Ball Bearing, Commutator End	1
5M-3	80-205-00	Ball Bearing, Pulley End	1
5M-5	*70-187-00	Brush Head Assy. Complete with Brushes *Not supplied as original equipment on <u>A</u> series motor but must be used as replacement part.	1
5M-6	*70-102-00	Motor Brush with Wire Hook *Replacement part for original <u>A</u> series motor <u>NOT</u> converted to new brush head assy. 70-187-00.	4
5M-6	70-101-00	Motor Brush for <u>A</u> series motor converted to new brush head 70-187-00.	4
5M-7	*85-413-00	Brush Torsion Spring *Replacement part for original <u>A</u> series motor <u>Not</u> converted to new brush head assy. 70-187-00.	4
5M-9	45-506-00	Oil Seal	1
5M-8	30-802-00	Brush Inspection Cover	1

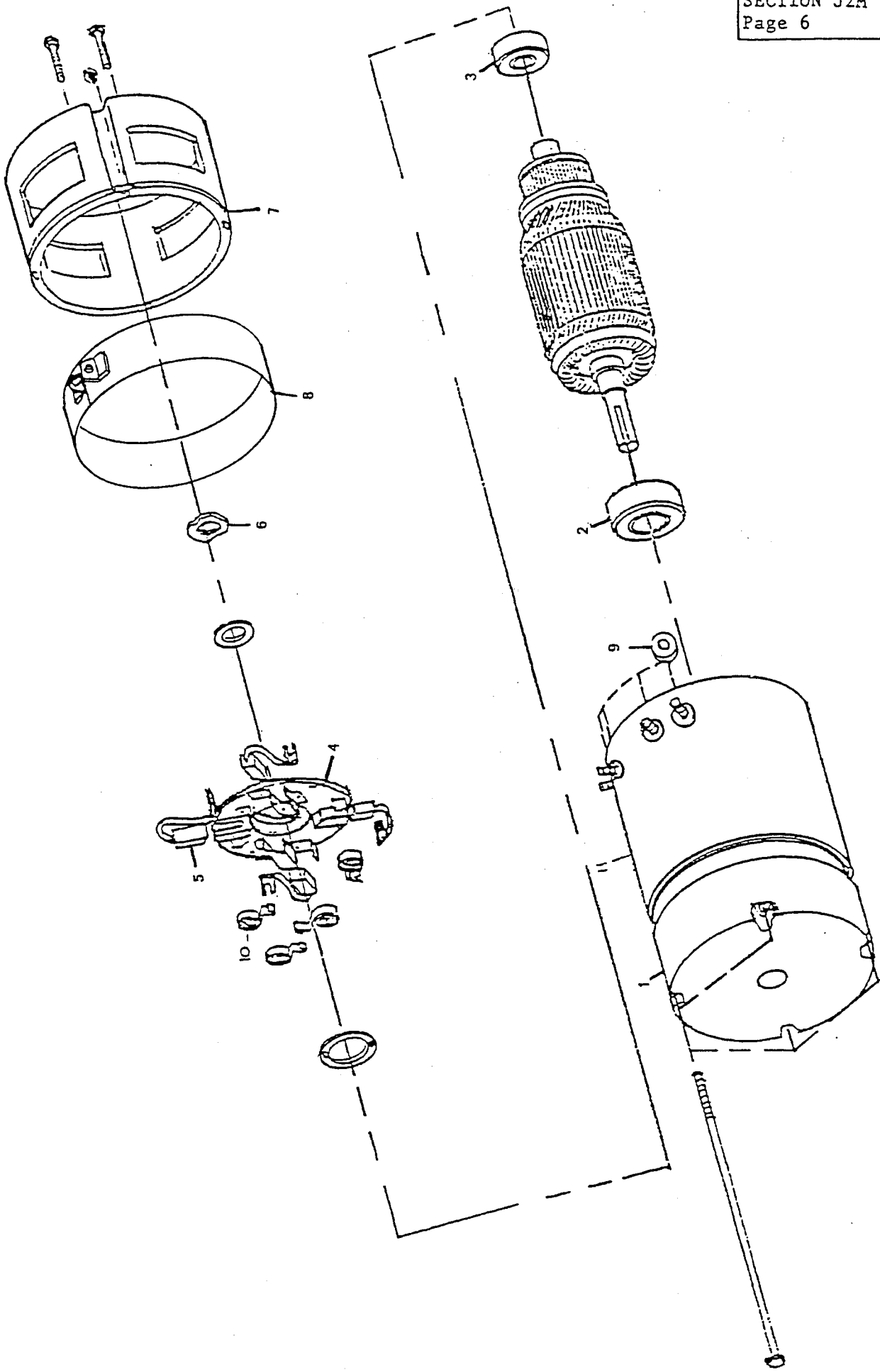

DO NOT SCALE	TOL: FRAC±	DECI	ANG±	3-11-82	11-8-84
	MOTOR PARTS - 3.0 HP BALDOR MODEL SS			SCALE: NONE	DWN BY: BB
 Taylor-Dunn 2114 WEST BALL ROAD ANAHEIM, CALIFORNIA 92803				FIGURE 5N	
				SHEET 1 OF 1	

ELECTRIC MOTOR
REFER TO FIGURE 5N

MODEL SS ONLY

FOR D.C. MOTOR REPLACEMENT PARTS

IT IS NECESSARY TO INCLUDE COMPLETE MOTOR NAME PLATE DATA WITH THE ORDER

FIG. I.D. NO.	T-D PART NO.	DESCRIPTION	QTY. REQ.
Replacement parts for Baldor motor 3.0 h.p. 35P161Z113 T-D Part NO. 70-025-00			
5N-1	70-617-11	END PLATE, PULLEY	1
5N-2	80-504-00	BALL BEARING, PULLEY END	1
5N-3	80-202-00	BALL BEARING, COMMUTATOR	1
5N-4	70-181-50	BRUSH HOLDER, MOUNTING ASSEMBLY	1
5N-5	70-125-00	BRUSH, MOTOR	4
5N-6	30-804-00	WASHER, WAVY	1
5N-7	70-617-10	END PLATE, FRONT	1
5N-8	97-126-00	COVER, BRUSH INSPECTION	1
5N-9	70-210-60	INSULATOR, BUSHING	4

TAYLOR DUNN MFG. CO.
2114 West Ball Rd.
An 'm, Calif.



5BC48JB705

LENGTH | QUAN. | REVISED DATE | REVISION | 11-8-84

MOTOR PARTS - G.E. MOTORS
6.01 > 3/8 DIA. SHAFT

FIGURE 5P
SECTION J2M

NO.	DESCRIPTION
TOL. FRAC. ±	DEC. ±
SCALE	NONE
DRAWN	J.P.B.
DATE	8-21-84

SECTION J2M
PAGE 8

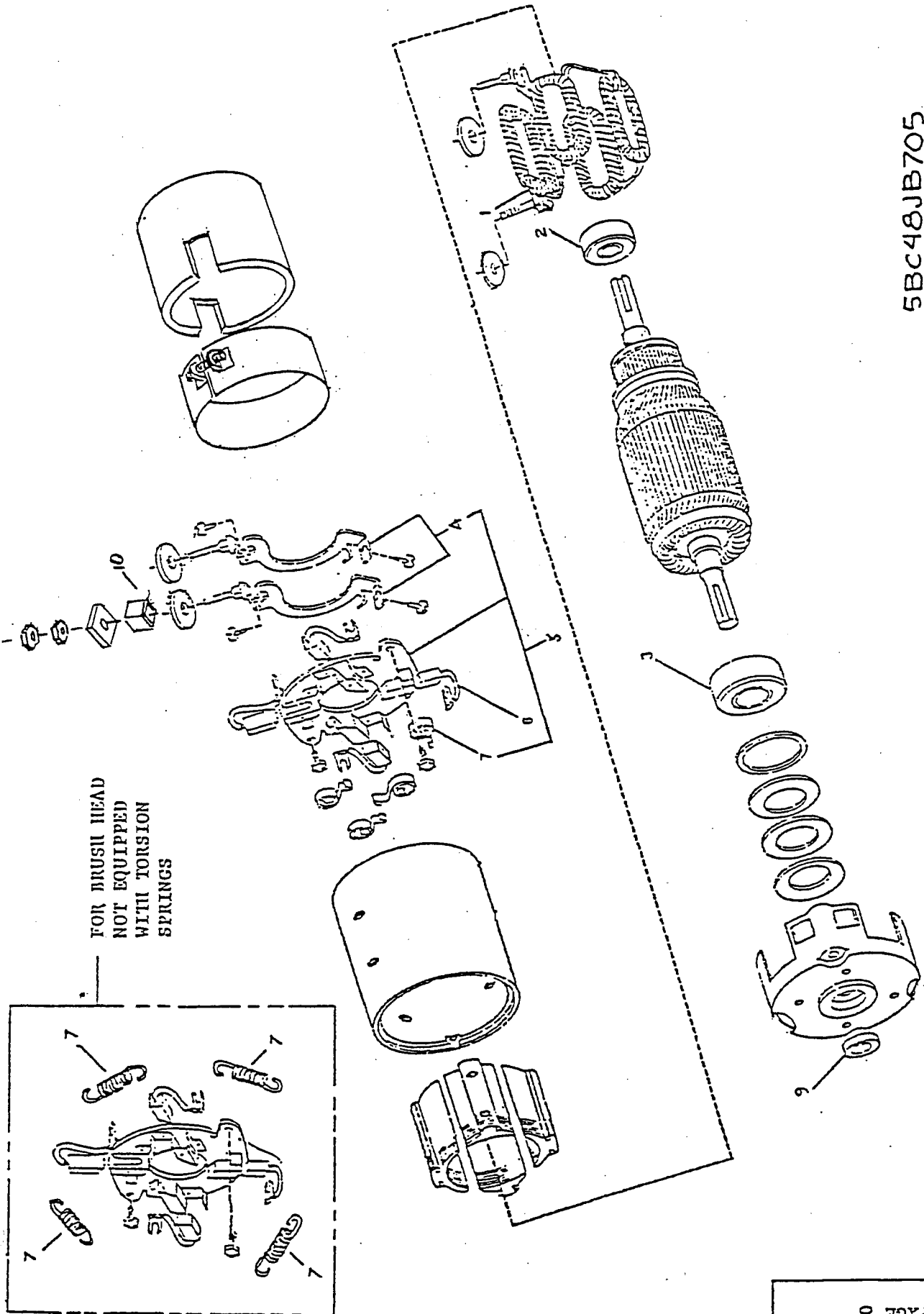

ELECTRIC MOTORS

REFER TO FIGURE 5P

FIG. I.D. NO.	T-D PART NO.	DESCRIPTION	QTY. REQ.
------------------	-----------------	-------------	--------------

REPLACEMENT PARTS FOR G.E. MOTOR 5BC48JB705 6.0 H.P., T-D
PART NO. 70-025-10

NOTE: THIS MOTOR HAS A 7/8" DIAMETER SHAFT AND CAN ONLY BE
USED WITH 7/8" I.D. PULLEYS 30-144-10 AND 30-115-10.

5P-1	70-205-10	FIELD COIL SET	1
5P-2	80-200-00	BALL BEARING-COMMUTATOR END	1
5P-3	80-504-00	BALL BEARING-PULLEY END	1
5P-5	70-172-00	ASSEMBLY WITHOUT BRUSHES	1
5P-6	70-104-00	BRUSH	4
5P-7	85-412-00	SPRING, BRUSH EXTENSION	4
5P-9	45-506-00	SEAL, OIL	1
5P-10	70-210-62	INSULATOR KIT, MOTOR TERMS	1

SERVICE AND ADJUSTMENT
DIFFERENTIAL ASSEMBLY
REFER TO FIGURE 5R & 5H

DISASSEMBLY OF DIFFERENTIAL MEMBER

1. CAUTION: Disconnect both main plus and minus battery leads to prevent accidental engagement of power while servicing unit.
2. Remove rear axle and drive assembly from chassis, and remove primary drive and brake components, as described in appropriate subsections.
3. Remove four bolts on each end holding axle retainer and pull both axles.
4. Remove nuts around differential carrier housing and remove carrier from axle housing. (Note position of clip for proper reassembly of brake spring).
5. Mark one differential bearing cap and bearing support to insure proper assembly. Remove adjusting nut locks, bearing caps, and adjusting nuts. Lift differential out of carrier.
6. Remove drive gear from differential case.
7. Drive out differential pinion shaft retainer and separate the differential pinion shaft and remove gears and thrust washer.
8. Remove drive pinion retainer from carrier. Remove O-Ring from retainer.
9. Remove pinion locating shim. Measure shim thickness with micrometer.
10. If the drive pinion pilot bearing is to be replaced, drive the pilot end and bearing retainer out at the same time. When installing, drive the bearing in until it bottoms. Install a new retainer with the concave side up.
11. Press the pinion shaft out of front bearing cone and remove spacer.
12. Remove pinion bearing cone.
13. Do not remove pinion bearing cups from retainer unless they are worn or damaged. The flange and pilot are machined by locating on these cups after they are installed in the bores. If new cups are to be installed, make sure they are seated in the retainer by trying to insert a .0015" feeler gauge between cup and bottom bore.

REASSEMBLY OF DIFFERENTIAL MEMBER-ALL VEHICLES

1. Differential Case: Place a side gear and thrust washer in the differential case bore. LUBRICATE ALL PARTS LIBERALLY WITH AXLE LUBRICANT DURING ASSEMBLY. With a soft faced hammer, drive pinion shaft into case only far enough to retain a pinion thrust washer and pinion gear. Place the second pinion and thrust washer in position. Drive the pinion shaft into place. Be careful to line up pinion shaft retainer holes. Place second side gear and thrust washer in position and install differential case cover. Install retainer. A pinion or axle shaft spline can be inserted in side gear spline to check for free rotation of differential gears. Insert two 7/16" x 2" bolts through differential flange and thread them three or four turns into the drive gear as a guide in aligning the drive gear bolt holes. Press or tap the drive gear into position. Install and tighten the drive gear bolts evenly and alternately across the gear to 60-65 lb. ft. torque.

REASSEMBLY OF DIFFERENTIAL ASSEMBLY (Cont'd):

2. If the differential bearings have been removed, use a suitable press to install them.
3. Install pinion rear bearing cone on the pinion shaft. Install spacer with shims on the shaft. Place the bearing retainer on the pinion shaft, and install the front bearing cone. Lubricate both bearings with differential oil.
4. Place brake drum and pulley on pinion shaft spline. Assemble washer and shaft nut and tighten to 100 ft. lb. torque.

NOTE: The bearing should spin freely without end play. If it is too tight or too loose, adjust by removing or adding spacers. Refer to Figure 5R I.D. No's. 26 and 27.

5. Shim Selection: Manufacturing tolerances in the pinion bore dimensions and in the best operating position of the gears make an adjustment shim necessary. This shim is placed between the pinion retainer and the carrier, Figure 5. An increase in the thickness of the shim moves the pinion away from the drive gear. Manufacturing objectives are to make axles requiring a .0015" shim and if a new assembly is being built, a .0015" shim should be used for a tentative build-up. Shims are available in .010" to .021" thicknesses in steps of .001". Pinions and drive gears are marked, when matched, with the same number. Following the number on the pinion is a minus (-) or (+) followed by a number. If the pinion is marked "-1" it indicates that a shim .001" thinner than a standard shim for this carrier is required. A minus number means the pinion should be moved closer to the drive gear and a thinner shim is required. A plus number means the pinion should be moved farther from the drive gear and a thicker shim is required. A pinion marked zero (0) is a standard pinion. To select a shim, measure the original shim with a micrometer. Note the dimensional mark on the original pinion. Compare the mark on the original pinion with the mark on the new pinion to determine how the original shim should be modified. For example, if the original shim is .015" and the original pinion is marked "-1", the new pinion requires a +1 shim. Therefore, the new pinion requires a .002" thicker shim, and a .017" shim should be used. If the new pinion is marked the same as the old pinion, no shim change is required.
6. After the proper selection of shims, insert "O" ring seal and pinion retainer assembly into differential carrier. Tighten 5 retainer bolts to 50-lb. ft. torque.

NOTE: Two of the retainer bolts will have to be removed later for installation of belt tension adjuster.

7. Install differential case, bearing cups, adjusting nuts, and bearing caps being sure that each cap is located in the same position from which it was removed (Use marks as guide).

REASSEMBLY OF DIFFERENTIAL ASSEMBLY (Cont'd):

8. Adjust bearing nuts so that differential case will be free to revolve. It is very important that there will be no bearing play or looseness, as this will inevitably lead to gear noise and wear. Gear backlash must be set at the same time to a tolerance of .005" to .009". NOTE: It will be necessary to release some of the cap bolt tension in order to allow the bearings to move while making the adjustments. If the caps are too loose an error will result when trying to set backlash and bearing clearance. Therefore, double check your setting after the cap bolts have been tightened. If necessary make corrections in your settings until the specified tolerances are maintained after the cap bolts have been tightened.
9. Install nut locks.
10. Install differential carrier assembly in axle housing using new gasket and gasket sealer.
11. Install axles, brake assemblies (on models with hydraulic brakes), bearing retainers, and gaskets. NOTE: Axles are equipped with special sealed bearings. Should there be evidence of seal leakage, it is recommended that the bearing be replaced. It is also recommended that gasket located between bearing and bearing seat in axle housing be replaced at the same time. Refer to Figure 5H.
12. Remove pinion shaft nut, washer, brake drum, and pulley. Remove two bolts from pinion bearing retainer which retain motor adjusting bracket. Install motor adjusting bracket and primary drive components as described in subsection titled "Disassemble and Reassemble Primary Drive".
13. Fill housing with oil to level described in Section E.

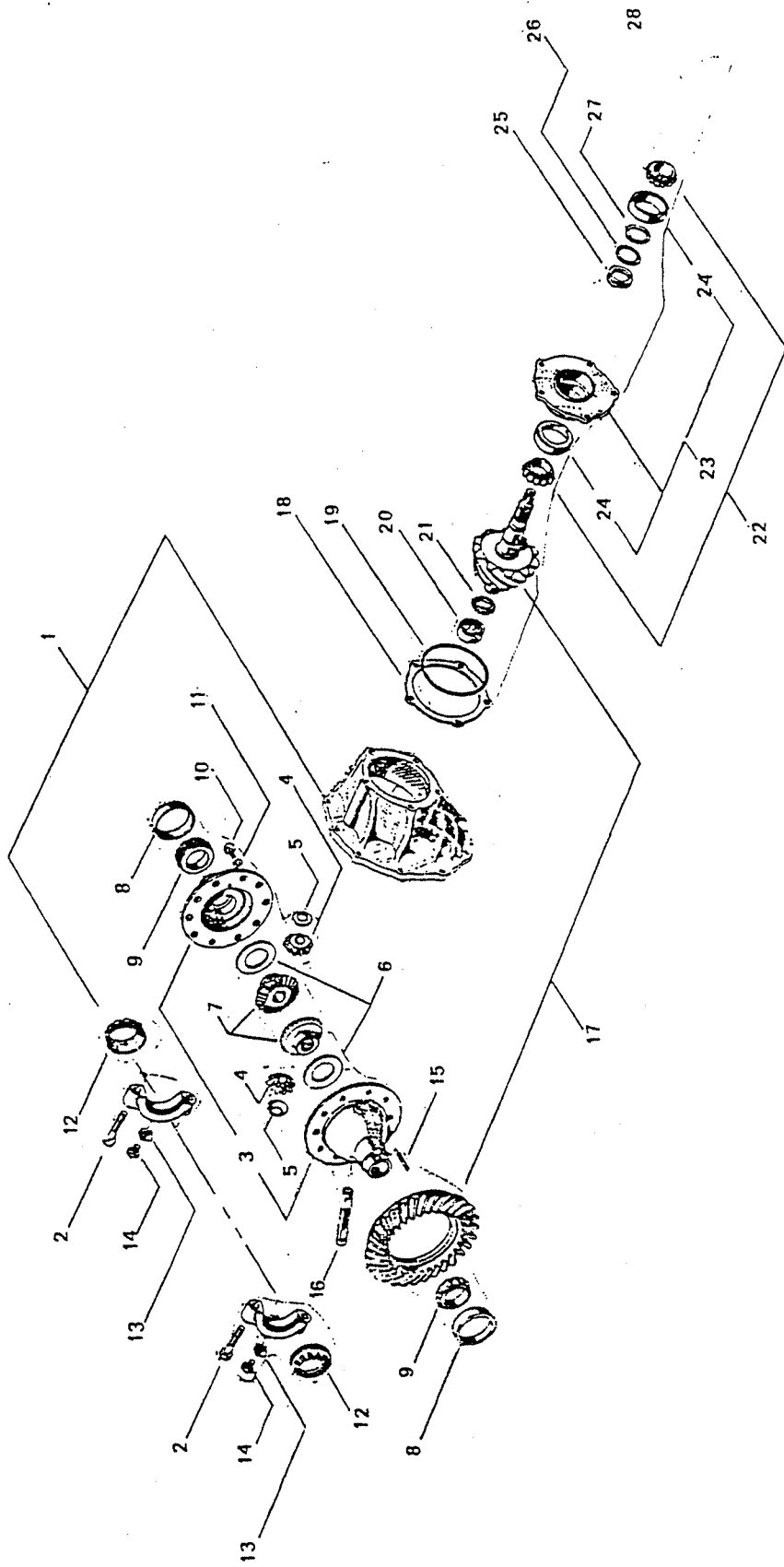

SECTION J2R
PAGE 4

NO.	DESCRIPTION	LENGTH	QUAN.	REVISED DATE	REVISION
	FIGURE 5R SECTION J2R			DIFFERENTIAL	
	TOL. FRAC. ± DEC. ±				
	SCALE NONE				
	DRAWN BY B.B.				
	DATE 11-7-78				

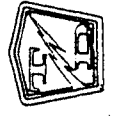

TAYLOR DUNN MFG. CO.
2114 West Ball Rd.
Arheim, Calif.

DIFFERENTIALREFER TO FIGURE 5R

FIG. I.D. NO.	T-D PART NO.	DESCRIPTION	QTY. REQ.
5R-1	41-709-00	Differential Carrier Assembly with Small 1.628 I.D. Carrier Bearing, F2 Axle	1
5R-1	41-710-00	Differential Carrier Assembly with Large 1.784 I.D. Carrier Bearing, F2 Axle	1
5R-2	88-140-16	Hex Head Cap Screw 1/2 N.C. x 2	4
5R-3	41-712-00	Differential Gear Case Assembly, for Small 1.628 I.D. Carrier Bearing	1
5R-3	41-713-00	Differential Gear Case Assembly, for Large 1.784 I.D. Carrier Bearing	1
5R-4	41-703-00	Differential Shaft Pinion Kit of Two Gears and Two Thrust Washers, F2 Axle	1 Kit
5R-5	41-702-00	Differential Pinion Shaft Thrust Washer, F2	2
5R-6	41-704-00	Differential Side Gear Thrust Washer, F2	2
5R-7	41-705-00	Differential Side Gear Kit of Two Differential Gears and Two Thrust Washers	1 Kit
5R-8	80-127-00	Tapered Bearing Race, Small, F2 Axle Timken LM 501310	2
5R-8	80-128-00	Tapered Bearing Race, Large, F2 Axle Timken LM 603011	2
5R-9	80-511-00	Tapered Roller Bearing, Carrier (Small 1.628 I.D.)	2
5R-9	80-512-00	Tapered Roller Bearing, Carrier (Large 1.784 I.D.)	2
5R-10	96-243-00	Hex Head Cap Screw 7/16 N.F. x 7/8, Grade 5	10
5R-11	97-163-00	Washer, 7/16 I.D. x 3/4 O.D. x 1/32 Thick	10
5R-12	41-707-00	Differential Bearing Adjustment Nut 3-1/8 - 16 with small 1.628 I.D. Carrier Bearing, F2 Axle	2
5R-12	41-708-00	Differential Bearing Adjustment Nut 3-5/16 - 16 with Large 1.784 I.D. Carrier Bearing, F2 Axle	2
5R-13	41-706-00	Differential Bearing Adjustment Nut Lock, F2 Axle	2
5R-14	88-080-04	Hex Head Cap Screw 5/16 N.C. x 3/8	2
5R-15	41-701-00	Pin	1
5R-16	41-700-00	Differential Pinion Shaft	1
5R-17	31-235-00	Ring & Pinion Gear Set, 2.75 Gear Ratio	1
5R-17	31-236-00	Ring & Pinion Gear Set, 3.10 Gear Ratio	1
5R-17	31-237-00	Ring & Pinion Gear Set, 3.25 Gear Ratio	1
5R-17	31-238-00	Ring & Pinion Gear Set, 3.50 Gear Ratio	1
5R-17	31-239-00	Ring & Pinion Gear Set, 5.43 Gear Ratio	1
5R-17	31-234-00	Ring & Pinion Gear Set, 3.00 Gear Ratio	1

FIG. I.D. NO.	T-D PART NO.	DESCRITPION	QTY. REQ.
5R-18	41-711-00	Shim Drive Pinion Bearing .005" Thick F2	1-3
5R-19	80-702-00	O-Ring Differential Drive, National 623025, 4-3/4 I.D. x 5 O.D.	1
5R-20	80-555-00	Roller Bearing, Pinion, Rear, F2 Axle	1
5R-21	41-714-00	Driving Pinion Pilot Bearing Retainer	1
5R-22	80-554-00	Tapered Roller Bearing, Pinion Shaft	2
5R-23	44-340-91	Pinion Bearing Housing with Bearing Races	1
5R-24	80-125-00	Tapered Bearing Race	2
5R-25	16-415-00	Spacer Pinion Bearing .440 Thick	1
5R-26	16-410-00	Spacer Pinion Shaft, .020 Thick, 1-5/16 I.D. x 1-5/8 O.D.	1-3
5R-26	16-419-00	Spacer Pinion Shaft, .002 Thick, 1-5/16 I.D. x 1-5/8 O.D.	1-3
5R-27	16-411-00	Spacer Pinion Shaft, .005 Thick, 1-5/16 I.D. x 1-5/8 O.D.	1-3

MAINTENANCE PROCEDURES

MECHANICAL CONTROL LINKAGE

REFER TO FIGURE 7

The mechanical control linkage operates the various controls and mechanisms located throughout your vehicle.

The accelerator system consists of the operating pedal and pivot shaft assembly, the connecting rods and adjusters and the return spring. All wear points should be lubricated monthly for normal service. Refer to Maintenance Guide Section D and Lubrication Diagram Section E for proper application of lubricants.

The footbrake system consists of the foot pedal, pivot shaft, connecting link, brake operating cable, and return spring.

All wear points should be lubricated monthly. Refer to Maintenance Guide Section D and Lubrication Diagram Section E for proper application of lubricants.

For service and adjustments refer to the following sections;

Section J2B - For brake service and adjustments.

Section J6 - For accelerator service and adjustments.

SEE FIGURE 9

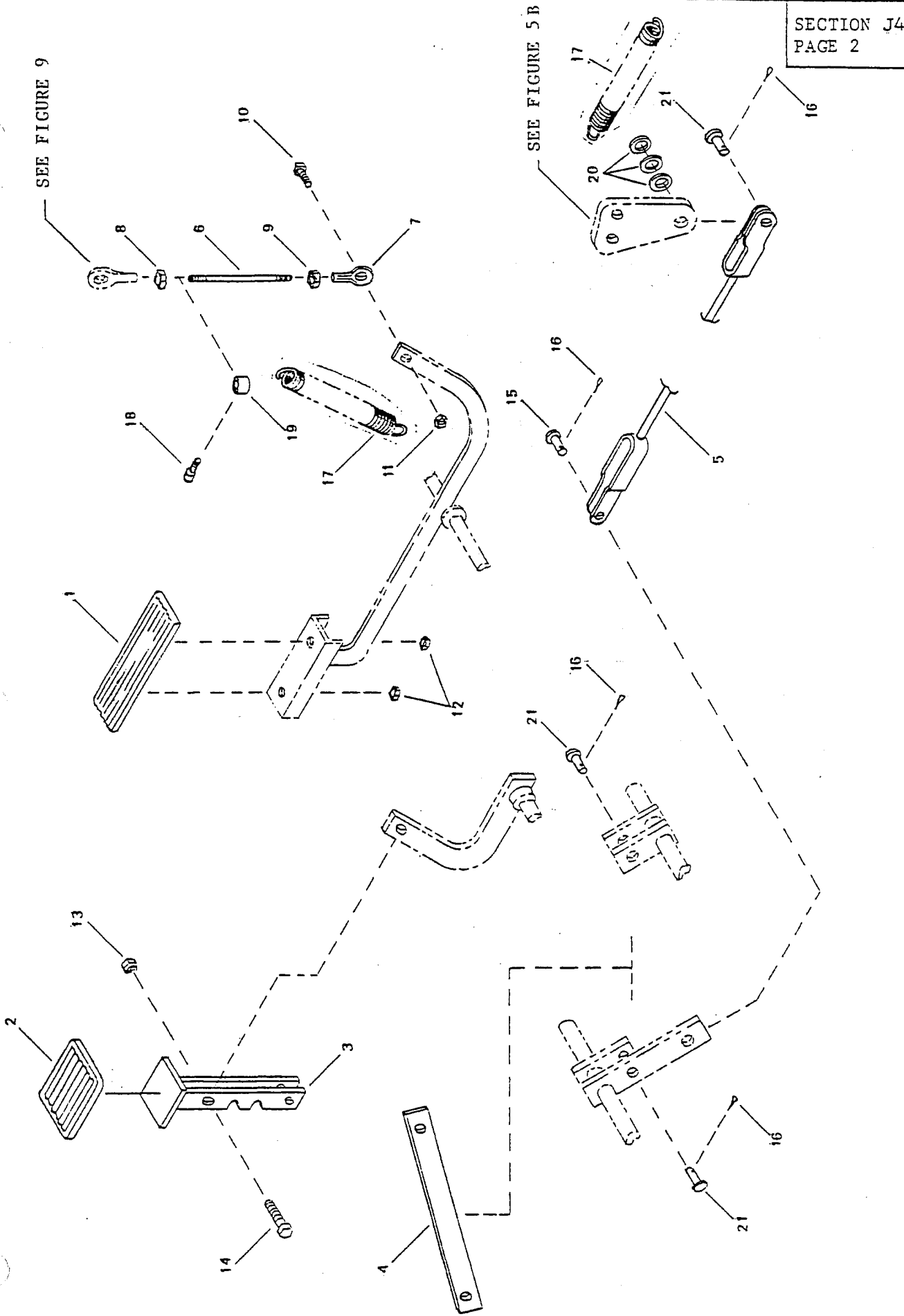

SEE FIGURE 5 B

LENGTH | QUAN. | REVISED DATE | REVISION

TAYLOR DUNN MFG. CO
2114 West Ball Rd.
Anaheim, Calif.

CONTROL LINKAGE
MODEL 2534 SS

FIGURE 7
SECTION J4

SECTION J4
PAGE 2

NO.	DESCRIPTION
TOL. FRAC. +	DEC. -
SCALE	NONE
DRAWN BY	EDE
DATE	2-13-76

MECHANICAL CONTROL LINKAGEREFER TO FIGURE 7

FIG. I.D. NO.	T-D PART NO.	DESCRIPTION	QTY. REQ.
7-1	98-254-00	Accelerator Pad (Aluminum)	1
7-2	98-200-00	Brake Pedal Pad	1
7-3	51-508-00	Pedal, Brake, & Lock	1
7-4	50-432-00	Link, Brake Pedal Connecting	1
7-5	96-813-00	Brake Cable Assembly 28-1/4 to 31-1/4 Length	1
7-6	50-003-00	Rod, Accelerator Adjustment	1
7-7	86-503-98	Rod End, Spherical Bearing - Left hand thread	1
7-8	88-079-80	1/4-28 N.F. Hex Nut	1
7-9	97-211-00	Nut, 1/4 N.F. - Left Hand Thread	1
7-10	88-060-11	1/4 N.C. x 1 Hex Head Cap Screw	1
7-11	88-069-81	1/4 N.C. Hex Lock Nut	1
7-12	88-069-87	Nut, 1/4 N.C., Fastite	2
7-13	88-149-81	1/2 N.C. Hex Lock Nut	1
7-14	88-140-14	1/2 N.C. x 1-1/2, Hex Head Cap Screw	1
7-15	96-771-00	Clevis Pin, 3/8 x 3/4 Face to Hole	1
7-16	88-517-11	Cotter Pin, 3/32 x 1	4
7-17	85-295-00	Spring Extension 9/16 O.D. x 4-7/8	2
7-18	88-047-06	10-32 x 1/2 Socket Head Cap Screw	1
7-19	17-100-00	Collar, 1/4" Shaft	1
7-20	88-108-60	3/8 Washer	3
7-21	96-772-00	Clevis Pin, 3/8 x 1 Fact to Hole	3

MAINTENANCE PROCEDURES
MASTER CONTROL SWITCH
REFER TO FIGURE 9

GENERAL

CAUTION: Before working on the Master Control Switch or any part of the vehicle electrical system, disconnect both main positive & negative battery leads, place the forward/reverse switch in NEUTRAL, turn key off and remove from switch. Set Parking Brake.

The Master Control Switch supplied with your vehicle controls both direction and speed of travel. It is located below the deck board and is readily accessible for routing maintenance. The switching components are rugged, designed for long life and trouble free operation. Maintenance requirements are simple and easy to perform. Adherence to a regular schedule will assure maximum life of, and minimum trouble with the system.

It is recommended that all terminal connections be checked and tightened at least once a month. If a terminal bolt or wire comes loose, sufficient heat will be generated to cause permanent damage at the connection. Disconnect battery leads while servicing to prevent unintentional vehicle movement.

A NOTE OF CAUTION: The nuts on the Forward-Reverse Rotor contact buttons are for holding the wire terminals only. They should not lock the buttons to the boards. The buttons must be free to rotate, or else the wires will eventually break at the terminals.

All occasional application of powered graphite, or similar key lock lubricant will keep your key and lock in good order.

Refer to Section D and E for recommended scheduling of routine maintenance and for lubrication instructions.

Refer to Service and Adjustment instructions of this section of the manual for replacement and adjustment procedures.

FORWARD/REVERSE SWITCH

The forward/reverse portion of the master switch is operated by the hand lever which projects into the passenger compartment. This part of the system determines the direction of current flow through the motor armature. IT SHOULD NOT BE OPERATED WHILE THE VEHICLE IS IN MOTION. This seriously reduces the life of the switch through arcking, and will place excessive strain on the motor, and on other components in the power train.

A light coating of grease should be maintained on the contact buttons, and firm, but not binding, pressure of contact buttons to power bars should be maintained.

SPEED CONTROL SWITCH

The Speed Control portion of the Master Switch is operated by the accelerator pedal and linkage. Voltage applied to the motor is varied by the use of resistance wire, mounted rearward of the switch, and by varying the number of batteries applied to the motor circuit. A light coating of grease MUST be maintained on the power bars where there is contact with the contact buttons, and periodic cleaning is essential to prevent short circuits and assure proper operation.

Clean off all dirt & grease on and between the power bars and contact buttons with a suitable rag, or plastic probe, or steam clean, or with an electrically non-conductive object. The important thing to remember is NOT TO USE any object, for switch cleaning or lubing purposes, that contains metal or is metal coated.

SERVICE AND ADJUSTMENT

MASTER CONTROL SWITCH
REFER TO FIGURE 9

CAUTION: Whenever service work is to be performed on the electrical system, disconnect the two main positive & negative battery jumpers to prevent accidental engagement of power while servicing switch.

ADJUSTMENT OF SPEED CONTROL LINKAGE (Refer to Diagram A)

1. Place Forward/Reverse switch knob at OFF position. Lock and remove key.
2. Depress accelerator pedal until it contacts floor board, and note position of speed rotor contact button and speed rotor. Button should be in full contact with high speed power bar, with a minimum of 1/32 inch clearance between rotor and nut on lower screw of high speed power bar.
3. If contact button is not in proper position, disengage accelerator return spring from accelerator rod, and loosen nuts on rod which bear against ball joint rod ends. NOTE: Threads at lower end of rod are left-hand threads.
4. Turn rod to change effective length. Lengthening the rod will move the button toward the third speed bar, while shortening it will move it toward the second speed bar.
5. When proper adjustment has been made, tighten locking nuts on rod against ball joint ends, and re-engage accelerator return spring.
6. With accelerator pedal released, contact button must be in full contact with steel neutral bar. This will automatically occur when high speed position is properly adjusted, unless the accelerator pedal extension bar has been bent out of position. Should this have occurred, it will be necessary to bend the pedal extension bar into position and repeat the adjustment outlined above.

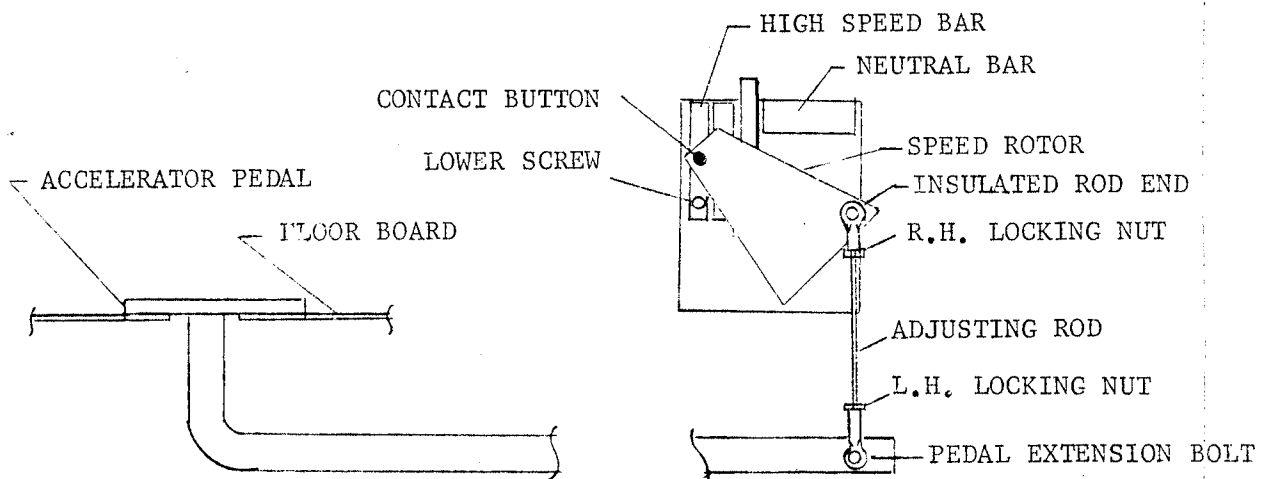

DIAGRAM A

REMOVE AND REPLACE MASTER SWITCH

1. Disconnect the two outer jumpers which connect the front and rear batteries.
2. Disengage accelerator return spring.
3. Remove pedal extension bolt and nut (See Diagram A).
4. Unscrew knob from Forward/Reverse handle.
5. Remove two switch mounting screws at bottom of mounting board.
6. Note locations of wires connected to switch and mark accordingly to assure their return to correct locations and disconnect from switch.
7. For Service of Adjustments refer to other Subsections of this Section of manual.
8. Replace Switch in reverse order of removal. Before connecting battery leads, adjust speed control linkage as outlined in preceding Subsection, and lubricate rotor contact path.

REPLACE SPEED ROTOR CONTACT BUTTONS

1. Disconnect the two outer jumpers which connect the front and rear batteries.
2. Disengage accelerator return spring.
3. Loosen nuts which lock accelerator rod to ball joint rod ends, and disengage rod from rod end fastened to speed rotor.
4. Remove nut which retains rotor spring, and remove spring and rotor.
5. Install new contact buttons, check operation against power bars for smoothness, and dress any rough points on buttons or power bars.
6. Reassemble rotor to switch in reverse order of removal. Before connecting battery leads, adjust rotor spring pressure and Speed Control Linkage as described in appropriate Subsections of this Section of Manual, and lubricate rotor contact path.

REPLACE FORWARD/REVERSE CONTACT BUTTONS

1. Follow Steps 1 through 6 in Subsection titled "Remove and Replace Master Control Switch".
2. Remove nut which retains Forward/Reverse rotor spring, remove spring and rotor from switch.
3. Install new contact buttons. Do Not lock contact button to rotor board when installing nut. Contact buttons must be free to rotate, or else wire breakage will eventually occur. Spring pressure will hold the contact buttons in place.
4. Install rotor to switch, and check clearance between rotor board and the screws which retain the power bars to mounting board. If clearance is less than 1/32 inch it will be necessary to replace the power bars. Refer to appropriate subsection.
5. Check operation for smoothness, and dress any rough points on contact buttons or power bars.
6. Lubricate path of contact buttons with a light coating of grease.
7. Reassemble switch to vehicle in reverse order of removal. Before connecting battery leads, adjust speed control linkage as described in appropriate Subsection of this Section of Manual.

ADJUSTMENT OF ROTOR SPRINGS

Firm, but not binding, pressure must be maintained between the contact buttons and power bars. The rate of wear of these components in normal use is very slight, and frequent adjustment is not necessary. Proper pressure settings are as follows:

1. Forward/Reverse - Compress 1-1/2" spring to 1-1/4 to 1-1/8.
2. Speed Control - Compress 2" spring to 1-1/2 to 1-3/8.

REPLACE POWER BARS

NOTE: Power bars tend to wear at the same rate, except when one bar may become excessively burned because of poor contact. When replacing with new power bars, it is important that all bars be of the same thickness. Binding and sticking will occur when bars are not of uniform thickness. For this reason, it is recommended that power bars associated with either the forward/reverse rotor or speed contact rotor be replaced as a full set.

1. Follow steps 1 through 6 in Subsection titled "Remove and Replace Master Control Switch".
2. Remove holding screws or nuts from power bars and slide power bars from switch.
3. Clean switch thoroughly and install new power bars.

NOTE: The speed control power bars are retained by hex head screws in countersunk holes beneath the lower power bar on the forward/reverse side. These screw heads must be insulated from the forward/reverse power bar. A non-conducting sealer, such as "Permatex", is satisfactory. In addition, the flat head screw next to the high speed power bar must be clear of the high speed power bar.

4. Check operation for smoothness, and dress any rough points on contact buttons or power bars.
5. Lubricate the paths of the contact buttons with a light coating of grease, and reassemble to console and vehicle in reverse order of removal. Before connecting battery leads, adjust Speed Control Linkage as described in Subsection of this Section of Manual.

INSTALLATION OF UPPER ROD END AND INSULATORS TO SPEED ROTOR

It is essential that rod end be fully insulated from speed rotor. The following assembly sequence will assure proper insulation. Refer to Figure 9.

1. Place one fiber insulating washer (45) on screw (16).
2. Place plastic bushing (46) on screw.
3. Install screw, washer and bushing to rotor (7).
4. Install plastic washer (49) over bushing.
5. Place second fiber washer (45) on screw.
6. Place metal washer (20) on screw.
7. Place rod end (44) on screw.
8. Install lock nut (22) to screw and tighten.

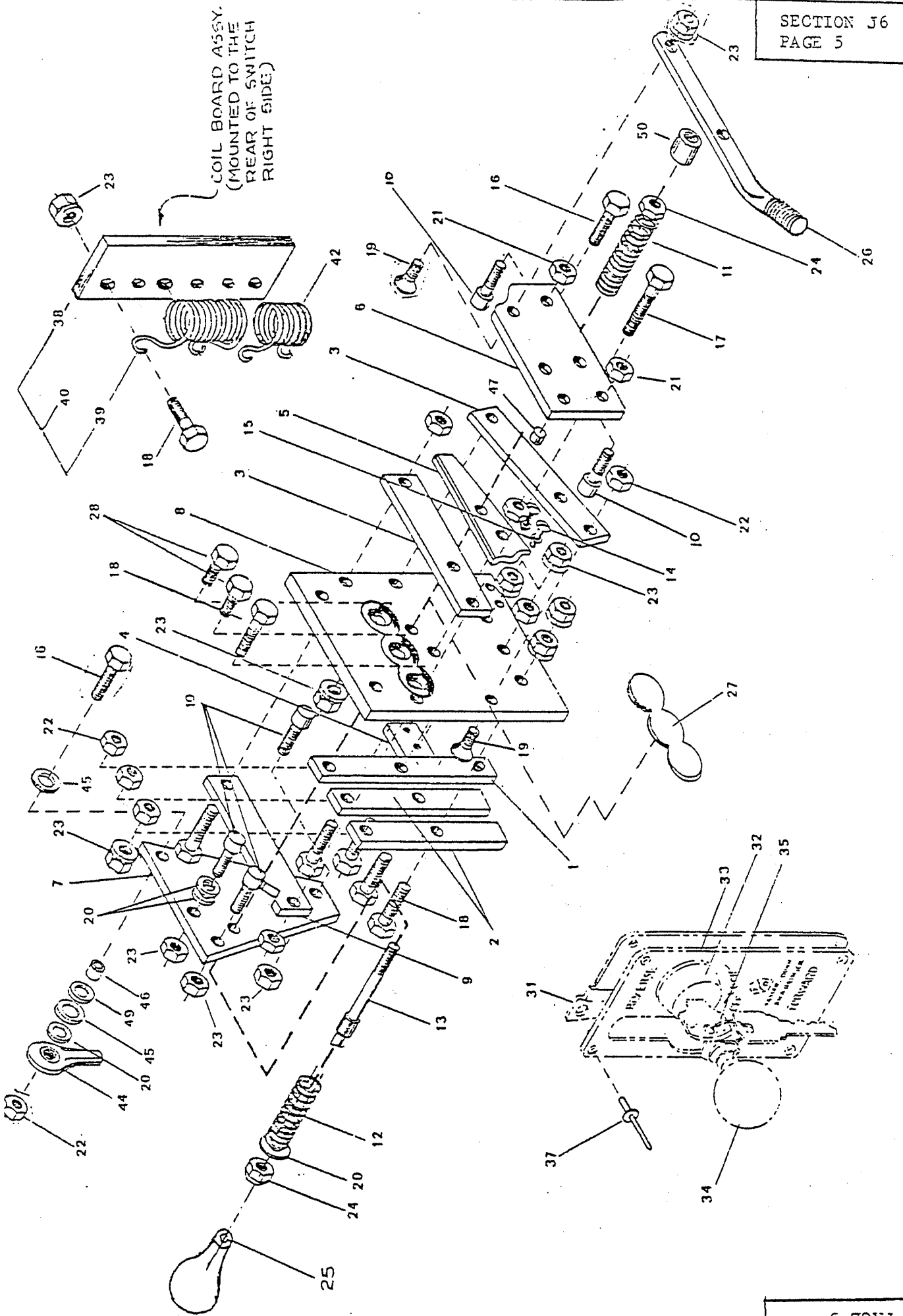

TAYLOR DUNN MFG. CO.
2114 West Ball Rd.
Anaheim, Calif.

REVISION 1-22-82
LENGTH QUAN. 12-8-81
MASTER CONTROL SWITCH &
RESISTOR THREE SPEED
2534 S

FIGURE 9
SECTION J6

SECTION J6
PAGE 5

NO.	DESCRIPTION
TOL. FRAC. ±	DEC. ±
SCALE	NONE
DRAWN BY	FDL
DATE	11-13-74

SPEED CONTROL & MAIN POWER SWITCHING
THREE SPEED SWITCHREFER TO FIGURE 9

FIG. I.D. NO.	T-D PART NO.	DESCRIPTION	QTY. REQ.
9-1	61-844-52	Power Bar - 3 Hole	1
9-2	61-844-51	Power Bar - 2 Hole	2
9-3	61-831-00	Power Bar	2
9-4	61-835-12	Neutral Bar	1
9-5	61-842-51	Neutral Board Forward/Reverse Switch	1
9-6	61-844-53	Rotor Board Forward/Reverse Switch	1
9-7	61-844-54	Rotor Board Speed Control Switch	1
9-8	61-844-00	Master Control Switch Board	1
9-9	61-831-52	Power Bar - Steel	1
9-10	71-030-58	Contact Button	5
9-11	85-033-00	Spring 7/16 O.D. x 1-1/2 Long	1
9-12	85-034-00	Spring 7/16 O.D. x 2 Long	1
9-13	96-340-00	Pivot Stud (Double End)	1
9-14	88-026-11	8-32 x 1 Flat Head Machine Screw	2
9-15	88-028-62	#8 Lock Washer	2
9-16	88-060-11	1/4 x 1 N.C. Hex Head Cap Screw	5
9-17	88-060-12	1/4 x 1-1/8 N.C. Hex Head Cap Screw	3
9-18	88-060-13	1/4 x 1-1/4 N.C. Hex Head Cap Screw	4
9-19	88-066-09	1/4 x 3/4 N.C. Flat Head Machine Screw	1
9-20	88-068-61	1/4 SAE Washer	9
9-21	88-069-80	1/4 N.C. Hex Nut	3
9-22	88-069-81	1/4 N.C. Lock Nut	7
9-23	88-069-87	1/4 N.C. Fastite Nut	10
9-24	88-079-86	1/4 - 28 Locknut (Nylon Insert)	2
9-25	98-619-00	Bumper, Rubber Insulating	1
9-26	61-841-00	Handle, Forward/Reverse Switch (Cad. Plated)	1
9-27	61-844-55	Insulator	1
9-28	88-060-09	1/4 x 3/4 N.C. Hex Head Screw	2
* 9-31	97-314-10	Lock Plate Assembly with Lick & Key	1
* 9-32	71-040-55	Lock Assembly with Two Keys	1
* 9-33	94-307-00	Forward/Reverse Switch Plate	1
* 9-34	95-907-00	Knob - 1-1/4 Diameter	1
* 9-35	71-040-74	Key Only, Give Lock Number on Vehicle	2
* 9-37	88-737-08	Aluminum Rivet - 3/16 Diameter x 5/8 Long	4
* 9-38	78-225-00	Coil Board	1
* 9-39	78-212-52	Resistor Coil, #6 Wire, 9 Turns	1

NOTE: ITEMS MARKED (*) ARE NOT SUPPLIED AS PART OF 61-844-16 MASTER CONTROL SWITCH ASSEMBLY AND MUST BE ORDERED SEPERATELY.

FIG. I.D. NO.	T-D PART NO.	DESCRIPTION	QTY. REQ.
* 9-40	78-225-11	Coil Board & Resistor Coil Assembly	1
* 9-42	78-212-60	Resistor Coil, #9 Wire, 3 Turns	1
9-44	86-503-99	Rod End, Spherical Bearing Right Hand Thread	1
9-45	97-170-00	Washer, Insulated 3/4 Inch O.D.	2
9-46	32-212-50	Plastic Bushing 1/4 x 1/4	1
9-47	61-846-51	Stabilizer Button, Forward/Reverse Switch	1
9-49	97-169-00	Washer, Nylatron, 3/8 I.D.	1
* 9-50	98-619-00	Insulator	1
	61-844-16	Master Control Switch - Three Speed (Includes All Items not Marked (*))	1

NOTE: ITEMS MARKED (*) ARE NOT SUPPLIED AS PART OF 61-844-16 MASTER CONTROL SWITCH ASSEMBLY AND MUST BE ORDERED SEPERATELY.

MAINTENANCE PROCEDURES
GENERAL ELECTRIC SYSTEM

Your electrical system has been installed with care, utilizing quality materials for safe trouble free service. Proper fuses have been located where necessary to prevent unsafe overloads and protect the wiring from being damaged from short circuits.

Little care will be required, except for an occasional visual inspection for loose connections or some unusual condition causing the insulation to be rubbed off on a wire.

Normal replacement parts such as light bulbs, fuses, flasher etc. have been arranged for simple changing by plug in devices or conveniently located terminals.

CAUTION: A blown fuse is usually indicative of a short circuit or faulty device. Care should be exercised to remove the faulty condition before replacing fuse. DO NOT place larger capacity fuses or "jumpers" to overcome the condition as serious wiring damage can occur.

CAUTION: Whenever service work is to be performed on any part of the vehicles electrical system, disconnect the two main positive & negative battery leads to prevent accidental engagement of power.

Refer to the following sections for more detailed information on the main power and electrical components:

Section G - Wiring Diagram

Section J2 - Motor

Section J6 - Speed Control and Main Power Switching

Section J8 - Batteries and Charger.

GENERAL ELECTRICAL PARTS

T-D PART NO.	DESCRIPTION	QTY. REQ.
71-100-00	Light Switch	1
71-111-00	Brake Light Switch	1
71-135-00	Micro Switch	1
71-505-00	Bracket - Horn Button, Light Switch And Headlight With Geared Steering	1
71-502-00	Horn Button	1
72-005-00	Chrome Headlight Fixture With 4" Sealed Beam Bulb	1
72-022-00	Stop And Taillight Fixture, 4" Rubber Mount (12 Volt)	2
72-072-00	4" Sealed Beam Headlight Bulb (12 Volt)	1
73-004-00	Horn (12 Volt)	1
74-000-00	Hour Meter	1
74-005-00	Charge Indicator (12 Volt)	1
75-010-00	Wiring Harness For Power, Lights And Horn	1
75-206-00	Wire #6 (Per Foot)	
75-208-00	Wire #8 (Per Foot)	
75-218-00	Wire #16 (Per Foot)	
75-231-00	Battery Jumper #6 Wire (10-1/4" Long)	
75-406-53	Terminal Lug #6 Wire 1/4" Hole	
75-406-54	Terminal Lug #6 Wire 5/16" Hole	
75-408-54	Terminal Lug #8 Wire 5/16" Hole	
75-408-53	Terminal Lug #8 Wire 1/4" Hole	
75-418-51	Terminal Lug #16 Wire #6 Hole	
75-418-52	Terminal Lug #16 Wire 3/16" Hole	
75-418-53	Terminal Lug #16 Wire 1/4" Hole	
78-010-00	Secondary Fuse And Holder (Inline Type)	

MAINTENANCE PROCEDURES.
BATTERIES

WARNING: Lead acid batteries continuously emit highly explosive gases. Flame or sparks must be kept away from the batteries at all times.

This emission is greatly increased during the charging process. Any area in which charging batteries are confined must be well ventilated, and flame or sparks must be kept out of the charging area and away from ventilator openings. DO NOT disturb battery connections while batteries are being charged.

The lead acid battery (or batteries) will furnish all power required by your vehicle. Two types are generally employed. The electric vehicle type battery pack, commonly used, can be expected to have a life of approximately 2 years, or 350 to 400 cycles. One cycle is the discharging and charging of the battery within proper limits. The heavy duty industrial type of battery has a life of approximately 7½ years, or 1800 cycles, with appropriate use and care.

It cannot be over emphasized how important good maintenance procedures and careful care of your batteries will affect their useful life. It is therefore recommended that a comprehensive maintenance program be established and adhered to throughout the life of your vehicle. A 5 point program is outlined below to assist you in understanding and establishing good battery care.

1. CORRECT CHARGING

Poor charging practices are responsible for more short battery life than any one other item. The charging equipment must be properly maintained and adjusted to give a charge which the battery will accept with maximum efficiency. Two things are involved in correct charging. These are the charging rate in amperes and the termination of the charge at the correct time. No amount of overcharging will increase the battery capacity or raise the specific gravity above its full charged condition.

Overcharging will reduce battery life. Undercharging will cause poor vehicle performance, and shorten the life of all electrical components, including the batteries. Refer to Service and Adjustment, Section J8, for proper methods to determine charge condition.

2. DISCHARGING - CAPACITY

Batteries are commonly rated in ampere hours at the six hour discharge rate to a final voltage of 1.75 per cell. They will deliver additional capacity in an emergency, but should not be required to do so regularly. The best way to avoid discharging is to prepare a rigid schedule for charging batteries which will insure against their being discharged beyond the limits of their capability.

3. WATERING

Water must be replaced from time to time. The frequency and quantity depends upon the watering space above the plates and the amount of gassing which the battery does on charge. Only approved or distilled water should be added to the battery. Water should be added after hydrometer or voltmeter readings have been taken. The liquid level within the battery raises as the gassing occurs. Thus filling after charging minimizes over-filling. However, the water level should cover the plates prior to charging.

MAINTENANCE PROCEDURES
BATTERIES

4. CLEANING

Batteries pick up various kinds of dirt and dust, depending on their surroundings and the type of service they are subject to. This is usually dry dirt, which can readily be blown off with low pressure air or brushed off. However, if cells are overfilled and electrolyte collects on the covers, the top of the battery becomes wet and stays wet, since the acid in the electrolyte does not evaporate. This moist surface in combination with certain kinds of dirt becomes electrically conductive and permits stray currents to flow externally over the top of the battery. These currents cause corrosion of cell posts, nuts, connectors and steel trays, which eventually become troublesome and expensive to repair.

When wet dirt accumulates on top of the battery, remove it by washing the battery with a strong solution of baking soda and hot water (1 lb. of soda to 1/2 gallon of water). A convenient brush to use is one having flexible bristles like an old paint brush. Continue the application of the soda solution until all fizzing stops, which indicates that the acid has been neutralized. Then rinse thoroughly with clear water.

Wet covers can be indication of overfilling, leaky seals at posts and covers or of excessive gassing during charge. When observed the cause should be determined and the abusive conditions corrected.

5. RECORDS

A battery record system is recommended for all vehicles. It is considered essential for large operations, and where minimum battery operating cost is desired. A properly supervised record system can be made to detect and call attention to such operating irregularities as:

- a. Overcharging
- b. Undercharging
- c. Overdischarging
- d. Excessive Water Consumption
- e. Cleanliness
- f. Worn out Batteries
- g. Excessive Current Consumption on Trucks

It is not advisable to allow a battery to stand for a long period of time in a low state of charge. Doing so subjects the battery to excessive plate erosion and in cold climate conditions the electrolyte will freeze at a much higher temperature. For example, a fully charged battery will not freeze at temperatures near 60° below zero. Yet a battery in a very low state of charge may freeze at temperatures around 10° to 15° above zero.

A battery not in use maintains small amounts of chemical action which slowly tends to dissipate the charged condition. It is wise to re-charge a battery not in use every 1 to 2 months. If possible store the battery in a cool place, as the self discharge rate is increased with warmer temperatures.

VEHICLE NO.

MBATTERY MAINTENANCE RECORD

Battery No.	Cell No.	Date		Date		Date		Date		Date			
		Water OK or Low	Gravity Before Charge	Gravity After Charge	Water OK or Low	Gravity Before Charge	Gravity After Charge	Water OK or Low	Gravity Before Charge	Gravity After Charge	Water OK or Low	Gravity Before Charge	Gravity After Charge
1	1												
	2												
	3												
2	1												
	2												
	3												
3	1												
	2												
	3												
4	1												
	2												
	3												
5	1												
	2												
	3												
6	1												
	2												
	3												

- CAUTION: Batteries emit explosive gases. During normal operation the concentration of these gases is rarely sufficient to be considered dangerous unless flame or sparks occur in the battery compartment close to the vent holes in the battery caps. It is important that this not be allowed to occur at anytime. During the charging process, emissions are greatly increased. Any area in which charging batteries are confined must be well ventilated, and flame, sparks, or lighted cigarettes must be kept out of the charging area and away from ventilator openings associated with the charging area. Battery connections must not be disturbed while batteries are being charged.
- Do not fill an uncharged battery. Bring water level up to just cover the plates, and complete filling after battery is fully charged. Use distilled water. Fill only to level indicated on battery.
- Batteries which require unusually frequent watering may indicate overcharging. Review charging practices and/or adjustment of transformer taps in charger.
- Gravity should be kept between 1175 (30% charged) and 1260 (100% charged), and gravity readings of all cells should be within 10 point range. When they are not, an equalizing charge should be applied. Refer to information under "Charging Time Chart" in Charger Handbook.
- Periodically check for loose terminal posts or loose connections to terminal posts, but not while batteries are being charged.
- Keep tops of batteries clean, and free of moisture, grease, and acid films. Any of these can cause current leakage.
- Keep weekly (or oftener) record as shown in above sample chart, for a new vehicle or when charging results seem unsatisfactory, until satisfactory charging continues for a four week period, then keep record on a monthly basis.

BATTERIES

T-D PART NO.	DESCRIPTION	QTY. REQ.
SEE PARTS LIST IN CHARGER MANUAL		
75-231-00	Battery Jumper #6 Wire (10-1/4" Long)	3
75-240-00	Battery Box Charging Cord and Plug	1
75-241-00	Battery Box Charging Receptacle	1
76-999-00	6 Volt - 110 A.H. Battery	4
77-031-00	6 Volt, 190 A.H. Battery	4
77-042-00	6 Volt, 217 A.H. Battery	4
77-200-00	Hydrometer	1
77-201-00	Battery Filler	1
79-227-00	Charger, 24 Volt, 25 AMP, Line Comp. Built-In (2425 LB)	0 or 1
79-230-00	Charger, 24 Volt, 25 AMP, Line Comp. Portable (2425L)	0 or 1
79-227-55	Cabinet, Control, Built-In Charger, Line Compensating	1

NOTE: PAGES 5 THROUGH 15 INTENTIONALLY LEFT OUT

SERIES "L" BATTERY CHARGER
OPERATING AND SERVICING INSTRUCTIONS

INTRODUCTION

The Christie Series "L" battery Chargers are designed for safe and efficient daily recharging of electric vehicle batteries.

SPECIFICATIONS

<u>MODEL</u>	<u>A-C</u> <u>VOLTS</u>	<u>A-C</u> <u>AMP</u>	<u>BATTERY</u> <u>AMP HOURS</u>	<u>D-C</u> <u>VOLTS</u>	<u>D-C</u> <u>AMP</u>
2425L	115	7	130 - 220	24	25
2425LB (Built-in)	115	7	130 - 220	24	25

CHARGING CHARACTERISTICS

This charger uses a modified constant potential method of recharging. The rate of charge will reduce as the battery voltage increases during recharging. On a discharged battery the charger should start charging at or near it's rated output and as the battery recharges the charge rate will be reduced until it reaches a final charge rate of approximately 3 to 5 amperes when the battery is fully charged. The ferroresonant circuitry used in this charger compensates for line voltage variations of $\pm 10\%$ from 115 Volts to provide a constant end charge voltage. This same circuitry also has a current limiting feature which prevents the charger from exceeding 120% of it's rated output under overload conditions. The charging time is controlled by a timer which terminates the charge at the end of the pre-set time.

INSTALLATION

The battery charger should be set on a suitable working surface so that there is access to the control panel. There must be at least six inches of clearance on each side and two inches on the top to allow free flow of air for cooling.

Do not expose the portable model to rain or other adverse weather conditions. There must be a separately fused, three-wire, single phase, 115 volt, 15 ampere power receptacle within reach of the A-C input cord of the charger.

OPERATING INSTRUCTIONS

1. Verify that the output fuses are fully tightened.
2. Verify that the timer knob is in the "OFF" position. The timer must be off to prevent sparking at the D-C plug when connecting to the D-C receptacle.
3. Connect the charging plug to the battery receptacle. Chargers are furnished with a polarized D-C charging plug that mates with a corresponding polarized receptacle in the vehicle to prevent improper connections to the battery. Built-in models are permanently connected to batteries.

OPERATING INSTRUCTIONS (Cont.)

4. Connect the A-C plug to a grounded A-C power outlet.
5. Turn the timer knob to the position marked "DAILY USE."
6. After turning the time "ON" to the desired setting verify that the charger is operating by observing that the meter indicates a charging current. If there is no charging current, see "TROUBLE SHOOTING" section.
7. The timer will turn the charger off after the pre-set time has elapsed. The approximate number of hours for each setting are indicated below. If the timer does not shut the charger off, see "TROUBLE SHOOTING" section.
8. After the recharge is completed and the timer has turned the charger off, remove the charging plug from the vehicle.
9. Using a hydrometer, verify that the battery is properly charged.

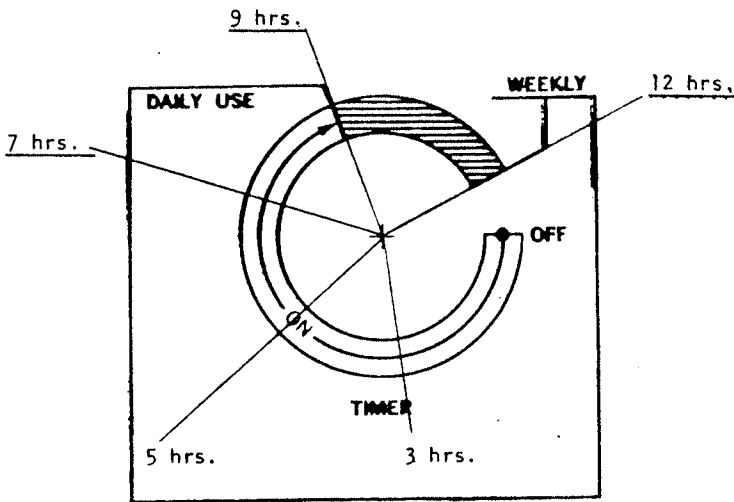

TIMER DIAL
(S/N A3940 and up)

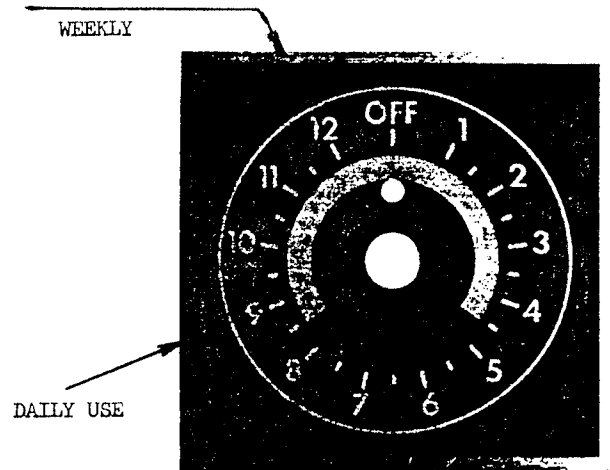

TIMER DIAL
(S/N A3939 and below including
all S/N's without "A" prefix)

NOTE: If batteries require water too frequently recharge for a shorter time. On consecutive days set the timer for two hours less, checking battery specific gravity after each recharge. When a setting is established that consistently brings batteries to 1250-1260 specific gravity with minimum recharge time it will be the correct time setting. If setting is less than 5 hours it may be more convenient to use "DAILY USE" setting every other day.

TROUBLE SHOOTING AND
REPAIR INSTRUCTIONS

LOW OR NO CHARGING CURRENT

1. Verify that the battery being charged has no open or dead cells. Check jumper cables between batteries for tight and clean connections, and also verify that the battery is not already fully charged.
2. Check the output fuses of the charger. Check internal A-C fuse on built-in chargers.
(NOTE: Built-in chargers below Serial Number A4230, including all serial numbers without "A" prefix, have same fuse arrangement as the portable model.)
3. Verify that the A-C receptacle has power by plugging in an electrical appliance.
4. Turn the charger ON and verify that the transformer hums. If no hum is heard, proceed with step 4.1.
 - 4.1 Remove the cabinet cover to gain access to the interior of the charger.
 - 4.2 On larger chargers furnished with a power relay (see wiring diagram) verify that the relay accuates when charger is turned on. If relay does not close, check continuity across relay coil. Also check for burned or damaged relay contacts.
 - 4.3 Disconnect the transformer primary leads from the timer assembly or power relay. Check for continuity between the primary input leads of the transformer. If no continuity is found, replace the transformer. If continuity is found, proceed as follows:
 - 4.4 With the timer switch ON, check for continuity across the switch. If the switch is open with the timer on, replace the timer assembly.
 - 4.5 If all of the foregoing checks indicate continuity but the transformer does not hum, check for loose or broken leads between the A-C plug, timer assembly, and the terminal board.
5. If the transformer hums, proceed as follows:
 - 5.1 Check the output fuses to insure they are good. Inspect the fuse holders for damage or a blackened appearance. (If the fuse holder is blackened it indicates oxidation and should be replaced).
 - 5.2 Remove the cabinet cover to gain access to the interior of the charger.
 - 5.3 Disconnect the capacitor or capacitors for the following test:
 - 5.4 Remove one of the output fuses. On built-in chargers remove the wires from transformer to one of the diodes. With the timer switch OFF, check for continuity across the D-C output, connecting the continuity indicator first in one direction and then in the other. The indicator should show an open in one direction and continuity in the other.
 - 5.5 Repeat step 5.4 interchanging the condition of the two output fuses. On built-in chargers reconnect wires removed in 5.4, disconnect wires from transformer to other diode and repeat check in 5.4.

- 5.6 If the indications obtained in steps 5.4 and 5.5 are normal, the secondary of the transformer is shorted and it should be replaced. If a short is measured in both directions in either step 5.4 or 5.5, the diode associated with the installed fuse is defective and should be replaced. If the indications in both directions in either step 5.4 or 5.5 are open, then the diode or transformer secondary may be open.
- 5.7 To check diodes, disconnect leads to each diode and measure continuity in both directions from diode terminal to heat sink. If either diode is open in both directions it should be replaced.
- 5.8 If diodes check O.K. with leads to diodes or fuse holder removed, check transformer secondary from center tap to (1) and center tap to (2) for continuity. If there is not continuity in either case, replace transformer.
- 5.9 Check for continuity across meter terminals. If continuity does not exist, replace meter.
- 5.10 If all indications to this point are normal, test the entire D-C output circuitry for continuity by progressing from the +D-C output terminal to the -D-C terminal in incremental test sections, checking for open circuits and poor connections.
- 5.11 Test the resonance transformer for continuity between test points (3) and (4). If open, replace transformer.
- 5.12 Test the resonance transformer under operating conditions by making the voltage measurements noted in the schematic diagram. Replace the transformer if these voltages are not normal.
- 5.13 Remove one lead from capacitor. Check across capacitor for continuity. If continuity exists, replace capacitor.

A-C LINE FUSES OR INTERNAL A-C FUSE ON BUILT IN MODELS BLOW

6. With unit unplugged and timer turned ON, check for continuity between each input prong of the A-C plug and the ground prong. If all indications are open, the transformer or timer is shorted. Operate the timer with the transformer disconnected to isolate the faulty item.

OUTPUT FUSES BLOW

7. Verify that the circuit under charge is not shorted by disconnecting the charger and operating it disconnected.
8. If fuses continue to blow, test the charger as per steps 5.1 through 5.13.

TIMER DOES NOT TURN UNIT OFF

9. Indicates that timer motor or switch is faulty. Replace timer assembly.

IMPORTANT FACTS ON BATTERIES AND CHARGERS

To determine whether or not a battery is properly charged, a measuring device known as a hydrometer is used. A hydrometer measures the specific gravity of a liquid and a battery hydrometer is graduated to measure the specific gravity of battery electrolyte. The electrolyte in your battery becomes heavier as it is charged, therefore, a higher specific gravity reading indicates a higher charge condition of your battery. The specific gravity reading will range from 1100 for a completely discharged battery, to 1260 for a fully charged battery. No amount of overcharging will raise the specific gravity above 1260 on the electric vehicle type of battery. Both overcharging and undercharging can cause a premature failure of a battery. Overcharging destroys the positive plates. Consistent undercharging causes a buckling of the plates.

Do not discard a good battery as being defective because its specific gravity does not show an increase immediately upon applying a charge. Many good batteries require a charging period as long as three hours before they show any increase in the specific gravity. Do not charge a battery if the electrolyte temperature could rise above 120 degrees F. This could damage both battery and charger. As a rule of thumb, the electrolyte temperature during normal charging will rise about 25 degrees above the temperature in the charging area.

Failure to keep the battery electrolyte to the proper level will result in crumbling (abnormal sulfation) of the plates and cause failure of the battery. Distilled water must be added to the battery regularly to make up for the loss due to evaporation. Prior to charging, the electrolyte level should cover the battery plates. Fill the battery to the proper level only after it has been fully charged.

WARNING - HAZARD OF EXPLOSIVE GAS MIXTURE

Batteries being charged or discharged will give off hydrogen gas. If this gas is concentrated it can cause an explosion. Concentrations of gas may remain for several hours if ventilation is not provided. DO NOT have any fire in the vicinity and do not tamper with circuits that might cause sparking while charging or discharging batteries.

INSPECTION OF BATTERIES AND ASSOCIATED CIRCUITS

An inspection of batteries and associated circuits is required to assure that the batteries are being properly charged. For this inspection we recommend the use of a hydrometer and a continuity tester.

1. Verify that all connections within the unit to be charged are clean and tight.
2. Check each battery for loose terminal posts.
3. Test for continuity between all battery terminals and the charging receptacle.
4. Verify that the top of each battery is free of moisture, grease and acid film, which may cause terminal corrosion and current leakage.
5. After the battery has been recharged, test each individual cell in each battery with hydrometer to verify that all specific gravity readings are within 10 points of each other.

6. Using the hydrometer, pull out acid from a cell and then vigorously expel the acid back into the cell to cause a violent stirring action. Immediately draw out another sample of acid and visually inspect it to see if it contains a brownish sediment (indicates positive plates are deteriorated).

7. When testing battery condition with hydrometer, always return electrolyte solution to the same cell from which it was removed. DO NOT MIX electrolyte from one cell to another.

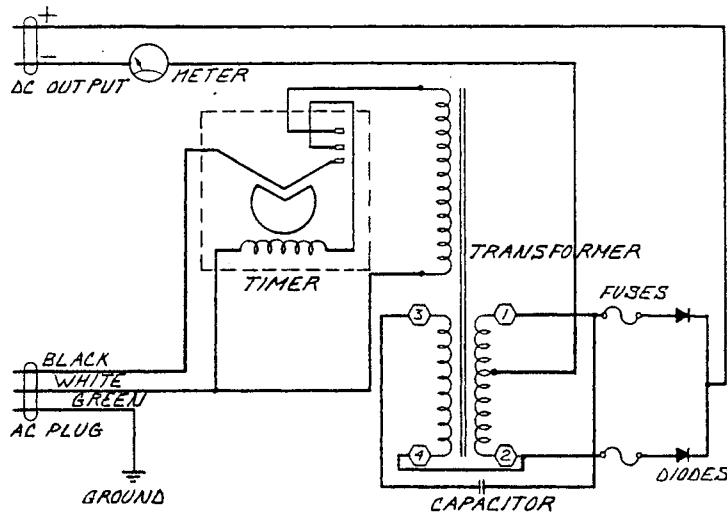

NOTES:

1. Schematic shows diagram for Timer manufactured by Mallory Timers and used on chargers manufactured after 4-1-76.
2. Component parts agree with exploded view and Parts List.

TEST VOLTAGES

Test Pts. 1 & 2 - 42VAC
Test Pts. 3 & 4 - 180VAC

NO.	DESCRIPTION	LENGTH	QUAN.	REVISED DATE	REVISION
TOL. FRAC. ±	DEC. ±				
SCALE				2425L	
DRAWN BY J.M.				PORTABLE CHARGER	
DATE 9-21-78					



TAYLOR DUNN MFG. CO.
2114 West Ball Rd.
Anaheim, Calif.

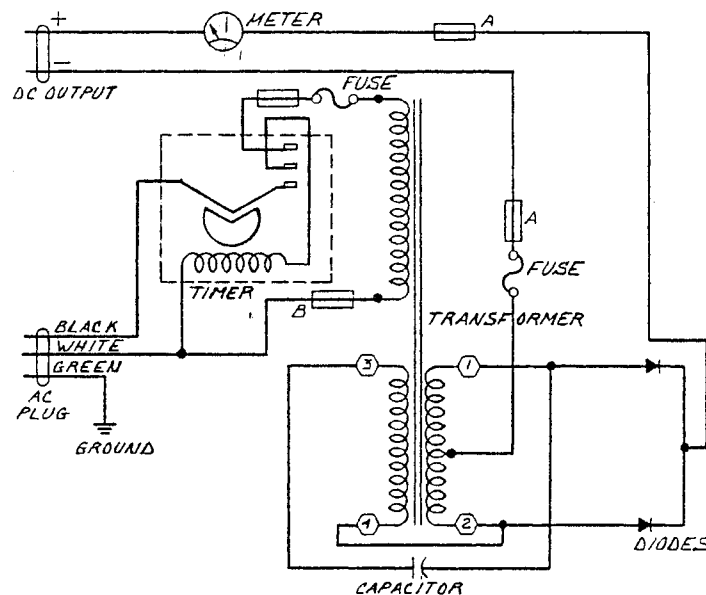

NOTES:

1. Indicates Knife Conn. between console and main cabinet. There are two sizes: "A" indicates large conn. and "B" indicates small.
2. Schematic shows diagram for timer manufactured by Mallory Timers and used on Chargers manufactured after 4-1-76
3. Component parts agree with exploded view and Parts List.

TEST VOLTAGES

Test Pts. 1 & 2 - 42VAC
Test Pts. 3 & 4 - 180VAC

NO.	DESCRIPTION	LENGTH	QUAN.	REVISED DATE	REVISION
TOL. FRAC. ±	DEC. ±				
SCALE				2425LB	
DRAWN BY J.M.				BUILT-IN CHARGER	
DATE 9-21-78					



TAYLOR DUNN MFG. CO.
2114 West Ball Rd.
Anaheim, Calif.

SERIES "L" CHARGER

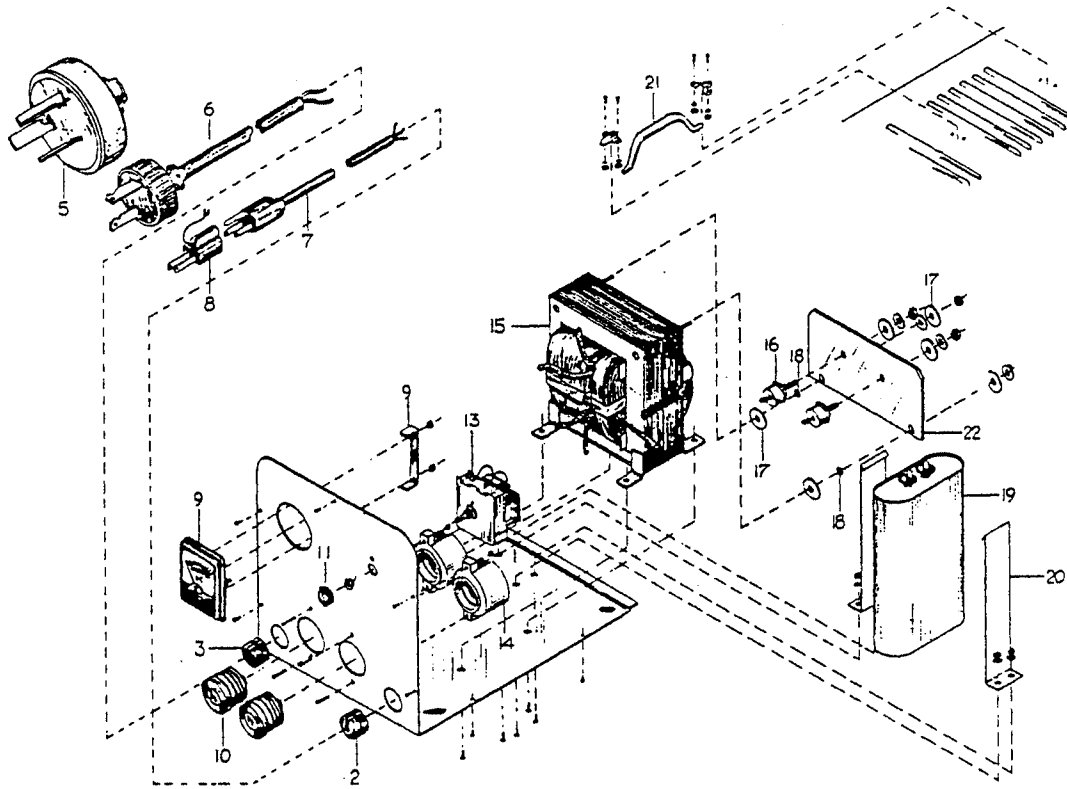

PARTS LIST

<u>ITEM</u>		<u>TAYLOR-DUNN PART NO.</u>
2	Bushing (A-C)	(HEYCO #6N3-4)
3	Bushing (D-C) Portable	(HEYCO #9P-1)
3A	Bushing, Built-In	(HEYCO #SB-500-6)
5	D-C Plug, 3-Prong (Portable)	76-002-00
6	Output Cord with Plug (Portable)	79-566-00
7	A-C Cord and Plug	79-570-00
9	Ammeter	79-851-00
10	Fuse, D-C (Portable & Built-In) S/N A4229 and Below	79-819-00
10A	Fuse Link, 40 AMP, D-C (Built-In) S/N A4230 and Up	79-825-10
10B	Fuse, 15 AMP Ceramic A-C (Built-In) S/N A4230 and Up	79-813-00
11	Timer Control Knob	79-803-00
13	Timer Assembly, 12-Hour	79-800-00
14	Fuse Holder Screw Type (Portable & Built-In) S/N A4229 and below	79-830-00
14A	Fuse Holder, A-C & D-C (Built-In) S/N A4230 and Up	79-515-00
15	Transformer, 24 Volt, 25 AMP Line Compensated	79-631-00
16	Diode, 45 AMP or less, (6-36 Volts)	79-720-00
17	Washer Assembly (3/4"), Insulated	97-170-00
18	Washer Assembly (3/8"), Insulated	97-171-00
19	Capacitor, Line Comp., Chargers	79-900-00
20	Bracket for Capacitor, Portable & Built-In, S/N A3485 & below	79-514-00
21	Handle Assembly (Portable)	79-509-00
22	Heat Sink	79-745-00

011134

CHARGER MAINTENANCE, SERVICE AND ADJUSTMENT

TAYLOR-DUNN / LESTER-MATIC
BATTERY CHARGER

Line voltage compensation achieved by flux oscillator circuit applied to battery chargers by Lester in 1962 for high reliability "Minute Man" missile standby applications. Compensates automatically for AC supply voltage variations 105-128 volts. Supply voltage variation $\pm 10\%$ from 117 volts = $\pm 1\%$ maximum battery voltage variation, decreasing to $\pm 1/2\%$ at finish rate with constant electrolyte temperature. No taps or rate controls to set.

Automatic taper of charge rate for superior battery life through good equalization of cells and low water use rate.

Silicon diodes with inherent surge protection operated at a conservative percentage of their rating.

Convection cooled design for maximum reliability and minimum maintenance.

LESTRONIC II BATTERY CHARGERS

The all new automatic Lestronic chargers eliminate over and undercharging for new, old or defective batteries, whether hot or cold. Precise charging is achieved by patented Electronic Timer, utilizing state of the art integrated circuits.

Charger turns on automatically by simply connecting D.C. cord to batteries. The ammeter indicates charge rate. The charge rate tapers gradually to a finish rate of 5 to 10 amps. The Electronic Timer monitors the rate of voltage change during the charge period. When this rate levels off, the charger automatically shuts off.

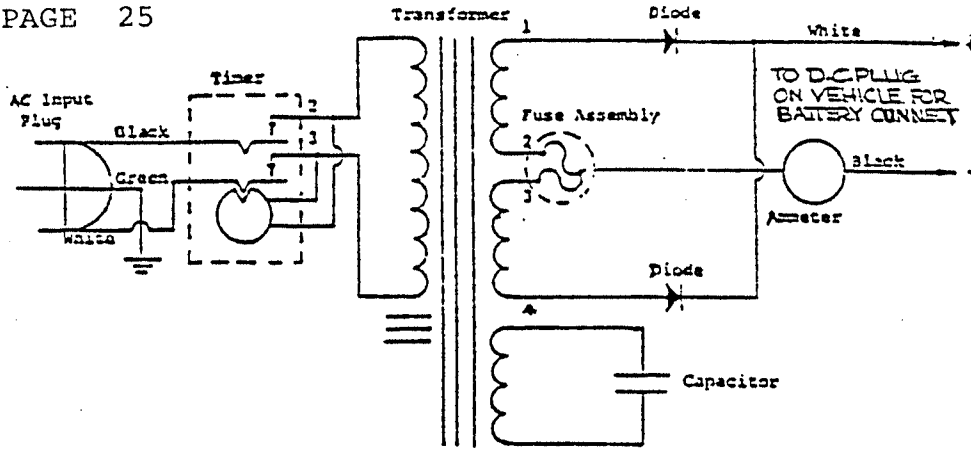

A. TYPICAL PORTABLE CHARGER

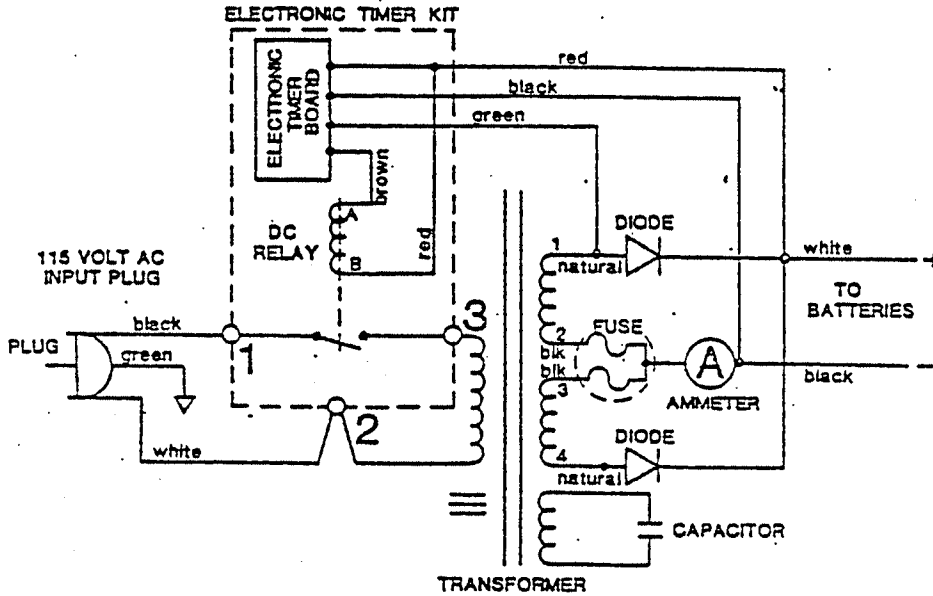

B. TYPICAL PORTABLE ELECTRONIC TIMER CHARGER (LESTRONICII)

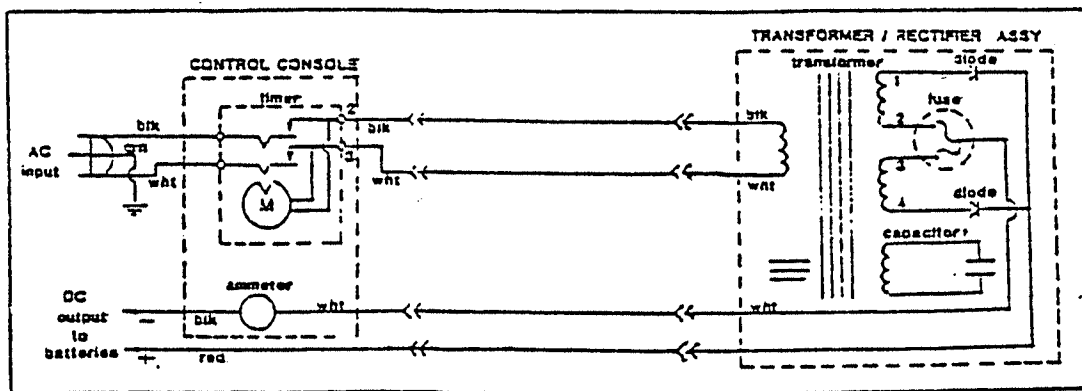
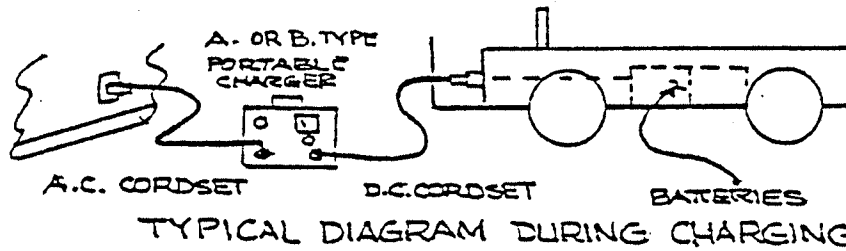

SCHEMATIC, LESTER CHARGER
TYPICAL FOR ALL BUILT-IN CHARGERS

RECOMMENDED REPLACEMENT PARTS
FOR SS CHARGERS

Taylor-Dunn Part No.	PORTABLE 79-300-00	BUILT-IN 79-300-05	PORTABLE 79-301-00	BUILT-IN 79-301-05
Lester Model No.	24LC25T12 115/60 8824	24LC25-3T12 115/60 7675	PORTABLE LESTRONIC III 9510 24LC25 115/60	LESTRONIC II 24LC25 115/60 7210
Transformer/Rectifier Assembly, Complete				
Transformer	79-644-10	79-644-10	79-644-11	
Capacitor	79-902-00	79-902-00	79-902-00	79-902-00
Ammeter	79-851-10	79-851-10		
Timer	79-805-00	79-805-11	79-805-64	79-805-64
Knob, Timer	79-806-00	79-806-00		
Heat Sink Assy. w/Diodes	79-749-10	79-749-11	N/A	N/A
Diode Replacement	79-745-10	79-745-10	79-745-10	79-745-10
Fuse Assembly	79-831-00	79-831-00	79-831-00	79-831-00
Cordset, A.C.	79-575-10	79-575-10		
Cordset, D.C.	79-566-10			
Bushing for Cordset A.C.	79-530-00	79-530-00		
Bushing for Cordset D.C.	79-530-00	79-530-00		
Plug, D.c. Replacement	76-003-00			

MAINTENANCE PROCEDURES

BODY AND TRIM

Your vehicle has been finished with several coats of durable baked on enamel.

It will require the same care as you would give your automobile. The chrome trim is also resistant to corrosion and will require an occasional cleaning.

It is recommended that your vehicle be washed with a mild soap and warm water. For long life a good automotive type of wax will extend the life of the finish and maintain lasting beauty.

For identification of Body and Trim Parts available for repair and replacement, refer to the following pages in this section.

TAYLOR DUNN MFG. CO.
2114 West Ball Rd.
A eim, Calif.

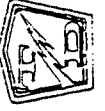

90-090-61
BOLT ON REAR STEP

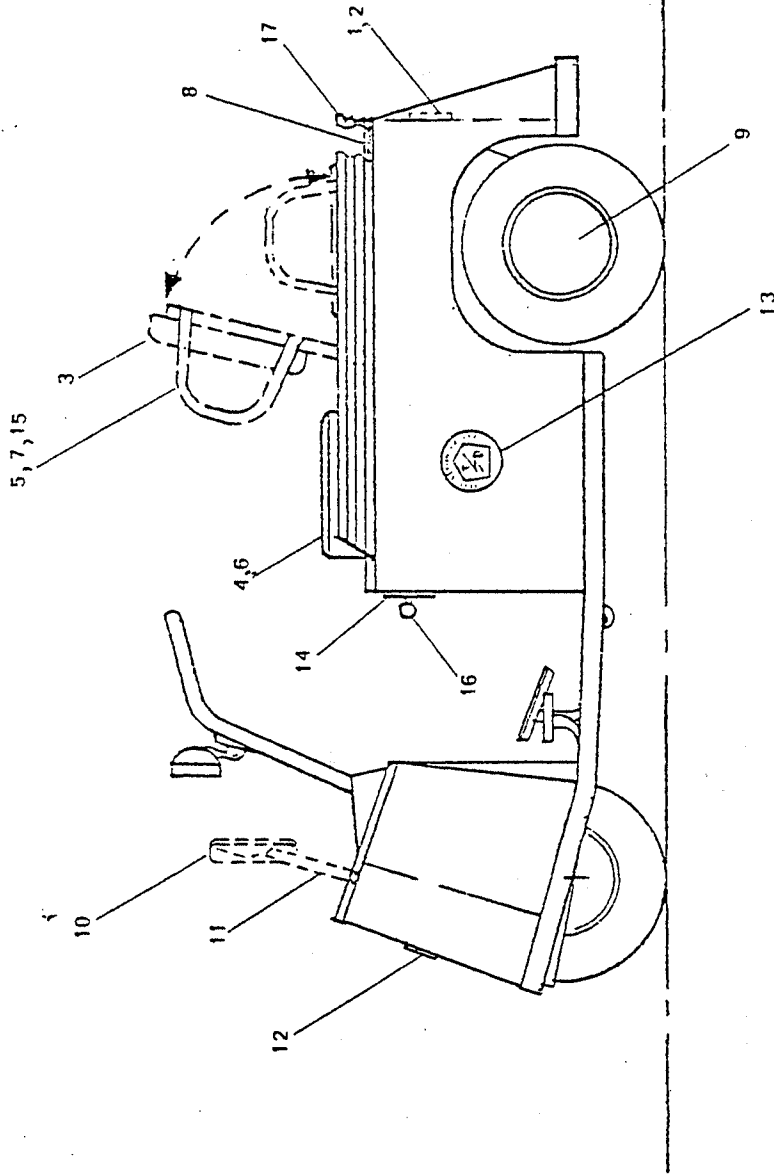

LENGTH QUAN. REVISED DATE REVISION

BODY AND TRIM PARTS
MODEL 2534 SS

FIGURE 11
SECTION J9

SECTION J9
PAGE 2

NO.	DESCRIPTION
TOL. FRAC.	DEC.
SCALE	
DRAWN BY	TEA
DATE	8-11-74

BODY & TRIM PARTSREFER TO FIGURE 11

FIG. I.D. NO.	T-D PART NO.	DESCRIPTION	QTY. REQ.
11-1	71-650-00	3" Red Reflector	1
11-2	72-022-51	Rubber Ring	0 or 2
11-3	90-144-00	Seat, Backrest	1
11-4	90-166-00	Seat, Cushion	1
11-5	90-109-50	Seat Backrest Frame, Bolt-On	1
11-6	90-109-51	Seat Back Frame, Base Bolt-On	1
11-7	90-106-61	Kit, Convertible Seat Backrest - Including Hardware	1
11-8	90-409-00	Deckboard	1
11-9	92-001-00	Chrome Wheel, Covers (6") for 4.00 x 8 Wheel	2
11-10	92-201-00	4-1/2 x 8-1/2 Mirror	1
11-11	92-202-00	Mirror Bracket	1
11-12	94-201-00	Taylor-Dunn Emblem	2
11-13	94-301-00	Taylor-Dunn Decal	2
11-14	94-307-00	Forward/Reverse Switch Plate	1
11-15	96-203-00	Thumbscrew for Locking Backrest	1
11-16	95-907-00	Knob, 1-1/4 Diameter Black Plastic	1
11-17	94-025-51	Aluminum Rear Deck Trim	1

PARTS NOT ILLUSTRATED

94-313-00	Decal, Battery Warning	1
91-812-00	Hinge, Deck Board	2
50-235-00	1/4 Battery Rod - 21-3/4" Long	0 or 2
77-864-00	Strap, Battery Hold Down 14-1/8" Long	1
94-309-50	Decal Brake Warning	1
94-378-00	Data Plate Battery Box (Vehicles without Lift Out Battery Box Only)	1
77-976-51	Lift Out Battery Box Frame	1
77-976-61	Lift Out Battery Box Kit Including Wiring, Receptacle Hardware, Less Batteries	As Req'd.
95-953-XX	Paint, 1 Gallon Can (Specify Color)	As Req'd.
95-954-XX	Paint, Spray Can (Standard Colors) 16 oz.	As Req'd.
95-952-XX	Paint, 1 Quart Can (Specify Color)	As Req'd.
94-373-00	Data Plate, Vehicle	1
94-313-50	Decal, Battery Disconnect	1
50-239-00	1/4 Battery Rod with bend, 1/4" Dia. x 19" Long UNC Threaded one end 1-1/4" Long	0 or 2

FASTENERS

USED WITH I.D. NO.	T-D PART NO.	DESCRIPTION	QTY. REQ.
11-7	88-108-60	3/8 Washer	2
11-7	88-101-16	3/8 N.C. x 2 Hex Head Screw	2
11-7	88-109-80	3/8 N.C. Hex Nut	2
11-6	88-065-13	1/4 x 1-1/4 Truss Head Screw	4
11-6,17	88-068-60	1/4 Cut Washer	4
11-6,17,11	88-069-87	1/4 Fastite Nut	10
11-6,8,4	88-837-13	#14 x 1-1/4 Phillips Head Screw	4
11-17	88-737-08	3/16 Diameter x 5/8 Aluminum Pop Rivet	5
11-14	88-727-06	5/32 Diameter x 1/2 Aluminum Pop Rivet	4
11-12	88-557-91	1/8 Push on Nut	6
All Data & Serial Plates	88-807-01	#4 x 3/16 Drive Screw, Round Head	10
11-8	88-065-09	1/4 x 3/4 N.C. Truss Head Machine Screw	8
11-17,11	88-065-08	1/4 x 5/8 N.C. Truss Head Machine Screw	4
11-3,5	88-837-09	#14 x 3/4 Phillips Head Sheet Metal Screw	6

PWR-TRON 240, 350 & 480

TABLE OF CONTENTS

<u>CONTENTS</u>	<u>PAGE</u>	<u>NUMBER</u>
INTRODUCTION	1	
GENERAL/FEATURES	2	
CURCUITS AND OPERATION	3	
OPERATION	4	
PREVENTIVE MAINTENANCE	5	
ACCELERATOR MODULE	6 & 7	
PWR-TRON 240 ASSEMBLY & PARTS LIST	8	
PWR-TRON 350 ASSEMBLY & PARTS LIST	9	
PWR-TRON 480 ASSEMBLY & PARTS LIST	10	
SOLENOID PANEL ASSEMBLIES (24 & 36 VOLTSØ	11	
CONTACTOR PANEL (48 VOLT)	12	
COMBINED CONTROL & POWER SCHEMATIC (FIG. 1)	13	
CONTROL CIRCUIT SCHEMATIC (FIG. 2)	14	
POWER CIRCUIT SCHEMATIC (FIG. 3)	15	
POTENTIOMETER CHECK & ACCELERATOR LINKAGE ADJ.	16,17,18	
CONTINUITY AND POWER CHECK	19	
PWR-TRON 240 TRIMPOT ADJUSTMENTS	20	
PWR-TRON 350/480 TRIMPOT ADJUSTMENTS	21	
TROUBLE SHOOTING STEPS	22 & 23	
RECOMMENDED SPARE PARTS	24	

INTRODUCTION

This supplement has been prepared for the purpose of familiarizing the owner with the operational features of the Taylor-Dunn PWR-TRON solid state speed controls. The PWR-TRON 240, 350 and 480 is developed and available only from Taylor-Dunn and is warranted for one full year. Modifications to the control unit, drive or power system will void the warranty.

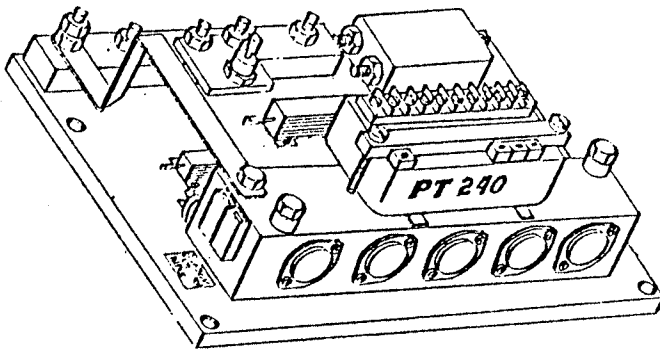

24 OR 36 VOLTS
RECOMMENDED FOR
USE UP TO 6 HP
MOTORS
(INTERMITTENT)

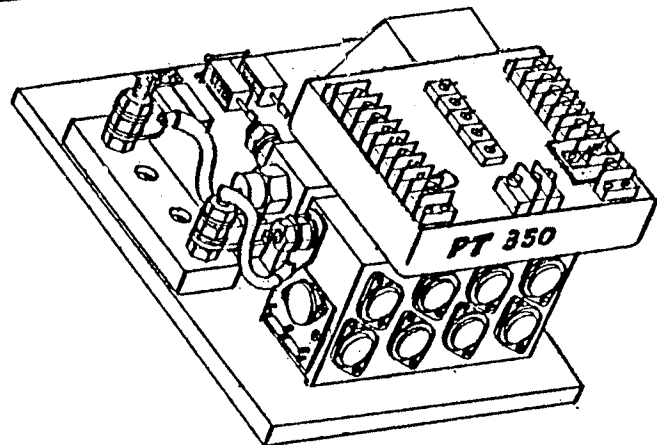

24 OR 36 VOLTS
RECOMMENDED FOR
USE UP TO 10 HP
MOTORS
(INTERMITTENT)

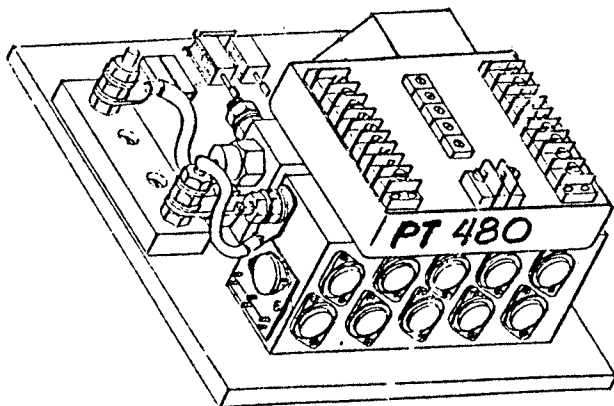

48 VOLTS ONLY

PWR-TRON 240, 350 AND 480

GENERAL

The PWR-TRON unit is readily accessible when the seat on Model R's is raised, or in other models, under the deck board. The PWR-TRON unit performs two functions; forward-reverse and acceleration via mechanical linkage to the foot pedal. You will notice the PWT-TRON unit is a transistorized supply that regulates the voltage fed from the battery through the accelerator module to provide the necessary signal to the motor. This gives the operator full control of the vehicle at all speeds and braking under all conditions.

FEATURES

Some of the inherent advantages over conventional (resistor type) speed controls are:

1. Increased range; 30% (mileage may vary).
2. Positive current limit; increases motor and battery life.
3. No maintenance to PWR-TRON required.
4. Power matched to motor; providing maximum power output during towing or hauling.
5. Thermal protection to prevent over heating and damage to PWR-TRON.
6. Unit is protected from incorrect battery hookup.
7. "Low" battery protection through solenoid drop out.
8. "Built-in" motor short protection; prevents run away currents and high temperatures, should a motor short occur.
9. Controlled acceleration for smooth starting; no more jack rabbit starts.
10. Plug braking; while accelerator is fully depressed, reverse direction switch, vehicle will automatically slow down, then accelerate in reversed direction. Note, by letting up on the accelerator then re-accelerating, a smoother control will be achieved.
11. Modular construction provides simplicity in trouble shooting, parts replacement and servicing in the field.
12. Each unit has a thermocouple that shuts off power at 160 degrees F which is the operational limit of the PWR-TRON. The unit automatically resets when it has cooled to approximately 130 degrees F.

PWR-TRON 240, 350 & 480

* CIRCUITS AND OPERATION

There are two circuits included in the operation of the PWR-TRON, the control circuit and the power circuit.

The control circuit (light gauge wire) includes key switch, micro-switch, MS-1, potentiometer; R1, activated by the accelerator arm on back of accelerator module, the PWR-TRON solid state controller, forward reverse switch and solenoid panel.

The power circuit (heavy gauge wire) includes the batteries, forward reverse switch and motor.

The two circuits operate as follows: (refer to Fig.1)

CONTROL CIRCUIT (see Fig. 2)

Forward operation. Turn key switch to "ON" position and forward-reverse switch to forward position, MS-1 is closed providing a current path to the forward solenoid coil and closing forward contact on the forward-reverse switch. As the accelerator is depressed, the potentiometer, R1, will increase the current, moving the vehicle forward.

Reverse operation. Turn key switch to "ON" position and forward-reverse switch to reverse position, MS-1 is closed providing a current path to the reverse solenoid coil and closing the reverse contact on the forward-reverse switch. As the accelerator is depressed, the potentiometer, R1, will increase the voltage, moving the vehicle in reverse.

POWER CIRCUIT (see Fig. 3)

Forward operation . When the control circuit is energized and the solenoid contacts are closed, the current flow is then channeled through the PWR-TRON and then to the power wiring. Motor speed is controlled by voltage output from the PWR-TRON. The PWR-TRON is varied by the potentiometer, R1, in the control circuit.

Reverse operation. The same circuit is used as forward operation except the forward-reverse switch is moved to reverse current flow through the motor.

* Circuits of Figures 1, 2 and 3 are the same for PT240, PT350 and PT480.

OPERATING YOUR PWR-TRON 240, 350 & 480 EQUIPPED VEHICLE

To put your vehicle into operation, turn ignition key to "ON". Select direction you wish to travel by moving forward/reverse switch to desired position. Release parking brake, slowly depress accelerator pedal until vehicle is moving at desired speed.

You will notice your vehicle has a smooth transition from start to high speed operation. This is a built-in characteristic of the PWR-TRON speed control, avoiding "jack-rabbit" starts.

"Plug braking" is an additional feature of the PWR-TRON. It is not necessary to come to a complete stop before reversing the vehicle. It is only necessary to reverse the vehicle while it is in motion and accelerator is fully depressed. The vehicle will automatically slow to an immediate stop and reverse itself to full acceleration. "Plug braking" should be done in an obstruction free area until the operator gets the feel for this maneuver. This maneuver does not damage the PWR-TRON. It is recommended when starting the vehicle to be sure to always turn ignition key on first then select direction of travel with the forward reverse switch, before depressing the accelerator pedal.

PWR-TRON 240, 350 & 480 PREVENTIVE MAINTENANCE

WARNING

BEFORE WORKING ON THE PWR-TRON UNITS OR ANY PART OF THE VEHICLE ELECTRICAL SYSTEM, DISCONNECT BOTH THE MAIN POSITIVE AND NEGATIVE BATTERY LEADS. PLACE THE FORWARD/REVERSE LEVER IN NEUTRAL, TURN OFF AND REMOVE. ALWAYS SET PARKING BRAKE.

No regular maintenance is required.

Be sure ignition key is on before depressing accelerator pedal. DO NOT depress pedal then turn on key. This is unsafe operation.

CAUTION

Do not steam clean or spray with water.

Make sure all wire connections are secure.

There are three modules as part of this system, solenoid panel, accelerator module and PWR-TRON module. These are all easily removable for replacement and service.

Only qualified service personnel should perform any replacement, adjustments or servicing of the PWR-TRON module, solenoid panel or the accelerator module. This will avoid the possibility of voiding your warranty on the PWR-TRON 240, 350 or 480.

When returning vehicle to pre-service configuration make certain batteries are properly connected to avoid damage.

ACCELERATOR MODULES
PT240, 350 AND 480

GENERAL FEATURES

All accelerator modules parts list are identical for all vehicles except for the rotor. This difference is noted on the following drawings and parts list. The orientation of the accelerator are is shown mounted in the "OFF" position for all vehicles. All parts lists figures are identified in order of assembly. Whenever a re-assembly is necessary a potentiometer check is required before adding pulleys and belts.

MICRO-SWITCH CHECK

Using a VOM, with micro-switch in "ON" position. Red wires should read Zero OHMS and OFF position will read infinity.

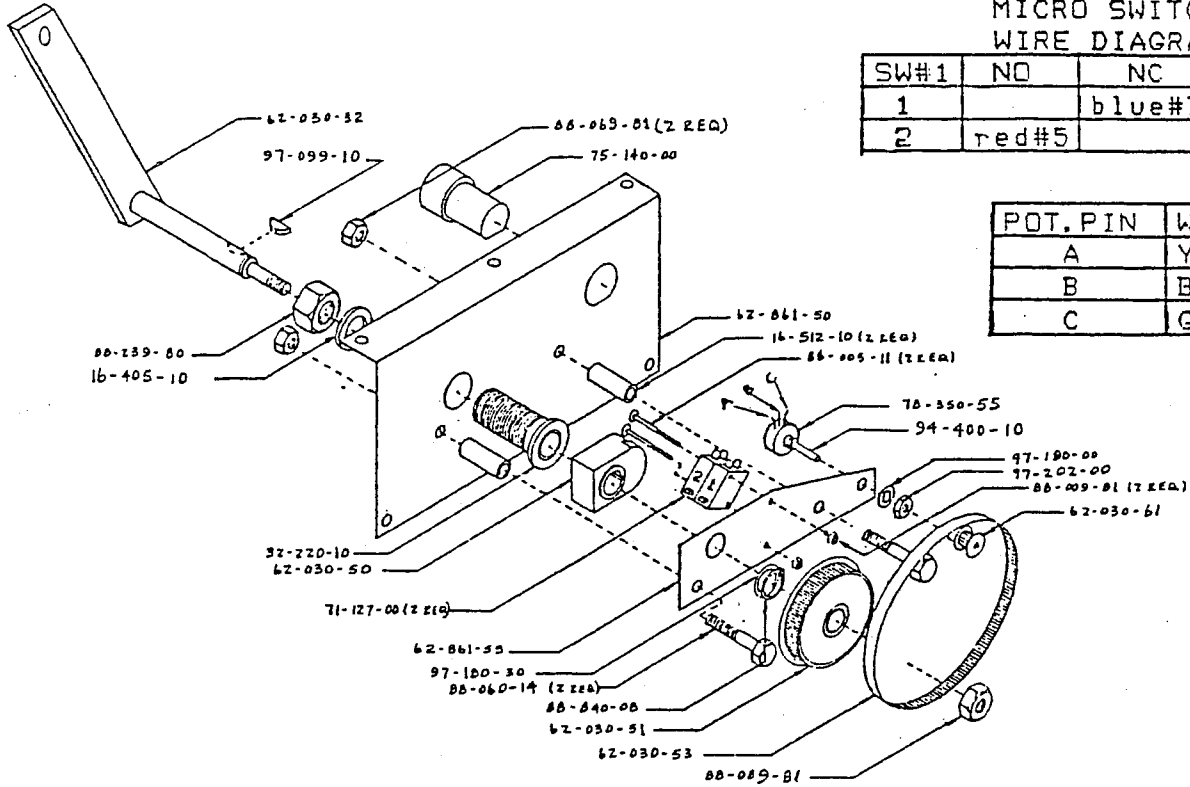

PAGE 7
MICRO SWITCH
WIRE DIAGRAM

SW#1	NO	NC	COM
1		blue#7	blue#6
2	red#5		red #4

POT. PIN	WIRE #
A	YELLOW #1
B	BLACK #2
C	GREEN #3

ACCELERATOR MODULE (COVER NOT SHOWN) 62-030-12
(TYPICAL) MODEL 1248B, ITEM 10 CHANGES
FROM VEHICLE TO VEHICLE

FIG. NO.	PART NO.	DESCRIPTION	QTY.
1	62-861-55	Plate, Pot. Mtg. Accel Module	1
2	71-127-00	Switch, Micro	2
3	88-055-11	Screw, 4-40 X 1-1/4 Truss Hd.	2
4	78-350-55	Potentiometer	1
5	97-190-00	Washer, Potentiometer	1
6	97-202-00	Nut, Potentiometer	1
7	88-009-81	Washer, 4-40 Lock	2
8	62-030-61	Sprocket 18T .0800	1
9	32-220-10	Bushing, 1/2 ID, Brass	1
*10	62-030-32	Rotor, Accel. Module (1248B)	1
11	97-099-10	Key, Woodruff	1
12	88-239-80	Nut, 3/4 NF Hx. Hd. Nut	1
13	88-229-62	Washer, 3/4 Lock	1
14	62-861-50	Plate, Backing, Accel. Module	1
15	62-030-50	Cam, Micro Sw. 1 In. Rad.	1
16	16-512-10	Spacer, 1/4 ID X 29/32 St. Tubing	2
17	88-060-14	Screw, 1/4 X 1-1/2	2
18	88-069-81	Nut, 1/4 Lock	2
19	75-140-00	Harness, Accel. Module	1
20	97-180-30	Washer, 1/2 In ID X 1/32 Thk.	1
21	88-840-08	Ring, Snap 1/2 Ext. Fleet Pk.	1
22	62-030-51	Sprocket, 80T .0800	1
23	62-030-53	Belt, .0800 12 In 150 T	1
24	88-088-62	Nut, 5/16 NC, Lock	1
	62-030-58	Cover (Not Shown)	1
*	62-030-34	Rotor, Accel. Module (Model C)	1
*	62-030-35	Rotor, Accel. Module (Model E)	1
*	62-030-31	Rotor, Accel. Module (374 R)	1
*	62-030-44	Rotor, Accel. Module (R 3-80)	1
*	62-030-33	Rotor, Accel. Module (B 2-10)	1

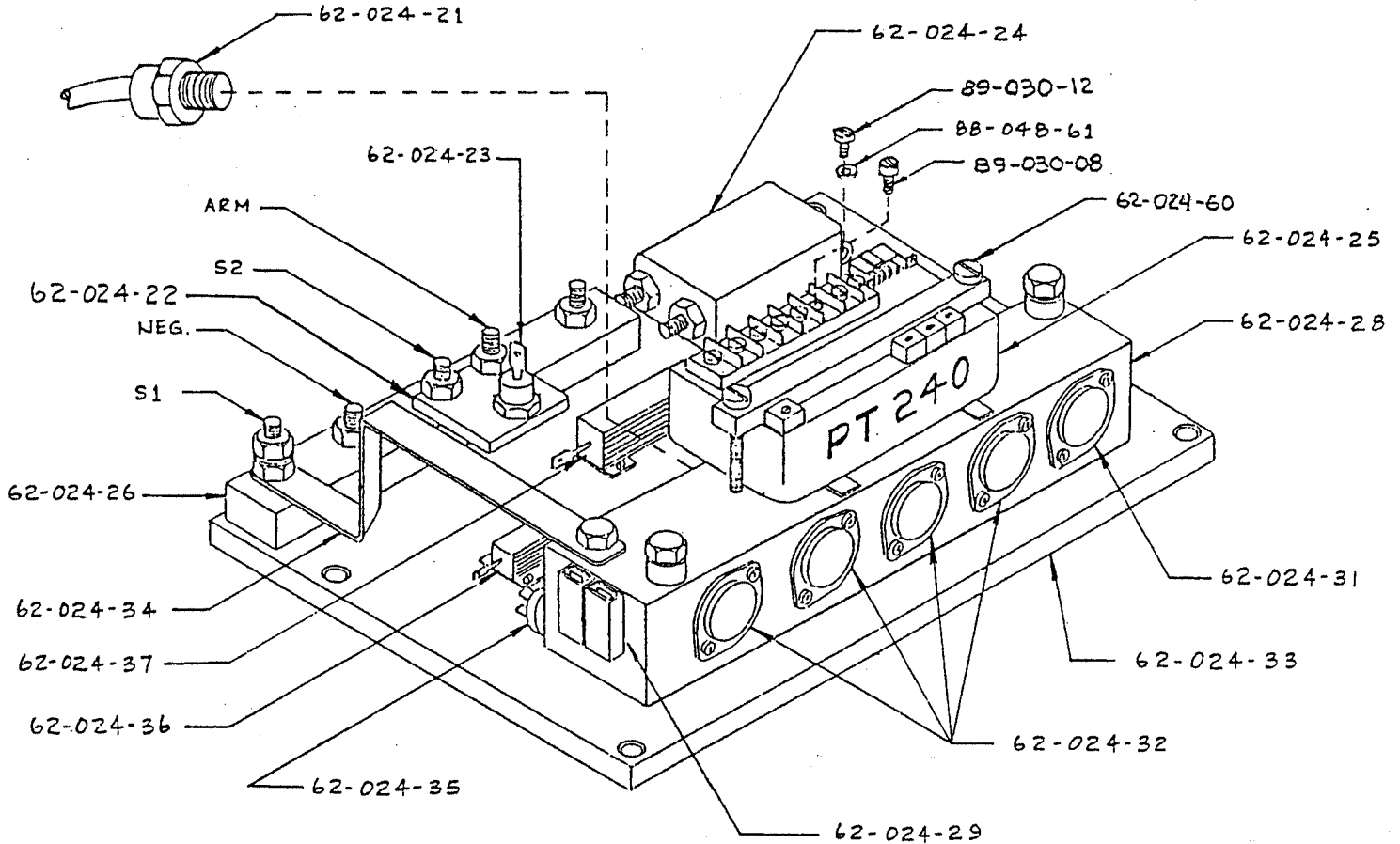

PT240 SPEED CONTROLLER AND PARTS LIST
(PT240 TYPICAL FOR ALL 24 & 36 VOLT VEHICLES)

PART NO.	DESCRIPTION	QTY.
62-024-21	Diode, Flywheel	1
62-024-22	Heat Sink, Diode, Plugging	1
62-024-23	Diode, Plugging	1
62-024-24	Capacitor	1
62-024-25	Logic Unit	1
62-024-28	Transistor Block	1
62-024-31	Transistor Driver	1
62-024-32	Transistor Power	(set) 4
62-024-33	Base, PT240	1
62-024-29	Switch Key (24V & 36V)	1
62-024-35	Switch, Thermal	1
62-024-36	Resistor, 70 OHM	1
62-024-37	Resistor, 1/2 OHM	1
62-024-34	Bar, Buss	1
62-024-26	Block, Terminal	1
89-030-12	Screw, 3 MM x 12 MM	7
89-030-08	Screw, 3 MM x 8 MM	10
62-024-60	Kit, Logic Bar & 2 Screws	2
88-048-61	Washer, # 10 SAE	7

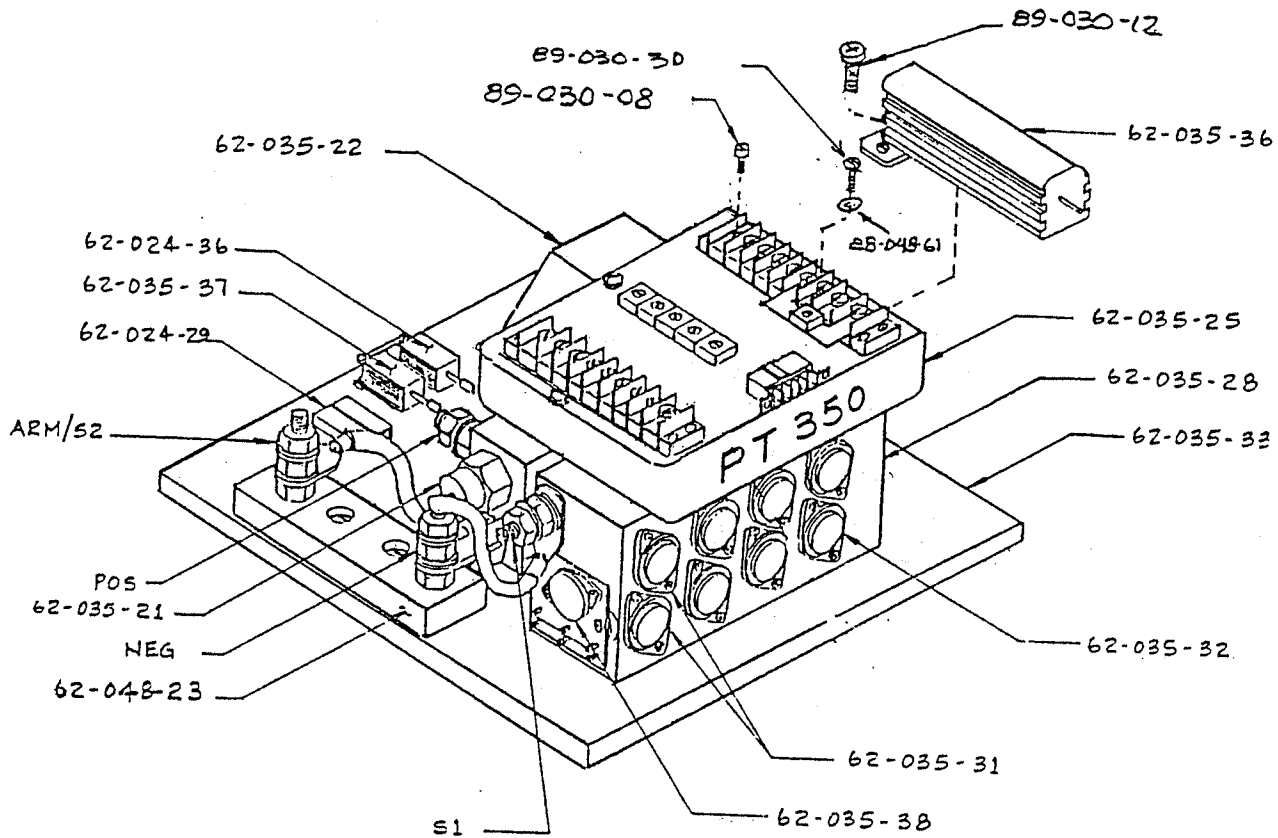

PWR-TRON 350 SPEED CONTROLLER, 24/36 VOLTS

<u>PART NO.</u>	<u>PT350</u>	<u>DESCRIPTION</u>	<u>QTY.</u>
62-035-21		Diode, Flywheel	1
62-035-21		Diode, Plugging	1
62-035-22		Capacitor	1
62-035-25		Logic Unit	1
62-035-28		Block, Transistor	1
62-035-33		Base Plate	1
62-035-32		Transistors, Power (set of 6)	1
62-035-31		Transistors, Driver	2
62-035-38		Transistor Assy. Driver, Driver	1
62-048-23		Block Terminal	1
62-024-29		Key Switch	1
62-024-36		Resistor, 10 W 70 OHM	1
62-035-36		Resistor, 50 W .5 OHM	1
62-035-37		Resistor, 10 W 18 OHM	1
89-030-08		Screw, 3 MM x 8 MM	25
89-030-12		Screw, 3 MM x 12 MM	10
88-048-61		Washer, # 10 SAE	3
89-030-30		Screw, 3 MM x 30 MM	3

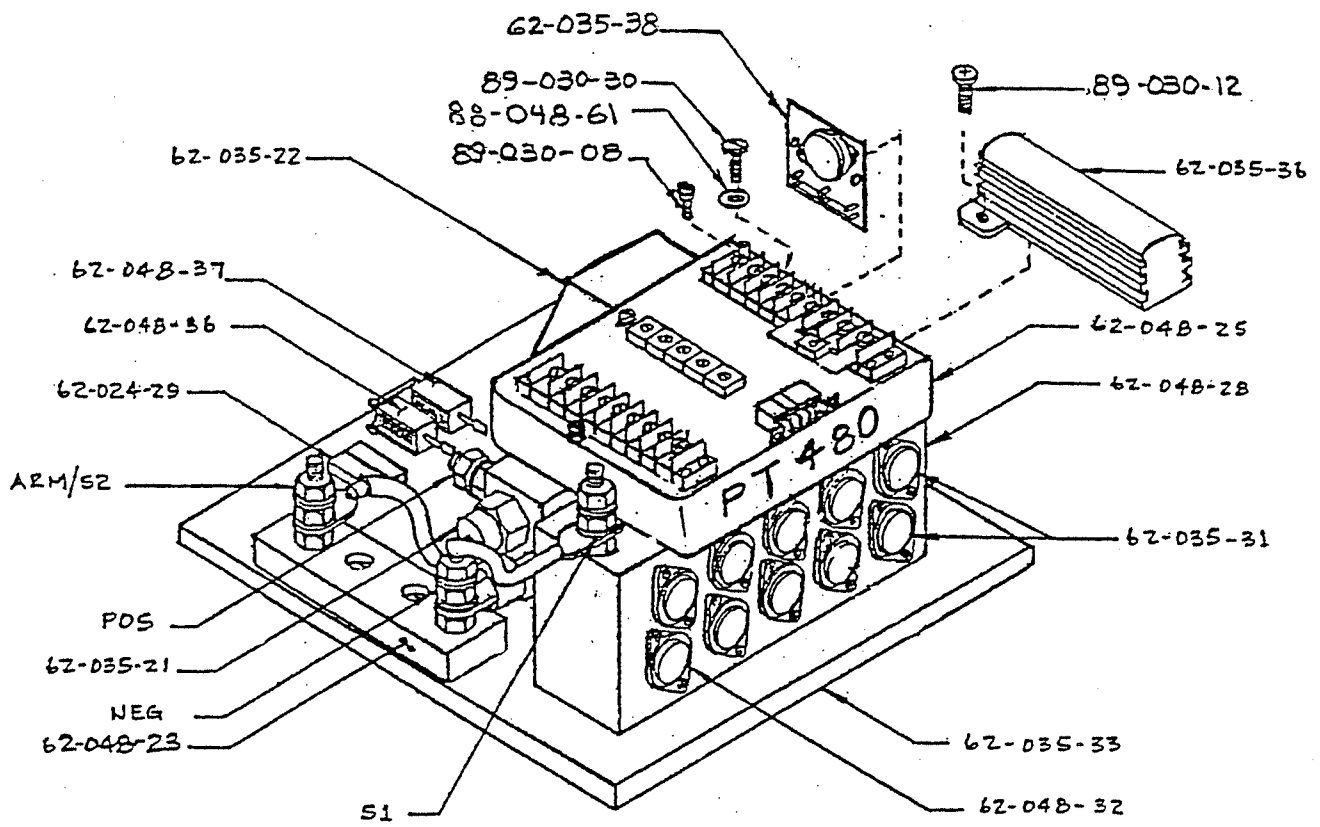

PWR-TRON 480 SPEED CONTROLLER, 48 VOLTS

<u>PART NO.</u>	<u>PT480</u>	<u>DESCRIPTION</u>	<u>QTY.</u>
62-035-21		Diode, Flywheel	1
62-035-21		Diode, Plugging	1
62-035-22		Capacitor, Filter with Nuts	1
62-048-25		Logic Unit	1
62-048-28		Block, Transistor	1
62-048-32		Transistor, Power (set of 8)	1
62-035-31		Transistor, Driver	2
62-035-38		Transistor Assembly Driver/Driver	1
62-035-33		Plate, Base	1
62-048-23		Block, Terminal	1
62-049-29		Input, Key Switch	1
62-035-36		Resistor, 50 W .5 OHM	1
62-048-36		Resistor, 10 W 150 OHM	1
62-048-37		Resistor, 10 W 1K5 OHM	1
89-030-08		Screw, 3 MM x 8 MM	25
88-030-12		Screw, 3 MM x 12 MM	10
89-030-30		Screw, 3 MM x 30 MM	3
88-048-61		Washer #10 SAE	3

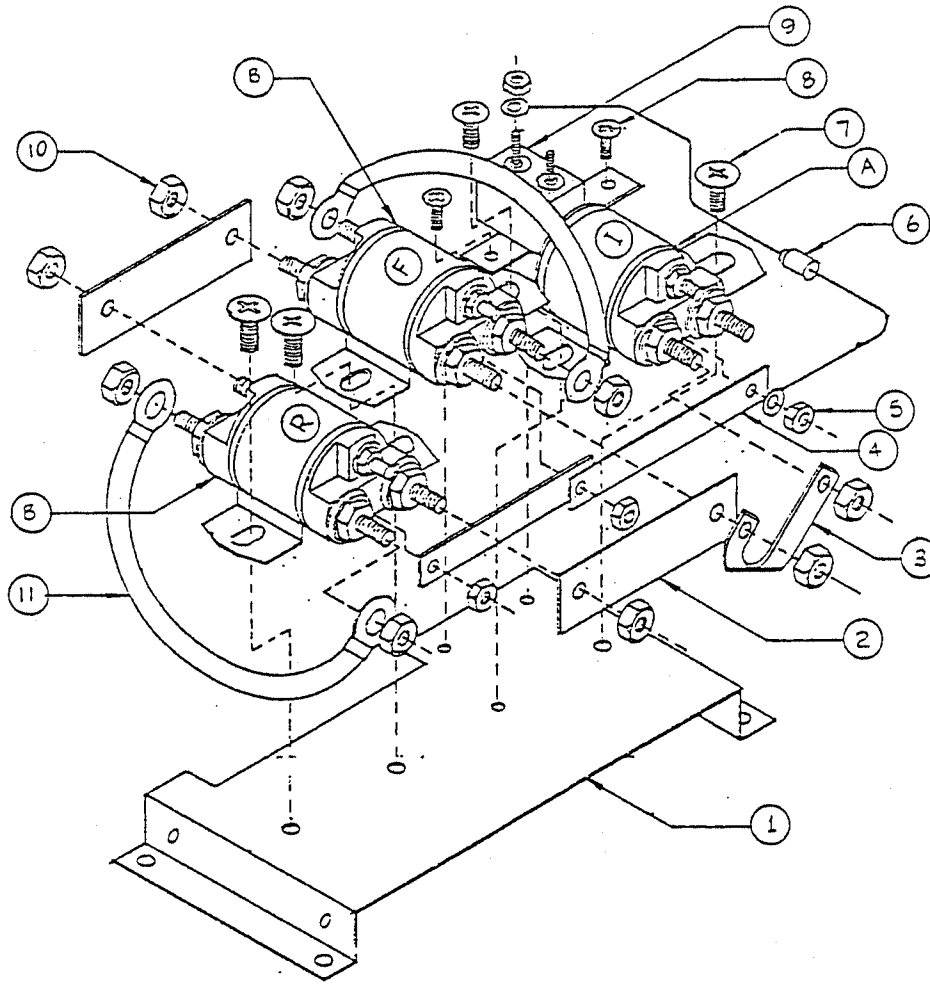

*SOLENOID PANEL ASSEMBLIES

72-560-00, 24V PANEL ASS'Y

72-560-10, 36V PANEL ASS'Y

A) 72-501-24 SOLENOID, SPST 24V

A) 72-501-36 SOLENOID, SPST 36V

B) 72-501-25 SOLENOID, SPDT 24V

B) 72-501-37 SOLENOID, SPDT 36V

*THE SOLENOID PANEL ASSY IS TYPICAL FOR
PT240 AND PT350 AND ARE INTERCHANGEABLE
DEPENDING ON VOLTAGE REQUIREMENTS

<u>FIG NO.</u>	<u>PART NO.</u>	<u>DESCRIPTION</u>	<u>QTY.</u>
1.	72-560-50	Panel, Solenoid Mtg	1
2.	61-838-51	Bar, Buss 2 X 5/8 CU	2
3.	61-838-20	Buss, Curved	1
4.	61-838-50	Bar, Buss 3 X 3/8 CU	2
5.	88-048-62	Nut	4
6.	75-224-10	Jumper, 5-1/4 IN, 18GA, W/Diode	1
7.	88-838-06	Screw, #14 X 1/2 Pan Head Sheet Metal	4
8.	88-818-06	Screw, #8 X 1/2 Pan Head Sheet Metal	2
9.	79-840-00	Circuit Breaker, 10 AMP	1
10.	88-089-91	Nut, Hex Jam, 5/16NC, Thin	9
11.	75-235-20	Jumper, Red, 4-1/4, 4 GA	2
	72-560-51	Cover, Solenoid Panel (Not Shown)	1

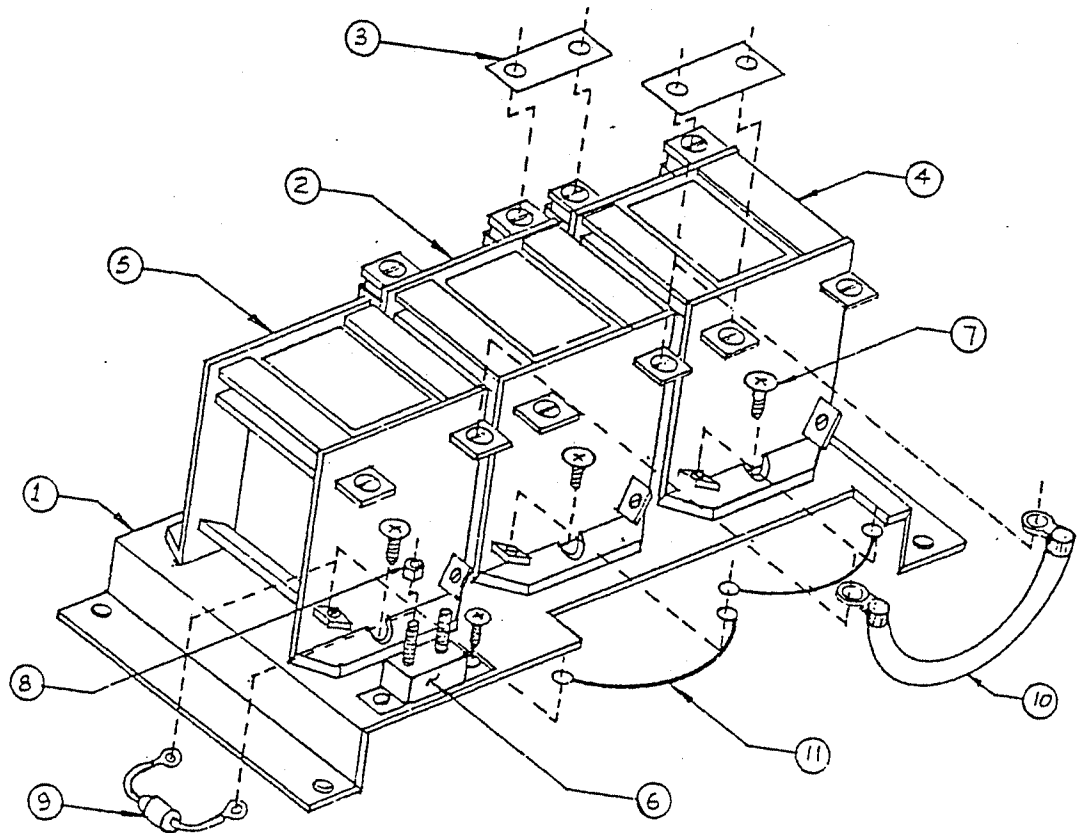

CONTACTOR PANEL ASSEMBLY 48V (72-560-20)
(FOR USE WITH PT 480 ONLY)

FIG. NO.	PART NO.	DESCRIPTION	QTY.
1	72-560-52	Panel, Contactor Mtg.	1
2	71-306-71	Contactor, Rev. 75 AMP 48V SPDT	1
3	61-838-52	Buss Bar, Copper, 1/2 X 1	2
4	71-306-70	Contactor, FWD. 75 AMP 48V DPST	1
5	71-306-72	Contactor, ISO. 75 AMP 48V SPST	1
6	79-840-00	Circuit Breaker, 10 AMP Auto	1
7	88-818-06	Screw, B X1/2 Pan Hd. Type B Thd.	8
8	88-049-80	Nut, 10-32 Hex	2
9	75-224-15	Jumper, With Diode	1
10	75-235-11	Jumper, 4 Ga. 2-1/2 In. Long	1
11	75-224-20	Jumper, 3 Inch 18 Ga. Black	2

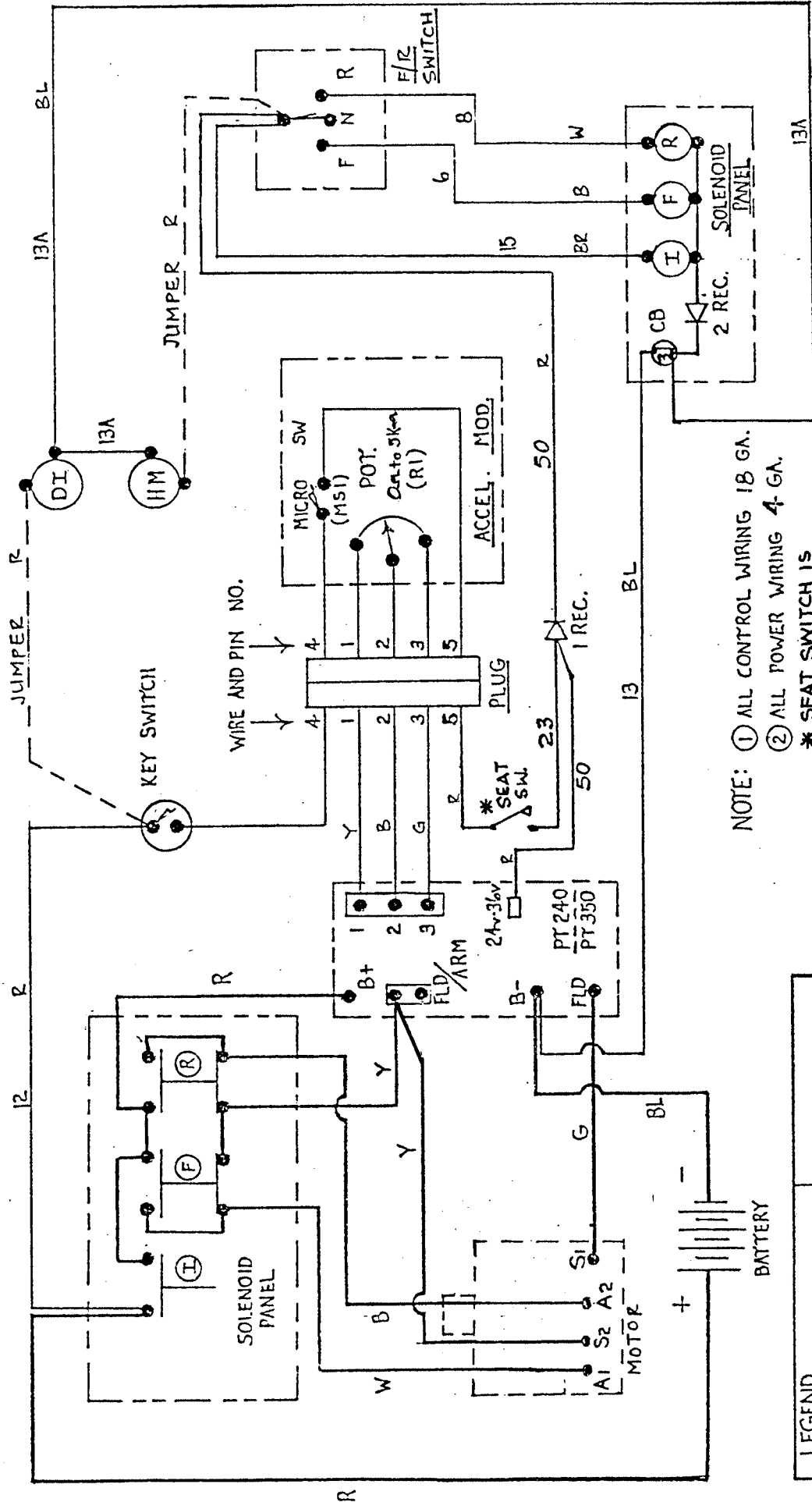

NOTE: ① ALL CONTROL WIRING 18 GA.
 ② ALL POWER WIRING 4 GA.
 * SEAT SWITCH IS OPTIONAL ON SOME VEHICLES

LEGEND	Y	YELLOW
REC	B	BIJUE
HM	W	WHITE
DI	G	GREEN
CB	BL	BLACK
I	R	RED
F	BR	BROWN
R		

PNR-TRON 240/350 COMBINED CIRCUIT
DIAGRAM WIRING SCHEMATIC. FIGURE 1.

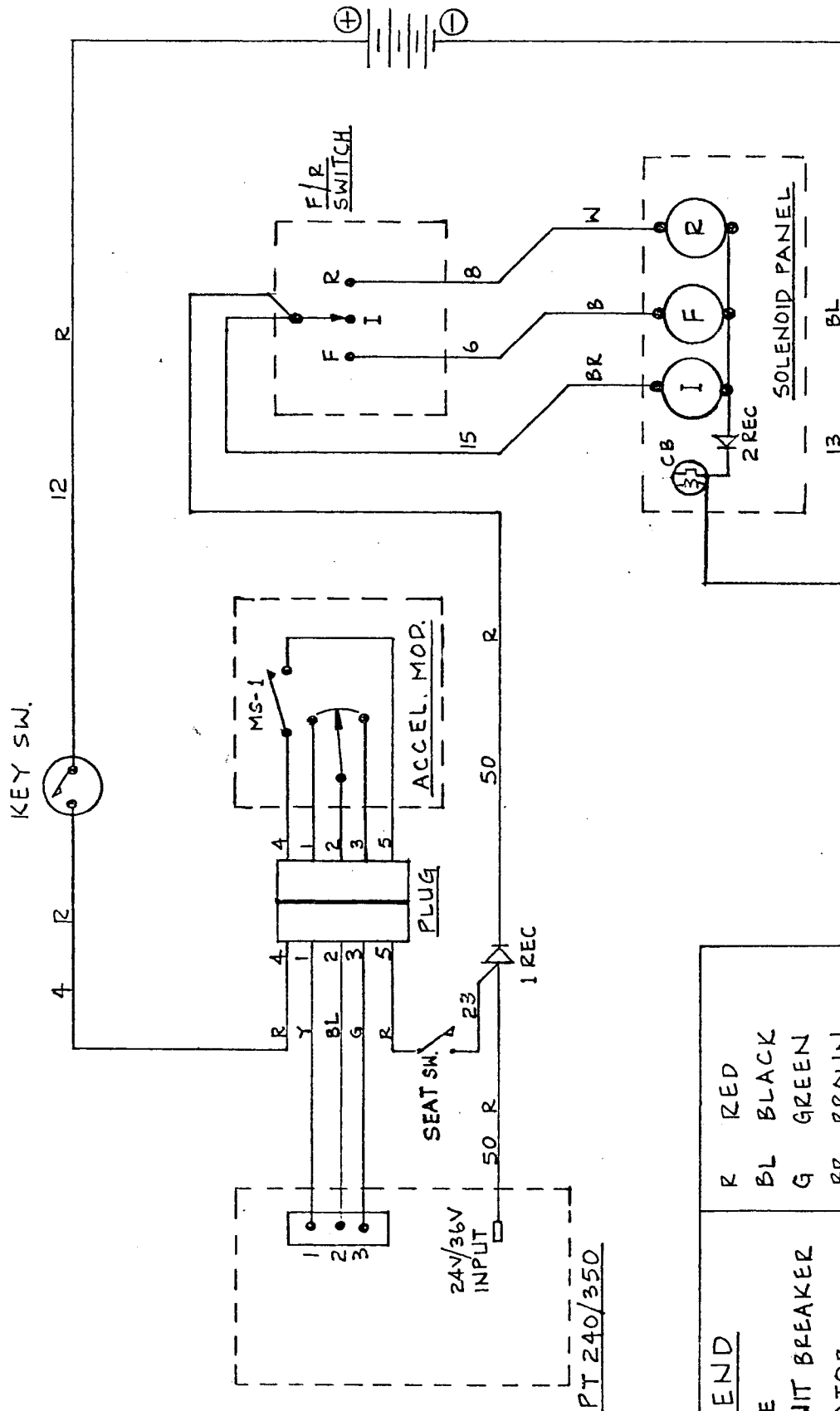

PWR-TRON 240/350 CONTROL SCHEMATIC FIG. 2

LEGEND	
REC	DIODE
CB	CIRCUIT BREAKER
I	ISOLATOR
F	FORWARD
R	REVERSE
R	RED
BL	BLACK
G	GREEN
BR	BROWN
Y	YELLOW
W	WHITE

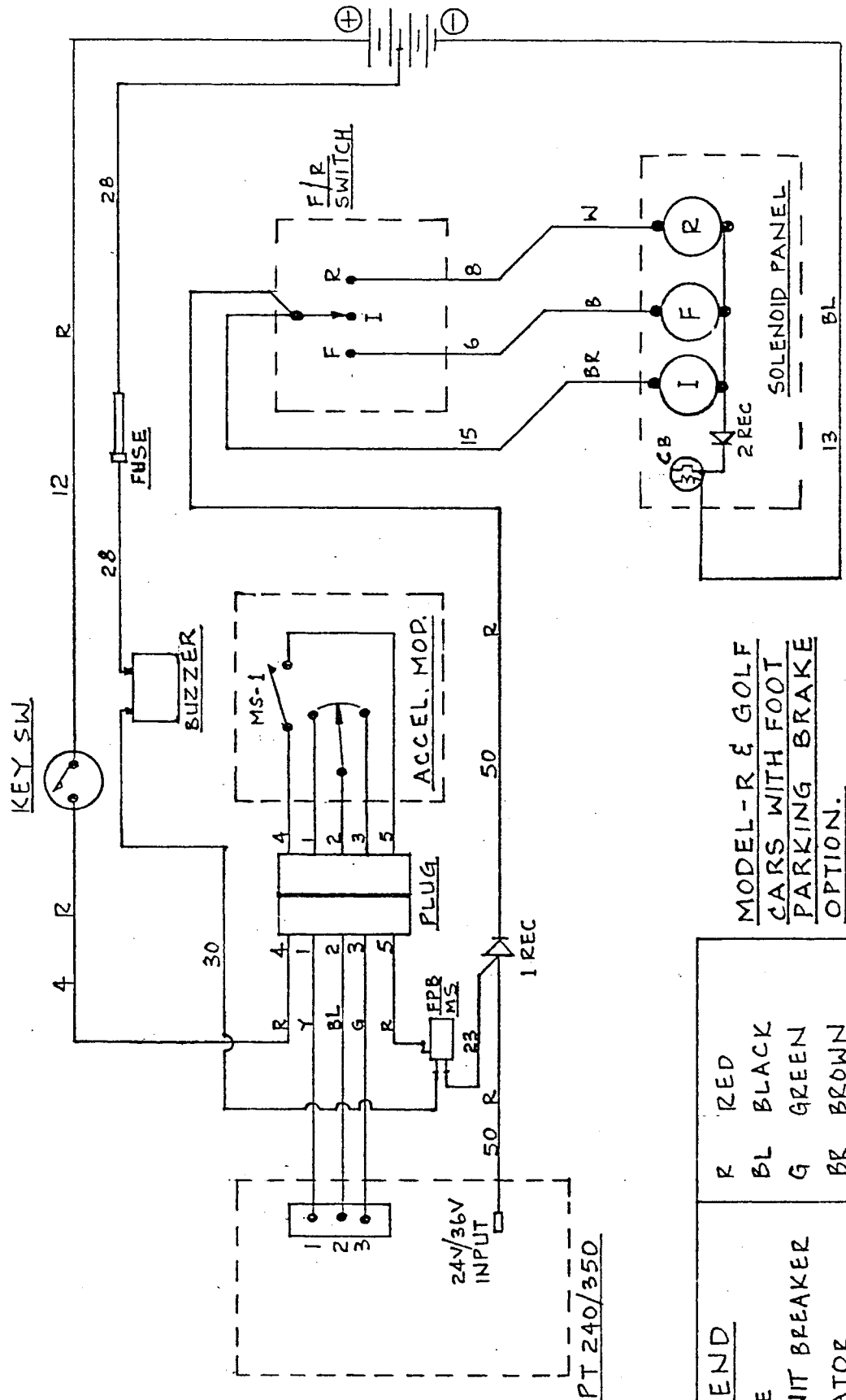

MODEL - R & GOLF
 CARS WITH FOOT
 PARKING BRAKE
 OPTION.

LEGEND	
REC	DIODE
CB	CIRCUIT BREAKER
I	ISOLATOR
F	FORWARD
R	REVERSE
R	RED
BL	BLACK
G	GREEN
BR	BROWN
Y	YELLOW
W	WHITE

PWR-TRON 240/350 CONTROL SCHEMATIC FIG. 3

LEGEND

B+	BATTERY POS.	R	RED
B-	BATTERY NEG.	BL	BLACK
FLD	FIELD	B	BLUE
ARM	ARMATURE	Y	YELLOW
I	ISOLATOR	G	GREEN
F	FORWARD	W	WHITE
R	REVERSE		

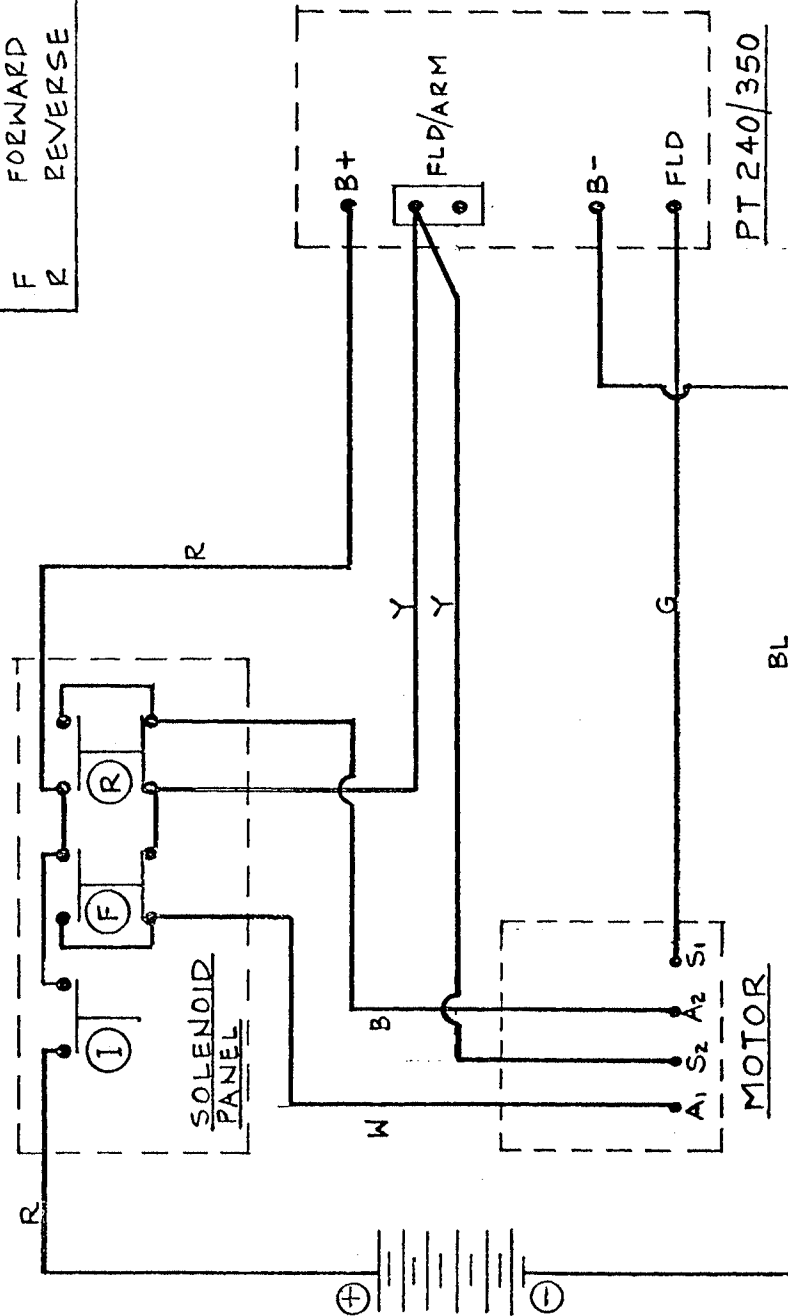

PWR - TRON 240/350 POWER SCHEMATIC FIG 4

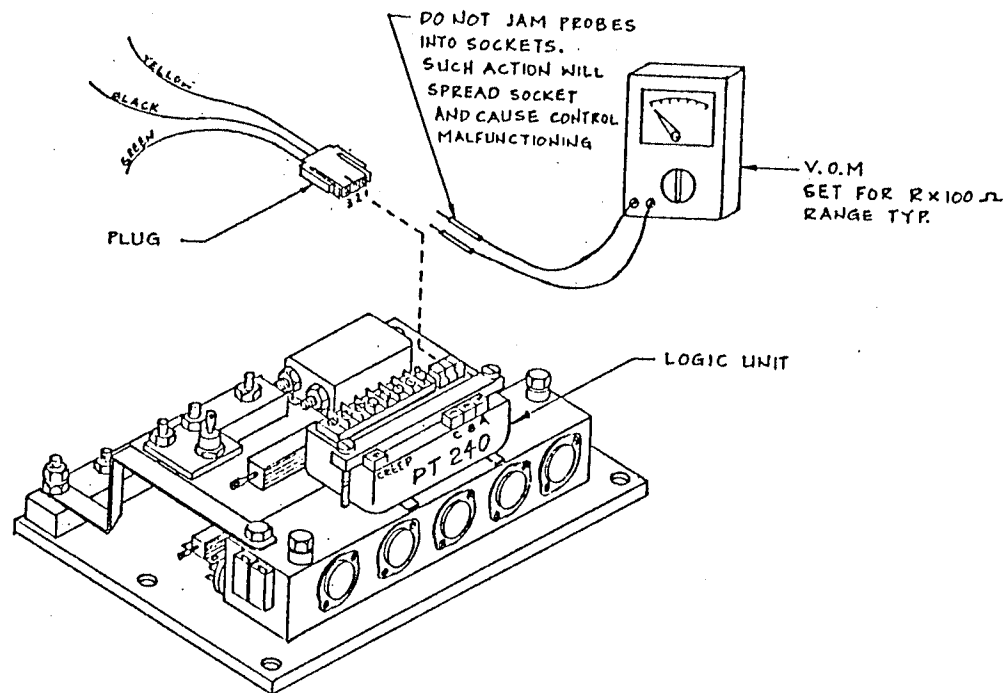

PWR-TRON 240 24/36 VOLTS

POTENTIOMETER CHECK & ACCELERATOR LINKAGE ADJUSTMENT

1. Disconnect plug (with yellow, black and green wires) at PWR-TRON logic.
2. Read 4K to 5K ohm on V.O.M. between sockets 1 and 2 (yellow and black wires) with accelerator pedal in off position.
3. With accelerator pedal full depressed, read 0 - 300 ohm on V.O.M. between sockets 1 and 2 (yellow and black wires). Adjust the accelerator pedal stop and/or accelerator linkage to achieve the above readings.
 - * DO NOT rely on return stop inside the accelerator module. It is only a safety feature, not designed for constant foot/pedal return pounding.
4. Reconnect plug to PWR-TRON 240 logic unit.

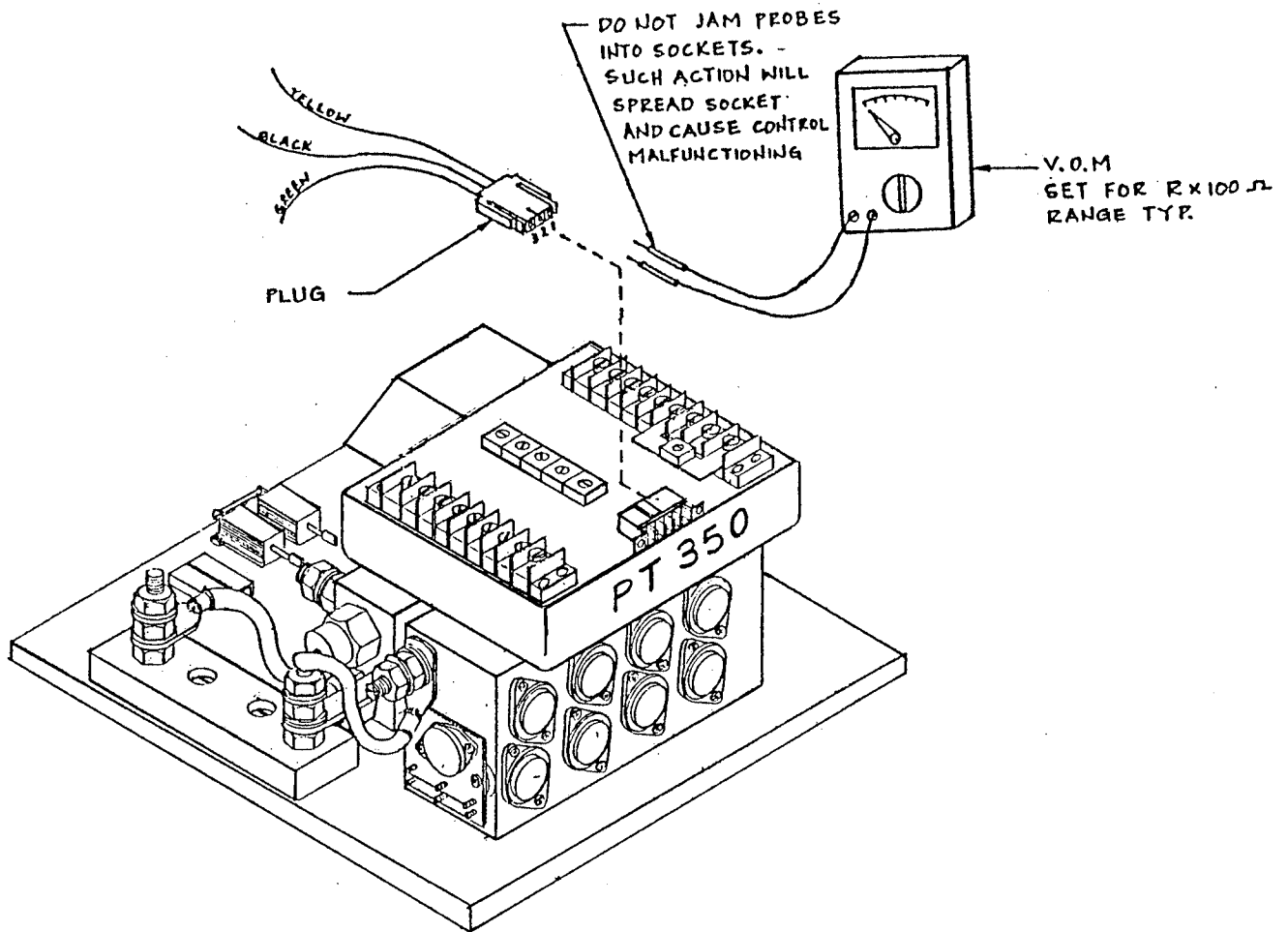

PWR-TRON 350 24/36 VOLTS

POTENTIOMETER CHECK & ACCELERATOR LINKAGE ADJUSTMENT

1. Disconnect plug (with yellow, black and green wires) at PWR-TRON logic unit.
 2. Read 4K to 5K ohm on V.O.M. between sockets 1 and 2 (yellow and black wires) with accelerator pedal in off position.
 3. With accelerator pedal fully depressed, read 0 - 300 ohm on V.O.M. between sockets 1 and 2 (yellow and black wires). Adjust the accelerator pedal stop and/or accelerator linkage to achieve the above readings.
- * DO NOT rely on return stop inside the accelerator module. It is only a safety feature, not designed for constant foot/pedal return pounding.
4. Reconnect plug to PWR-TRON 350 logic unit.

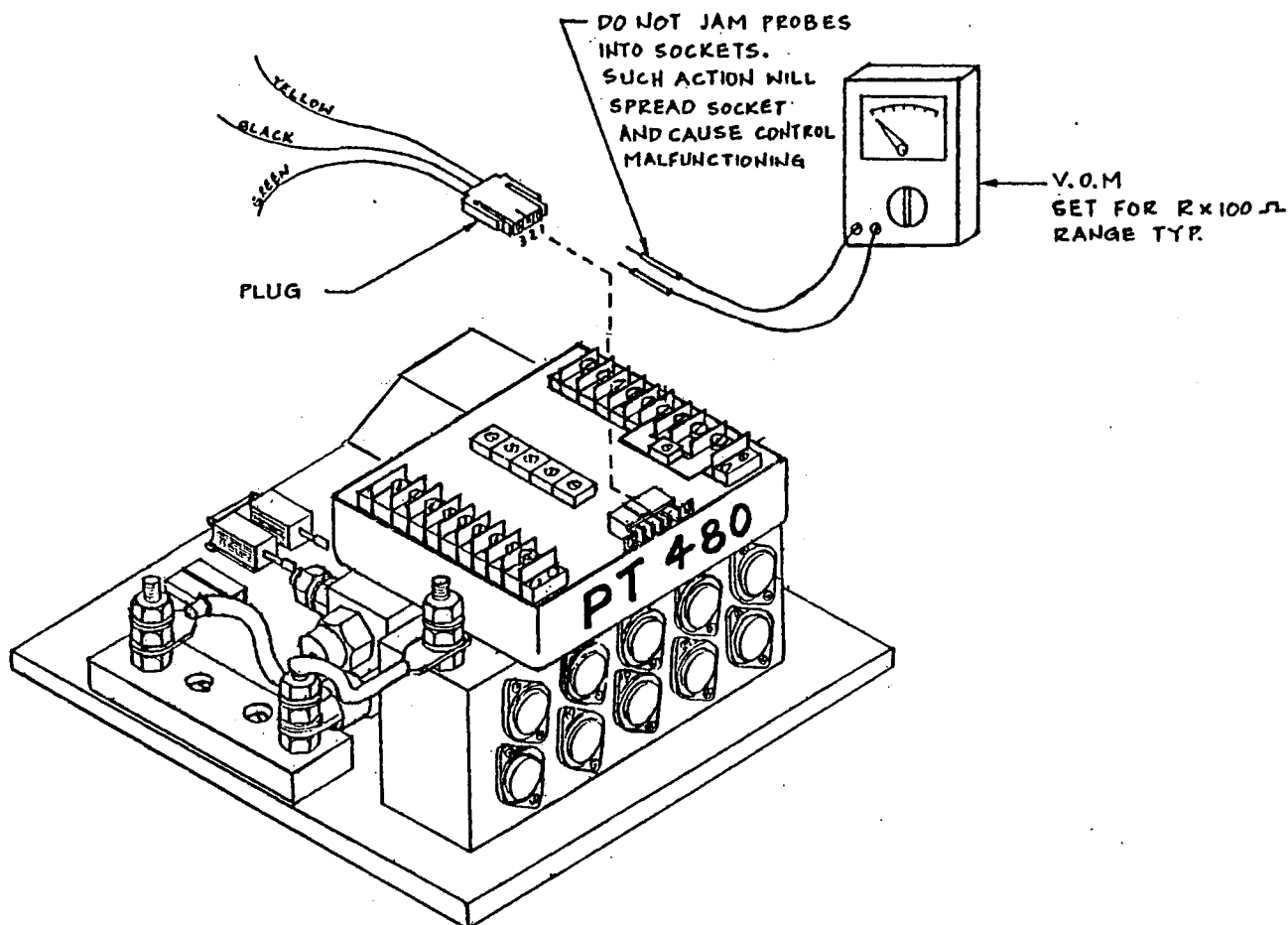

PWR-TRON 480 48 VOLTS

POTENTIOMETER CHECK & ACCELERATOR LINKAGE ADJUSTMENT

1. Disconnect plug (with yellow, black and green wires) at PWR-TRON logic unit.
 2. Read 4K to 5K ohm on V.O.M. between sockets 1 and 2 (yellow and black wires) with accelerator pedal in off position.
 3. With accelerator pedal fully depressed, read 0 - 300 ohm on V.O.M. between sockets 1 and 2 (yellow and black wires). Adjust the accelerator pedal stop and /or accelerator linkage to achieve the above readings.
- * DO NOT rely on return stop inside the accelerator module. It is only a safety feature, not designed for constant foot/pedal return pounding.
4. Reconnect plug to PWR-TRON 480 logic unit.

CONTINUITY AND POWER CHECK

NOTE: VEHICLE DRIVE WHEELS MUST BE JACKED UP OFF FLOOR FOR FOLLOWING TEST.

CAUTION: THIS IS A FACTORY CHECKOUT PROCEDURE AND SHOULD ONLY BE MADE BY A QUALIFIED MECHANIC.

After the PWR-TRON system has been installed, a preliminary power check is required, prior to fine tuning of the PWR-TRON. The vehicle should be ready for basic operation at this time.

Lift green lead at S1 (refer to combined circuit diagram) and place a light (24, 36 or 48V) in series with S1 and field pole on PWR-TRON. Place forward/reverse switch in forward. Initiate accelerator slowly, light should come up to maximum brilliance at full acceleration. Repeat same step for reverse. If problems are encountered, see "Trouble Shooting" section. Also check acceleration rate by quickly depressing accelerator full. Light should come to full brilliance in 3 seconds. (Caution, do not perform plugging with light attached.

When both steps are completed satisfactorily, place vehicle on floor, prepared for operation and fine tuning of the PWR-TRON unit. Proceed to page on "Trimpot Adjustment".

DRIVER TRANSISTOR (AMPLIFIER
FOR TRANSISTOR SET) APPLY
SILICONE SEALANT AROUND EDGE

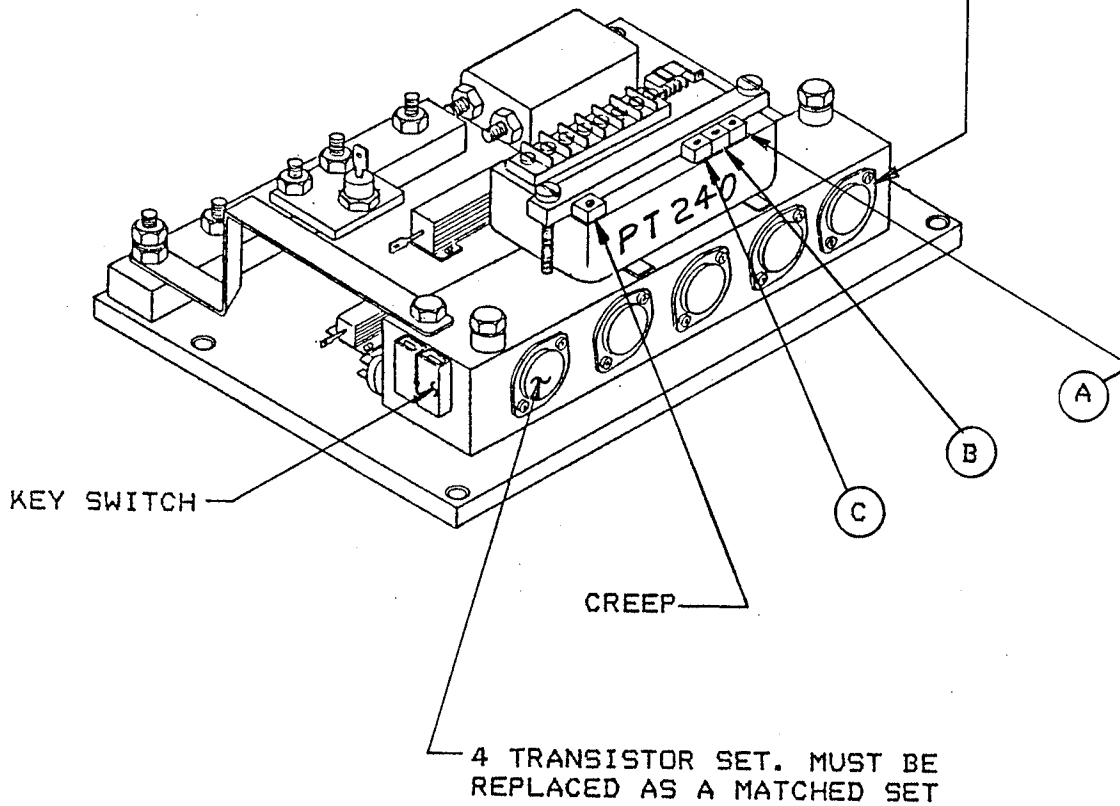

PWR-TRON 240 TRIMPOT ADJUSTMENTS

PERFORM ALL TRIMPOT ADJUSTMENTS IN ORDER SHOWN

- A. ACCELERATOR - Turn full direction of arrow
- B. Plugging - Turn full opposite direction of arrow to start.
Turn up 1/8 in direction of arrow
- C. CURRENT LIMITER - Turn full direction of arrow

CREEP - Adjust trimpot so motor whines but does not turn when accelerator switch is first closed.

AFTER ALL POTS HAVE BEEN FINAL ADJUSTED, COAT POTS
WITH WHITE SILICONE SEALANT.

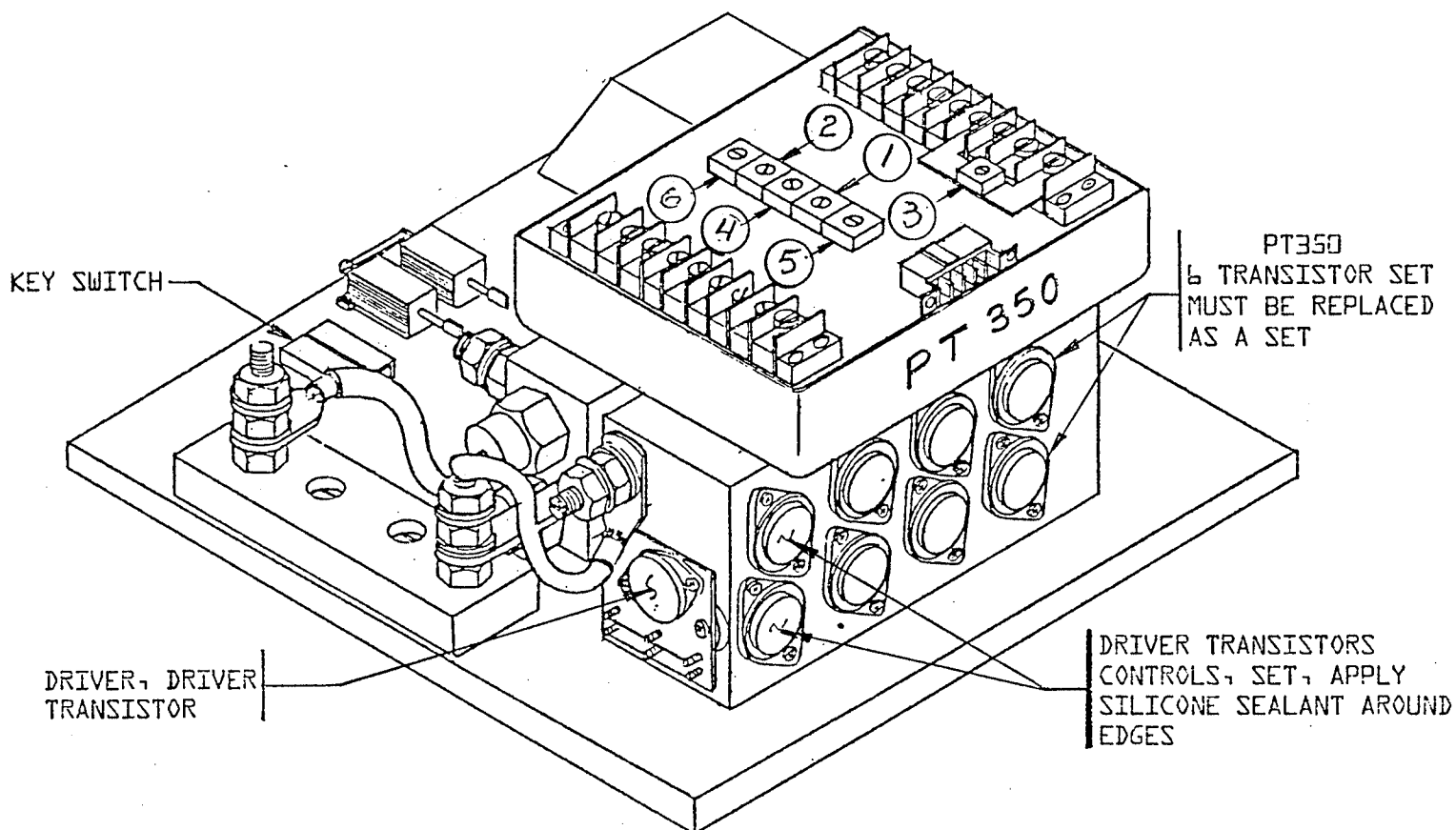

PT 350/480 TRIMPOT ADJUSTMENTS
PT480 IS 48V ONLY

Perform all trimpot adjustments in the order shown. All braking is done last.

1. CURRENT LIMITER - Turn full direction of arrow
2. ACCELERATOR - Turn full direction of arrow
3. MAX BRAKE - Turn full opposite direction of arrow
4. BRAKE - Turn full opposite direction of arrow to start. Turn up 1/8 in direction of arrow
5. VOLTS ADJ. - Adjust trimpot so "solenoid clicks" on and motor whines when accelerator switch is first closed
6. LOW SPEED MAX - Option feature, no adjustment required

AFTER ALL POTS HAVE BEEN ADJUSTED, COAT POTS WITH WHITE SILICONE SEALANT.

TROUBLE SHOOTING
(USE COMBINED CIRCUIT FOR CORRECTIVE ACTION)

<u>SYMPTOM</u>	<u>PROBABLE CAUSE</u>	<u>CORRECTIVE ACTION</u>
1. Vehicle goes forward does not move in reverse	Motor to solenoid wired wrong or bad solenoid	(See combined circuit) B neg from CB may be wired to field on PWR-TRON. Wire to B neg. if required, replace reverse solenoid.
2. Vehicle goes Rev/Fwd instead of Fwd/Rev	Wires reversed at Fwd/Rev switch	Route white wire from Fwd switch to motor. A1 and blue wire from reverse switch to motor, A2
3. Vehicle does not accelerate properly, full on, when checked with light	Solenoid GND connected to field input (green)	(see combined circuit) move to B neg. (same action as item no. 1
4. Catastrophic transistor failure during plugging	Motor/bat. lead to pos. (B+) on control omitted or mis-connected	(see combined circuit) * Replace transistor re-wire B+
5. Vehicle operates then stops. Motor whine present. <u>WARNING: Do not operate. Release accelerator immediately.</u> Continued operation could cause logic damage.	Plugging diode failure; 1. Yellow leads not properly connected. 2. Motor leads over 5' long 3. Incorrect diode	Route yellow leads to field terminal on PWR-TRON unit. Check plugging diode. Replace if necessary
6. Vehicle does not give smooth acceleration when viewed with test light.	Check accelerator module Potentiometer wired in-correctly. (yellow, black green)	Reroute yellow, black, and green wires per combined circuit diagram.
7. Test light indicates acceleration but turns off at full speed.	Cam reversed on accelerator module	Remove accelerator module. Remove accelerator arm/shaft, re-install cam. correctly
8. No output from control	Batteries <u>not</u> connected or improperly connected Key switch input not connected/key-off micro switch not connected (no solenoids on)	First, check key is on. Make certain trim-pot has not been turned too far. (into "overtravel" area)

TROUBLE SHOOTING (CONTINUED)
(USE COMBINED CIRCUIT FOR CORRECTIVE ACTION)

<u>SYMPTOM</u>	<u>PROBABLE CAUSE</u>	<u>CORRECTIVE ACTION</u>
9. No apparent output motor whines.	Grade or load is too great. Motor armature or field short.	See item 1. One direction missing, same action as item no. 1.
10. Vehicles "growls" during acceleration	PWR-TRON B+ to reverse solenoid (red lead) wired wrong.	(See combined circuit) Red lead from B+ tied to outside post. Re-wire red lead to reverse terminal post as on reverse solenoid.
11. Vehicle shudders and shakes	Battery voltage too low	Check batteries re-charge as necessary
12. Vehicle stalls, sits and whines	Bad accelerator pot or due to pulley turning free on pot shaft.	Apply "Super Glue" to pulley. If pot is O.K. and pulley is not loose on shaft, then adjust plugging pot 1/4 turn.
* Transistors must be replaced as matched sets: See respective page for speed controller.		

SUGGESTED SPARE PARTS LIST
PWR-TRON SPEED CONTROLLER SYSTEM

T-D PART NO.	DESCRIPTION	QTY. NO. OF CARTS		
		REQ. 1-20	21-50	50-UP
62-024-00	PT-240 Speed Controller	1	1	2
62-024-21	Flywheel Diode	1	2	4
62-024-23	Plugging Diode	1	2	4
62-024-31	Drive Transistor	1	2	4
62-024-32	Power Transistor	1(set)	2	4
62-024-22	Capacitor	1	1	2
62-024-35	Thermal Switch	1	1	2
62-024-36	Resistor, 70 OHM 10W	1	1	2
62-024-37	Resistor, 1/2 OHM 25W	1	1	2
62-024-10	Cover PT-240	1	2	4
72-501-24	Solenoid SPST 24V	1	1	2
72-501-25	Solenoid SPDT 24V	2	2	4
72-501-36	Solenoid SPST 36V	1	1	2
72-501-37	Solenoid SPDT 36V	2	2	4
79-840-00	Circuit Breaker	1	1	2
61-838-20	Buss, Curved	1	1	2
75-235-11	Jumper, 2 In x 4 Ga. Red.	1	1	2
75-235-20	Jumper, 4-1/4 In X 4 Ga. Red	2	2	4
75-224-10	Jumper, 18 Ga w/diode	1	2	4
72-560-51	Cover, Solenoid Panel	1	2	4
62-030-11	Accel Module (R 3-74)	1	1	2
62-030-12	Accel Module (1248 B)	1	1	2
62-030-13	Accel Module (B 2-10)	1	1	2
62-030-14	Accel Module (R 3-80)	1	1	2
62-030-31	Rotor Accel Module (R 3-74)	1	1	2
62-030-32	Rotor, Accel Module (1248B)	1	1	2
62-030-33	Rotor, Accel Module (B 2-10)	1	1	2
62-030-44	Rotor, Accel Module (R 3-80)	1	1	2
62-030-58	Cover, Accel Module	1	2	4
62-035-00	PT350 Speed Controller	1	1	2
62-035-21	Flywheel Diode	1	2	4
62-035-21	Plugging Diode	1	2	4
62-035-31	Driver Transistors	1	2	4
62-035-32	Power Transistors	1 (set)	2	4
62-035-24	Capacitor	1	1	2
62-035-10	Cover, PT350	1	2	4
62-035-38	Driver, Driver Transistor	1	2	4
62-048-00	PT480 Speed Controller	1	1	2
62-048-31	Driver Transistors	1	2	4
62-048-32	Power Transistors	1	2	4
62-048-36	Resistor 150 OHM 10W	1	1	2
62-048-37	Resistor 1K5 OHM 10W	1	1	2
62-048-38	Driver, Drivr Transistor	1	2	4
72-560-20	Contactator Panel Assembly	1	1	2
71-306-70	Contactator, Fwd. 75A 48V DPST	1	1	2
71-306-71	Contactator, Rev. 75A 48V SPDT	1	1	2
71-306-72	Contactator, Iso. 75A 48V SPST	1	1	2

N O T I C E O F C H A N G E

WE WANT OUR MANUALS TO BE USEFUL AND CORRECT. IF YOU DISCOVER AN ERROR OR WISH TO SUGGEST CHANGES, PLEASE FILL OUT THIS SHEET AND MAIL IT TO TAYLOR-DUNN.

MANUAL NO. _____ SERIAL NO. _____ DATE: _____

* AN ERROR(S) EXISTS ON THE FOLLOWING SECTION(S) AND PAGE(S) NO.

SECTION _____ PAGE NO. _____ LINE OR ITEM _____

* EXAMPLE: Section 13, Page 5, Item 5.
PART NO. 41-350-55 KIT, CYLINDER REPAIR SHOULD BE PART NO. 41-350-66.

MAIL TO: TAYLOR-DUNN
ATTN: ENGINEERING
2114 W. BALL ROAD
ANAHEIM, CA 92804

=====

N O T I C E O F C H A N G E

WE WANT OUR MANUALS TO BE USEFUL AND CORRECT. IF YOU DISCOVER AN ERROR OR WISH TO SUGGEST CHANGES, PLEASE FILL OUT THIS SHEET AND MAIL IT TO TAYLOR-DUNN.

MANUAL NO. _____ SERIAL NO. _____ DATE: _____

* AN ERROR(S) EXISTS ON THE FOLLOWING SECTION(S) AND PAGE(S) NO.

SECTION _____ PAGE NO. _____ LINE OR ITEM _____

* EXAMPLE: Section 13, Page 5, Item 5.
PART NO. 41-350-55 KIT, CYLINDER REPAIR SHOULD BE PART NO. 41-350-66.

MAIL TO: TAYLOR-DUNN
ATTN: ENGINEERING
2114 W. BALL ROAD
ANAHEIM, CA 92804